

**GROUNDWATER HYDRAULICS
OF EXTENSIVE AQUIFERS**

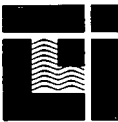

International Institute for Land Reclamation and Improvement
P.O. Box 45 / Wageningen / The Netherlands

GROUNDWATER HYDRAULICS
OF EXTENSIVE AQUIFERS

J. H. EDELMAN

INTERNATIONAL INSTITUTE FOR LAND RECLAMATION AND
IMPROVEMENT ILRI WAGENINGEN THE NETHERLANDS 1972

Bulletin 13

CONTENTS¹⁾

9		INTRODUCTION
12		Notes and list of symbols
15	1	FUNDAMENTALS
15	1.1	<i>The law of linear resistance</i>
15	1.1.1	Formulation of the law
18	1.1.2	Extensive aquifers
22	1.2	<i>The law of continuity</i>
25	1.3	<i>Differential equations and boundary conditions</i>
25	1.3.1	Elementary example
27	1.3.2	General equations
28	1.3.3	Boundary and initial conditions
31	1.3.4	Methods of integration
32	1.3.5	Dimensions
35	2	STEADY FLOW, CONSTANT D , GIVEN n
36	2.1	<i>Superposition</i>
36	2.1.1	The principle
38	2.1.2	Water resources

¹⁾ The meaning of the symbols used in the titles are, D : thickness of the aquifer, n : recharge of the aquifer, φ : potential in the aquifer, φ' : potential defining the water table in the low-permeability top layer, q : rate of flow per unit width over the height D of the aquifer. For further details about the meaning of symbols see 'Notes and list of symbols'.

43	2.2	<i>Parallel flow</i>
43	2.2.1	Two canals
45	2.2.2	Three canals
47	2.3	<i>Flow around wells</i>
47	2.3.1	Infinite aquifer
48	2.3.2	Radius of influence
51	2.3.3	Well near a canal
54	2.3.4	Well between two canals
55	2.3.5	Well between a canal and an impermeable boundary
57	2.3.6	Well near a canal in uniform flow
60	2.3.7	Sloping base
61	2.3.8	Approximation for series of wells
63	2.4	<i>Solutions in terms of complex numbers</i>
64	2.4.1	Fundamentals
68	2.4.2	Well in an infinite aquifer.
69	2.4.3	Well near a canal
73	2.4.4	Well near a canal in a uniform flow
78	3	STEADY FLOW, VARIABLE D , GIVEN n
78	3.1	<i>Analogy with systems with constant D</i>
79	3.2	<i>Superposition and water resources</i>
81	3.3	<i>Parallel flow</i>
83	3.4	<i>Flow around wells</i>
85	3.5	<i>Sloping base</i>
88	4	STEADY FLOW, PARTLY CONFINED AQUIFER, GIVEN ϕ'
88	4.1	<i>Superposition and water resources</i>
89	4.2	<i>Parallel flow</i>
89	4.2.1	One canal
91	4.2.2	Two different phreatic levels
92	4.2.3	ϕ' constant between two canals
93	4.2.4	Arbitrary ϕ' values
95	4.2.5	Arbitrary ϕ' values between two canals
95	4.3	<i>Radial flow</i>
95	4.3.1	Bessel functions
97	4.3.2	Flow in and around a circular area
100	4.3.3	Flow around a well
101	4.3.4	Several wells
102	4.3.5	Canal of limited length

104	5	NON-STEADY FLOW (CONSTANT D)
104	5.1	<i>Fundamentals</i>
104	5.1.1	Elasticity
105	5.1.2	Differential equations and superposition
106	5.1.3	Water resources
106	5.2	<i>Elementary sinusoidal waves (Parallel flow)</i>
107	5.2.1	Scheme A (Phreatic aquifer)
111	5.2.2	Scheme B (Partly confined aquifer, $\varphi' = 0$)
112	5.2.3	Scheme C (Confined aquifer)
113	5.2.4	Scheme D (Partly confined aquifer with varying φ')
116	5.2.5	Reduction of Scheme D to Scheme A
117	5.2.6	Reduction of Scheme D to Scheme B
118	5.2.7	Reduction of Scheme D to Scheme C
119	5.3	<i>Superposed sinusoidal waves (parallel flow)</i>
120	5.3.1	Constant φ as a boundary condition
121	5.3.2	$q = 0$ as a boundary condition
122	5.3.3	Periodic variations in recharge
125	5.4	<i>Sudden change in boundary condition. Parallel flow</i>
125	5.4.1	Basic formulas
130	5.4.2	Superposed variations
134	5.5	<i>Sudden change in boundary condition. Radial flow</i>
138	6	TWO FLUID SYSTEMS OF FRESH AND SALT WATER
138	6.1	<i>Fundamentals</i>
138	6.1.1	Introduction
140	6.1.2	Water resources
140	6.1.3	The law of discontinuity at the interface
144	6.2	<i>Steady flow</i>
144	6.2.1	Differential equations
146	6.2.2	Boundary conditions
147	6.2.3	Basic laws for salt water at rest
151	6.2.4	Parallel flow. Salt water at rest
153	6.2.5	Extraction from canals
157	6.2.6	A well near the coast
158	6.2.7	Partly confined aquifer
163	6.2.8	Flowing salt water
167	6.3	<i>Non-steady flow</i>
167	6.3.1	Differential equations and boundary conditions
169	6.3.2	Superposition

173	6.3.3	Partly confined aquifers
176	6.3.4	Propagation of the tide
177	6.3.5	Periodic variations in recharge rate
182	6.3.6	Extraction of fresh water from a well or gallery
187	6.4	<i>Transition layer</i>
187	6.4.1	Fundamentals
189	6.4.2	Extraction of fresh water from a well or gallery
192	6.4.3	Double pumping
193	6.4.4	Testing saline boreholes
196	7	NUMERICAL METHODS
197	7.1	<i>Iteration methods</i>
197	7.1.1	Elementary example
199	7.1.2	Different nets
200	7.1.3	Various difference equations
204	7.1.4	Improved procedures
206	7.1.5	Wells in the field
208	7.2	<i>Numerical methods without iteration</i>
208	7.2.1	Steady flow in a partly confined aquifer (one fluid)
209	7.2.2	Non-steady flow
216		BIBLIOGRAPHY

INTRODUCTION

The term extensive aquifers is used to denote aquifers whose horizontal dimensions are much larger than their thicknesses, so that the losses of head due to the vertical velocity components may be neglected. The term groundwater hydraulics is used in the sense of deductive theory.

A series of strongly schematized problems is analysed with a view to applying the results in groundwater engineering. The publication is a text-book, not a manual, stress being laid on didactics, not on completeness or detail. The mathematical derivations are given in full, starting from the fundamental physical laws; mathematical methods, however, are not explained. As a rule, a problem is discussed in four stages: posing the problem, formulating the solution, deriving the formulae and analysing the result. The mathematical derivations are marked by a disjoined vertical line; they should be omitted at first reading, when the reader's attention should remain concentrated on the main issue of the theory.

The basic laws and assumptions adopted are more or less consecrated by tradition. They have, however, a limited range of validity. This range has been established for some laws (e.g. the law of linear resistance). In other instances it forms the subject of modern investigations (e.g. the law relating the stored or released quantities of water to the rise or fall of the water table, where the notion of effective porosity is only an approximation). This physical side of the problem is not treated. It is thought too important to be discussed in complementary remarks to an essentially deductive study. If it were to be treated comprehensively, it should be made the subject of a separate study.

The use to be made of the solutions of schematized problems may be summarized in the following points:

1. Since flow of groundwater is hidden to the eye, we have no everyday experience with it, as we have with mechanical phenomena; the best way to get acquainted with the nature of the phenomena is to solve, as an exercise, a series of elementary problems. We are also blind to the magnitude of quantities involved in problems of groundwater flow; to estimate them properly we need orientating calculations on strongly schematized models.

2. Physical formulas have a limited range of validity. When, for example, a phenomenon depends on three factors, A, B, and C, it depends on A alone when A is predominant, on A and B when C is negligible. Posing the problem requires an appreciation of the relative magnitude of the relevant quantities. This is another reason for starting with orientating calculations.

3. Engineering calculations generally cover two phases. First the hydraulic characteristics of the aquifer are determined on the basis of observations and tests; then the dimensions and flow rates of the design are determined on the basis of these characteristics. In both phases it is recommended that rough, orientating calculations be used to start with, and that they be repeated once or several times on a more refined basis. The reality should be compared with standard flow systems, preferably chosen so as to comprise the reality between conditions that are too favourable and too unfavourable. This is the principle usually adopted for the calculation of steel and concrete constructions.

4. Groundwater calculations are generally rough, because the underground is irregular, because tests are costly, and because some basic quantities, such as evaporation, are only approximately known. This stresses the importance of elementary calculations above refined ones. The use of computers is justified only when the observations and tests have been adequate to obtain precise results, and this precision is needed for the design. Another use of computers is to solve standard problems that are too difficult for mathematical analysis.

5. The basic laws of groundwater hydraulics are linear. Thus, in problems depending on several factors, the influence of each factor may be calculated apart, and the results added. This principle, that of superposition, will be the guideline throughout the theory. It makes understanding easy, and allows complicated calculations to be split up into elementary ones.

Part of the theory has been acquired from literature; part is the result of my own studies. Foreign elements have not been presented in the form chosen by the authors. All elements have been merged into greater units of thought, in which process they have lost their individuality. Each chapter forms a unit; the chapters form a sequence: the publication should be read as a whole.

Since foreign elements have not been given in their original form, and all derivations

are given in full, no reference is made to the original publications. A list of comprehensive modern books is added, to be used for further study as well as for detailed reference. However, the names of G. J. de Glee, J. P. Mazure, J. van Oldenborgh, and J. H. Steggewentz should be mentioned, since their work has been fundamental for the present studies.

Thanks are due to G. de Josselin de Jong, and A. Verruijt for critical remarks, as well as to N. A. de Ridder for his critical reading of the manuscript and to Mrs. M. F. L. Wiersma-Roche for linguistic corrections.

Wageningen, October 1968

J. H. E.

NOTES AND LIST OF SYMBOLS

1. A disjoined vertical line marks the derivations.
2. The text always refers to the figure indicated at the beginning of the paragraph.
3. The following conventions are used in the figures
shaded: impermeable
dotted: low permeability
blank: permeable
4. Throughout this study the potential is defined as a pressure, while most engineers are accustomed to defining it as a height (length dimension). As long as one-fluid is concerned, they may read the formulas in their own interpretation, considering the potential ϕ as a height, the permeability k as a velocity, and reading for μ the effective pore space, a dimensionless quantity. In the theory of two-fluid systems, however, all symbols must be read according to the definitions of this study.
5. All formulas are dimensionless. They apply to any consistent system of units (founded on one unit for the mass, one unit for the length, and one unit for the time).
6. Where references are made to other parts of the text, the main units, 1 to 7, are called chapters; the smaller units, indicated by one or two decimal figures are called sections.
7. Most symbols are used throughout the text, often without explanation. Their meaning and dimension are listed below, and reference is made to the section in which they are introduced. As a rule the following distinctions are made:
Without prime: related to the fresh water in the aquifer.
With prime: related to the low-permeability top layer.
With double prime: related to the salt water in the aquifer.

Aquifer in one-fluid problems

- RL* Reference level.
- x* and *y* Horizontal coordinates.
- z* Vertical coordinate.
- t* Time.
- T* Period of periodic movements.
- ω* Equal to $\frac{2\pi}{T}$, used in $\sin \omega t$, defining sinusoidal variations. [t^{-1}]
(Section 5.2).
- φ* Potential, defined as a pressure. [$ml^{-1}t^{-2}$] (Section 1.1.1).
- γ* Specific weight of water. [$ml^{-2}t^{-2}$]
- h* Piezometric height. [l] (Section 1.1.1).
- k* Permeability, generally in a horizontal direction. [$m^{-1}l^3t$] (Section 1.1.1).
- D* Thickness of the water body contained in the aquifer. Either constant or variable. [l].
- kD* Transmissivity of the aquifer for horizontal flow. [$m^{-1}l^4t$] (Section 1.1.2).
- m* Effective porosity. Volume of water released from or taken into storage per unit area of the aquifer due to variation of the phreatic level by unit height. Dimensionless. (Sections 1.2 and 6.3.1).
- μ* Volume of water released from or taken into storage per unit area of the aquifer, due to a change of the water level corresponding to unit potential.
 $\mu = \frac{m}{\gamma}$. [$m^{-1}l^2t^2$] (Section 1.2).
- v* Velocity in the sense of the quantity of water passing per unit time through a unit area including the section over the grains. [lt^{-1}] (Section 1.1.1).
- q* Quantity of flow through unit width of an aquifer with thickness *D*.
 $q = vD$. [l^2t^{-1}] (Section 1.1.2).
- Q* Quantity of flow through an arbitrary cross-section, e.g. the flow towards a well. [l^3t^{-1}] (Section 1.1.2).
- n* Recharge of the aquifer from the upper, nonsaturated soil layers, as a recharge of water per unit time and per unit area of the aquifer. [lt^{-1}] (Section 1.2).
- N* Mathematical concept, introduced to make a general formulation of the law of continuity possible: the volume of water joining the groundwater flow in the aquifer per unit time per unit area of the aquifer, as a consequence of both recharge and fall of the piezometric level. [lt^{-1}] (Section 1.2).

Low-permeability top layer

ϕ'	Potential (Section 1.1.2).
h'	Piezometric height (function of z) (Section 1.1.2).
k'	Permeability in vertical direction (Section 1.1.2).
D'	Thickness of the water layer contained in the top layer, always considered constant over the area of the aquifer (Section 1.1.2).
k'/D'	Transmissivity of the top layer for vertical flow.
m'	Equivalent of m for the top layer (Section 1.2).
μ'	Equivalent of μ for the top layer (Section 1.2).

Aquifer in two-fluid systems

RL	Reference level.
SL	Sea level.
γ and γ''	Specific weight of fresh and salt water respectively. (Section 6.1.1).
ϕ and ϕ''	Potentials of fresh and salt water respectively (Section 6.1.3).
h and h''	Piezometric height of fresh and salt water respectively (The piezometer tube filled with fresh and salt water respectively) (Section 6.1.3).
D and D''	Thickness of fresh and salt water body respectively (Section 6.2.1).
D_t	Sum of D and D''
Z	Elevation of the interface above reference level (negative when reference level coincides with sea level) (Section 6.1.3).
m	Effective porosity. Volume of water released from or taken into storage per unit area of the aquifer, due to variation by unit height of the phreatic surface or the interface. Dimensionless. (Sections 1.2 and 6.3.1).
μ	Same as for one-fluid system. Related to ϕ . For the water surface only; not for the interface.
v and v''	Horizontal velocities, or velocities parallel to the interface in fresh and salt water (volume of water displaced per unit time per unit section, including the section over the grains) (Section 6.1.3).
q and q''	Quantities of flow per unit width over the thickness of the fresh and salt water body respectively. $q = vD$; $q'' = v''D''$ (Section 6.2.1).
Q and Q''	Quantities of flow through an arbitrary section in fresh and salt water respectively. [l^3t^{-1}].

1. FUNDAMENTALS

1.1. THE LAW OF LINEAR RESISTANCE

1.1.1. Formulation of the law

Water flowing through a porous medium loses energy. The quantity of energy per unit volume of water is called the potential ϕ , for reasons to be specified below. Its dimension $[ml^{-1}t^{-2}]$ is that of a pressure.

There is no uniformity in the definition of the potential. In engineering practice it is more common to define ϕ as the quantity of energy per unit weight of the water. The potential thus defined has the dimension of a length, and can be shown graphically as an elevation above a plane of reference. This definition, however, cannot be admitted in the following studies, as it would complicate the formulas of two-fluid problems. For fresh water problems all formulas describing the flow systems are identical in both practices, but with a different meaning of the symbols.

Figure 1. – The potential ϕ at a certain point P of the aquifer is given by

$$\phi = p + \gamma z$$

where p is the pressure and γ the specific weight of the water at P ; z is the elevation of P above reference level RL . This expression is taken from the theory of general hydraulics: it will not be derived here. In its general form it contains still a third term $(\rho v^2)/2$, depending on the velocity of the water, where ρ is the density and v the velocity of the water at P . This term can be ignored in groundwater hydraulics, where velocities are always low.

A piezometer is a simple tube, placed in the ground and screened over a certain

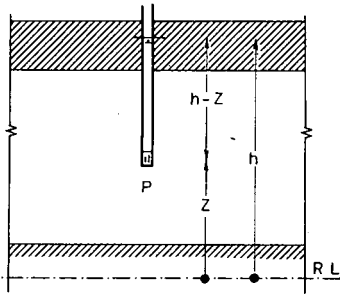

Fig. 1

length at its bottom end. For theoretical considerations the screen may conveniently be reduced to a point. The piezometric height h at this point is the elevation of the water level in the tube above the reference level RL . The potential φ is related to the piezometric height h by

$$\varphi = \gamma h$$

The pressure at P corresponds to the water column $h - z$ inside the tube; hence $p = \gamma(h - z)$. Substitution of this value for p in the expression $\varphi = p + \gamma z$ gives $\varphi = \gamma h$.

The discharge Q is the quantity of water flowing per unit time through a small section S perpendicular to the flow. It is customary to take for S the rough area over both pores and grains. The quantity $v = Q/S$, therefore, does not correspond to the average velocity of the water particles. Yet it is customary to call v the velocity of the water.

Throughout the study laminar flow will be assumed. In nature this condition is usually satisfied. Exceptions may exist locally where the velocities are particularly high, such as near pumped wells or where fresh groundwater flows into the sea. In laminar flow the losses of energy are proportional to the velocities. This law of linear resistance is known as Darcy's law, when applied to groundwater. It may be written as:

$$v_x = -k \frac{\partial \varphi}{\partial x}, \quad v_y = -k \frac{\partial \varphi}{\partial y}, \quad v_z = -k \frac{\partial \varphi}{\partial z}$$

where k is a constant, and v_x , v_y , and v_z are the components of the velocity in the directions of the coordinate axes x , y and z . For an arbitrary direction s

$$v_s = -k \frac{\partial \varphi}{\partial s}$$

which will not be proved here.

Formulas of this type are well known in physics. Any quantity φ satisfying them is

called a potential. If it defines a velocity, as in the present case, it is called a velocity potential; if a force, a force potential, etc. Consequently the theory of groundwater flow appears as a particular case of potential theory.

The constant k , as defined by these formulas, has the dimension $[m^{-1}tl^3]$. In current engineering practice, where the potential ϕ is defined as a length, and k is determined by the same formulas, k takes the dimension of a velocity. If values of k are given as velocities, they must be divided by the specific weight of the water, to obtain the corresponding values in the practice to be followed here.

The permeability k depends on the characteristics of the soil, and the viscosity η of the water. Strictly speaking, it is improper to call it the permeability of the soil, as it depends also on the properties of the water. Other names have been proposed, but since there is no uniformity on this point, simply the most current term, although improper, will be used.

As can be shown from the theory of Dimensional Analysis or from more thorough theoretical considerations, the following relationship exists:

$$k = k_0 \frac{d^2}{\eta}$$

This formula should be read with the idea of similitude in mind. If two ideal scale models are imagined, composed of grains of the same form and arrangement, but of different size, the geometrical scale of either model may be determined by any length dimension d of the grains, e.g. the average grain size, defined in any conventional way. The models may be filled with fluids of different viscosity η . The formula then indicates the relationship between k , d and η in each model. The coefficient k_0 is a dimensionless constant, depending on the form of the grains and the definition of d , and is the same in both models. It can be seen from this relationship that k is equal for both salt and fresh water filling the same medium, if the difference in viscosity between the fluids is neglected.

In the following studies homogeneous soil and water will be assumed. Where in Chapters 6 and 7 two-fluid systems are described, the property of homogeneity will apply to each of the fluids separately. Strictly speaking, granular material is not homogeneous. The term will be used with respect to the average values of the soil characteristics (pore space, permeability, etc.) in units of volume, large compared with the dimensions of the grains, and small compared with those of the aquifer. Used in this sense, the word homogeneity expresses that these average values of the soil characteristics are the same throughout the aquifer. As a consequence, the hydraulic quantities (pressure, velocity, etc.) are continuous functions of the coördinates. In nature the condition of homogeneity is in general not fully satisfied. The main exceptions are:

Fig. 2

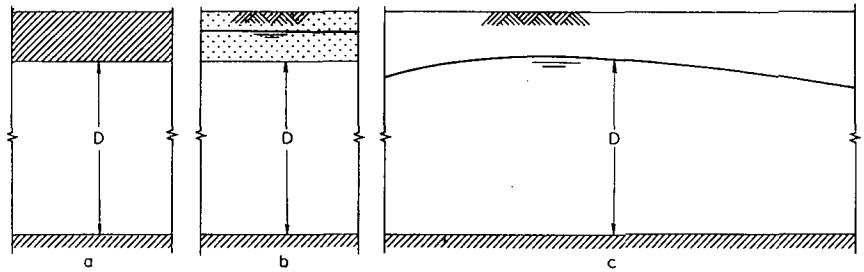

- Sandy aquifers are usually made up of alternating layers of sediments having different properties. They may contain layers of fine material, or even lenses of silt or clay, which impede the vertical water movement. Natural aquifers usually have a greater permeability in horizontal than in vertical direction.
- Limestone, if finely fissured, has the characteristics of a permeable medium, but its degree of fissuring is seldom uniform throughout the aquifer.
- The density and viscosity of water vary with temperature. In thick aquifers the increase in temperature with depth plays a role.
- The viscosities of fresh and salt water are slightly different. This factor will be ignored in Chapters 6 and 7.

1.1.2. Extensive aquifers

The following studies will deal alternately with three types of aquifers: confined, partly confined, and phreatic, to be described below. As a general assumption they rest on a horizontal, impermeable base. Some special cases will be considered where the aquifer dips slightly.

Figure 2a represents a confined aquifer, covered with a horizontal impermeable layer, and saturated with water under pressure. The thickness D of the water layer is constant and equal to that of the aquifer.

Figure 2b represents a partly confined aquifer, i.e. covered by a layer of low-permeability, and saturated with water under pressure, the phreatic level being in the top layer. The term low-permeability will be used in the sense of low compared with the permeability of the aquifer, but not zero. Since the horizontal flow in the top layer will be neglected, as will be explained below, the lateral water movement depends on the thickness D of the aquifer, which is a constant, as in the previous case.

In Figure 2c the groundwater has a free surface. For the sake of simplicity no capillary fringe is considered. Groundwater having a free surface is called phreatic water; the surface, the phreatic surface. The thickness D of the water body is variable from one point to another. For exact calculations the variations of D are considered. For approximate calculations the variations in water height are neglected in comparison

Fig. 3

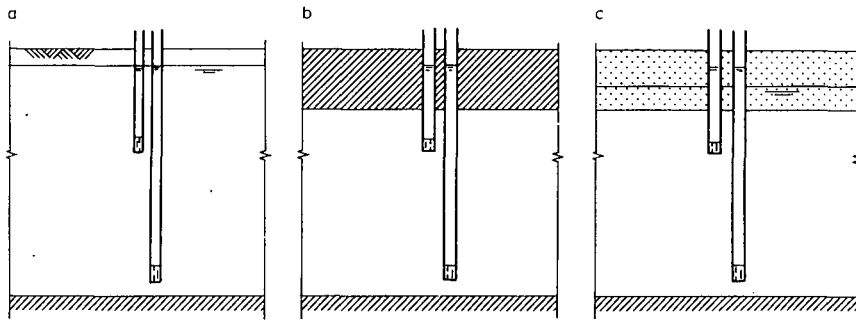

with the total thickness of the water-layer. The variable thickness is then replaced by its average value D . This assumption is frequently made in engineering practice.

In all cases the thickness of the aquifer is assumed to be small compared with its horizontal dimensions. This property is indicated by the term extensive aquifers. The water transport through such aquifers is mainly horizontal. The horizontal velocity components are generally greater than the vertical components and since, moreover, the water moves horizontally over much greater distances than it does vertically, the losses of energy in a horizontal direction are much greater than in a vertical direction, so that as a basic assumption for all following studies, the vertical energy losses are neglected. This assumption may be considered either as an approximation, applicable to an aquifer composed of isotropic material, or as an exact characteristic of an aquifer composed of anisotropic material, having a permeability k in all horizontal directions and an infinitely great permeability in vertical direction.

Figure 3. – When the vertical losses of energy are neglected, the potential φ is a constant in a vertical. Mathematically φ is a function of x and y only, and not of the vertical coördinate z . The same is true for the piezometric head h , which differs from φ only by a factor γ . Hence the water rises to the same level in two piezometers placed in the same vertical at different depths. This is shown for a phreatic, a confined and a partly confined aquifer respectively. In phreatic water the piezometric level corresponds to the water table. In a confined aquifer it rises above the top of the aquifer. The same holds good for a partly confined aquifer, where the piezometric level is generally different from the water level in the top layer.

Figure 4. – The left-hand side shows an aquifer bounded by a river or a lake. It follows from the above that the potential φ is equal at all points to the right of A , regardless of whether these points are chosen in the lake or in the aquifer underneath. In all models, therefore, canals, lakes or the sea will be assumed to be in contact with the aquifer along a vertical plane down to the impermeable bottom, as indicated on

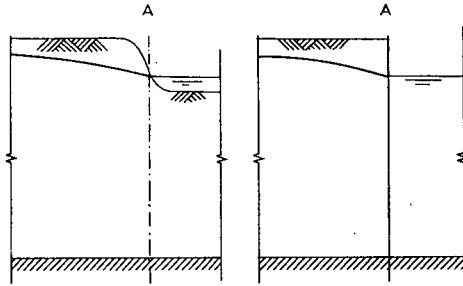

Fig. 4

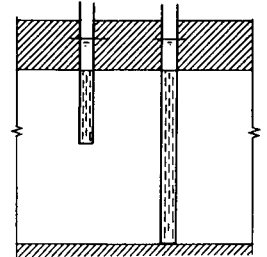

Fig. 5

the right-hand side of the figure. The mathematical expression for the boundary condition is a given value of φ in the vertical plane passing through A.

Figure 5. - Similar considerations can be applied to wells. On the left-hand side a partially penetrating well is shown. Since losses of head inside the wells will be neglected in all studies, mathematically the well face is a boundary of the aquifer, characterized by a constant value of φ . But since vertical losses of energy in the aquifer are neglected as well, the cylindrical part of the aquifer below the bottom of the well has the same characteristic. Therefore, only completely penetrating wells will be considered, as shown on the right-hand side of the figure.

If φ is independent of z , it follows that the same is true for $\partial\varphi/\partial x$ and $\partial\varphi/\partial y$, hence for v_x and v_y . In other words, the water flows at the same rate at all levels. Summation of the discharge over the height of the aquifer is then easy. The symbol q will be used to denote the quantities flowing per unit width over the entire thickness of the aquifer. The notations q_x , q_y and q_s apply to the discharges in the direction of the x and y axes, or in an arbitrary direction s . It follows from the law of linear resistance that

$$q_x = -kD \frac{\partial\varphi}{\partial x}; \quad q_y = -kD \frac{\partial\varphi}{\partial y}$$

which formulas will be taken as a starting point in the following chapters. The product kD is called the transmissivity of the aquifer for horizontal groundwater flow.

The symbol Q will be used to denote the rate of flow through an arbitrary cross-section. In case of radial flow for example, it denotes the flow through a cylinder with radius r and a height equal to the thickness of the aquifer. The quantity Q is then related to q by the elementary relationship $Q = 2\pi r q$, hence

$$Q = -2\pi r k D \frac{\partial\varphi}{\partial x}$$

It should be noted that neglecting the losses of energy due to the vertical components of the velocity does not imply that these components would not exist in the schemes to be examined. Water supplied by infiltrating rain, and reaching the top of the aquifer, is distributed over at least a part of the thickness of the aquifer by vertical velocity components. Or, to give another example, the interface between fresh and salt groundwater may, in case of nonsteady flow, move upwards or downwards, and these displacements can even be calculated when the vertical energy losses are neglected.

In the case of a partly confined aquifer, the flow through the top layer of low permeability has to be considered. The physical quantities of this layer will be indicated with primes to distinguish them from the corresponding quantities of the aquifer. It will be assumed that the thickness D' of the waterbody in the top layer is less than the thickness D of the aquifer; moreover, that the permeability k' is low compared with the permeability k of the aquifer, though not zero. It follows then that the horizontal flow through the top layer can be neglected in comparison with that through the aquifer, because it depends on the product $k'D'$, which is small compared with the product kD .

This assumption can be considered either as an approximation when the top layer is composed of isotropic material, or as an exact formulation when it consists of anisotropic material with a permeability k' in the vertical direction and zero permeability in all horizontal directions. Consequently, if a canal, a lake, or the sea borders the top layer, it will be assumed that no lateral exchange of water takes place, although the potential of groundwater and free water on either side of the boundary might be different.

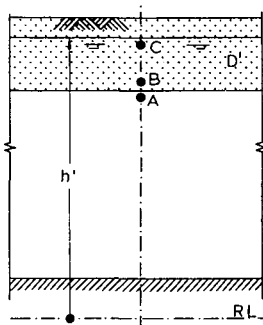

Fig. 6

Figure 6. – Since no horizontal flow is considered here, the rate of vertical flow per unit area, N , is equal at all points of a vertical. It follows from the law of linear resistance that the gradient $\partial\phi'/\partial z$ is a constant, which means that ϕ' varies as a linear

function of the depth. Its value at B , the lowest point of the top layer, is equal to φ at A , which is the potential of the aquifer. This is because the potential depends on p , γ and z where p and q are continuous functions of z at the boundary between top layer and aquifer. For φ'_B may thus be written φ . As to φ'_C , C being the point immediately below the water table, it will be written simply as φ' ; it is related to the height h' of the water table by

$$\varphi' = \gamma h'$$

Thus the gradient on the vertical is $(\varphi' - \varphi)/D'$, and the flow N (positive in a downward direction) is given by

$$N = \frac{k'}{D'}(\varphi' - \varphi)$$

Since the water table is not level, the height of the water column varies. As a general assumption, however, these differences will be neglected, taking for the variable height the average, constant value D' . In the expression for N , D' occurs in the combination k'/D' , called the transmissivity of the top layer for vertical flow, in analogy with the product kD , the transmissivity of the aquifer for horizontal flow.

1.2 THE LAW OF CONTINUITY

In addition to the law of linear resistance a second relation governs the flow of groundwater: the law of continuity. It relates the quantities of the horizontal flow in the aquifer to the quantities flowing in from above. The volume of water received per unit time and per unit horizontal area will be called N . This quantity was introduced in the previous section in the case of partly confined aquifers, where it had a physical meaning. In the case of phreatic aquifers it is a purely mathematical concept, useful in that it enables the law of continuity to be written in a uniform way in all cases. In a general problem, N is the sum of two terms.

The first term, n , denotes the net deep percolation of rain or irrigation water. Part of the rain or irrigation water is lost by evaporation from the surface; a further quantity is taken up by the roots of plants; in dry soils a certain quantity is retained by the soils to make up for the moisture deficit; the rest percolates, and joins the water of the aquifer. The latter quantity, expressed as a volume per unit time per unit area, will be called n , the recharge of the aquifer.

The second term, $-\mu\partial\varphi/\partial t$, is related to the movement of the free water table in the case of nonsteady flow. When the water table moves downwards or upwards, water is released from, or taken into storage respectively. If over an area S the level falls by Δh , a volume of water $\Delta V = mS\Delta h$ is released, m being the effective pore space of the soil. It will be assumed that the values of m for upward and downward movement

are equal, and that the yield is instantaneous. This is the classical, simple assumption. The difficult problem of the relationship between water level variation and yield will not be studied here. Instead of relating ΔV to Δh , it is more convenient to relate it to $\Delta\phi$, according to $\Delta V = \mu S \Delta\phi$, where $\mu = m/\gamma$, with the dimension $[m^{-1}l^2t^2]$. Thus a quantity $-\mu(\partial\phi/\partial t)$ exists, and should be added to n , representing the volume of water released per unit time per unit area.

Hence

$$N = n - \mu \frac{\partial\phi}{\partial t}$$

where N indicates the volume of water joining the horizontal flow per unit time per unit area, due to both infiltration and movement of the water table. A third term might be added to the formula in problems of nonsteady flow, accounting for the quantities of water released or stored, because of the elasticity of ground and water. The influence of the elasticity, however, will not be studied, as will be explained in Chapter 5.

The expression for N will be examined in the three cases of confined, phreatic and partly confined aquifers.

- Confined aquifer. - The impermeable cover of the aquifer allows neither recharge from infiltration, nor the formation of a free water table. Therefore both terms in the expression for N are zero, and

$$N = 0$$

- Phreatic aquifer. - Both terms in the expression for N may exist. Thus in the most general case, that of nonsteady flow,

$$N = n - \mu \frac{\partial\phi}{\partial t}$$

If the flow is steady $\partial\phi/\partial t = 0$, and

$$N = n$$

- Partly confined aquifer. - The same formula

$$N = n - \mu' \frac{\partial\phi'}{\partial t}$$

applies, where μ' is now defined by $\Delta V = \mu' S \Delta\phi'$ and ϕ' is the potential of a water particle just below the water table. Since both the water received from infiltration and that released by the falling water table flow down through the top layer before reaching the aquifer, the following condition applies

$$N = \frac{k'}{D'}(\varphi' - \varphi)$$

In combination

$$N = n - \mu' \frac{\partial \varphi'}{\partial t} = \frac{k'}{D'}(\varphi' - \varphi)$$

This formula, in its general form, applies to nonsteady flow. In problems of steady flow $\partial \varphi' / \partial t = 0$, and thus

$$N = n = \frac{k'}{D'}(\varphi' - \varphi)$$

Once the quantity N is defined, the law of continuity can be formulated in a uniform way for confined, partly confined and phreatic aquifers. Three cases will be examined:

- Parallel flow

$$\frac{\partial q}{\partial x} = N$$

which equation expresses that N corresponds to the increase of q per unit length.

- Radial flow

$$\frac{\partial Q}{\partial r} = 2\pi r N$$

This equation expresses that the increase of Q between two cylinders with radii r and $r + dr$ corresponds to the water received at the rate N on the area $2\pi r dr$ between the two cylinders.

- In a general flow pattern the law of continuity reads

$$\frac{\partial q_x}{\partial x} + \frac{\partial q_y}{\partial y} = N$$

Figure 7 represents an elementary prism in horizontal projection. The quantity of flow entering through the left side is $q_x dy$, that leaving through the right-hand side

$(q_x + \frac{\partial q_x}{\partial x} dx) dy$. The difference is $\frac{\partial q_x}{\partial x} dx dy$. The difference in flow through the

other two sides is $\frac{\partial q_y}{\partial y} dx dy$. The sum of these differences equals the flow $N dx dy$

received on the square.

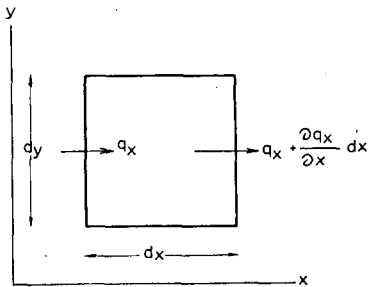

Fig. 7

1.3 DIFFERENTIAL EQUATIONS AND BOUNDARY CONDITIONS

A flow system depends on two basic laws: that of linear resistance and that of continuity. Mathematically, these laws appear as partial or ordinary differential equations, relating ϕ , q_x and q_y to x and y in the case of steady flow, and to x , y and t in the case of nonsteady flow. With steady flow their solution requires boundary conditions; with nonsteady flow boundary and initial conditions. Physically, the differential equations are the formulation of general laws governing large classes of flow systems, while the boundary or initial conditions define each flow system separately. This will be explained first for an elementary system, and then for more general examples.

1.3.1 Elementary example

Figure 8 corresponds to parallel flow with constant n in an aquifer with constant D . It shows a variety of boundary conditions. At A and E the aquifer is bounded by impermeable sides, imposing the condition $q = 0$. In the canals B and C the water levels are given, determining the values of ϕ_B and ϕ_C . From canal D water is extracted at a constant rate q_0 . With these conditions the flow system is defined in each of the sections AB, BC, CD, and DE, as will now be shown.

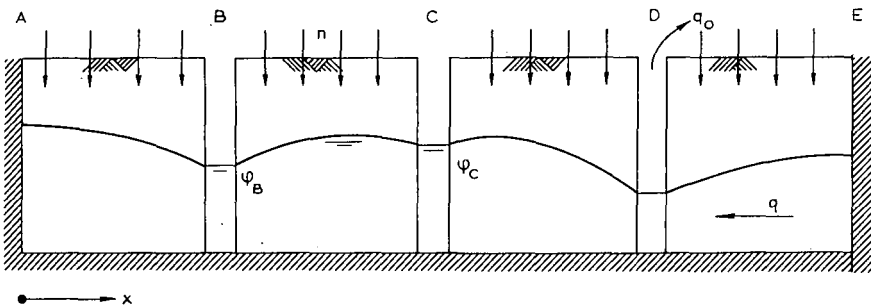

Fig. 8

In each section the law of linear resistance reads

$$(1) \quad q = + kD \frac{d\phi}{dx}$$

and the law of continuity

$$(2) \quad \frac{dq}{dx} = - n$$

The positive direction for x and q , as indicated in Figure 8, are arbitrarily chosen; the plus and minus signs in the differential equations are determined accordingly from the following considerations, looking at the section DE.

- In Equation (1) q is positive, whilst ϕ increases with increasing x ($d\phi/dx$ positive).
- In Equation (2) the recharge n (positive number) results in increasing q with decreasing x (dq/dx negative).

From (1) and (2) q can be eliminated by differentiating (1), and substituting the obtained value of dq/dx in (2).

$$(3) \quad \frac{d^2\phi}{dx^2} = - \frac{n}{kD}$$

This equation gives in differential form ϕ as a function of x , just as (2) gives q as a function of x , also in differential form. Each of these equations is independent of any boundary condition. Thus they express general flow properties of any steady parallel flow system with constant recharge n in an aquifer with constant D . They apply as such to any of the sections AB, BC, CD and DE. The difference between the formulas of these sections is brought about solely by the different boundary conditions.

Twice integrating equation (3) yields successively

$$(4) \quad \frac{d\phi}{dx} = - \frac{n}{kD} x + c_1$$

and

$$(5) \quad \phi = - \frac{n}{kD} \frac{x^2}{2} + c_1 x + c_2$$

where c_1 and c_2 are integration constants. The last equation gives ϕ as a function of x . A similar expression for q can be derived from (4) and (1):

$$(6) \quad q = - nx + c_1 kD$$

Since the differential Equation (3) is of the second order, there are two integration constants, c_1 and c_2 , to be determined. Accordingly two boundary conditions are required. If the condition is of the form

for $x = x_1$, $\varphi = \varphi_1$

substitution in (5) gives

$$(7) \quad \varphi_1 = -\frac{n}{kD} \frac{x_1^2}{2} + c_1 x_1 + c_2;$$

if of the form

for $x = x_2$, $q = q_2$

substitution in (6) gives

$$(8) \quad q_2 = -n x_2 + c_1 k D$$

Thus in section AB, c_1 and c_2 are determined by one equation of the form (7) and one of the form (8); in section BC by two equations of the form (7). Sections CD and DE are linked together. The formulas of either section should be written separately. They contain the integration constants c_1 and c_2 for CD; c_3 and c_4 for DE. These quantities are determined by four conditions, written schematically

In C: $\varphi = \varphi_c$

In D: the values of φ at either side of the canal are equal.

In D: the difference between the values of q at both sides of the canal is equal to q_0 .

In E: $q = 0$.

1.3.2 General equations

In a general problem the flow pattern depends on the following differential equations:

- the law of linear resistance

$$(1) \quad q_x = -kD \frac{\partial \varphi}{\partial x} \quad q_y = -kD \frac{\partial \varphi}{\partial y}$$

- the law of continuity

$$(2) \quad \frac{\partial q_x}{\partial x} + \frac{\partial q_y}{\partial y} = N$$

where

$N = 0$ in the case of a confined aquifer,

$N = n - \mu \frac{\partial \varphi}{\partial t}$ in the case of a phreatic aquifer,

$N = n - \mu' \frac{\partial \varphi'}{\partial t} = \frac{k'}{D'} (\varphi' - \varphi)$ in the case of a partly confined aquifer.

These equations apply to steady as well as to nonsteady flow. They relate φ , q_x and q_y to x and y (and to t in the case of nonsteady flow).

From the equations (1) and (2) q_x and q_y can be eliminated, so as to obtain a differential equation in φ only

$$(3) \quad \frac{\partial^2 \varphi}{\partial x^2} + \frac{\partial^2 \varphi}{\partial y^2} = - \frac{N}{kD}$$

Integration gives φ as a function of x and y (and t). Once φ is known, the quantities of q_x and q_y are determined by Equation (1).

In principle the reverse procedure can also be applied: eliminating φ between (1) and (2), so as to obtain differential equations in q_x and q_y . This operation, however, is only elegant if N is independent of φ (and $\partial\varphi/\partial t$), for instance in the case of steady flow in a confined or phreatic aquifer. The result is

$$(4) \quad \frac{\partial q_x}{\partial y} = \frac{\partial q_y}{\partial x}$$

to be combined with

$$(2) \quad \frac{\partial q_x}{\partial x} + \frac{\partial q_y}{\partial y} = N$$

Integration of these equations gives q_x and q_y as functions of x and y (and t). Determination of φ requires further integration of Equation (1).

As previously stated, these differential equations are the formulation of general laws governing whole classes of flow systems. For example the formula

$$\frac{\partial^2 \varphi}{\partial x^2} + \frac{\partial^2 \varphi}{\partial y^2} = \frac{\mu}{kD} \frac{\partial \varphi}{\partial t}$$

which is a special case of Equation (3), applies to any nonsteady groundwater movement in an aquifer with constant D , receiving no recharge N . The system may be parallel, radial or two-dimensional; the variations of φ with time may be periodical, steadily rising, etc. The individual systems are determined by further conditions (boundary conditions, initial conditions), to be examined next.

1.3.3 Boundary and initial conditions

Boundary conditions of two-dimensional flow patterns show so much variety that it would be difficult to give a general rule as to their nature or their number. The examples will be limited to steady flow, with n given as a function of x and y , (excluding, in particular, flow in partly confined aquifers with φ' given; these systems will be analyzed in Chapter 4).

Figure 9a. - If φ is given at each point of a closed boundary A, the flow system inside

Fig. 9

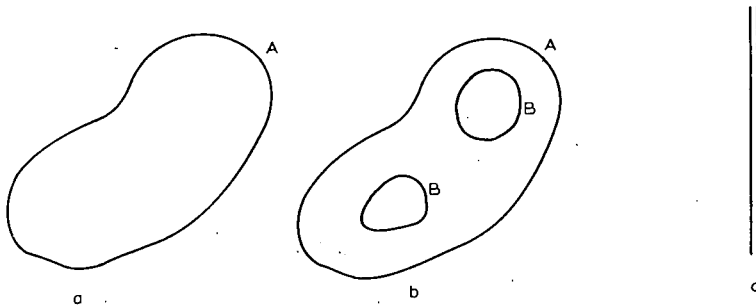

the boundary is determined for n given as a function of x and y . The system outside the boundary, however, is not defined: a second condition is required, e.g. $\varphi = \varphi_0$ at infinite distance in all directions. To avoid difficulties arising from recharge of an infinite aquifer, it is assumed in this example that $n = 0$ outside the boundary A.

Figure 9b. – The system inside A is also defined if in the field one or more closed boundaries B exist, where φ is given at each point. These boundaries may also be impermeable, in which case the condition reads that in any point the flow component perpendicular to the boundary is zero.

If the boundaries B reduce to the circumferences of wells, it should be noted that φ is equal at all points of the well face, so that a single value φ_0 , the potential of the well, suffices to determine the problem. Since moreover the dimensions of the well are small compared with those of the aquifer, the flow immediately around the well is radial, with equal values q_0 of q on all radii, and a total discharge $Q_0 = 2\pi r_0 q_0$, where r_0 is the radius of the well. Thus the problem can be defined equally well by giving Q_0 instead of φ_0 .

A particular instance of the above arrangement is a single well, pumped at a rate Q_0 , sited in the centre of a circle with $\varphi = \varphi_1$, while $n = 0$. The problem would not change essentially if the radius of the boundary circle increased infinitely. However, for φ_2 remaining constant, the φ values at finite distance from the well would become infinitely low. If instead of Q_0 the potential of the well had been given, the flow rate would reduce to zero. This result will be re-examined in Section 2.3.1.

Figure 9c. – If a well is sited at some distance from an infinitely long, straight canal, the flow system in the half-plane containing the well is determined for:

- $n = 0$
- In the canal $\varphi = \varphi_1$
- At infinite distance from the well in any direction $\varphi = \varphi_1$
- In the well $\varphi = \varphi_0$, or $Q = Q_0$

For nonsteady flow the same boundary conditions apply; however, neither the values

of φ or q at the boundaries, nor the recharge n need be constant: they may vary with time. Theoretically these data suffice to determine the groundwater movement if they are given from a remote past onwards, theoretically from an infinitely remote past. This is feasible if, for instance, they are given as constants or as periodic functions of time. If some of these quantities, however, vary in a more arbitrary way, it is convenient to resume at a time $t = 0$ the influence of all previous changes in boundary conditions and recharge by describing the flow pattern at that moment, giving φ (or q) as a function of x and y (initial condition). From that moment onwards φ or q at the boundaries, as well as the recharge n , must be given as functions of time.

A distinction should be made between confined and phreatic aquifers (disregarding partly confined aquifers, which will be discussed in Chapter 5). Confined aquifers receive no discharge because of their impermeable cover; they are under the sole influence of the boundary conditions. The reaction is immediate, since the change in flow pattern is only a change in pressure, while the propagation of pressure waves is infinitely rapid under the assumed conditions of incompressible water and soil, without inertia. Thus a nonsteady movement in a confined aquifer is a succession of steady state flow patterns, each of them corresponding to the boundary conditions of the moment. Clearly no initial condition is needed to define the movement.

The mechanism is different in a phreatic aquifer, where the water table constantly tends to adapt its form to the steady state form corresponding to the boundary conditions and n values of the moment. Any deformation of the water table, however, requires time, because volumes of water must be displaced. Hence the system is engaged in a continuous process of adaptation to the ever-changing conditions imposed upon it, and always lagging behind. Should these conditions remain constant from a certain moment onwards, the system would gradually approach the corresponding steady state, reaching it theoretically after an infinitely long time.

Two-fluid systems are comparable with single systems as regards boundary and initial conditions, the only difference being that all conditions must be doubled: a complete set is required for each fluid layer. When, for instance, fresh water is extracted from a well, the double boundary condition reads: (1) extraction Q_0 from the fresh water layer, (2) zero extraction from the salt water. Along the coast the conditions read: (1) the salt water potential corresponds to sea level, (2) the fresh water section reduces to zero. As to the initial conditions in a phreatic aquifer, the values of φ (fresh water potential) as well as φ'' (salt water potential) must be given as functions of x and y , or what is mathematically equivalent to this, the form of both the water surface and the interface.

In confined aquifers, which by definition are without recharge, two-fluid systems can only develop when the fresh water body is supplied laterally from adjacent zones. Although the propagation of pressure waves is instantaneous, the system will not

immediately assume the steady state corresponding to the instantaneous boundary conditions, as the deformation of the interface requires time.

In a phreatic two-fluid system both the water surface and the interface undergo a change in form during a nonsteady period. The movement of the interface is particularly slow. The time of adaptation to steady boundary conditions is therefore much longer for a two-fluid system than for a one-fluid system filling the same aquifer. It may be of the order of tens of years or even longer. Groundwater in aquifers of coastal regions is seldom in a steady state when any technical intervention has taken place in the last decades.

1.3.4 Methods of integration

So far, the flow problems have only been discussed in principle; the practical question as to whether or not the integration can be executed has not been examined. Actually, the number of solutions found up to now have been strongly limited by the difficulty of the mathematical operations involved. Apart from formal integration, other methods of solution have been developed. The main methods now in use are:

A general solution of the differential equations (in terms of complex numbers) can only be given for steady flow without recharge. Each particular solution depends on an arbitrarily chosen function. Once the function is chosen, the boundary conditions for a given circumference can be determined, but the converse is not true: from given boundary conditions the function cannot be determined. The theory concerning this point is developed in Section 2.4.

A certain number of solutions have been found by direct integration of differential equations. They apply for the greater part to steady parallel or radial flow, where φ and q depend on one single coordinate. Examples are given in several chapters.

Only in a few cases have nonsteady systems been described by analytic functions, generally for parallel or radial flow. Most solutions have been found accidentally as particular solutions of the partial differential equations. A general method for integration does not exist. Some of these solutions are to be found in Chapter 5.

In Chapter 7 iteration methods will be described enabling the calculation of steady or nonsteady flow systems inside a closed boundary of arbitrary form, along which φ is given numerically. (If q is given the method lacks elegance). The quantity n is given in arbitrary distribution over the aquifer. Iteration methods may be executed with computers. Computer technics, however, will not be treated. The theory given in Chapter 7 has been restricted to providing the reader with a basic knowledge, which will enable him to carry out simple studies by himself, or to discuss more complicated problems with a computer engineer.

In some cases graphical methods can be used. These, however, are more commonly

applied in relation to flow through dams and similar problems, where vertical flow components are involved. They will not be discussed.

Finally, model tests may be chosen to solve the problems: scala models, filled with a liquid flowing through a porous medium or analogue models, e.g. containing a viscous fluid between two parallel plates a short distance from one another, or models based on the mathematical analogy between electrical fields and potential flow patterns. None of these model technics will be discussed.

1.3.5 Dimensions

In physical formulas each symbol stands for the product of a number and a unit. The equation expresses the equality of the members from a qualitative as well as a quantitative viewpoint. This double condition implies that

- both members have the same dimension,
- in any sum occurring in the equation, the terms have the same dimension,
- the arguments of analytical functions are pure numbers.

For example, in one of the problems of nonsteady flow the relation between the potential φ , the place x and the time t is given by

$$\varphi = \varphi_1 + \varphi_0 e^{-ax} \sin(\omega t - ax)$$

The dimensions of the constants a and ω are such that the products ax and ωt are dimensionless. Thus the arguments of both the exponential and the sine function are pure numbers. The constants φ_1 and φ_0 have the dimensions of the potential φ .

When differentiating with respect to x , the left-hand member changes from φ into $\partial\varphi/\partial x$; hence its dimension is divided by a length. The right-hand member is first differentiated with respect to ax , a number, which operation does not change its dimension, and then multiplied by $d(ax)/dx$ or a , which multiplies the dimension by the dimension of a . Since ax is a number, a has the inverse dimension of a length, and by multiplication with a the qualitative equality with the left hand member is re-established. Differentiation with respect to t gives rise to similar considerations.

Hydraulic problems depend on the dimensions of length, mass and time. Accordingly a flow system is defined by at least three physical quantities of different dimensions, depending on length, mass and time. For instance the problem of steady flow around a well in an infinite, partly confined aquifer with constant $\varphi' (= 0)$, depends on the transmissivity kD of the aquifer for horizontal flow, the transmissivity k'/D' of the top layer for vertical flow, and the extraction rate Q_0 from the well. This number of three quantities is a minimum; the scheme may depend on more parameters, for instance when there are more wells at different distances and pumped at different rates, or when φ' varies from one area to another.

The number of variables happens to be at least three as well: in the simplest systems,

those of steady, parallel flow, ϕ and q depend on x . But this number may also be greater: in a more general system, ϕ , ϕ' , q_x and q_y may be functions of x , y and t , which brings the number of variables up to seven.

In problems which call for a difficult mathematical treatment, it may be convenient to simplify the formulas in the following way. Three characteristic constants defining the problem are chosen as a base. They should have different dimensions and depend on length, mass and time. They are used to form dimensionless groups with each of the variables and each of the constant quantities defining the problem. In the scheme of the well sited in a partly confined aquifer with kD , k'/D' and Q_0 as basic quantities, the three variables ϕ , Q and r appear in the following dimensionless groups

$$\frac{kD}{Q_0} \phi, \quad \frac{Q}{Q_0}, \quad r \sqrt{\frac{k'/D'}{kD}}$$

The differential equations read (for $\phi' = 0$):

Law of linear resistance:

$$Q = 2\pi kDr \frac{d\phi}{dr}$$

Law of continuity:

$$\frac{dQ}{dr} = \frac{k'}{D'} 2\pi r \phi$$

while the boundary conditions are:

$$\text{for } r = r_0 \text{ (radius of the well), } Q = Q_0$$

which may be replaced by

$$\text{for } r = 0, Q = Q_0,$$

$$\text{and for } r = \infty, \phi = 0$$

When writing ϕ instead of $\frac{kD}{Q_0} \phi$, Q instead of $\frac{Q}{Q_0}$, and r instead of $r \sqrt{\frac{k'/D'}{kD}}$, the dif-

ferential equations become

$$Q = 2\pi r \frac{d\phi}{dr}$$

$$\frac{dQ}{dr} = 2\pi r \phi$$

and the conditions

for $r = 0$, $Q = 1$

for $r = \infty$, $\varphi = 0$

The problem is then formulated in relations free from physical constants and can be solved in its most general form.

As can be seen from the example, only two of the basic constants (kD and k'/D') appear in the differential equations, whereas the third constant, Q_0 , occurs in the conditions only. This difference plays a role in the theory on solutions in terms of complex numbers (Sections 2.4.1). These solutions apply to steady, two-dimensional flow in an aquifer with constant D , receiving no recharge. The differential equations are

$$q_x = -kD \frac{\partial \varphi}{\partial x} \quad q_y = -kD \frac{\partial \varphi}{\partial y}$$

$$\frac{\partial q_x}{\partial x} + \frac{\partial q_y}{\partial y} = 0$$

The general solution of the equation can be formulated in terms of complex numbers. It involves all particular solutions, each determined by its own boundary conditions, i.e. by at least three physical constants, of which only one, kD , occurs in the differential equations. Thus, dimensionless groups with the variables φ , q_x , q_y , x and y can be formed for each scheme separately, but since they differ from scheme to scheme, they cannot be used when formulating the general solution of the differential equations, or establishing its general properties.

Yet it is customary to delete kD in the general theory, reasoning that in each particular scheme two other physical constants can be added to kD to form dimensionless groups. Under this assumption the general solution may be written

$$\varphi + i\psi = F(x + iy)$$

where ψ is a variable, to be defined in Section 2.4.1, and F is an arbitrary analytical function. It is understood that x and y , as well as φ and ψ , are dimensionless groups, to be formed in each system separately in dependence of the constants defining the problem.

2. STEADY FLOW, CONSTANT D , GIVEN n

In this chapter three types of aquifers physically different, but mathematically identical, will be examined.

1. A phreatic aquifer with constant thickness D (as an approximation). – The laws of linear resistance and continuity read respectively:

$$(1) \quad q_x = -kD \frac{\partial \varphi}{\partial x} \quad q_y = -kD \frac{\partial \varphi}{\partial y}$$

$$(2) \quad \frac{\partial q_x}{\partial x} + \frac{\partial q_y}{\partial y} = N$$

Since for steady flow $\partial \varphi / \partial t = 0$, the general formula $N = n - \mu (\partial \varphi / \partial t)$ reduces to

$$N = n.$$

2. A partly confined aquifer. – The differential equations are the same. The expression for N reads for steady flow:

$$N = n = \frac{k'}{D'} (\varphi' - \varphi)$$

The method of solution varies according to the way the problem is defined.

– If n is given as a function of x and y , the first two members of the above expression, in combination with the differential equations, define the problem in exactly the same way as in the case of a phreatic aquifer. The method of solution is identical, and gives φ as a function of x and y . Once φ is known, φ' can be determined, also as a function

of x and y , from the last two members of the equation. If, for instance, the distribution of n over the aquifer is uniform, the value of $\varphi' - \varphi$ is constant. In geometrical representation: the φ' surface is at a constant height above the φ surface.

– If φ' is given as a function of x and y , or as a constant, the problem assumes another character. The two differential equations are then to be combined with

$$N = \frac{k'}{D'}(\varphi' - \varphi)$$

and φ must be determined as a function of x and y by means of a different integration. Once φ is known, n can be found as a function of x and y from

$$n = \frac{k'}{D'}(\varphi' - \varphi)$$

Problems of this kind will be examined in Chapters 4 and 7.

3. A confined aquifer. – The recharge n is zero because of the impermeable cover. The differential equations are the same as those of a phreatic aquifer, while

$$N = n = 0$$

2.1 SUPERPOSITION

2.1.1 The principle

In the following chapters the principle of superposition will be frequently used. Since its application varies according to the nature of the aquifer, its precise formulation will be given in each chapter separately. In the present chapter the problem will be limited to steady flow in aquifers with constant thickness D , where n is a given function of x and y . The principle will be shown in an example.

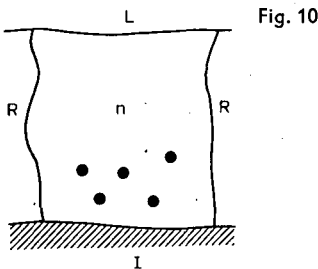

Figure 10. – To give the example a general character, boundaries of different nature are assumed: an impermeable rock wall I , two rivers R and a lake L (a lake rather than the sea, to avoid the complications of salt water intrusion). From this aquifer water is extracted by means of a number of wells.

This description defines what will be called a model, this term taken in the sense of any material arrangement, either in nature or in the laboratory. On the given model several flow systems can be imposed, defined by the following hydraulic data:

- The recharge n as a function of x and y .
- The water levels in the rivers and the lake, determining φ along the borders.
- A given supply of water along the rocky outcrop I , as a function of the length coordinate along this boundary.
- The rates of extraction from the wells.

An arbitrarily chosen set of these values defines a flow system, which means mathematically that at each point (x, y) the values of φ and q (q_x and q_y) are determined.

The principle of superposition can be formulated as follows: If in a certain model two different flow systems, I and II, can be realised, it is also possible to realise a third system, III, in which the values of φ , q and n at each point are the sum of the corresponding values in Systems I and II. For φ and n this is the algebraic sum, for q the vectorial sum.

This summation applies to all points of the aquifer, in particular to the values of φ and q at the boundaries. As to the borders of the rivers and the lake, the superposition is valid for the values of φ as well as for the quantities of flow exchanged at each point between these waters and the aquifer. As to the wells, the well faces constitute boundaries of the aquifer. The superposition applies both to the values of φ in the wells, and to the rates of extraction.

This principle enables two or more elementary systems to be superposed, and conversely permits any given system to be separated into two or more elementary flow patterns. In the latter case the choice of the elementary systems is arbitrary, depending on the use to be made of the separation: it might, for instance, be different when the separation is needed for a calculation or for a demonstration.

Although superposition is one of the leading principles in calculation practice, its use is limited. In the following it will be applied to schemes where n is given, and sometimes to partly confined aquifers where φ' is given. Yet other problems exist where in phreatic or partly confined aquifers the water level is near the surface, so that evaporation depends on the elevation of the water table, and thus n is related to φ or φ' . These cases occur frequently in irrigation and drainage problems. Although the principle of superposition remains valid, it is no longer feasible to distinguish elementary systems depending on given quantities only.

| The demonstration starts from the mathematical condition that if in the given model System I can be realised, the quantities φ_I , $(q_x)_I$, $(q_y)_I$ and n_I satisfy the differential equations and the boundary conditions. The same is true for System II.

As regards the quantities

$$\begin{aligned}\varphi_{III} &= \varphi_I + \varphi_{II} \\ (q_x)_{III} &= (q_x)_I + (q_x)_{II} \\ (q_y)_{III} &= (q_y)_I + (q_y)_{II} \\ n_{III} &= n_I + n_{II}\end{aligned}$$

they represent again a flow system, System III, if they also satisfy the differential equations and the boundary conditions. For the boundary conditions this is true by definition of the problem; for the differential equations the proof is given by summation of the (linear) equations, as follows:

The law of linear resistance (e.g. for the x direction) reads System I:

$$q_I = -kD \frac{\partial \varphi_I}{\partial x}$$

System II:

$$q_{II} = -kD \frac{\partial \varphi_{II}}{\partial x}$$

After summation, using the premiss that D is the same in both systems:

$$q_{III} = -kD \frac{\partial \varphi_{III}}{\partial x}$$

The law of continuity reads

System I:

$$\frac{\partial (q_x)_I}{\partial x} + \frac{\partial (q_y)_I}{\partial y} = n_I$$

System II:

$$\frac{\partial (q_x)_{II}}{\partial x} + \frac{\partial (q_y)_{II}}{\partial y} = n_{II}$$

After summation

$$\frac{\partial (q_x)_{III}}{\partial x} + \frac{\partial (q_y)_{III}}{\partial y} = n_{III}$$

2.1.2 *Water resources*

In regional studies on the possibilities of groundwater extraction, the fundamental question to be answered is the maximum rate at which groundwater can be withdrawn

Fig. 11

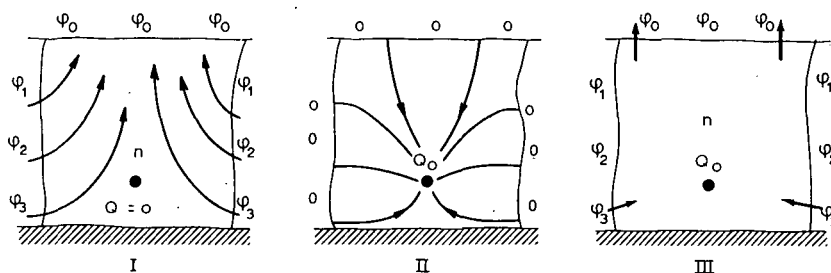

from an aquifer or a certain geographical area. The phrase groundwater resources is used, but the term is misleading since it is also used for mineral or oil resources. Whereas in the latter case the quantities to be extracted are limited by the quantities present in the ground, in the case of groundwater the quantities present are replenished by recharge from rainfall or irrigation, as well as by lateral infiltration from adjacent water courses. The expression safe yield is also used, but the term has not always been defined in the same way.

In view of the mainly didactic character of the present study, no exhaustive discussion of the problem will be attempted, and the definition of the terms in question will be left open. The aim is rather to analyse the problem on its main points, so as to provide the basis for a complete study. The analysis varies according to the character of the aquifer. Therefore the question of water resources will be taken up again in each chapter. The best insight can be gained from this section, the corresponding parts in the following chapters having more or less the character of additional remarks, with the exception of Chapter 6, where the intrusion of saline water comes to the fore as a factor strongly limiting the yield of the aquifer (see Section 6.1.2).

Figure 11. - The model of the previous section will be used as a basis for the analysis: first with one well, then with several wells. Two systems, I and II, will be considered, whose sum is System III:

System I is defined by:

- The true values of φ in the rivers and the lake.
- The true n values.
- The true supply along the rocky border.
- No extraction from the well.

System II by:

- $\varphi = 0$ in the rivers and the lake.
- $n = 0$
- No supply along the rocky border.
- The true extraction Q_o from the well.

It follows that System III is defined by:

- The true φ values in the rivers and the lake.
- The true n values.
- The true supply along the rocky border.
- The true extraction Q_0 from the well.

Physically these systems may be interpreted as follows:

System I is the natural state before water was extracted from the well.

System II is the change in state brought about by the extraction.

System III is the final state of the aquifer under exploitation.

From this analysis several important conclusions can be drawn with respect to the exploitation of the wells. First the system with one well will be examined. The drawdown in the well, by definition the difference between the levels before and during exploitation, is equal to the φ value of System II. Since the basic laws of groundwater flow are linear, the drawdown is proportional to the rate of extraction. Hence the specific capacity of a well can be defined as the yield per unit drawdown, or its reverse, the specific drawdown, as the drawdown per unit rate.

The specific capacity of a well is determined by System II only. It depends on: (1) the form and the nature of the boundaries of the aquifer, and the position of the well with respect to them, (2) the transmissivity kD of the aquifer, and (3) the diameter of the well. It is independent of: (1) the levels of the lake and the rivers, (2) the recharge n , and (3) the supply along the rocky border. Thus it is independent of the original flow pattern, as defined by System I. Finally it is clear that under the conditions of the present chapter the well has no radius of influence: its influence extends to the boundaries of the aquifer.

If several wells are exploited in the same aquifer, they interact. Several elementary systems, IIa, IIb, IIc, etc. may then be distinguished, each taking one well into account. The interaction corresponds mathematically to the superposition of these systems. The calculation is a straightforward one when the extraction rates of the wells are given; an iteration procedure must be used in the reverse case, when the extraction rates are to be determined at such values as to create given drawdowns in the wells. Methods of calculation, however, will not be discussed here; only the hydraulic aspects of the problems will be analyzed.

System II shows that the quantity of water extracted from the wells is counterbalanced by a change of the flow passing through the boundaries with the lake and the rivers. Under natural conditions these water courses receive the full recharge of the aquifer. When water is extracted from the wells, the water courses receive only a part of this recharge, and if the extraction exceeds the recharge, they supply the excess. The quantity extracted from the wells appears for the full amount in the water balance of the water courses.

If the surrounding water courses can supply unlimited quantities of water, the maximum extraction from a given set of wells (given site and diameter) depends finally on the maximum drawdown in the wells to be admitted. This maximum drawdown is determined by:

- Formal considerations. – According to the premisses of this chapter, the water level in the well should not fall below the basis of the top layer in the case of confined or partly confined aquifers, while in the case of a phreatic aquifer the drawdown should be small compared with D .
- Technical considerations. – The characteristics of certain pumps to be used may limit the water lift. The drawdown should also be limited, so as to leave sufficient water height in the aquifer for screens of adequate length.
- Economic considerations. – The water lift may be restricted by a maximum allowable pumping cost per unit water volume. This cost should always be compared with the cost of conveying the water through canals or pipelines from the surrounding water courses to the site of the well.

If the number and the site of the wells can be chosen freely to obtain the maximum yield from the aquifer, the problem loses interest. By sinking a sufficient number of wells along, and close enough to the bordering water courses, the yield can be increased at will. The exploitation no longer bears the character of extraction from the aquifer, but of indirect extraction from the water courses.

If the bordering water courses are exploited, or if their contribution is limited by natural factors, their water balance should be considered. As long as no water is extracted from the aquifer, the water courses receive the full recharge of the aquifer. If their water balance allows for a reduction of this flow by ΔQ at a maximum, the extraction from the aquifer is limited to that rate. If their exploitation does not admit any reduction of the inflow, no water can be extracted from the aquifer at all. The problem is comparable to that of extraction from the upper course of a river, when the full discharge or a part of it is used downstream. No water can be extracted without considering the interests downstream.

Finally, the water in the bordering water courses may be of inferior quality, and unfit for use. The classical example is sea water, but the discussion of this case will be postponed to Chapter 6, as the difference in density between the fluids modifies the flow pattern considerably. Slightly saline water, or water containing other undesirable constituents will be assumed.

The problem depends too much on details, to be treated in a systematic way: the chemical composition of the water along the boundary may not be uniform, or extraction of impure water may be tolerated to some extent when the water used is mixed with good quality water from the aquifer. In any particular problem the study should be made on System III, which gives the actual flow lines, and in particular the actual

flow vector at any point of the boundary, indicating the inflow of impure water into the aquifer. From this system the quantity of impure water extracted by any of the wells can be determined, as well as the period of time that elapses before this water reaches the well. This time period may be tens of years.

For didactic reasons the discussions have been placed on a strongly schematised basis. To bring the problem nearer to engineering practice some additional factors will be introduced.

1. It has been assumed that the recharge in Systems I and II is the same. But if the water extracted is used for irrigation in the region itself, a part of it will return to the aquifer as seepage. The quantity Δn of this supplementary recharge, as well as its distribution over the area, can be estimated. To account for this supply an additional flow system can be superposed on the others characterized by:

- Δn as the only recharge
- $\varphi = 0$ in the bordering canals
- no supply at the rocky border
- no extraction from the wells.

Since the return flow from irrigated fields is saline, the qualitative aspects may need study. If any investigation on this point is required, it can be based on the sum of the elementary flow systems. This flow pattern indicates along what paths and at what speed the introduced salt is carried through the aquifer.

2. Systems I and III both represent steady flow. The water levels of System III are lower than those of System I when the aquifer is phreatic or partly confined. As long as the water table was falling, water was released which has not been accounted for in the above discussion. It is gained but once, and may be of small interest compared with the quantities extracted in a series of years, but it does constitute a yield of the aquifer.

3. It was assumed in all problems that the recharge n is given, which implies that the water table is so deep under the surface that evaporation of groundwater is negligible (more than 2 or 3 m deep in moderate climates). If, however, in the initial state the water table is near the surface over the whole area or a part of it, evaporation does play a role, and n becomes a function of the water depth. Moreover, lowering of the water table generally causes a change in the natural vegetation, which in the case of land reclamation will even be replaced by crops. Finally, on irrigated lands, water is supplied according to the need, which in turn depends on depth to water table, evaporation and crops.

This complex problem is no longer governed by simple hydraulic laws. It will not be dealt with here; only some marked differences will be listed, which may form as many starting points for detailed studies.

- It is virtually still possible to distinguish two systems, I and II, whose sum is III, I

being the original, and III the final state, but the quantities n_I , n_{II} and n_{III} are no longer given.

- The influence of a well no longer extends to the boundaries at all sides, as is discussed for a particular case in Section 2.3.2.
- The drawdown in a well is no longer proportional to the discharge rate, as can be seen from the formulas of the same section.
- The interference of the wells no longer corresponds to the superposition of elementary systems.
- The yield of the wells is no longer counterbalanced by diminution of the outflow towards the bordering canals only; reduction of evaporation appears as a further term in the water balance of the aquifer.

2.2 PARALLEL FLOW

In this section the principle of superposition will be applied to some of the simplest schemes.

2.2.1 Two canals

Figure 12 represents parallel flow in an aquifer bounded by two long, parallel canals. Three flow systems will be studied in this model, indicated by I, II and III respectively, System III being the sum of I and II. The differential equations and their general solution have been given in Section 1.3.1 (Equation (5) defining φ and Equation (6) defining q). Thus the formulas can be applied directly to the present systems. The results are given below. The φ diagrams are shown in the bottom part of the figure. System I is characterized by

- Potentials φ_1 and φ_2 of the canals A and B respectively.
- No recharge ($n = 0$).

The formulas are:

$$\varphi_I = \varphi_1 - \frac{x}{l}(\varphi_1 - \varphi_2)$$

$$q_I = -kD \frac{\varphi_1 - \varphi_2}{l}$$

φ_I is a linear function of x , corresponding to a straight line in the figure; q_I is a constant (independent of x).

System II is defined by

- Zero potentials in both canals.
- Uniform recharge n .

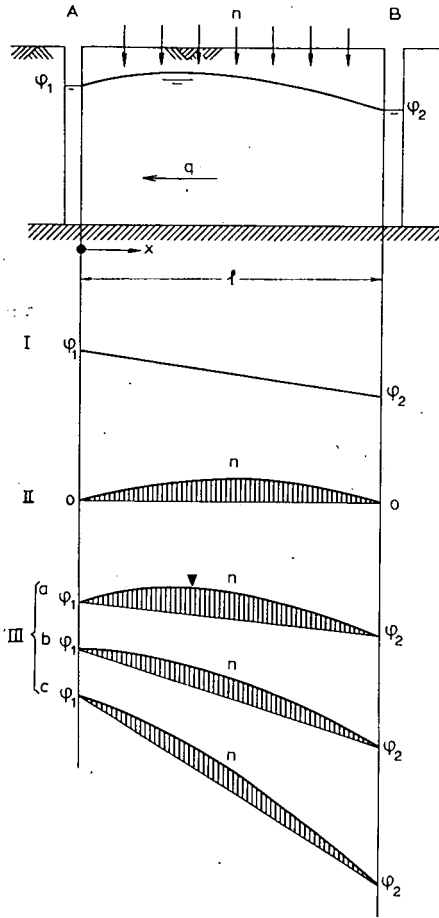

Fig. 12

The formulas are

$$\varphi_{II} = \frac{n}{2kD} x(l-x)$$

$$q_{II} = n \left(\frac{l}{2} - x \right)$$

\$\varphi\$ is a second degree function of \$x\$, corresponding in the figure to a parabola, symmetrical about the middle section of the figure. The value of \$\varphi\$ in the middle section is

$$\varphi_m = \frac{nl^2}{8kD}$$

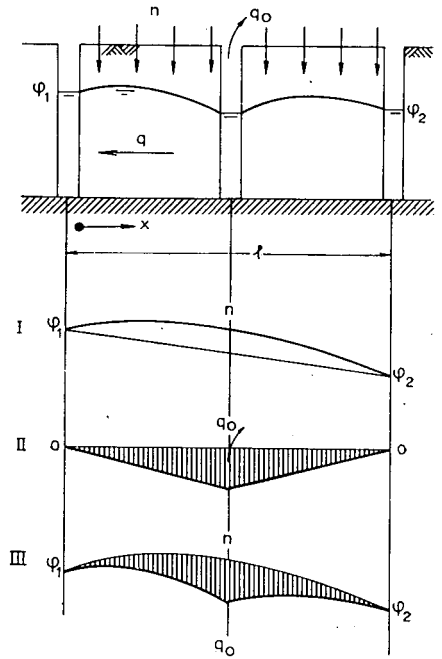

Fig. 13

q is a linear function of x , zero in the middle section. The quantities flowing into the canals are equal and opposite.

System III, being the sum of Systems I and II, is defined by

- Potentials φ_1 and φ_2 of the canals.
- Recharge n .

The formulas of this system can be written forthwith as the sum of the above mentioned.

$$\varphi_{III} = \varphi_1 - \frac{x}{l}(\varphi_1 - \varphi_2) + \frac{n}{2kD} x(l - x)$$

$$q_{III} = -kD \frac{\varphi_1 - \varphi_2}{l} + n \left(\frac{l}{2} - x \right)$$

As a corollary it may be remarked that for $n = 0$ the formulas reduce to those of System I; for $\varphi_1 = \varphi_2 = 0$, to those of System II.

The characteristics of System III vary with the sign of q_{III} for $x = 0$, as shown in the figure.

- System IIIa: q_{III} is positive (flow to the left). The water level reaches a top on the left-hand side of the figure.
- System IIIb: $q_{III} = 0$. The discharge into the canal on the left-hand side reduces to zero; the flow in the aquifer is towards the right throughout.
- System IIIc: q_{III} is negative (flow to the right). The canal on the left feeds the aquifer.

In the three cases the superposition is shown by the shaded parts of the figure, whose ordinates are equal to those of System II.

2.2.2 Three canals

Figure 13 shows a model with three parallel and equidistant canals. The flow scheme is defined by:

- Uniform recharge n .
- Potentials φ_1 and φ_2 in the outer canals.
- Extraction q_0 per unit length from the middle canal.

It has been indicated in Section 1.3.1 how φ and q can be determined as functions of x . However, the solution can be established more readily by using the principle of superposition. The present system, to be called III, will therefore be considered as the sum of two others, I and II. The systems are characterized as follows (the respective φ lines being indicated in the bottom part of the figure).

System I:

- Recharge n .
- Potentials in the outer canals φ_1 and φ_2 .
- No extraction from the middle canal.

This is the system examined in the previous section. The formulas can be repeated:

$$\varphi_I = \varphi_1 - \frac{x}{l}(\varphi_1 - \varphi_2) + \frac{n}{2kD}x(l-x)$$

$$q_I = -kD \frac{\varphi_1 - \varphi_2}{l} + n \left(\frac{l}{2} - x \right)$$

System II:

- No recharge.
- Potentials in the outer canals zero.
- Extraction from the middle canal q_0 .

The formulas (valid for the left part of the symmetrical model) need no further explanation after the foregoing.

$$\varphi_{II} = -\frac{q_0 x}{2kD}$$

$$q_{II} = -\frac{q_0}{2}$$

The formulas of System III can be found by summation:

$$\varphi_{III} = \varphi_1 - \frac{x}{l}(\varphi_1 - \varphi_2) + \frac{n}{2kD}x(l-x) - \frac{q_0 x}{2kD}$$

$$q_{III} = -kD \frac{\varphi_1 - \varphi_2}{l} + n \left(\frac{l}{2} - x \right) - \frac{q_0}{2}$$

In the figure the ordinates of the shaded parts are equal. The figure shows an example of the general proposition formulated in Section 2.1.2: The drawdown in the canal for a given extraction rate q_0 is independent of the original flow (of System I).

Figure 14. - An interesting conclusion can be drawn when the superposition is repeated for $n = 0$. In each of the systems, q is then a constant in both halves of the aquifer. The problem is: If in System I the flow rate in absolute value is q_1 , what rate q_0 may be extracted from the middle canal, so that no water flows into the aquifer from the canal on the right? The answer is

$$q_0 = 2q_1$$

as can be deduced from the figure.

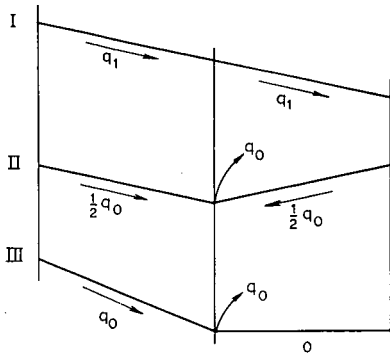

Fig. 14

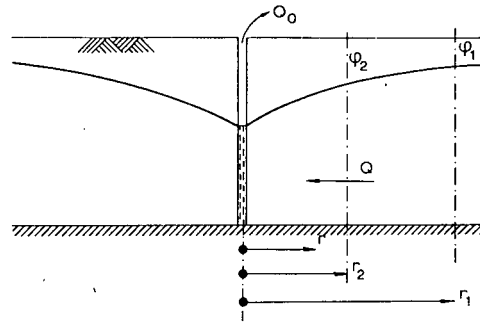

Fig. 15

2.3 FLOW AROUND WELLS

2.3.1 Infinite aquifer

Figure 15. – The model is defined by a well, sited in an aquifer with constant D , extending infinitely in all directions. On this model a flow system is imposed, which is characterised by:

- Constant extraction Q_0 from the well.
- No recharge of the aquifer.

These characteristics do not fully define the flow system, but they allow the following formula for φ to be established:

$$\varphi_1 - \varphi_2 = \frac{Q_0}{2\pi kD} \ln \frac{r_1}{r_2}$$

where r_1 and r_2 are two arbitrary distances from the centre of the well, and φ_1 and φ_2 the corresponding potentials.

The laws of linear resistance and continuity read respectively

$$(1) \quad Q = 2\pi kDr \frac{d\varphi}{dr}$$

$$(2) \quad Q = Q_0 = \text{constant}$$

(Q positive towards the well, r positive in opposite direction). Eliminating Q and integrating:

$$\varphi = \frac{Q_0}{2\pi kD} \ln \frac{r}{c}$$

where c is an integration constant.

Substituting successively

$$\text{for } r = r_1 \quad \varphi = \varphi_1$$

$$\text{for } r = r_2 \quad \varphi = \varphi_2$$

and subtracting

$$\varphi_1 - \varphi_2 = \frac{Q_0}{2\pi kD} \ln \frac{r_1}{r_2}$$

It follows from this formula that if the system is defined by a given potential at infinite distance from the well, the drawdown in the well is infinitely great. If, conversely, the potential in the well is given, the potential at infinite distance is infinitely high. As a conclusion, under the given conditions the problem of a well in an infinite aquifer does not correspond to any reality, although a mathematical solution exists.

Yet the formula derived has a certain value. If the flow system is of a nature other than described here, it may approximately satisfy the conditions of the present section for small values of r . Examples will be given for a partly confined aquifer with given φ' in Section 4.3.3 and for nonsteady flow in Section 5.5. In these cases the formula in question applies to the vicinity of the well. It may therefore, under certain well to be checked conditions, be used for the interpretation of pumping test data obtained from observation wells sited near the pumped well.

2.3.2 Radius of influence

In extensive flat country under natural conditions, the groundwater table shows no gradient of any importance. Hence the groundwater balance in not too small an area, say a square kilometre, is mainly determined by the recharge of the aquifer and the evaporation from the groundwater table, while the lateral groundwater movement is negligible.

In a climate with average or ample rainfall the water table cannot stay permanently at great depth, where evaporation from the water table is negligible (depths of more than say 3 m), because in some periods of the year at least, recharge from rain would occur, which in the absence of evaporation or lateral flow, would cause the water table to rise. Nor can it stay permanently at the surface of the soil, because in other periods of the year evaporation would lower it. Thus, in the course of the year the water table fluctuates in the upper 2 or 3 m of the soil. Similar conditions may exist in irrigated or drained lands.

Figure 16. – If water is extracted from a phreatic or partly confined aquifer, the level in the well being lowered to more than, say, 3 m below the surface, three zones can be distinguished:

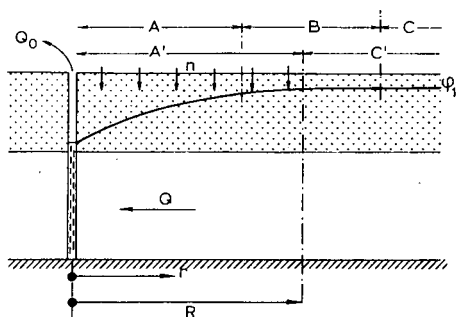

Fig. 16

Zone A, where evaporation from the groundwater table is negligible, while a recharge n is received from percolation through the root zone.

Zone B, where the groundwater table is lowered under the influence of the well, but to less than 2 or 3 m below the ground surface. Evaporation is less than under natural conditions, so that the aquifer does receive recharge, but at a rate lower than n .

Zone C, where the groundwater level is practically no longer influenced by the well, as the recharge of the zones A and B corresponds to the extraction rate of the well.

An exact calculation of the nonsteady flow during the year, taking into account the relationship between evaporation and water level in Zone B, would be complicated. A first rough estimate may be made based on the following steady-state flow scheme, where Zone B is taken partly with A, partly with C. In this model two zones are distinguished:

Zone A', around the well, characterized by recharge n , assumed evenly distributed over the area, and constant during the year. The radius R of this zone is the radius of influence of the well.

Zone C', characterized by a constant water level, representing the average during the year under natural conditions. If the aquifer is phreatic, $\varphi = \varphi_1$, and if partly confined $\varphi = \varphi' = \varphi_1$. In the latter case φ and φ' are equal in Zone C'; they differ in Zone A', but only φ affects the calculation.

The model is defined by a well, sited in an aquifer with constant D . The water flows towards the well within a circle with radius R (the radius of influence). The flow system is defined by

- Uniform recharge n .
- Extraction Q_0 from the well.
- For $r = R$, $Q = 0$
- For $r = R$, $\varphi = \varphi_1$

Clearly the quantity Q_0 extracted from the well corresponds to the recharge over the surface area of the cone of depression

$$Q_0 = \pi R^2 n$$

Since Q_0 is given, this equation defines R .
The formulas are

$$\varphi = \varphi_1 - \frac{nr^2}{4kD} - \frac{Q_0}{4\pi kD} \left(\ln \frac{Q_0}{\pi r^2 n} - 1 \right)$$

$$Q = Q_0 - \pi r^2 n$$

At the well face, for $r = r_0$, with slight approximation

$$\varphi_0 = \varphi_1 - \frac{Q_0}{4\pi kD} \left(\ln \frac{Q_0}{\pi r_0^2 n} - 1 \right)$$

where the term within the brackets may often be neglected.

The simplest way to find the solution is by superposing two elementary systems, I and II, defined as follows:

System I:

- No recharge.
- Extraction Q_0 from the well.
- For $r = R$, $\varphi = \varphi_1$.

The solution has been given in Section 2.3.1:

$$\varphi = \varphi_1 - \frac{Q_0}{2\pi kD} \ln \frac{R}{r}$$

$$Q = Q_0$$

System II:

- Recharge n .
- No extraction from the well.
- For $r = R$, $\varphi = 0$.

For this system the laws of linear resistance and continuity read respectively,

$$(1) \quad Q = kD2\pi r \frac{d\varphi}{dr}$$

$$(2) \quad \frac{dQ}{dr} = -2\pi r n$$

Equation (2) can better be written directly in integrated form:

$$Q = -\pi r^2 n$$

It expresses that the water flowing through the cylinder with radius r equals the recharge received on the enclosed surface.

Eliminating Q

$$d\phi = -\frac{n}{2kD} r dr$$

Integrating

$$\phi = -\frac{nr^2}{4kD} + c$$

where c is the integration constant, to be determined from the condition for $r = R$, $\phi = 0$

Thus

$$\phi = \frac{n}{4kD} (R^2 - r^2)$$

By superposition

$$\phi_{III} = \phi_1 - \frac{Q_0}{2\pi kD} \ln \frac{R}{r} + \frac{n}{4kD} (R^2 - r^2)$$

$$Q_{III} = Q_0 - \pi r^2 n$$

From the expression for ϕ_{III} , R can further be eliminated, using

$$Q_0 = \pi R^2 n$$

which gives the formula indicated earlier.

2.3.3 Well near a canal

(The problem dealt with in this section is re-examined more comprehensively in Section 2.4.3, where the theory of complex numbers is applied).

As was shown in Section 2.3.1, a single well in an infinite aquifer does not correspond to a state of steady flow, since infinite potentials are involved, either in the well itself or at a great distance from it. However, a well discharging at a constant rate near a canal where a constant potential is maintained, brings about a steady flow system with finite potentials throughout the aquifer.

Figure 17. – The model consists of an aquifer with constant D , divided by an infinitely long straight canal into two halves, in one of which a well P is sited. The flow system is defined by

- Extraction Q_0 from the well
- Potential ϕ_c of the canal

Fig. 17

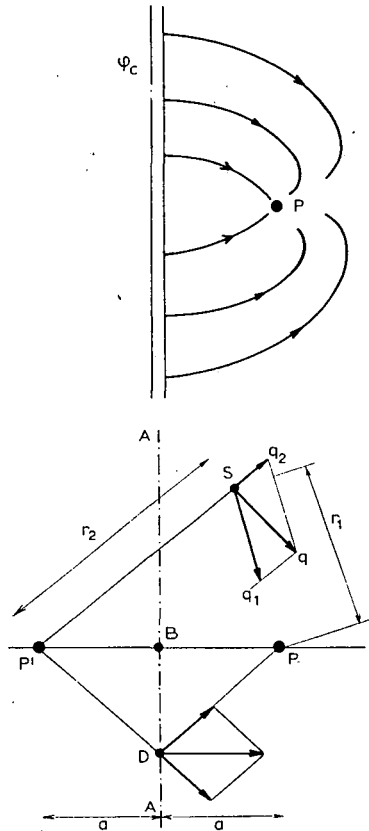

- Potential ψ_c at infinite distance from the well in all directions (so that the aquifer would be at rest if the well were not exploited)

- No recharge ($n = 0$).

The system can best be studied by replacing the canal with an imaginary well P' , sited symmetrically to well P about the axis of the canal, and into which the same quantity Q_0 is injected as is extracted from well P . (Negative well: extraction $- Q_0$). The study is only concerned with the half aquifer containing the well P ; the flow pattern of the other half is fictitious. The solution is found by superposition of the influences of the two wells.

The figure shows why the influence of the second well is equivalent to that of the canal. All along the canal axis the velocity is perpendicular to it, as is shown for point D . A zero velocity component along the canal corresponds to the condition of constant potential in the canal.

The potential at an arbitrary point S is

$$\varphi = \varphi_c - \frac{Q_0}{2\pi kD} \ln \frac{r_2}{r_1}$$

In particular the potential in the well (radius r_0) is

$$\varphi = \varphi_c - \frac{Q_0}{2\pi kD} \ln \frac{2a}{r_0}$$

(if r_0 is neglected in comparison with $2a$).

The flow vector q at S is the vectorial sum of q_1 and q_2 , whose magnitudes are respectively,

$$|q_1| = \frac{Q_0}{2\pi r_1}; \quad |q_2| = \frac{Q_0}{2\pi r_2}$$

In particular, the flow vector in B is

$$|q_B| = \frac{Q_0}{\pi a}$$

As is implied in these results, the flow pattern covers the whole aquifer to infinite distance from the well.

These formulas are derived from superposition of the influences of the wells P and P' . Only the determination of the integration constant requires comment. The potential at any point S , resulting from the extraction from well P is

$$\varphi_1 = \frac{Q_0}{2\pi kD} \ln \frac{r_1}{c_1}$$

and from the replenishment to well P'

$$\varphi_2 = - \frac{Q_0}{2\pi kD} \ln \frac{r_2}{c_2}$$

where c_1 and c_2 are integration constants. Under the combined influence of the two wells the potential is the sum:

$$\varphi = - \frac{Q_0}{2\pi kD} \ln \frac{r_2}{r_1} + c$$

where $\varphi = \varphi_1 + \varphi_2$, and $c = (Q_0/2\pi kD) \ln (c_2/c_1)$. Along the axis of the canal $r_1 = r_2$, hence $\ln (r_2/r_1) = \ln 1 = 0$, and $\varphi = c = \varphi_c$. This shows that the combination of the two wells defines along the axis of the canal the same condition

$\varphi = \varphi_c$ as was imposed by the canal itself. Moreover, at infinite distance from the well, where r_2/r_1 tends to 1 as well, φ is also equal to φ_c .

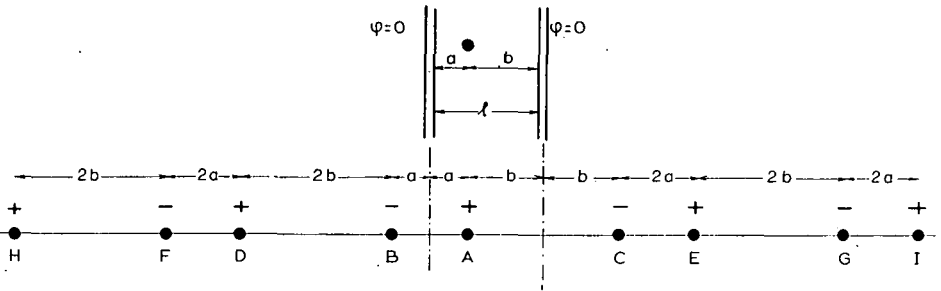

Fig: 18

2.3.4 Well between two canals

Figure 18. – A well with a discharge Q_0 is sited between two infinitely long parallel canals, where $\varphi = 0$. The problem is the same as the previous one, with the addition of a second canal. The method of solution is similar. The flow pattern can be found by replacing the two canals by an infinite series of positive and negative wells (positive for extraction; negative for replenishment), each having a capacity Q_0 , and sited as shown in the figure. This series of wells is characterized by

- geometrical symmetry about either of the canal axes,
- opposite signs to the left and right of either canal.

The series of wells is equivalent to the canals, since each pair of a positive and negative well, sited symmetrically about any of the axes, gives a flow vector perpendicular to that axis in any of its points. Hence the flow vector resulting from the infinite series of wells is also perpendicular to either of the axes.

Only the flow pattern in that part of the aquifer between the canals will be considered. The potential at any point is the sum of the influences of an infinite number of wells. As was shown in the previous sections, it is not possible to determine the influence of each well separately, because of the infinite value of φ , either in the well itself, or at infinite distance. However, the influence of each pair of a positive and a negative well is finite. Thus, the summation of the influences of the wells should be done in pairs. The succession can be chosen in various ways. When taking, for instance, in schematic notation

$$(A + B) + (C + D) + (E + F) + (G + H)$$

it is clear that the terms within brackets diminish regularly in absolute value and

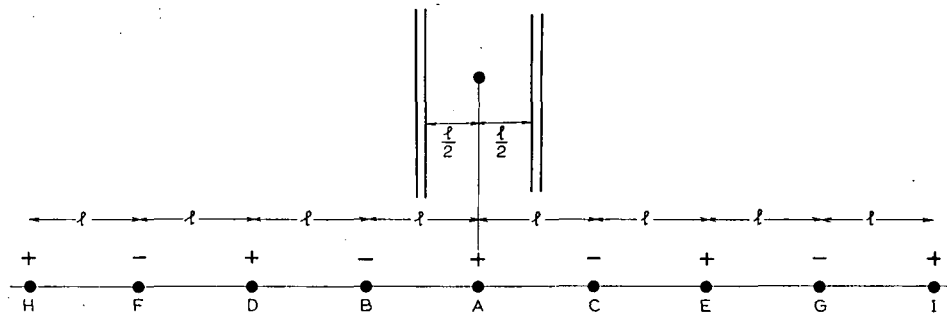

Fig. 19

eventually vanish, while their signs alternate. This is a mathematical criterion for the convergence of the series.

Similarly, the flow vector in any point is the vectorial sum of an infinite series of vector terms, each term resulting from a pair of wells. The convergence can be proven in the same way by considering the vertical and the horizontal components separately. Figure 19. - As an example the potential φ_0 at the well face can be calculated when the well is sited midway between the canals ($b = a = l/2$). When summing in the given succession

$$(A + B) + (C + D) + (E + F) + (G + H)$$

the result is found to be

$$\varphi = \frac{Q_0}{2\pi kD} \ln \frac{\pi r_0}{2l}$$

Using the formulas of the previous section the result can be written

$$\begin{aligned} \varphi &= \frac{Q_0}{2\pi kD} \left(\ln \frac{r_0}{l} + \ln \frac{2l}{l} + \ln \frac{2l}{3l} + \ln \frac{4l}{3l} \right) \\ &= \frac{Q_0}{2\pi kD} \ln \frac{r_0}{l} \frac{2}{1} \frac{2}{3} \frac{4}{3} \frac{4}{5} \frac{6}{5} \frac{6}{7} \frac{8}{7} = \frac{Q_0}{2\pi kD} \ln \left(\frac{r_0}{l} \frac{\pi}{2} \right) \end{aligned}$$

using a well-known expression for $\pi/2$ in the form of an infinite product (Wallis's formula).

2.3.5 Well between a canal and an impermeable boundary

Figure 20. - The next problem differs from the previous one in that the canal on the right is replaced by an impermeable boundary. A well P with a discharge Q_0 is sited

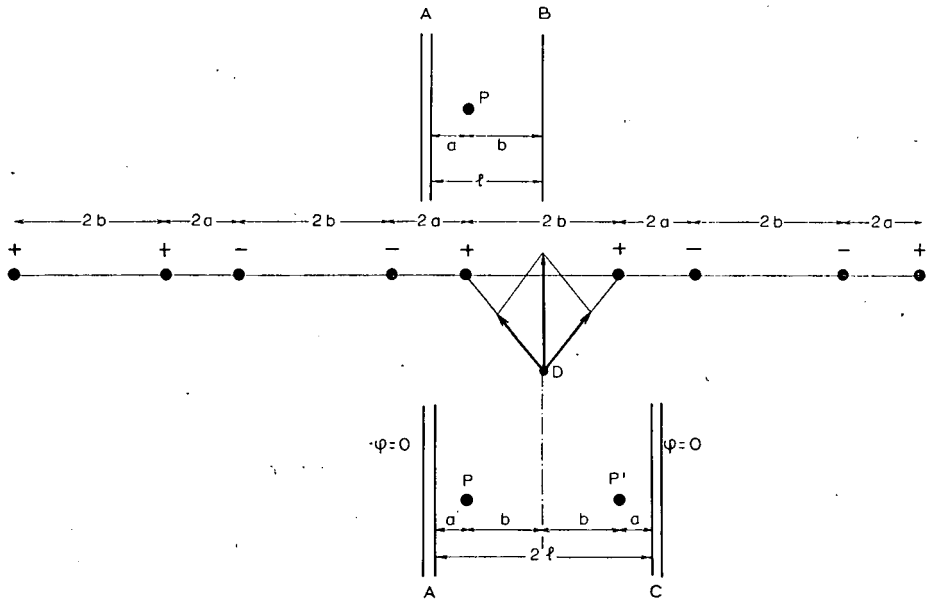

Fig. 20

between an infinitely long straight canal A , ($\varphi = 0$), and an impermeable boundary B , parallel to the canal.

The flow pattern can be determined when the canal and the impermeable boundary together are replaced by a series of wells, characterized by

- geometric symmetry about both the axes A and B ,
- difference in sign at either side of the canal axis A ; identical signs relative to the line of the impermeable boundary B .

The last condition results from the consideration that each pair of wells, symmetrical to the axis B , both in position and in sign, causes a flow vector along that axis at any of its points D , as shown in the figure. Thus the flow vector defined by the infinite series of wells is also directed along that axis, which is the condition for an impermeable boundary.

Because of the perfect symmetry about the axis B , the flow pattern in the zone between the axes B and A can also be described as one half of the symmetrical flow system determined by two wells P and P' (both extracting at a rate Q_0), sited in a zone bounded by two canals A and C ($\varphi = 0$ in both). This arrangement is indicated in the lower part of the figure.

In particular, if in the upper part of the figure the well P is sited against the impermeable wall, ($b = 0$, $a = l$), this means that in the lower part of the figure the wells P

and P' coincide, so as to form one well extracting at a rate $2Q_0$. According to the previous section the potential in this well is

$$\varphi_0 = \frac{Q_0}{\pi k D} \ln \frac{\pi r_0}{4l}$$

2.3.6 Well near a canal in uniform flow

(See also Section 2.4.4, where the same problem is examined in more detail, using the theory of complex numbers).

Figure 21. – The model is defined by an aquifer with constant D , bounded on the left by an infinitely long straight canal, and extending infinitely to the right. A well is sited at distance a from the canal. As to the flow system, if no water were extracted from the well, the aquifer would flow at a uniform rate q_0 at right angles to the canal, where $\varphi = 0$. The aquifer receives no recharge. The problem is to determine the flow pattern when water is extracted from the well at a rate Q_0 after steady-state conditions have been reached.

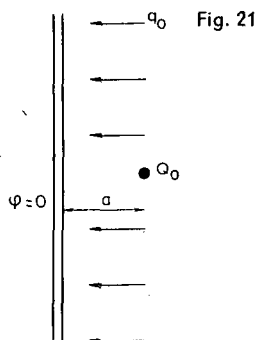

The definition of the flow system raises difficulties. Since the aquifer extends to infinity on the right, the potential would rise to infinite heights. In the case of a confined or partly confined aquifer, the top layer would be uplifted by the pressure of the water; in the case of a phreatic aquifer the thickness of the water body would become infinitely great, and D would no longer be approximately constant.

There are two ways to handle the problem. The first is to assume a sloping base of the aquifer. This model will be studied in the next section. The second is to consider only a strip of an aquifer bounded on the right by a second canal ($\varphi = 0$), parallel to the first, at a distance l , great compared with a (as will be shown the condition is $\frac{l}{2} \gg a$). A uniform recharge is assumed, whose influence in the narrow strip,

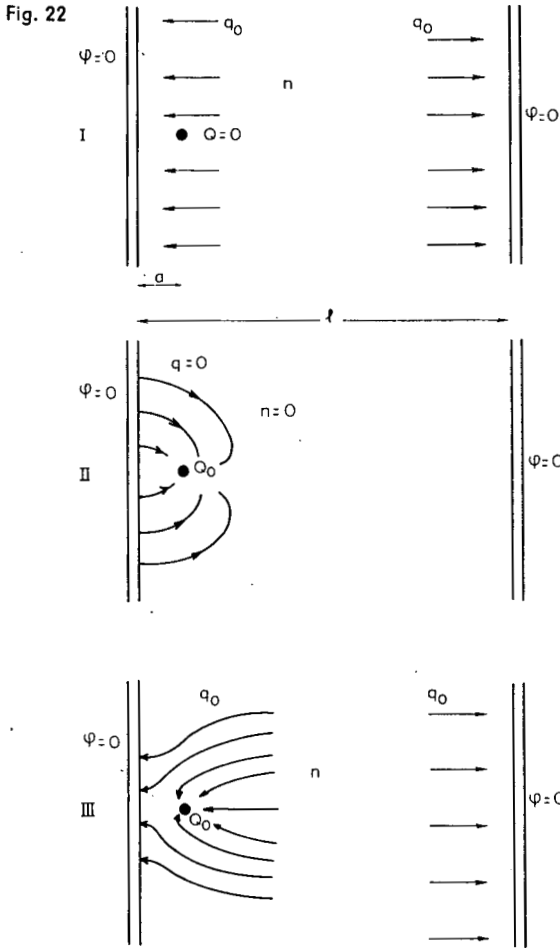

however, is negligible. This scheme will be examined next. At first sight the assumptions made may seem complicated; they have been deliberately chosen as a preparation for the study of related problems, dealt with in following chapters (Sections 3.4 and 6.2.6).

Figure 22. – The flow system, III, described above, will be considered as the sum of two elementary systems, I and II, defined by

System I:

- Recharge n .
- No extraction from the well.
- $\varphi = 0$ in both canals.

System II:

- $n = 0$
- Extraction Q_0 from the well.
- $\varphi = 0$ in both canals.

It follows that System III is defined by:

- Recharge n .
- Extraction Q_0 from the well.
- $\varphi = 0$ in both canals.

System I was studied in Section 2.2.1, where the following formulas were established

$$\varphi = \frac{n}{2kD} x(l - x); \quad q = n \left(\frac{l}{2} - x \right).$$

In the following, only a narrow strip near the canal on the left will be considered, determined by $x \ll \frac{l}{2}$. Since the well is in this strip, also $a \ll \frac{l}{2}$. Under this assumption the above formulas reduce to

$$\varphi = \frac{nl}{2kD} x = \frac{q_0}{kD} x; \quad q = n \frac{l}{2} = q_0$$

which are the formulas of uniform flow q_0 towards the canal, without supply n .

Figure 23. - System II has been studied in Section 2.3.4. (Well between two canals).

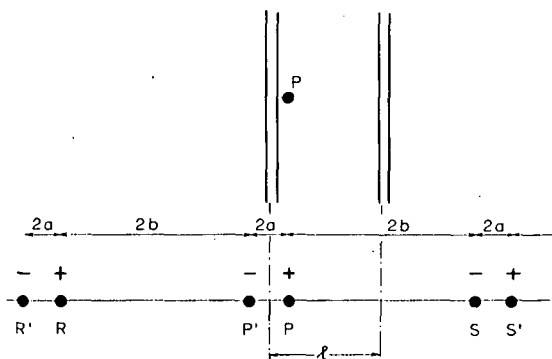

Fig. 23

The two canals can be replaced by an infinite series of wells, as indicated in the figure. If only a narrow strip near the left-hand canal is considered, the wells P and P' suffice, the influence of the other wells being negligible. This reduces the problem to that of Section 2.3.3 (Well near a canal).

The distance $2b$ is great compared with $2a$. Moreover, the wells R and R' , near to each other and with opposite sign, almost counterbalance each other. The same applies to the wells S and S' .

From these considerations the potential φ as well as the vector q can be determined at each point in the strip for both Systems I and II, and by summation for System III. Reference is made to Section 2.4.4 where the results are given.

2.3.7 Sloping base

Figure 24. – In this section, by way of exception, an aquifer will be examined, resting on a base that dips slightly along the x axis. The aquifer receives no recharge. If D is exactly or approximately constant, the fundamental hydraulic laws are the same as in the case of a horizontal base:

– The law of linear resistance:

$$(1) \quad q_x = -kD \frac{\partial \varphi}{\partial x}; \quad q_y = -kD \frac{\partial \varphi}{\partial y}$$

– The law of continuity:

$$(2) \quad \frac{\partial q_x}{\partial x} + \frac{\partial q_y}{\partial y} = 0$$

In a horizontal aquifer, φ is bound to certain limits. If the aquifer is confined or partly confined, φ should not fall below a certain value in order to keep the aquifer full of water, nor rise above another value, to avoid uplifting of the top layer by too high a pressure. If the aquifer is phreatic, the limits are much narrower: to keep D approximately constant, its deviations from the average value should be negligible.

The same conditions apply to a sloping aquifer, where they limit the deviations of φ , not from a constant value φ_0 , but from a variable quantity $\varphi_0 + \gamma\alpha x$. In other

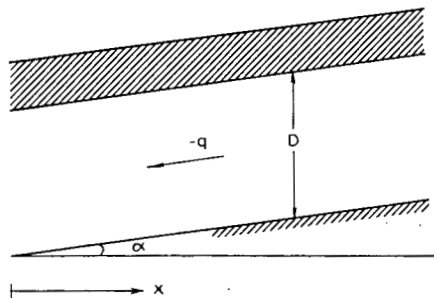

Fig. 24

words, while flow systems with a horizontal base are described as deviations from a state of rest, those with a sloping base are described as deviations from a system defined by

$$\begin{aligned}\varphi &= \varphi_0 + \gamma\alpha x \\ q_x &= -kD\gamma\alpha = q_0 \\ q_y &= 0\end{aligned}$$

Since the differential equations are the same in both cases, many hydraulic phenomena are the same. For instance, extraction at a constant rate from a well in a horizontal aquifer, starting from a state of rest, would never lead to steady flow. In the same way, in the case of a sloping base, starting from a state, defined by

$$\varphi = \varphi_0 + \gamma\alpha x, \quad q_x = q_0, \quad q_y = 0$$

extraction from a well at a constant rate Q_0 would not lead to steady flow either. If, however, the aquifer were limited by a horizontal, straight, infinitely long canal along the y axis, where $\varphi = \varphi_0$, constant extraction from a well, sited on either the upstream or the downstream side of the canal, would result in a steady flow system. The formulas would be the same as in the previous section. This is the other way of representing physically the system of a well near a canal in uniform flow.

2.3.8 Approximation for series of wells

In this section an approximative method will be given for calculating the influence of series of wells. Such an approximation may be used as a first approach to a problem, to be checked afterwards by precise calculations. It may also be considered as a final evaluation if the transmissivity or the recharge are not well known, or if any other unknown factor reduces the value of the exact solution. Lack of precise data is frequent in groundwater engineering.

Figure 25. - The drainage of a phreatic or partly confined aquifer with constant D may be effectuated by a grid of wells extending in all directions to infinity. The wells are sited in parallel series at interdistance a ; the spacing of the wells within the series is b , where b is assumed considerably smaller than a .

The flow system is defined by a uniform recharge n , and an extraction Q_0 from each well. Steady flow requires that

$$Q_0 = nab$$

A series of wells shows a certain analogy with a canal, in that in both cases the potential is lowered along a line, which is the axis of either the well series or the canal. Therefore, first the well series will be replaced by canals, from which a quantity q_0 is extracted per unit length, so that

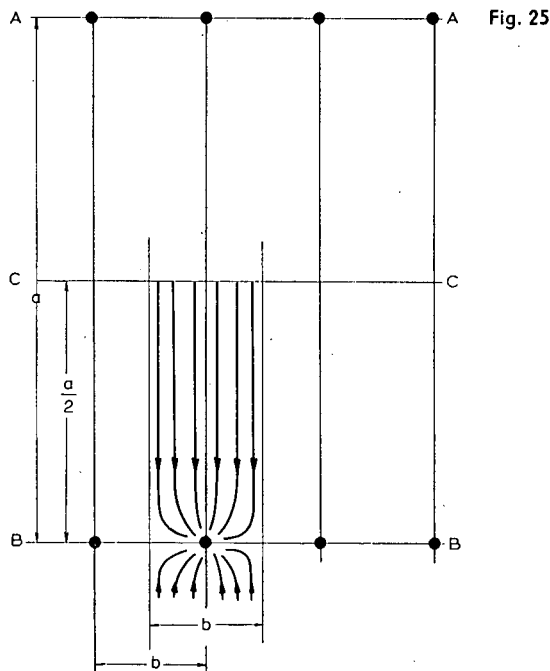

$$q_0 = na$$

The highest potential exists in the symmetry axis CC ; the lowest in the canal. The difference $\Delta\varphi_1$, according to Section 2.2.1, is

$$\Delta\varphi_1 = \frac{na^2}{8kD}$$

Actually the extraction takes place locally from the wells, instead of uniformly from the canal. The first consequence is that the potential in the line CC is not constant. Deviations from the average value, however, will be neglected, since a is assumed much greater than b . Thus the potential in the line CC is considered as a constant φ_c . The second consequence is that φ_0 in the well is lower than the hypothetical potential in the canal. The losses of energy are concentrated in the vicinity of the well, where the flow is radial. For radial flow, the loss of potential between a radius r and the radius of the well r_0 can be calculated according to Section 2.3.1. In absolute value

$$\Delta\varphi_2 = \frac{Q_0}{2\pi kD} \ln \frac{r}{r_0}$$

The approximation is that $\Delta\varphi_1$ and $\Delta\varphi_2$ are added for finding the difference in potential $\varphi_c - \varphi_0$ between the line CC and the face of the well

$$\varphi_c - \varphi_0 = \frac{na^2}{8kD} + \frac{Q_0}{2\pi kD} \ln \frac{r}{r_0}$$

taking for r such a value that the circumference of a circle with radius r is equal to the front through which the water flows towards the well from both sides together:

$$2\pi r = 2b$$

Using $Q_0 = nab$ the result may be written in the form

$$\varphi_c - \varphi_0 = \Delta\varphi_1 + \Delta\varphi_2 = \frac{na^2}{8kD} + \frac{nab}{2\pi kD} \ln \frac{b}{\pi r_0}$$

Some justification of this choice can be found in the following consideration. $\Delta\varphi_1$ represents the loss of energy in parallel flow over a length $1/2a$; $\Delta\varphi_2$ the loss in radial flow over a length $r = b/\pi$, which is about $1/3b$. Thus the total flow length assumed amounts to $1/2a + 1/3b$. Actually all streamlines have different lengths; the shortest measures $1/2a$; the longest $1/2a + 1/2b$. Between these values $1/2a + 1/3b$ appears as a fair average.

2.4 SOLUTIONS IN TERMS OF COMPLEX NUMBERS

This section deals with some of the most important applications of the classical theory of complex numbers to groundwater flow. At the outset some general remarks should be made.

1. Due to its historical development, the theory of complex numbers is generally presented in an unsatisfactory way, with square roots of negative numbers as a basic element. A better theoretical development can be given, leading to the same results, but on the one hand this would require a profound discussion of the fundamentals of algebra, and on the other hand would lead to more general conclusions than potential flow theory only. It therefore will not be given here; the theory will be presented in its classical form.

2. In a treatise on vector algebra it is desirable to make a distinction in notation between symbols representing numbers and vectors (here complex numbers). In this publication the theory of complex numbers occupies only a small space. Thus the choice of the symbols has been determined mainly by the requirements of the other chapters, and no difference in notation between numbers and vectors could be made without complicating the orthography of the whole.

3. If $\varphi + i\psi$ is an analytic function of $x + iy$, the relation can be represented graphically. If, as will be done in this section, lines of equal φ and ψ are drawn in a graph where x and y are plotted on the axes, the reasoning can be based on either the function

$$\varphi + i\psi = F(x + iy)$$

or the inversion function

$$x + iy = G(\varphi + i\psi)$$

The second representation is preferable. The first, however, will be chosen for traditional reasons and also because the function F appears anyhow, and alternative use of the functions F and G might create confusion.

4. The formulas will be written in dimensionless form. For an explanation of this point reference is made to Section 1.3.5.

2.4.1 Fundamentals

The following theory is valid for $n = 0$ (and constant D). Under these assumptions the differential equations read:

- The law of linear resistance

$$q_x = -kD \frac{\partial \varphi}{\partial x}; \quad q_y = -kD \frac{\partial \varphi}{\partial y}$$

- The law of continuity

$$\frac{\partial q_x}{\partial x} + \frac{\partial q_y}{\partial y} = 0$$

To simplify the formulas, it is customary in this theory to write φ instead of $kD\varphi$. Thus, if the result of a calculation reads $\varphi = c$, this should be read $kD\varphi = c$ or $\varphi = c/kD$. In other words, the values of φ obtained as results must be divided by kD . The equations then reduce to

$$(1) \quad q_x = -\frac{\partial \varphi}{\partial x}; \quad q_y = -\frac{\partial \varphi}{\partial y}$$

$$(2) \quad \frac{\partial q_x}{\partial x} + \frac{\partial q_y}{\partial y} = 0$$

These equations are satisfied by solutions of the following form

$$(3) \quad \phi = \varphi + i\psi = F(z) = F(x + iy)$$

$$(4) \quad q^* = q_x - iq_y = -F'(z) = -\frac{dF}{dz}$$

where F is an arbitrary analytical function of z . Equation (3) contains a variable ψ , which does not occur in the differential equations (1) and (2). Its physical meaning will be explained below. The solution, as defined by (3) and (4), satisfies in effect a second set of differential equations, similar to (1) and (2), but with ψ instead of φ as a variable. For physical reasons, however, Equations (3) and (4) will only be considered in relation to (1) and (2). From the same viewpoint a second solution, where in (3) ψ is replaced by $-\psi$ is ignored. Although mathematically the solution is independent of the first, it does not yield new physical results.

The quantity q^* ($= q_x - iq_y$) must be introduced, since it cannot be written as an analytic function of \dot{q} ($= q_x + iq_y$). In particular, no complex number a can be found such that $q^* = aq$. Graphically q^* is the vector symmetrical to q with respect to the real axis.

Proof that Equations (3) and (4) satisfy (1) and (2):

Differentiating (3) with respect to x , and multiplying by -1

$$(5) \quad -\frac{\partial \varphi}{\partial x} - i \frac{\partial \psi}{\partial x} = -F'$$

Differentiating (3) with respect to y , and multiplying by i :

$$(6) \quad -\frac{\partial \psi}{\partial y} + i \frac{\partial \varphi}{\partial y} = -F'$$

Equation (4) reads

$$(4) \quad +q_x - iq_y = -F'$$

Since the right-hand members of (5), (6) and (4) are equal, the left-hand members are equal for their real and imaginary parts separately. Hence

$$q_x = -\frac{\partial \varphi}{\partial x} \text{ and } q_y = -\frac{\partial \varphi}{\partial y}$$

which corresponds to (1).

Differentiating (4) with respect to x :

$$(7) \quad \frac{\partial q_x}{\partial x} - i \frac{\partial q_y}{\partial x} = -F''$$

Differentiating (4) with respect to y , and multiplying by i :

$$(8) \quad i \frac{\partial q_x}{\partial y} + \frac{\partial q_y}{\partial y} = F''$$

Adding (7) and (8), and equating the real parts:

$$\frac{\partial q_x}{\partial x} + \frac{\partial q_y}{\partial y} = 0$$

which corresponds to (2).

The given solution defines ϕ and ψ for each point of the field. Thus lines of equal ϕ and equal ψ can be drawn. It is customary to space them by equal intervals $\Delta\phi = \Delta\psi$. It can then be shown that the elementary quadrilaterals enclosed by these lines are squares. Since the lines of equal ψ are in all points perpendicular to the equal potential lines, they are stream lines. The water flows in the direction of decreasing ϕ .

The area around a point z_1 can be represented by $z_1 + \Delta z$, where Δz is a variable vector. Using this notation, the functional relationship can be written as a series (Theorem of Taylor)

$$\phi = F(z_1) + F'(z_1)\Delta z + F''(z_1)\frac{(\Delta z)^2}{2} \dots$$

For a small area around z_1 , the first terms suffice:

$$\phi = F(z_1) + F'(z_1)\Delta z$$

Writing $F(z_1) = \phi_1$ and $\phi - \phi_1 = \Delta\phi$

$$\Delta\phi = F'(z_1)\Delta z.$$

In the series all coefficients $F(z_1)$, $F'(z_1)$, $F''(z_1)$ are complex numbers. Writing in the last expression $F'(z_1)$ as a complex number c

$$\Delta\phi = c\Delta z$$

or

$$\frac{1}{c}(\Delta\phi + i\Delta\psi) = \Delta z$$

Displacement along an equipotential line ($\Delta\phi = 0$) over an interval $\Delta\psi$ corresponds to

$$\Delta z_1 = \frac{1}{c} i\Delta\psi$$

Displacement along a line of constant ψ ($\Delta\psi = 0$) over an interval $\Delta\phi$ corresponds to

$$\Delta z_2 = \frac{1}{c} \Delta \phi$$

Since $\Delta \psi = \Delta \phi$ as a convention, the vectors Δz_1 and Δz_2 have equal length and are perpendicular to each other.

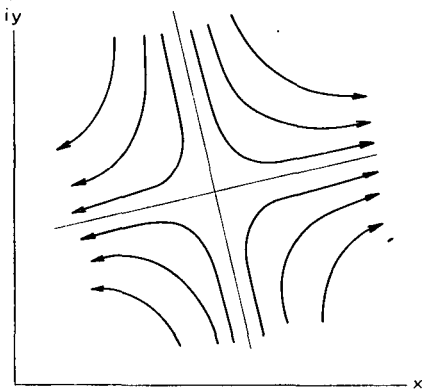

Fig. 26

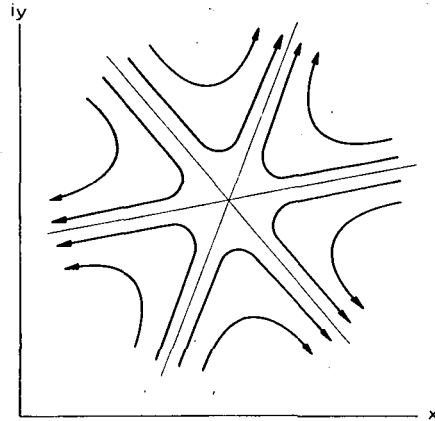

Fig. 27

Figure 26. - At certain points $F'(z_1)$ may be zero. It follows from $q^* = -F'(z)$ that at these points q^* , and therefore the flow vector q , is zero. Such points are called stagnation points. The flow net shows a particularity: the figure represents the flow-lines; the equipotential lines, not shown, are perpendicular to them.

For a small area around such a point the functional relationship reduces to

$$\phi = F(z_1) + F''(z_1) \frac{(\Delta z)^2}{2!}$$

or

$$\Delta \phi = \frac{F''(z_1)}{2!} (\Delta z)^2$$

or

$$\Delta \phi = c(\Delta z)^2$$

where c is a complex number. This relationship, according to classical theory, corresponds to the given figure.

Figure 27. - In the following sections yet another type of stagnation point will be studied, where $F'(z_1) = F''(z_1) = 0$. The flow pattern is indicated in the figure. The straight lines intersect at 60° .

The proof is similar. The functional relationship for values near z_1 reduces to

$$\Delta\phi = c(\Delta z)^3$$

where c is a complex number.

2.4.2 Well in an infinite aquifer

In this and the following sections the problem will be defined by a given function $\phi = F(z)$. The characteristics of the flow system are to be derived from this formula. First the following function will be examined

$$(1) \quad \phi = \varphi + i\psi = F(z) = \ln z$$

$$(2) \quad q^* = q_x - iq_y = -F'(z) = -\frac{1}{z}$$

Figure 28. - These equations describe the flow around a well sited at the origin. With $z = re^{i\theta}$, the formula for the potential can be written as

$$\varphi = \ln r$$

Upon substitution of $re^{i\theta}$ for z , Equation (1) becomes

$$\varphi + i\psi = \ln z = \ln r + i\theta$$

Equating the real parts

$$\varphi = \ln r$$

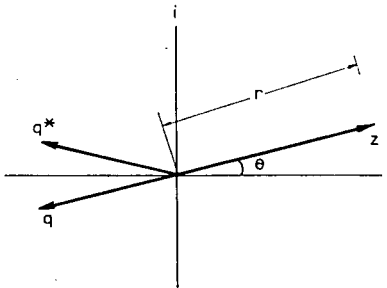

Fig. 28

Since φ depends on r only, and not on θ , the flow is radial. At the face of the well, ($r = r_0$), $\varphi = \ln r_0$, which is a finite value. For $r \rightarrow \infty$, $\varphi \rightarrow \infty$, in agreement with Section 2.3.1.

The flow vector can be written as

$$q = -\frac{1}{r} e^{i\theta}$$

According to (2)

$$q^* = q_x - iq_y = -\frac{1}{z} = -\frac{1}{r} e^{-i\theta}$$

Thus

$$q = q_x + iq_y = -\frac{1}{z} e^{i\theta}$$

The vector q is directed along z , but in the opposite direction, which indicates radial flow towards the origin. Its absolute value $|q| = 1/r$. Thus the quantity flowing through a cylinder with radius r is

$$Q = 2\pi,$$

a constant, which confirms the basic assumption $n = 0$. The quantity extracted from the well has the same value

$$Q_0 = 2\pi$$

2.4.3 Well near a canal

The function is

$$(1) \quad \phi = F(z) = \ln(z - a) - \ln(z + a) = \ln \frac{z - a}{z + a}$$

$$(2) \quad q^* = -F'(z) = -\left(\frac{1}{z - a} - \frac{1}{z + a}\right)$$

where a is a complex number.

Figure 29. - It can readily be seen that if $\phi = \ln z$ represents the flow towards a well at the origin, $\phi = \ln(z - a)$ represents the flow towards a well at the point indicated by the vector a .

The figure shows that the vector $z - a$ defines the position of a point S with respect to the well P in the same way as does the vector z with respect to a well at the origin.

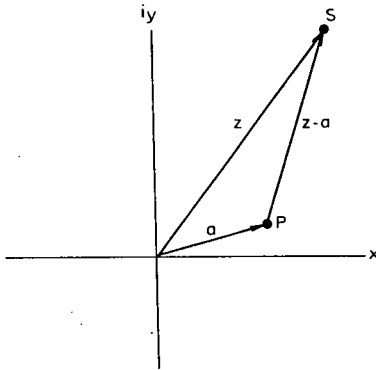

Fig. 29

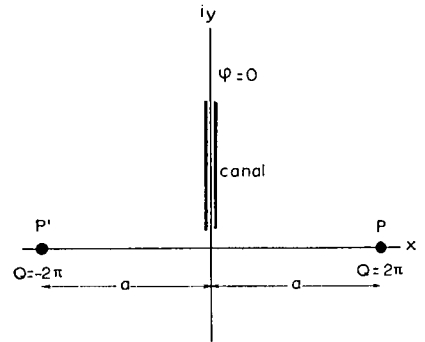

Fig. 30

Figure 30. – Thus the formula

$$\phi = \ln(z - a) - \ln(z + a)$$

corresponds to the combination of two wells P and P' , sited at $+a$ and $-a$, respectively, extracting and replenishing respectively, quantities 2π . This combination is known from Section 2.3.3. It is equivalent to the combination of the well P and a canal along the axis of symmetry between the two wells. If a real positive value is chosen for a , the well P is on the positive real axis and the canal along the imaginary axis.

Figure 31. – The formulas (1) and (2) imply the following propositions:

1. The canal is an equipotential line with $\phi = 0$.
2. At infinite distance from the well P in all directions, $\phi = 0$ as well.
3. At an arbitrary point S of the aquifer the potential is

$$\phi = \ln(r_1/r_2)$$

4. At the face of the well ($r = r_0$)

$$\phi = \ln(r_0/2a)$$

5. At an arbitrary point S of the aquifer the flow vector is

$$q = -\frac{2a}{r_1 r_2} e^{i(\theta_1 + \theta_2)}$$

$$|q| = 2a/r_1 r_2$$

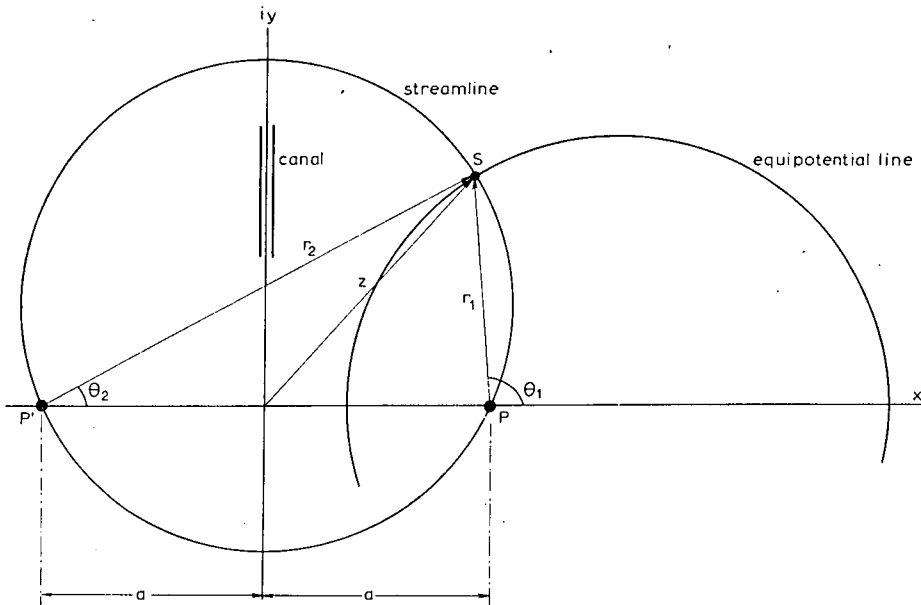

Fig. 31

6. At the origin of the coordinate system

$$|q| = 2/a$$

7. Streamlines and equipotential lines are circles.

Proof of these propositions. - The figure shows that

$$z - a = r_1 e^{i\theta_1}$$

$$z + a = r_2 e^{i\theta_2}$$

Thus

$$\phi = \ln \frac{z - a}{z + a} = \ln \frac{r_1}{r_2} + i(\theta_1 - \theta_2)$$

Equating this to $\phi + i\psi$:

$$\phi = \ln(r_1/r_2) \text{ (proposition 3), and } \psi = \theta_1 - \theta_2$$

Lines of constant ϕ (equipotential lines) are lines of constant r_1/r_2 ; lines of constant ψ (streamlines), are lines of constant $\theta_1 - \theta_2$. According to well-known geometric properties both are circles (Proposition 7).

For any point of the canal, $r_1 = r_2$, and $\varphi = \ln(r_1/r_2) = \ln 1 = 0$ (Proposition 1).
 For any point at infinite distance from both wells the ratio r_1/r_2 tends to 1 as well, and φ tends to zero (Proposition 2).

At the face of the well $r_1 = r_0$ and $r_2 = 2a$, neglecting r_0 in comparison with $2a$. Thus $\varphi = \ln(r_0/2a)$ (Proposition 4).

The vector q^* is defined by

$$q^* = - \left(\frac{1}{z-a} - \frac{1}{z+a} \right) = - \frac{2a}{(z-a)(z+a)}$$

Substituting

$$z-a = r_1 e^{i\theta_1} \text{ and } z+a = r_2 e^{i\theta_2}$$

$$q^* = - \frac{2a}{r_1 r_2} e^{-i(\theta_1 + \theta_2)}$$

or

$$q = - \frac{2a}{r_1 r_2} e^{i(\theta_1 + \theta_2)}$$

This formula gives the absolute value of the vector

$$|q| = 2a/r_1 r_2$$

as well as its direction: an angle $\theta_1 + \theta_2$ with the negative real axis (Proposition 5).

At the origin of the axes, $r_1 = r_2 = a$, hence

$$|q| = \frac{2a}{a^2} = \frac{2}{a}$$

(Proposition 6).

The results obtained must be transformed, taking into account some of the premisses made at the outset. An example will be given for the formulas of φ and q at an arbitrary point (Propositions 3 and 6)

$$\varphi = \ln(r_1/r_2)$$

$$q = - \frac{2a}{r_1 r_2} e^{i(\theta_1 + \theta_2)}$$

Firstly it should be remembered that φ stands for $kD\varphi$, thus the first formula reads

$$\varphi = \frac{1}{kD} \ln \frac{r_1}{r_2}$$

Secondly the extraction rate from the wells, in absolute value, was 2π . For an arbitrary extraction Q_0 instead of 2π all values of φ and q must be multiplied by $Q_0/2\pi$, thus

$$\varphi = \frac{Q_0}{2\pi kD} \ln \frac{r_1}{r_2}$$

$$q = - \frac{aQ_0}{\pi r_1 r_2} e^{i(\theta_1 + \theta_2)}$$

The expression for φ corresponds with the result of Section 2.3.3.

Finally this example can be used to show the formation of dimensionless plots in a scheme on which the theory of complex numbers has been applied (see Section 1.3.5). The scheme is defined by three constants, kD , a and Q_0 . Using these constants, dimensionless plots can be formed with the variables φ , q (q_1 or q_2) and r (r_1 or r_2).

$$\frac{kD}{Q_0} \varphi; \quad \frac{a}{Q_0} q; \quad \frac{r}{a}$$

The variables used in the general theory were

$$kD\varphi; \quad q; \quad r$$

since only kD occurs in all problems of this kind; a and Q_0 are proper to the present system only.

2.4.4 Well near a canal in a uniform flow

The function is

$$(1) \quad \phi = F(z) = \ln \frac{z-a}{z+a} + q_0 z$$

$$(2) \quad q^* = -F'(z) = -\left(\frac{1}{z-a} - \frac{1}{z+a}\right) - q_0$$

The first term of these expressions corresponds to the flow system examined in the previous section. Upon it the system

$$\phi = q_0 z$$

has been superposed, which corresponds to

$$\varphi = q_0 x; \quad q = -q_0$$

representing uniform flow at a rate q_0 towards the canal and perpendicular to it.

Figure 32. - The problem corresponds to that of Section 2.3.6. The model is defined

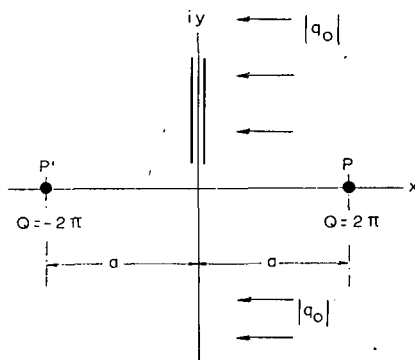

Fig. 32

by a canal, running along the imaginary axis, and a well P on the positive real axis, at a distance a from the canal. The aquifer extends to infinity to the right. The flow system is defined by

- $\varphi = 0$ in the canal.
- Extraction from the well at a rate 2π .
- Uniform flow at a rate q_0 in the direction of the negative real axis, if no water were extracted from the well.

As in the previous section the canal will be replaced by a negative well P' , sited symmetrically to P with respect to the canal, and replenishing at a rate 2π . The physical restrictions of this flow system are the same as in Section 2.3.6. They are subject to the considerations given there.

The values of φ and q are given by Eqs. (1) and (2),

$$\varphi = \ln \frac{r_1}{r_2} + q_0 x$$

$$q = - \frac{2a}{r_1 r_2} e^{i(\theta_1 + \theta_2)} - q_0$$

In the well

$$\varphi_0 = \ln \frac{r_0}{2a} + q_0 x$$

The derivation of these formulas does not require comment; the stagnation points, however, need a close analysis.

Figure 33. - Three cases can be distinguished.

Fig. 33

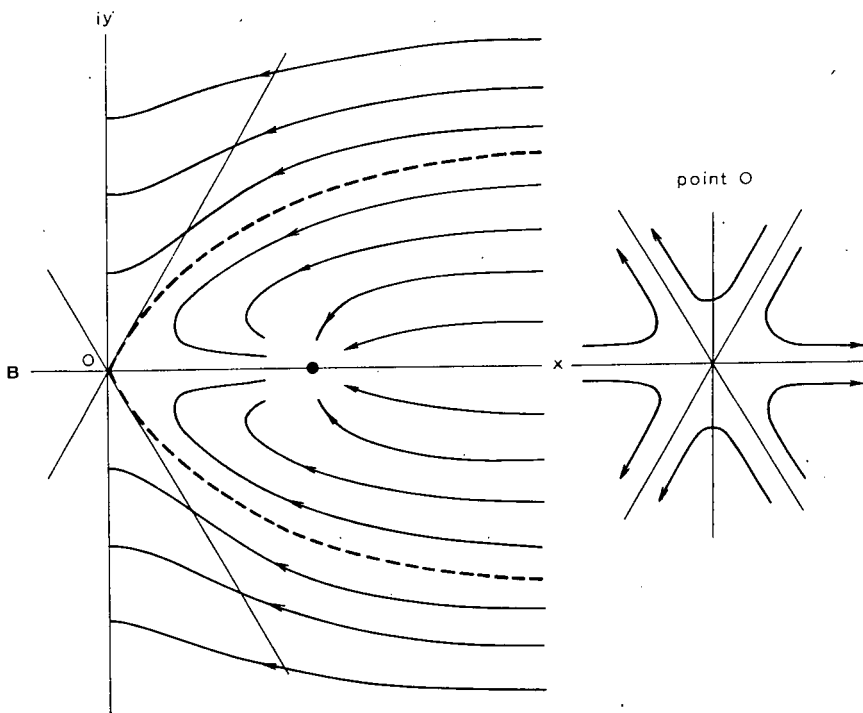
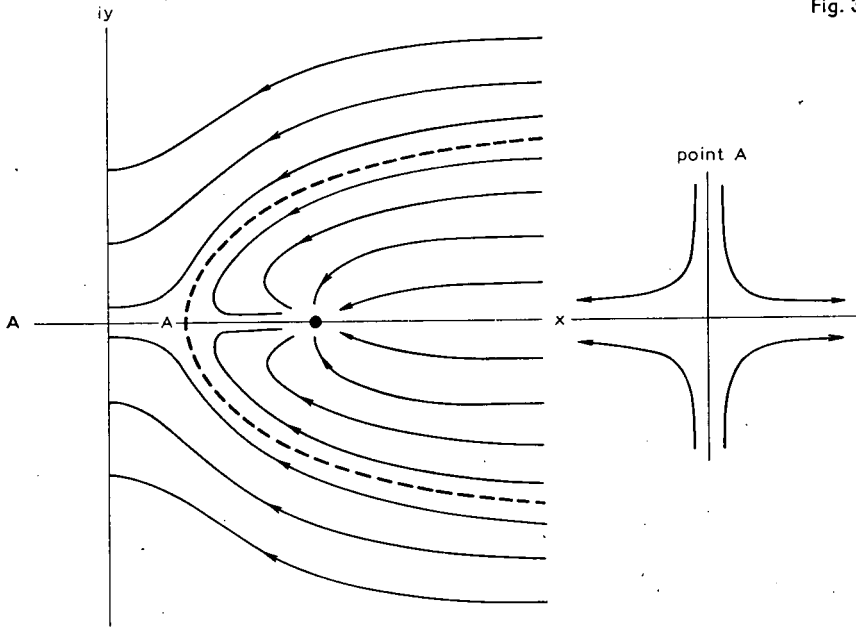
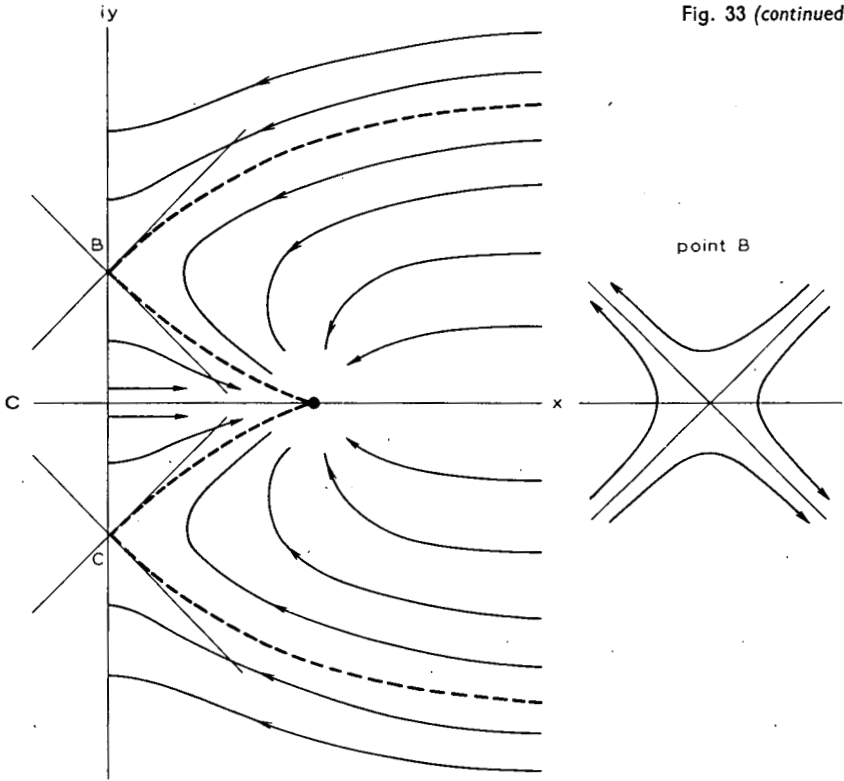

Fig. 33 (continued)



A. $q_0 > 2/a$. A single stagnation point of the type $\Delta\phi = c(\Delta z)^2$ exists at A , at a distance $\sqrt{a(a - 2/q_0)}$ from the origin. The dotted line divides the aquifer into two parts, one delivering into the well, the other into the canal. At a great distance to the right the two branches of the dotted line are parallel at a distance $2\pi/q_0$, so that the parallel flow q_0 over that breadth corresponds to the extraction rate 2π of the well.

B. $q_0 = 2/a$. A stagnation point of the type $\Delta\phi = c(\Delta z)^3$ exists at the origin of the coordinate axes. The division of the aquifer into two parts is the same as in the previous case, as is the distance between the branches of the dotted line at great distance to the right.

C. $q_0 < 2/a$. Two points of the type $\Delta\phi = c(\Delta z)^2$ exist at B and C on the canal border, at distance $\sqrt{-a(a - 2/q_0)}$ on either side of the origin. The dotted line divides the aquifer into three parts, characterized respectively by flow into the well from the right, into the well from the canal, and into the canal. The distance between the branches of the dotted line at great distance to the right is smaller than $2\pi/q_0$, because the flow between these branches constitutes only part of the supply into the well.

The function

$$(1) \phi = F(z) = \ln \frac{z-a}{z+a} + q_0 z$$

has the following derivatives:

$$F'(z) = \frac{2a}{z^2 - a^2} + q_0$$

$$F''(z) = -\frac{4az}{(z^2 - a^2)^2}$$

$$F'''(z) = 4a \frac{3z^2 + a^2}{(z^2 - a^2)^3}$$

The particularity $F'(z) = 0$ applies to the points z where

$$(2) z^2 = a(a - 2/q_0)$$

Case A. $a - \frac{2}{q_0} > 0$. - There are two real values of z :

$$z = \pm \sqrt{a(a - 2/q_0)}$$

corresponding to two points on the real axis at equal distances at either side of the canal. Since only that part of the aquifer to the right of the canal corresponds to the physical model, only the positive value is considered. For this value of z , different from zero, $F''(z) \neq 0$, thus the stagnation point is of the type $\Delta\phi = c(\Delta z)^2$.

Case B. $a - 2/q_0 = 0$. - According to (2), $z = 0$, which locates the stagnation point at the origin of the coördinate axes. For $z = 0$, also $F''(z) = 0$, but not $F'''(z)$. The point is therefore of the type $\Delta\phi = c(\Delta z)^3$.

Case C. $a - 2/q_0 < 0$. - According to (2) z^2 is negative, which corresponds to two complementary, imaginary values of z :

$$z = \pm i \sqrt{-a(a - 2/q_0)}$$

representing two stagnation points on the canal border at equal distances from the origin. Since $z \neq 0$, $F''(z) \neq 0$, and the points are of the type $\Delta\phi = c(\Delta z)^2$.

3. STEADY FLOW, VARIABLE D , GIVEN n

3.1. ANALOGY WITH SYSTEMS WITH CONSTANT D

The assumptions made in the title are the same as those of the previous chapter, except that D is variable instead of constant, which limits the studies to phreatic aquifers. To simplify the formulas, the level of reference R will in all problems be chosen at the base of the aquifer. The thickness D of the water body is then equal to the piezometric height h , which in turn is equal to φ/γ . With this convention the formulas for φ and q from the previous chapter can be repeated when $D\varphi$ is replaced by $\varphi^2/2\gamma$. Flow nets formed by streamlines and equipotential lines remain unchanged if the equipotential lines are drawn at equal intervals of $\varphi^2/2\gamma$ instead of φD . In particular in Section 2.4 (solutions in terms of complex numbers), φ , which stands for $kD\varphi$, must be replaced by φ^2 , standing for $\frac{k}{2\gamma}\varphi^2$. Thus the text of this chapter could be an almost exact repetition of that of the previous one, and the formulas would show a great resemblance. To avoid uninteresting repetition, only those problems which require discussion will be taken up again.

The flow system is determined by differential equations and boundary conditions. As to the latter, they are the same; in both cases they are expressed in terms of φ or q . But the differential equations are different.

– The law of linear resistance (to be written for the x direction only) reads for constant D :

$$q_x = -kD \frac{\partial \varphi}{\partial x}$$

or

$$q_x = -k \frac{\partial(D\varphi)}{\partial x}$$

For variable D , where $D = h = \varphi/\gamma$

$$q_x = -k \frac{\varphi}{\gamma} \frac{\partial\varphi}{\partial x}$$

or

$$q_x = -k \frac{\partial(\varphi^2/2\gamma)}{\partial x}$$

Thus $D\varphi$ has been replaced by $\varphi^2/2\gamma$.

– The law of continuity in both cases reads,

$$\frac{\partial q_x}{\partial x} + \frac{\partial q_y}{\partial y} = n$$

The meaning of this substitution can be illustrated by the following reasoning. In the formulas the values of φ^2 always appear as differences: $\varphi^2 - \varphi_1^2$, or $\varphi_1^2 - \varphi_2^2$. (This is due to the fact that in the differential equations φ only appears in the form of derivatives of φ^2 . Upon integration expressions in φ^2 are found, containing an integration constant, which is eliminated by subsequent subtraction of two equations of the same form). The difference of two squares, for instance $\varphi_1^2 - \varphi_2^2$ can be written $(\varphi_1 - \varphi_2)(\varphi_1 + \varphi_2)$, where $\varphi_1 + \varphi_2$ may be replaced by $2\gamma D$, if φ_1 and φ_2 are near the average value of γD , as was the assumption of the previous chapter. Thus $\varphi_1^2 - \varphi_2^2$ corresponds to $2\gamma D(\varphi_1 - \varphi_2)$, which means replacing $D\varphi_1$ by $\varphi_1^2/2\gamma$, and $D\varphi_2$ by $\varphi_2^2/2\gamma$.

3.2 SUPERPOSITION AND WATER RESOURCES

Figure 34. – The principle of superposition can be applied as in the previous section by summing the values of q and n , but the values of φ^2 should be added instead of those of φ . The same model may serve for the proof. System I represents the natural flow pattern, System II the change brought about by the extraction from a well, and System III the final flow pattern after the flow is steady again. The same conclusions can be drawn, subject however to the following remarks.

1. For the definition of the specific drawdown or the specific capacity of a well, the relationship between $\Delta\varphi^2$ and Q_0 should be taken as a basis, instead of that between $\Delta\varphi$ and Q_0 . The conclusions then remain the same.

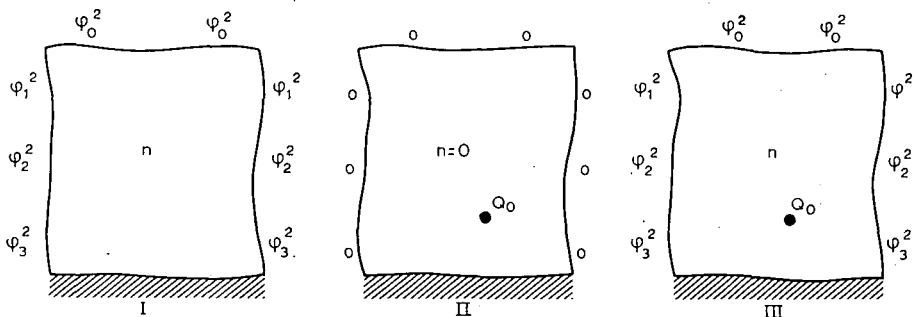

Fig. 34

2. In System II all values of φ^2 are negative; they do not correspond to real values of φ . This system has no physical meaning, but is merely a term in the mathematical operation of superposition. The negative values of φ^2 indicate that the values of φ^2 of System I must be reduced to obtain those of System III. Interpreted this way, the imaginary character of the system disappears. It should also be noted that if water had been pumped into the well instead of being extracted from it, the values of φ^2 in System II would have been positive, and the difficulty would not have arisen. This stresses the conclusion that the physical interpretation of this system is of minor importance.

3. At the border of the water courses in System II the section of flow reduces to zero. This particularity recurs in other problems of the same kind, and also in Chapter 6, where in several schemes the thickness of the fresh water layer reduces to zero near the coast, or near wells and galleries. If the system under consideration has no physical meaning, but is a mere term in the process of superposition, only the mathematical consequences need be examined; if it represents reality, the physical consequences must be studied as well.

– Mathematically speaking, if s is the coördinate perpendicular to the boundary, it follows from the law of linear resistance

$$q_s = -kD \frac{\partial \varphi}{\partial s}$$

that for $D \rightarrow 0$, $\frac{\partial \varphi}{\partial s} \rightarrow \infty$ at all border points where $q_s \neq 0$. Thus φ as a function of s shows a singularity at the boundary. But in any system, as in the present, where D is proportional to φ , ($D = c\varphi$), the same law may be written:

$$q_s = -kc\varphi \frac{\partial \varphi}{\partial s} = -\frac{kc}{2} \frac{\partial(\varphi^2)}{\partial s}$$

indicating that φ^2 as a function of s has no singularity at the boundary. It follows that there are no restrictions on superposition in terms of φ^2 at the boundary.

– Physically speaking, secondary phenomena will play a role. If q does not reduce to zero while the section reduces strongly, but not to zero, the velocities will be high, but not infinite. The law of linear resistance then may no longer be valid. The zone near the border should therefore be studied in detail from a physical viewpoint by methods that will not be described here (calculation, graphical methods, model study, observation in nature).

From such studies it may follow that

- The adapted scheme represents reality with sufficient precision for the use to be made of it. (The high velocities are local, and the precision of groundwater calculations is generally not high).
- A correction should be applied to the data as resulting from the scheme.
- The scheme should be abandoned.

In the following, where this particularity recurs, reference will be made to these remarks, while the analysis to be made will apply to the scheme in its simple form only.

3.3 PARALLEL FLOW

Figure 35. – As an example; the system of Section 2.2.2 (three canals) will be analysed here. The problem is the same as in the previous chapter, the only difference being that D is variable instead of constant. The model is defined by three parallel canals,

$\frac{l}{2}$ apart. The flow system is determined by

- potentials φ_1 and φ_2 in the outer canals.
- extraction q_0 per unit length from the middle canal
- uniform recharge n .

Following the same line of thought as in Sections 2.2.1 and 2.2.2., the formulas can be derived from the superposition of three systems. The formulas of the individual systems can be copied, after transformation, from those of the previous chapter. The bottom part of the figure shows the φ^2 lines of the different systems.

System I is defined by

- Potentials φ_1 and φ_2 in the outer canals.
- No extraction from the middle canal.
- No recharge.

For constant D the formulas were

$$\varphi - \varphi_1 = -\frac{x}{l}(\varphi_1 - \varphi_2)$$

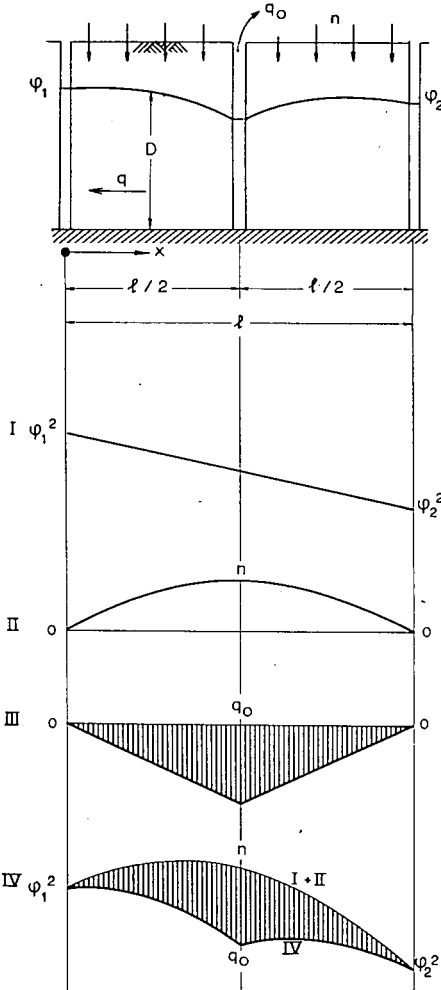

$$q = -kD \frac{\varphi_1 - \varphi_2}{l}$$

Replacing $D\varphi$ by $\varphi^2/2\gamma$:

$$\varphi^2 - \varphi_1^2 = -\frac{x}{l}(\varphi_1^2 - \varphi_2^2)$$

$$q = -k \frac{\varphi_1^2 - \varphi_2^2}{2l\gamma}$$

System II

- Zero potential in the outer canals.
- No extraction from the middle canal.
- Uniform recharge n .

For constant D the formulas were

$$\varphi = \frac{n}{2kD} x(l-x)$$

$$q = n \left(\frac{l}{2} - x \right)$$

After substitution

$$\varphi^2 = \frac{n\gamma}{k} x(l-x)$$

$$q = n \left(\frac{l}{2} - x \right)$$

System III

- Zero potential in the outer canals.
- Extraction q_0 per unit length from the middle canal.
- No recharge.

For constant D the formulas were (left-hand part of the aquifer)

$$\varphi = -\frac{q_0}{2kD} x$$

$$q = -q_0/2$$

After substitution

$$\varphi^2 = -\frac{q_0\gamma}{k}x$$

$$q = -q_0/2$$

Thus, by superposing the three systems,

$$\varphi^2 = \varphi_1^2 - \frac{x}{l}(\varphi_1^2 - \varphi_2^2) + \frac{\gamma n}{k}x(l-x) - \frac{q_0\gamma}{k}x$$

$$q = -\frac{k}{2l\gamma}(\varphi_1^2 - \varphi_2^2) + n\left(\frac{l}{2} - x\right) - \frac{q_0}{2}$$

In the φ^2 diagrams the ordinates of the shaded parts are equal. The figure demonstrates the remarks made about the characteristics of the function φ^2 near the boundaries. Although in Systems II and III $\partial\varphi/\partial x$ tends to infinity, this is not the case with $\partial(\varphi^2)/\partial x$: the φ^2 lines have no vertical tangents at the boundaries.

3.4. FLOW AROUND WELLS

The flow system around a single well sited in an infinite aquifer and pumped at a rate Q_0 is subject to the same restrictions as in the case of constant D . In the preceding chapter, Section 2.3.1, the formulas were

$$\varphi - \varphi_1 = \frac{Q_0}{2\pi k D} \ln \frac{r}{r_1}$$

$$q = Q_0/2\pi r$$

For variable D they become

$$\varphi^2 - \varphi_1^2 = -\frac{Q_0\gamma}{\pi k} \ln \frac{r}{r_1}$$

$$q = Q_0/2\pi r$$

For a finite value of φ in the well, the potential at infinite distance rises to infinite height; for a finite value at great distance, the potential in the well drops to infinite depth.

If the well is sited at a distance a from an infinitely long, straight canal with potential φ_c , the method of replacing the canal by an imaginary negative well can be used as in Section 2.4.3. The basic formulas can be copied, substituting $\varphi^2/2\gamma$ for φD . Thus, at a point S

$$\varphi^2 = \varphi_c^2 - \frac{Q_0 \gamma}{\pi k} \ln \frac{r_2}{r_1}$$

$$q = -\frac{aQ_0}{\pi r_1 r_2} e^{i(\theta_1 + \theta_2)} \text{ and } |q| = \frac{aQ_0}{\pi r_1 r_2}$$

where r_1 and r_2 are the distances from the point S to the real and the image well respectively. The potential in the well (radius r_0) is

$$\varphi_0^2 = \varphi_c^2 - \frac{Q_0 \gamma}{\pi k} \ln \frac{2a}{r_0}$$

The flow net formed by the streamlines and equipotential lines is identical to that of Chapter 2, provided the equipotential lines are drawn at equal increments of φ^2 and not of φ .

The problem of a well between two parallel canals, or between a canal and an impermeable boundary, will not be dealt with, since it is not essentially different from the corresponding problem in Chapter 2.

The problem of a well near a canal in uniform flow can also be copied from Chapter 2 (Section 2.4.4), when $D\varphi$ is replaced by $\varphi^2/2\gamma$. The transformation does not present any new element. The formulas will be given because they will be used in Chapter 6. The potential at an arbitrary point S at distances r_1 and r_2 from the real and the image wells respectively, is given by

$$\varphi^2 = \varphi_c^2 + \frac{2\gamma q_0}{k} x - \frac{\gamma Q_0}{\pi k} \ln \frac{r_2}{r_1}$$

or

$$\varphi^2 = \varphi_c^2 + \frac{n\gamma}{k} x - \frac{\gamma Q_0}{\pi k} \ln \frac{r_2}{r_1}$$

if the zone along the canal is considered as part of a broader aquifer, bounded on the other side, at distance l , by a second canal, as was assumed in Section 2.3.6. A model with a sloping aquifer may not be used, since the principle of superposition would not apply to it (D being no longer proportional to φ). The potential in the well (radius r_0) is given by

$$\varphi_0^2 = \varphi_c^2 + \frac{n\gamma}{k} a - \frac{\gamma Q_0}{\pi k} \ln \frac{2a}{r_0}$$

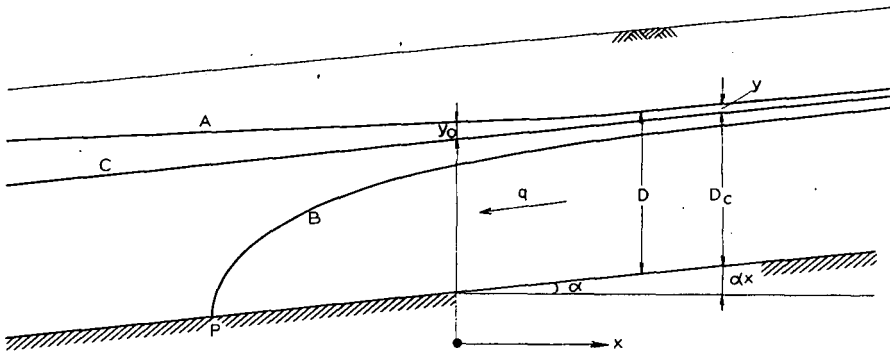

Fig. 36

The flow vector, finally, is defined as

$$q = -\frac{2a}{r_1 r_2} e^{i(\theta_1 + \theta_2)} - \frac{nl}{2}$$

as with constant D .

3.5 SLOPING BASE

For an aquifer with a gently sloping bottom, the principle of superposition is not valid. A complicated system cannot be considered as the sum of elementary systems; it must be calculated as a whole, which makes the integration more difficult.

Figure 36. – The simplest problem is that of a flow of constant intensity q_0 , directed along the lines of greatest slope. This problem has an infinity of solutions, defined commonly by

$$(1) \quad -\alpha x = (y - y_0) + D_c \ln(y/y_0)$$

where $D_c = q_0/k\alpha\gamma$, and y_0 is a parameter, corresponding to the value of y for $x = 0$. Three classes of solutions may be distinguished:

1. The value $y_0 = 0$ gives the solution of Chapter 2 with constant $D = D_c$. See line C in the figure.
2. Positive values of y_0 correspond to solutions of type A. The thickness of the aquifer increases in the direction of the flow, whilst the gradient decreases. At infinite distance to the left D becomes infinitely great and the gradient zero.
3. Negative values of y_0 correspond to solutions of type B. The thickness of the aquifer decreases in the direction of the flow, and the gradient increases. At P the thickness D becomes zero, and the gradient infinitely great.

Proof of formula (1).

$$(1) -\alpha x = y - y_0 + D_c \ln y/y_0$$

The basic formulas are

- The definition of the potential

$$(2) \varphi = \gamma(\alpha x + D_c + y)$$

- The law of linear resistance

$$(3) q = k(D_c + y) \frac{\partial \varphi}{\partial x}$$

- The law of continuity

$$(4) q = q_0$$

- The definition of D_c in the simplest system with $D = D_c = \text{constant}$

$$(5) q_0 = kD_c\alpha\gamma$$

Eliminating φ , q and q_0 from the four basic equations (2), (3), (4) and (5) results in

$$(6) (D_c + y) \frac{dy}{\partial x} + \alpha y = 0, \text{ or } \frac{dy}{dx} = -\alpha \frac{y}{D_c + y}$$

This differential equation relates y to x . Since it is of the first order, it needs one single condition for integration

$$\text{for } x = 0, \quad y = y_0$$

The proof that (1) is a solution of this differential equation (6) is given by differentiation; the proof that the condition satisfies (1) is given by substitution.

Analysis of the solution

1. From (2) and (6):

$$(7) \frac{dy}{dx} = \frac{\gamma\alpha D_c}{D_c + y}; \quad \frac{dh}{dx} = \frac{\alpha D_c}{D_c + y}$$

2. Since the argument of the logarithm in (1) must be positive, y is positive for positive values of y_0 and negative for negative values of y_0 . Thus the water table lies as a whole either above or below line C .

3. In both cases the water table approaches the line C on the extreme right, from (1): for $y \rightarrow 0$, $x \rightarrow +\infty$

from (7): for $y \rightarrow 0$, $\frac{dh}{dx} \rightarrow \alpha$

4. If y_0 is positive, y varies between 0 and ∞ . Zero value is approached at the extreme right ($x \rightarrow +\infty$). According to (6), dy/dx is always negative, which means that y increases steadily when x decreases (towards the left). According to (1),

$y \rightarrow \infty$ corresponds to $x \rightarrow -\infty$, while (7) indicates that for $y \rightarrow \infty$, $\frac{dh}{dx} \rightarrow 0$.
(horizontal water surface).

5. If y_0 is negative, y is negative, but for physical reasons y varies only between 0 and $-D_c$. As was shown, $y = 0$ corresponds to $x \rightarrow \infty$. According to (6), for y negative between zero and $-D_c$, dy/dx is positive: y decreases steadily with decreasing x , in other words $|y|$ increases steadily towards the left.

The value of x corresponding to $y = -D_c$ is determined by (1):

$$-ax = (-D_c - y_0) + D_c \ln \frac{-D_c}{y_0}$$

(point P in the figure). From the above it is clear that this value of x is negative. This can also be derived from the above expression when writing the logarithm as a series (not shown here).

According to (6), for $y = -D_c$, $\frac{dy}{dx} \rightarrow +\infty$, or, physically speaking, the water surface is vertical. Equation (7) indicates also that $\frac{dh}{dx} \rightarrow \infty$ at this point.

6. If $y_0 = 0$, equation (1) is satisfied by $y = 0$, but loses its structure. It is better to return to the basic equations (2), (3), (4) and (5).

As in the previous chapter, the question arises: Can steady flow exist around a well, extracting at a rate Q_0 from an infinite aquifer in which groundwater flows at a uniform rate q_0 , according to line C ? To answer this question no use can be made of the principle of superposition. The reply can, however, be given by comparison with the scheme of a sloping aquifer with constant D . When the losses of energy from infinity to the well are infinitely great for constant $D = D_c$, they will be greater still for variable $D < D_c$. Hence no steady flow exists.

4. STEADY FLOW, PARTLY CONFINED AQUIFER, GIVEN φ'

In the problems of this chapter not n , but φ' is given. Thus in

$$N = n = \frac{k'}{D'}(\varphi' - \varphi)$$

n and φ are the unknowns.

Physically, this condition may correspond to any of the following instances:

- In inundated fields the free water surface corresponds to a constant value of φ' .
- In areas with upward groundwater flow reaching the ground surface and resulting in surface run off towards ditches or low places in the field, φ' is defined by the ground level.
- In a drained region ditches or tiles narrowly spaced maintain the phreatic water table within certain limits. Neglecting the undulations between the drains, as well as the variations in time, an average, constant water table may be assumed.
- During a short period of nonsteady flow (e.g. a pumping test under certain conditions) a changing water table may be considered as steady. The same approximation is allowed for periodic fluctuations of φ' with small amplitude. (See Section 5.2.2., for instance, where the nonsteady flow is a succession of steady-state systems).
- In a scheme of superposition a constant φ' may be assumed for one of the elementary systems, when the other systems account for the variations.

4.1 SUPERPOSITION AND WATER RESOURCES

The principle of superposition may be applied when adding the following quantities: φ , q (either the vectors or the components), φ' and n .

The law of linear resistance

$$q_x = -kD \frac{\partial \varphi}{\partial x}; \quad q_y = -kD \frac{\partial \varphi}{\partial y}$$

is linear in q_x , q_y and φ , since kD is constant. The law of continuity

$$\frac{\partial q_x}{\partial x} + \frac{\partial q_y}{\partial y} = \frac{k'}{D'} (\varphi' - \varphi) = n = N$$

is linear in q_x , q_y , φ' , φ and n .

The question of the water resources, applied to the conditions of this chapter, would be the question of the origin of the water extracted from an aquifer where φ' is maintained at given values, notwithstanding the extraction. It is clear that this water is provided partly by lateral flow into the aquifer – as it was in the preceding section – and partly by increase of the recharge n . The analysis of the latter point will not be developed here, since maintaining the water level by changing the recharge is a practical rather than a theoretical problem.

4.2 PARALLEL FLOW

In this section a series of flow systems will be examined, derived from one another by means of the principle of superposition. In all schemes parallel flow in a partly confined aquifer is assumed.

4.2.1 One canal

Figure 37. – The first scheme is defined by an aquifer with constant $\varphi' = \varphi_0'$, bounded on the left by a canal, where $\varphi = \varphi_0$, and extending infinitely to the right. The formulas are:

$$\varphi_0' - \varphi = (\varphi_0' - \varphi_0) e^{-ax}$$

$$q = q_0 e^{-ax}$$

where $a = \sqrt{\frac{k'/D'}{kD}}$ and $q_0 = \sqrt{kD k'/D'} (\varphi_0' - \varphi_0)$

The law of linear resistance reads

$$q = kD d\varphi/dx$$

The law of continuity

$$\frac{dq}{dx} = -\frac{k'}{D'} (\varphi'_0 - \varphi)$$

Eliminating q yields

$$\frac{d^2(\varphi'_0 - \varphi)}{dx^2} - a^2 (\varphi'_0 - \varphi) = 0$$

The general solution of this linear differential equation with constant coefficients is

$$\varphi'_0 - \varphi = c_1 e^{ax} + c_2 e^{-ax}$$

where c_1 and c_2 are integration constants, to be determined from the following conditions:

$$\text{for } x \rightarrow \infty, \quad \varphi \rightarrow \varphi'_0$$

which implies $c_1 = 0$

$$\text{for } x = 0, \quad \varphi = \varphi_0$$

which gives $c_2 = \varphi'_0 - \varphi_0$.

The formula for q is found by differentiating the expression for φ .

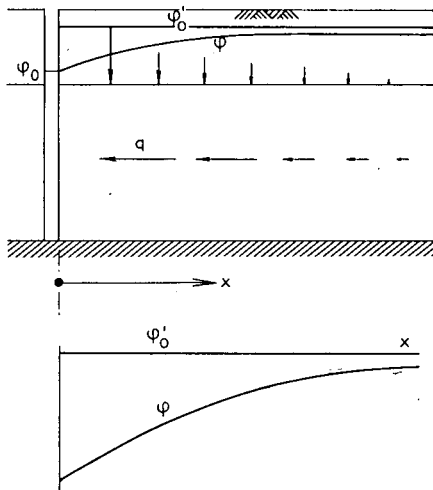

Fig. 37

Both $\varphi'_0 - \varphi$ and q are maximum at the canal border. With increasing x , they both decrease proportionally to e^{-ax} ; thus their ratio is the same in each section.

$$\frac{q}{\varphi'_0 - \varphi} = \frac{q_0}{\varphi'_0 - \varphi_0} = \sqrt{kD \cdot k'/D'}$$

Both vanish at infinite distance from the canal. (A series of values of e^{-ax} can readily be calculated, using the property that the function is multiplied by the same factor $e^{-a\Delta x}$ each time the argument increases with the same term Δx).

4.2.2 Two different phreatic levels

Figure 38. – Whereas in the previous section the scheme was determined by a value of φ' , (φ'_0), and a value of φ , (φ_0), in the next example it will be defined by two values of φ' , (φ'_1 and φ'_2). The value of φ'_1 is characteristic of the left-hand part of the model to infinity; the value of φ'_2 applies to the right-hand part. The transition in the middle section is abrupt.

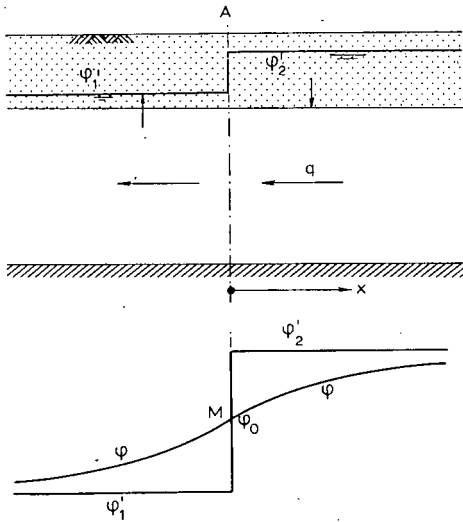

Fig. 38

The φ diagram is symmetrical about the point M , where

$$\varphi = \varphi_0 = \frac{1}{2}(\varphi'_1 + \varphi'_2)$$

This consideration reduces the problem to the previous one with, for the right hand half of the aquifer

$$\varphi'_2 - \varphi = \frac{\varphi'_2 - \varphi'_1}{2} e^{-ax}$$

$$q = q_0 e^{-ax}$$

$$\text{where } a = \sqrt{\frac{k'D'}{kD}} \text{ and } q_0 = \sqrt{kD k'D'} \frac{\varphi'_2 - \varphi'_1}{2}$$

4.2.3 ϕ' constant between two canals

Figure 39. – The aquifer is bounded by two parallel canals A and B, in which the water levels correspond to the potentials ϕ_1 and ϕ_2 respectively. Between A and B, $\phi' = \phi'_0$.

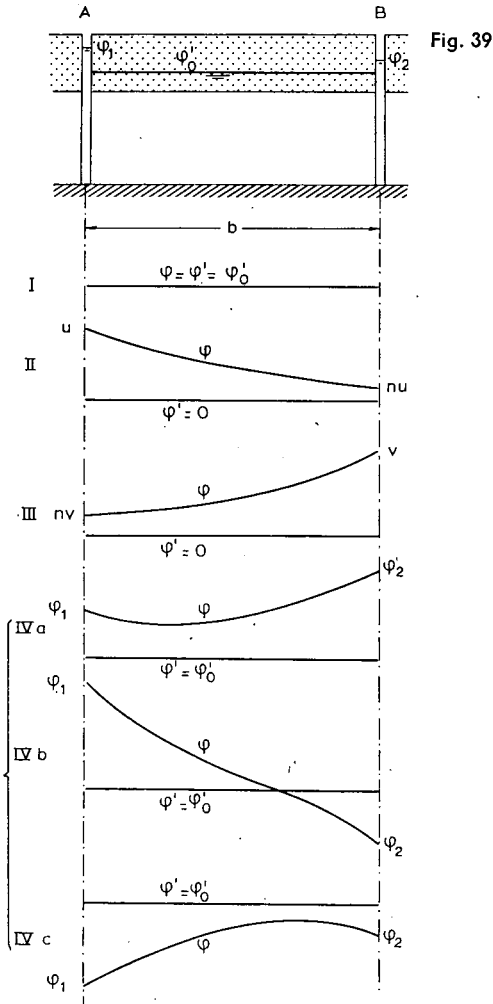

The solution reduces to that of Section 4.2.1 by the superposition of three systems, I, II and III, whose sum is System IV.

System I:

- $\varphi' = \varphi'_0$ in the top layer.
- $\varphi = \varphi'_0$ in both canals.

It is clear that no flow occurs ($q = 0$), while $\varphi = \varphi'_0$ in all points of the aquifer.

System II:

- $\varphi' = 0$ in the top layer.
- $\varphi = u$ (unknown value) in canal A.
- In canal B, $\varphi = ue^{-at} = nu$, which is the value φ would have according to the formula of Section 4.2.1, if no water were extracted from canal B, and the aquifer extended to infinity to the right.

The values of φ and q in the aquifer as functions of x are determined by the formulas of Section 4.2.1.

System III is the reverse of System II;

- $\varphi' = 0$ in the top layer
- $\varphi = v$ (unknown) in canal B
- In canal A, $\varphi = ve^{-at} = nv$.

Summing the three systems and writing φ_1 and φ_2 for φ in the canals A and B respectively.

$$\varphi'_0 + u + nv = \varphi_1$$

$$\varphi'_0 + nu + v = \varphi_2$$

which conditions determine u and v .

Since φ_1 and φ_2 may be positive as well as negative, the φ line of System IV may assume different forms, some of which are indicated as examples in the figure (IVa, IVb, IVc). It can readily be shown that the inflection point corresponds to the section where $\varphi = \varphi'_0$.

For $\varphi = \varphi'_0$, $dq/dx = 0$, and therefore $d^2\varphi/dx^2 = 0$.

4.2.4 Arbitrary φ' values

Between the sections A and B, φ' varies smoothly as an arbitrary, in principle non-analytic function of x . To the left of A and to the right of B, to infinity, φ' is constant, equal to φ'_0 .

The first step in solving the problem is to replace the smooth φ' curve of Fig. 40b by the step curve of Fig. 40c. Calculation is then possible by multiple superposition, according to Fig. 40d, using the formulas of Section 4.2.2.

Another way of superposition is indicated in Fig. 40e. The elementary system, recurring in this figure, can be calculated according to Fig. 40f, where, as an example,

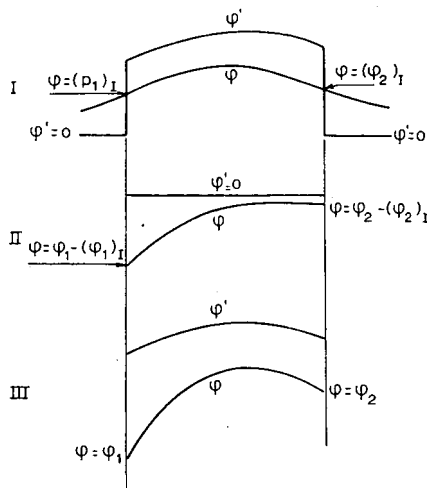
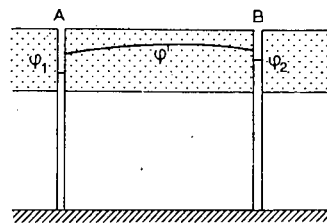
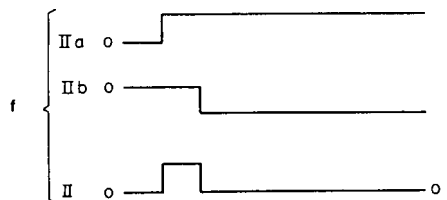
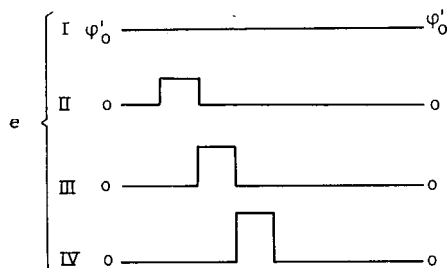
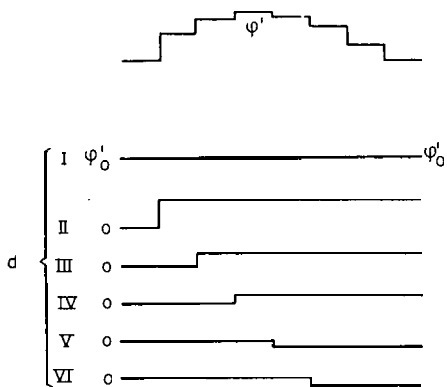
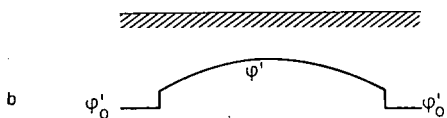

Fig. 41

Fig. 40

System II is found as the sum of Systems IIa and IIb, again of the type described in Section 4.2.2.

4.2.5 Arbitrary φ' values between two canals

Figure 41. – The aquifer is bounded by two parallel canals whose water levels correspond to the potentials φ_1 and φ_2 . Between the canals, φ_1 is given as an arbitrary, generally non-analytic, function of x . The system is the sum of two elementary Systems I and II:

System I corresponds to that of the previous section defined by

- Absence of canals
- φ' equal to zero outside the axes A and B to infinity.
- Values of φ' inside the canal axes equal to those of the present scheme.

The flow system can be calculated following the methods indicated in the previous section. In particular the values of φ in A and B can be found: $(\varphi_1)_I$ and $(\varphi_2)_I$.

System II corresponds to that described in Section 4.2.3:

- In the axes A and B , the potentials are $\varphi_1 - (\varphi_1)_I$ and $\varphi_2 - (\varphi_2)_I$ respectively.
- Between the canals $\varphi' = 0$.

4.3 RADIAL FLOW

4.3.1 Bessel functions

Figure 42. – In the following sections solutions will be given in the form of Bessel functions. Since the theory of these functions is not generally known, its relevant parts will first be summarized.

The differential equation

$$(1) \quad \frac{d^2y}{dx^2} + \frac{1}{x} \frac{dy}{dx} - y = 0$$

is a linear equation of the second order with second member = 0. If $y = \phi_1(x)$ and $y = \phi_2(x)$ are two particular solutions, the general solution can be written as

$$y = c_1 \phi_1(x) + c_2 \phi_2(x)$$

where c_1 and c_2 are integration constants. Traditionally the general solution is written as

$$(2) \quad y = c_1 K_0(x) + c_2 I_0(x).$$

The function $I_0(x)$ is a particular solution of (1), defined by the following conditions:

$$\begin{aligned} \text{for } x = 0, \quad I_0(x) &= 1 \\ \text{for } x = 0, \quad I_0'(x) &= 0 \quad (I_0' = dI_0/dx) \end{aligned}$$

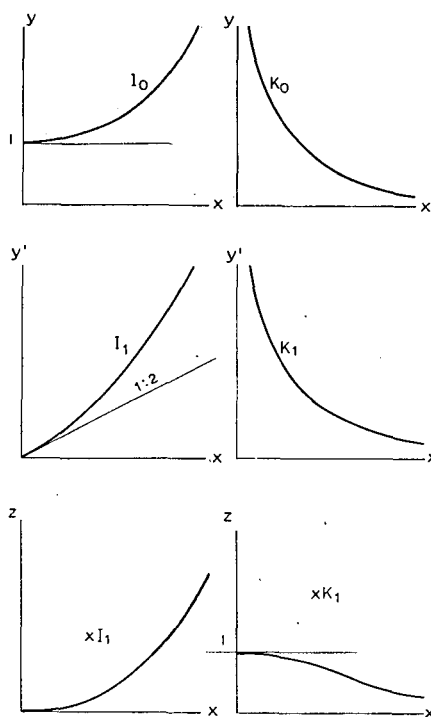

Fig. 42

This function can be written as a series:

$$I_0(x) = 1 + \frac{x^2}{2^2} + \frac{x^4}{4^2 2^2} + \frac{x^6}{6^2 4^2 2^2} \dots$$

For small values of x , $I_0(x) = 1$, as can be seen from the series.

The function $K_0(x)$ is also a particular solution of (1), for the conditions

$$\text{for } x = 0 \quad K_0 = \infty$$

$$\text{for } x = \infty \quad K_0 = 0$$

These conditions do not define the function fully, since any multiple of K_0 would satisfy them as well. The complete definition of the function, however, is generally given in an indirect way, and will not be formulated here, nor will the development in a series. For small values of x ,

$$K_0(x) = \ln(1,123/x)$$

As can be seen from these definitions, for arbitrary values of c_1 and c_2 , (2) gives

infinite values of y , either positive or negative, for both $x = 0$ and $x = \infty$.

The derivatives of the functions I_0 and K_0 are traditionally indicated

$$\frac{d}{dx} I_0(x) = I_1(x) \quad \frac{d}{dx} K_0(x) = -K_1(x)$$

The function $I_1(x)$ can be written as a series

$$I_1(x) = \frac{x}{2} + \frac{x^3}{4 \cdot 2^2} + \frac{x^5}{6 \cdot 4^2 \cdot 2^2} \dots$$

For small values of x , $I_1(x) = 1/2x$. The series for $K_1(x)$ will not be given. For small values of x ,

$$K_1(x) = 1/x$$

In the problems of the following sections the quantity

$$z = x \, dy/dx$$

plays a role. It is a solution of the differential equation

$$\frac{d^2 z}{dx^2} - \frac{1}{x} \frac{dz}{dx} - z = 0$$

which differs from the previous differential equation only in the sign of the second term. The general solution can be written as

$$z = c_1 x K_1(x) + c_2 x I_1(x)$$

where c_1 and c_2 are integration constants.

For the values of K_0 , I_0 , K_1 and I_1 reference is made to mathematical tables, as listed at the end of the publication. Sometimes the functions are indicated differently, according to the following correlation:

$$\frac{\pi}{2} i H_0^{(1)}(ix) = K_0(x)$$

$$-\frac{\pi}{2} H_1^{(1)}(ix) = K_1(x)$$

$$J_0(ix) = I_0(x)$$

$$-i J_1(ix) = I_1(x)$$

4.3.2 Flow in and around a circular area

Figure 43 represents a cross-section of a circular area with radius R , inside of which

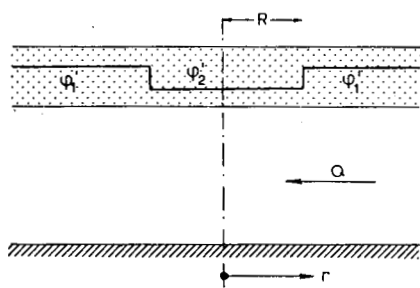

Fig. 43

$\varphi' = \varphi'_2$, and outside of which $\varphi' = \varphi'_1$, to infinity. Physically the scheme may represent a circular, drained area, surrounded by marshes or by an area drained at a higher level.

The solution can be written in Bessel functions:

For the outside part:

$$\varphi - \varphi'_1 = m_1 K_0(ar)$$

$$\frac{Q}{2\pi kD} = -m_1 ar K_1(ar)$$

For the inside part:

$$\varphi - \varphi'_2 = n_2 I_0(ar)$$

$$\frac{Q}{2\pi kD} = n_2 ar I_1(ar)$$

where

$$a = \sqrt{\frac{k'D'}{kD}}$$

$$m_1 = -\frac{I_1(aR)}{K_0(aR)I_1(aR) + I_0(aR)K_1(aR)} (\varphi'_1 - \varphi'_2)$$

$$n_2 = \frac{K_1(aR)}{K_0(aR)I_1(aR) + I_0(aR)K_1(aR)} (\varphi'_1 - \varphi'_2)$$

The law of linear resistance reads:

$$Q = kD2\pi r \frac{d\varphi}{dr}$$

the law of continuity:

$$\frac{dQ}{dr} = \frac{k'}{D'} 2\pi r(\varphi - \varphi')$$

where φ' equals φ'_1 and φ'_2 in the outer and inner part respectively.

Elimination of Q gives

$$\frac{d^2(\varphi - \varphi')}{d(ar)^2} + \frac{1}{ar} \frac{d(\varphi - \varphi')}{d(ar)} - (\varphi - \varphi') = 0$$

where

$$a = \sqrt{\frac{k'D'}{kD}}$$

The general solution of this differential equation reads:

$$\varphi - \varphi' = mK_0(ar) + nI_0(ar).$$

Substituting this value of φ in the law of linear resistance yields,

$$\frac{Q}{2\pi kD} = -mar K_1(ar) + nar I_1(ar).$$

For the outer part

$$\varphi' = \varphi'_1, \quad m = m_1, \quad \text{and} \quad n = n_1$$

For the inner part

$$\varphi' = \varphi'_2, \quad m = m_2, \quad \text{and} \quad n = n_2$$

Thus the solution depends on the values of four constants m_1, n_1, m_2 and n_2 . These values are determined by the following four conditions:

1. In the outer part

$$\text{for } r = \infty, \quad \varphi - \varphi'_1 = 0 \quad (\text{or } Q = 0)$$

This condition gives in either way of formulation $n_1 = 0$, otherwise both $\varphi - \varphi'_1$ and Q would be infinite. Thus in the outer part

$$\varphi - \varphi'_1 = m_1 K_0(ar)$$

$$\frac{Q}{2\pi kD} = -m_1 ar K_1(ar)$$

2. In the inner part the symmetry condition

$$\text{for } r = 0, \quad Q = 0$$

gives $m_2 = 0$, otherwise Q would be infinite for $r = 0$. Thus in the inner part

$$\varphi - \varphi'_2 = n_2 I_0(ar)$$

$$\frac{Q}{2\pi kD} = n_2 ar I_1(ar)$$

3. and 4. For $r = R$ the values of φ and Q of the inner and outer part reach the same value. Thus

$$\begin{aligned} n_2 I_0(aR) - m_1 K_0(aR) &= \varphi'_1 - \varphi'_2 \\ -m_1 K_1(aR) &= n_2 I_1(aR) \end{aligned}$$

From these two equations m_1 and n_2 can be calculated.

4.3.3 Flow around a well

Figure 44. – From a well in an infinite aquifer ($\varphi = \varphi'$) water is extracted at a constant rate Q_0 . The problem is essentially the same as that for the outer part in the previous section, when R reduces to the radius r_0 of the well. Unlike a well in a phreatic or a fully confined aquifer, the present scheme corresponds to a steady flow system. The formulas are:

$$(1) \quad \varphi - \varphi' = -\frac{Q_0}{2\pi kD} K_0(ar)$$

$$(2) \quad Q = Q_0 ar K_1(ar)$$

where

$$a = \sqrt{\frac{k'D'}{kD}}$$

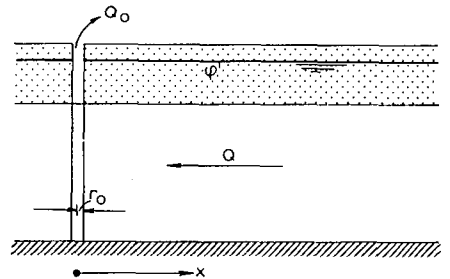

Fig. 44

In the previous section the formulas for the outer part were (writing φ' instead of φ'_1 , and r_0 instead of R):

$$(3) \quad \varphi - \varphi' = m_1 K_0(ar)$$

$$(4) \quad Q/2\pi kD = -m_1 ar K_1(ar)$$

When substituting in (4) the condition

$$\text{for } r = r_0, \quad Q = Q_0,$$

m_1 can be found:

$$m_1 = -Q_0/2\pi kD ar_0 K_1(ar_0)$$

and since for small values of ar , $K_1(ar) \rightarrow 1/ar$,

$$m_1 = -Q_0/2\pi kD$$

which, substituted in (3) and (4), gives (1) and (2)

For small values of ar ,

$$K_0(ar) \rightarrow \ln \frac{1,123}{ar}$$

and

$$K_1(ar) \rightarrow 1/ar$$

Thus, at short distance from the well

$$\varphi - \varphi' = - \frac{Q_0}{2\pi kD} \ln \frac{1,123}{ar}$$

$$Q = Q_0$$

The constant value of Q indicates that the recharge in a small circular area around the well may be neglected because of the small surface area, notwithstanding the great values of $\varphi' - \varphi$. Thus the logarithmic function known from confined aquifers reappears. Whereas in the case of a confined aquifer the drawdown was infinitely great, it is now limited to a finite value. The explanation is that in a confined aquifer the full rate Q_0 is transported through the aquifer from infinite distance to the well, whereas in a partly confined aquifer, due to the recharge, this quantity increases from zero to the extraction rate of the well.

As in problems with $n = 0$, there is no radius of influence. For practical purposes, however, a limit can be defined conventionally, e.g. as the distance from the well where Q reduces to 5% or 10% of the rate of extraction from the well.

4.3.4 Several wells

Figure 45. - If several wells A, B, C, D, E etc. are sited in an aquifer with constant φ' , extending to infinity, the question may arise: what is the influence of all wells together on the potential φ at a point P ? It can be found from superposition of the following systems.

- System I without wells, where φ' has the real value. Since in this system the aquifer is at rest, $\varphi = \varphi'$ at all points, e.g. at P .
- System II, characterized by $\varphi' = 0$ and extraction from well A only.
- System III, characterized by $\varphi' = 0$ and extraction from well B only.
- Similarly for the other wells.

The calculation does not present any special difficulty, but if it has to be made for a great number of points P , it can be speeded up by the following method. To explain the principle, it will first be assumed that the extraction rate from all wells is equal to unity.

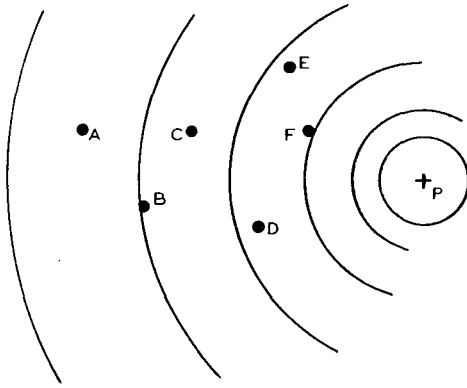

Fig. 45

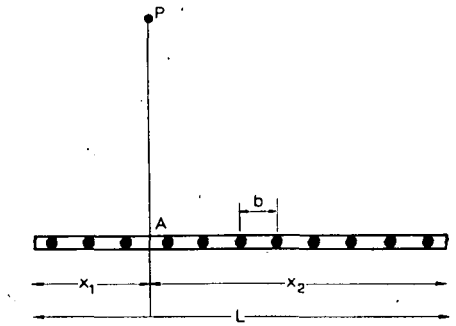

Fig. 46

The plan of the wells is drawn to a certain scale on white paper. To the same scale, but on transparent paper, concentric circles are drawn around a well with unit discharge, at such distances that the drawdown on each circle corresponds to a round figure: 1 m, 0,90 m, 0,80 m, 0,70 m etc. If the centre of the circles is laid successively on each well, the drawdown at point P can be read each time, and the results can be summed. But since the influence at P of a well at A is the same as the influence at A of a well with the same capacity at P , the centre of the circles can more conveniently be laid on the point P , and the values at A, B, C, D etc. read and summed, which gives the same result.

If the discharges are different, the same method can be used, if before summation each reading is multiplied by the extraction rate from the corresponding well.

4.3.5 Canal of limited length

Figure 46. – From a canal with limited length L , in an infinite aquifer with $\varphi' = 0$, water is extracted at a rate qL . For an approximate calculation the canal can be replaced by a series of wells at equal distances b , each extracting a quantity of flow qb . This arrangement differs in two points from the reality: firstly in that the drawdown in the canal is smaller than that in the wells and greater than that midway between two wells; secondly in that the drawdown in the wells near the extremities of the canal is smaller than that in the wells near the centre, whereas the water table in the canal is level. Although the problem can be solved for wells with equal drawdown and different extraction rates, this solution, requiring iteration methods, will not be examined here. Equal extracting rates from the wells will be assumed, which leads to the following results:

1. At a point P , some distance from the canal, the drawdown can be calculated by

summation of the influences of the wells, applying the method developed in the previous section. If the number of wells is not too small, and the distance from the canal sufficiently great compared with the distance between the wells in the series, the approximation may suffice for an orientating calculation.

2. At any point of the canal at distances x_1 and x_2 from the extremities, the drawdown can be found at its exact value by increasing the number of wells infinitely, the extraction rate of each well becoming qdx . Under these conditions a varying drawdown in the axis is found, smallest near the ends, greatest in the middle section. At any point at distances x_1 and x_2 from the ends of the canal, ($x_1 + x_2 = L$), the drawdown is

$$\varphi = -\frac{q}{a2\pi kD} \left[\int_0^{x_1} K_0(ax)d(ax) + \int_0^{x_2} K_0(ax)d(ax) \right].$$

3. If the length of the canal is extended infinitely, the drawdown at all points of the canal becomes the same. Its value is without approximation

$$\varphi = -\frac{q}{a2\pi kD} 2 \int_0^{\infty} K_0(ax)d(ax)$$

and since

$$\int_0^{\infty} K_0(s)ds = \frac{\pi}{2},$$

$$\varphi = -q/2akD$$

which was the result obtained in Section 4.2.1.

5. NONSTEADY FLOW (CONSTANT D)

5.1 FUNDAMENTALS

5.1.1 *Elasticity*

Throughout this chapter inelastic water and soil will be assumed. In reality three factors play a role:

(1) the elasticity of the water, (2) the elasticity of the grain material and (3) the changes in pore space due to slight displacements of the grains (compaction). Generally (2) can be neglected in comparison with (1). Only the elasticity of the water and the displacements of the grains need be considered. Thus the term elasticity may be applied to the sum of these two influences.

In the case of a confined aquifer the propagation of pressure waves is instantaneous when elasticity and inertia are neglected; when these factors are taken into account, a rapid, but not instantaneous, propagation is found.

In the case of a phreatic aquifer water may be released in two ways: (1) lowering of the water table and (2) elasticity due to lowering of the pressure. If the losses of energy in a vertical direction are neglected, both are proportional to the fall of the water table. They may be added, but then (2) is negligible compared with (1).

In the case of a partly confined aquifer the elasticity of a clayey or silty top layer may be higher, and of another order of magnitude than that of the aquifer. It should therefore be studied if this elasticity plays a role, and under which circumstances.

Up to now fragmentary studies have been made on the influence of elasticity on nonsteady flow problems. They should be completed, and the order of magnitude of the quantities involved examined, so as to define the conditions in which the effect of

elasticity is to be neglected or taken into account. Since the results of such a study are not yet completely available, the effect of elasticity will be ignored in the following chapters.

5.1.2. Differential equations and superposition

The differential equations read:

- law of linear resistance

$$q_x = -kD \frac{\partial \varphi}{\partial x} \quad q_y = -kD \frac{\partial \varphi}{\partial y}$$

- law of continuity

$$\frac{\partial q_x}{\partial x} + \frac{\partial q_y}{\partial y} = N$$

where

a. In a confined aquifer

$$N = 0$$

while D is constant. The formulas define φ and q (q_x and q_y) as functions of x , y and t .

b. In a partly confined aquifer

$$N = \frac{k'}{D'} (\varphi' - \varphi) = n - \mu' \frac{\partial \varphi'}{\partial t}$$

while D is constant. If φ' is given as a function of x , y and t , the formulas define φ , q and n as functions of the same variables. If n is given they define φ' instead of n .

c. In a phreatic aquifer

$$N = n - \mu \frac{\partial \varphi}{\partial t}$$

while D is either approximately a constant (independent of x , y and t) or a variable, related to φ by

$$D = \frac{\varphi}{\gamma} + c$$

where c depends on the choice of the reference level. In either case the equations define φ and q as functions of x , y and t , if n is given as a function of the same variables.

Normally the formulas of a scheme should be deduced from the above equations, combined with conditions (initial condition and boundary conditions). But in the

examples of the following sections they have been found in an indirect way, and the conditions have been established, if at all, after the mathematical solution had been found. Moreover, in the case of sinusoidal waves, the initial condition is replaced by the condition of perpetual repetition. Thus, no example of a systematic solution has been given.

The possibility of superposition depends on the same equations. If D is a constant, either exactly or approximately, summation is possible for the values of ϕ , q , N and n (and ϕ' in the case of a partly confined aquifer). The derivatives of ϕ , ϕ' and q with respect to x , y and t are summed as well as the quantities themselves. The proof follows directly from the fact that the equations are linear in these quantities.

5.1.3 Water resources

With respect to the water resources of an aquifer, nonsteady flow may be considered from two points of view:

1. From the moment extraction from a phreatic aquifer begins, the water table falls until steady flow is reached. The quantity of water released constitutes a yield of the aquifer, but its calculation follows from comparison between the initial and final steady state, and therefore does not involve the theory of nonsteady flow. This aspect of the problem will not be discussed in this chapter.
2. The theory of nonsteady flow applies when the extraction during the seasons does not correspond to the quantities which the aquifer receives from recharge and lateral inflow. Dry seasons and periods of shortage or lack of water in the rivers play a role, especially when they coincide with periods of high water demands, e.g. for irrigation. A phreatic aquifer may then serve as a storage basin. A partly confined aquifer with varying water table acts in the same way, but its capacity is less, since the effective pore space of the top layer is generally low. Engineering problems in this category are generally complicated. Only elementary problems will be dealt with, to be used as a basis for the solution of practical problems.

5.2 ELEMENTARY SINUSOIDAL WAVES (PARALLEL FLOW)

Figure 47. – In this section four schemes A , B , C and D will be examined. System D , shown in the figure, is the most general. For certain particular values of the constants involved it can be reduced to any of the schemes A , B or C . The systems will first be examined separately (Sections 5.2.1 – 5.2.4). Then the reduction of the formulas of D to those of A , B and C will be shown (Sections 5.2.5 – 5.2.7).

The schemes are commonly characterized by nonsteady, parallel flow in an aquifer with constant D , without recharge, traversed by a long straight canal; the aquifer extends at either side to infinity where $\phi = 0$. In the canal the water level fluctuates around zero level as a sine function of time, according to

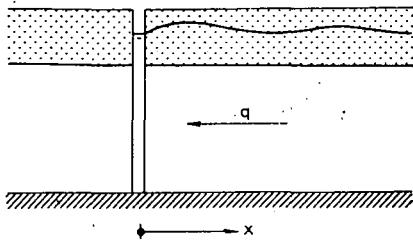

Fig. 47

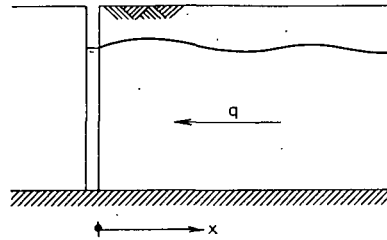

Fig. 48

$$\varphi = \varphi_0 \sin \omega t$$

where $\omega = 2\pi/T$ ($T = \text{period}$).

The four schemes are different as to the nature of the aquifer:

A: Phreatic aquifer.

B: Partly confined aquifer ($\varphi' = 0$).

C: Confined aquifer.

D: Partly confined aquifer with variable φ' .

The formulas for both sides of the canal will be given, but for the analysis, only the right-hand side will be considered. The formulas of both sides will be used in the next section (5.3).

5.2.1 Scheme A (phreatic aquifer)

Figure 48. - The formulas are:

$$\varphi = \varphi_0 e^{ax} \sin(\omega t + ax)$$

$$q = q_0 e^{ax} \sin(\omega t + \beta + ax)$$

$$q_0 = \varphi_0 \sqrt{\mu\omega kD}$$

where φ_0 and q_0 are positive numbers: the sign of φ or q varies with the sign of the sine function.

The values of β and a are different at either side of the canal

- At the right-hand side

$$\beta = \frac{5}{8} 2\pi \quad a = -\sqrt{\frac{\mu\omega}{2kD}}$$

Since a is negative, e^{ax} decreases with increasing x , which means that the amplitudes of φ and q decrease to the right.

- At the left-hand side

$$\beta = \frac{2\pi}{8} \quad a = + \sqrt{\frac{\mu\omega}{2kD}}$$

Since a is positive, e^{ax} decreases with decreasing x ; thus the amplitudes of φ and q decrease to the left.

The differential equations are:

- The law of linear resistance:

$$(1) \quad q = kD \frac{\partial \varphi}{\partial x}$$

- The law of continuity:

$$(2) \quad \frac{\partial q}{\partial x} = \mu \frac{\partial \varphi}{\partial t}$$

At the outset it is supposed that the solution has the following form:

$$(3) \quad \varphi = \varphi_0 e^{ax} \sin(\omega t + ax)$$

$$q = q_0 e^{ax} \sin(\omega t + \beta + ax)$$

to be written as:

$$(4) \quad q = q_0 e^{ax} [\sin(\omega t + ax) \cos \beta + \cos(\omega t + ax) \sin \beta]$$

where a and β are still unknown.

From (3) and (4) the values of $\frac{\partial \varphi}{\partial x}$, $\frac{\partial \varphi}{\partial t}$ and $\frac{\partial q}{\partial x}$ can be found by differentiation.

Upon substitution in (1) and (2) two equations are found containing terms with $\sin(\omega t + ax)$ and $\cos(\omega t + ax)$. The solution should be valid for all values of x and t , which implies that the terms with $\sin(\omega t + ax)$ and with $\cos(\omega t + ax)$ satisfy individually. Thus each equation separates into two conditions, which gives a total of four equations.

$$(5) \quad \text{Sine terms of (1): } q_0 \cos \beta = kD \varphi_0 a$$

$$(6) \quad \text{Cosine terms of (1): } q_0 \sin \beta = kD \varphi_0 a$$

$$(7) \quad \text{Sine terms of (2): } \cos \beta - \sin \beta = 0$$

$$(8) \quad \text{Cosine terms of (2): } q_0 a (\sin \beta + \cos \beta) = \mu \varphi_0 \omega$$

From (5) and (6), or from (7), it follows that $\cos \beta = \sin \beta$, which corresponds to

$$\beta = \frac{5}{8} 2\pi \quad \text{or} \quad \beta = \frac{1}{8} 2\pi.$$

- The value $\beta = \frac{5}{8} 2\pi$ applies to the right-hand side of the aquifer. It corresponds

$$\text{to } \cos \beta = \sin \beta = -\frac{1}{2} \sqrt{2}$$

From (5): $q_0/a = -\varphi_0 k D \sqrt{2}$

From (8): $q_0 a = -\frac{1}{2} \sqrt{2} \varphi_0 \mu \omega$

Thus q_0 and a can be calculated from their ratio and their product.

- The value of $\beta = \frac{1}{8} 2\pi$ applies to the left-hand side of the aquifer. It results in

$$\cos \beta = \sin \beta = \frac{1}{2} \sqrt{2}$$

$$q_0/a = \varphi_0 k D \sqrt{2}$$

$$q_0 a = \frac{1}{2} \sqrt{2} \varphi_0 \mu \omega.$$

From the given formulas the following properties of the flow system can be derived (valid for the right-hand side of the aquifer):

- φ and q are sine functions of the time with the same period $T = 2\pi/\omega$. Both vary around the zero value. As to φ , this means that the water level in the canal as well as in any point of the aquifer varies around an average elevation equal to zero. As to q , it means that in any section the water movement is alternatively towards the left and towards the right, without resulting flow.

- In the canal the amplitudes of φ and q are φ_0 and q_0 . Both are damped with increasing x , vanishing at great distance from the canal. The law of damping for φ and q is characterized by a common factor e^{ax} . Thus in any section the ratio of the amplitudes of φ and q is the same, and equal to that in the canal

$$\frac{q_0}{\varphi_0} = \sqrt{\mu \omega k D}$$

- At the canal border the phase of q leads that of φ by $\frac{5}{8} 2\pi$. At distance x this difference is maintained, but both phases are commonly delayed by $|ax|$ with respect to the canal.

- The time lag $|ax|$, proportional to x , has as an effect that the phase of φ or q does not change for an observer moving away from the canal at a constant velocity ω/a , while the amplitudes, although decreasing, conserve their ratio. This particularity has given rise to the notion of (damped) waves, propagating with a constant velocity $c = \omega/a$. Two remarks should be made concerning this point: firstly the speed of the waves has nothing to do with the velocity of the water. The first is constant to the right; the second varying in direction. Their order of magnitude may also be very

different. Secondly, the notion of a constant speed of propagation is reduced to this problem. In other similar problems (e.g. Section 5.4.1) no hydraulic characteristic can be found which remains unchanged for an observer moving away from the canal at constant velocity.

– Since the phase lag with respect to the canal is proportional to x , it can theoretically amount to any value: π , 2π , etc. For a difference π the movement would be opposite to that of the canal; for 2π it would be in phase again. Yet these greater differences are not relevant because the waves are damped too much. For a lag of π the amplitudes of φ and q are already reduced to 4% of their values in the canal.

– It is a basic assumption of the present studies that the losses of energy in a vertical direction are negligible. If the formulas are applied to homogeneous soil, this means that the vertical velocity components are small compared with the horizontal components. The formulas given define for a section at distance x from the canal, φ and q as functions of time, and therefore the vertical velocity component at the water surface, related to φ , and the horizontal component in the whole section, related to q . Both are sine functions of time. When comparing their amplitudes the condition is that

$$\sqrt{\frac{k}{\mu\omega D}} \gg 1$$

Rapid variations, as caused by tidal movement for instance, do not always satisfy this condition.

At distance x from the canal, the vertical velocity component at the surface is

$$u = \mu \frac{\partial \varphi}{\partial t} = \mu \omega \varphi_0 e^{ax} \cos(\omega t + ax)$$

with a half amplitude of $\mu \omega \varphi_0 e^{ax}$ (the word velocity taken in the sense of the volume of water displaced per unit time through a unit area including the section over the grains). At that distance from the canal the horizontal component of the velocity is equal to

$$v = \frac{q}{D} = \frac{q_0}{D} e^{ax} \sin(\omega t + \beta + ax)$$

with a half-amplitude of $\frac{q_0}{D} e^{ax}$. Comparison of the amplitudes gives the result stated.

5.2.2. Scheme B (partly confined aquifer, $\varphi' = 0$)

Figure 49. – The formulas are

$$\varphi = \varphi_0 e^{ax} \sin \omega t$$

$$q = q_0 e^{ax} \sin (\omega t + \beta)$$

$$q_0 = \varphi_0 \sqrt{kD k'/D'}$$

where φ_0 and q_0 are positive.

– For the right-hand part of the aquifer

$$\beta = \pi \quad a = - \sqrt{\frac{k'D'}{kD}}$$

– For the left-hand part

$$\beta = 0 \quad a = + \sqrt{\frac{k'D'}{kD}}$$

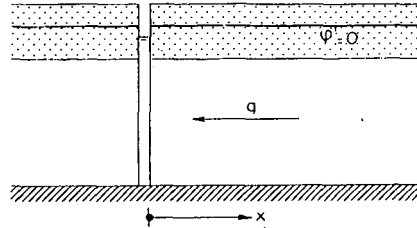

Fig. 49

The differential equations are

– The law of linear resistance

$$(1) \quad q = kD \frac{\partial \varphi}{\partial x}$$

– The law of continuity

$$(2) \quad \frac{\partial q}{\partial x} = \frac{k'}{D'} \varphi$$

In these equations t does not appear explicitly, although q and φ are functions of time.

It is assumed that the solution has the following form

$$\varphi = \varphi_0 e^{ax} \sin \omega t$$

$$q = q_0 e^{ax} \sin (\omega t + \beta)$$

to be written as

$$q = q_0 e^{ax} (\sin \omega t \cos \beta + \cos \omega t \sin \beta)$$

These formulas must be verified by substitution in the differential equations (1) and (2), at which occasion the values of a and β are found.

Substitution gives as conditions

– The cosine terms of (1) and (2): $\sin \beta = 0$

– The sine terms of (1):

$$\frac{q_0}{a} = \frac{kD\varphi_0}{\cos \beta}$$

- The sine terms of (2):

$$q_0 a = \frac{k'D'\varphi_0}{\cos \beta}$$

The solution $\sin \beta = 0$, $\beta = \pi$, $\cos \beta = -1$ corresponds to the right-hand part of the aquifer; the solution $\sin \beta = 0$, $\beta = 0$, $\cos \beta = +1$ to the left-hand part. In either case q_0 and a can be calculated from their ratio and their product.

These formulas express the following properties (considering the right-hand part of the aquifer):

- In any section, φ as well as q vary around zero as a sine function of time.
- The amplitudes of φ and q both decrease proportionally to e^{ax} (where a is negative).

Their ratio at the canal

$$\frac{q_0}{\varphi_0} = \sqrt{kD k'/D'}$$

is conserved in all sections. Both amplitudes vanish at infinite distance from the canal.

- Since in the expressions for φ and q the argument of the sine function is independent of x , the propagation of the waves is instantaneous, although damped.

5.2.3 Scheme C (confined aquifer)

Figure 50. - The formula for φ at both sides of the canal is the same as for the canal:

$$\varphi = \varphi_0 \sin \omega t$$

while

$$q = 0$$

The proof is given by substitution in the differential equations

- The law of linear resistance:

$$q = kD \frac{\partial \varphi}{\partial x}$$

- The law of continuity:

$$\frac{\partial q}{\partial x} = 0$$

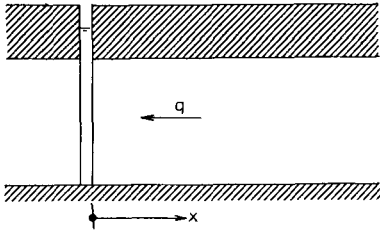

Fig. 50

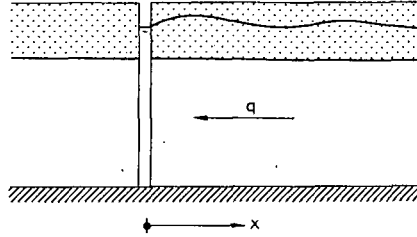

Fig. 51

These formulas represent the instantaneous and not damped propagation of pressure variations in stagnant water. This extreme result is due to the basic assumptions, which exclude elasticity and inertia:

5.2.4 Scheme D (partly confined aquifer with varying φ')

Figure 51. - The formulas are:

- (1) $\varphi = \varphi_0 e^{ax} \sin(\omega t + bx)$
- (2) $\varphi' = \varphi'_0 e^{ax} \sin(\omega t + bx + \alpha)$
- (3) $q = q_0 e^{ax} \sin(\omega t + bx + \beta)$

where φ_0 , φ'_0 and q_0 are positive; the sign of φ , φ' or q varies with the sign of the corresponding sine function.

As to the constants, α is defined by

$$(4) \quad \operatorname{tg}(-\alpha) = \frac{\mu' \omega}{k' D'}$$

where $0 < (-\alpha) < \frac{2\pi}{4}$. The limit values $-\alpha = 0$ and $-\alpha = \frac{2\pi}{4}$ will be studied separately.

β is determined by

$$(5) \quad \operatorname{tg} 2\beta = \frac{k' D'}{\mu' \omega} \quad (= \operatorname{cotg}(-\alpha))$$

- For the right-hand part of the aquifer

$$\frac{2\pi}{2} < \beta < \frac{5}{8} 2\pi.$$

Both $\sin \beta$ and $\cos \beta$ are negative.

– For the left-hand part of the aquifer

$$0 < \beta < \frac{1}{8} 2\pi.$$

Both $\sin \beta$ and $\cos \beta$ are positive.

φ'_0 is determined by

$$(6) \quad \varphi'_0 = \varphi_0 \cos \alpha$$

where $\cos \alpha$ ($= \cos(-\alpha)$) is always positive.

q_0 is defined by

$$(7) \quad q_0 = \varphi_0 \sqrt{\mu' \omega k D \cos \alpha},$$

positive by definition.

a is defined by

$$(8) \quad a = \frac{q_0}{\varphi_0 k D} \cos \beta = \sqrt{\frac{\mu' \omega \cos \alpha}{k D}} \cos \beta$$

where a has the same sign as $\cos \beta$.

b is defined either by

$$(9) \quad b = \frac{q_0}{\varphi_0 k D} \sin \beta = \sqrt{\frac{\mu' \omega \cos \alpha}{k D}} \sin \beta$$

or by

$$b = a \operatorname{tg} \beta$$

where $\sin \beta$, $\cos \beta$, a and b have the same sign, and $\operatorname{tg} \beta$ is always positive.

The differential equations are:

– The law of linear resistance

$$(10) \quad q = kD \frac{\partial \varphi}{\partial x}$$

– The law of continuity:

$$(11) \quad \frac{\partial q}{\partial x} = \mu' \frac{\partial \varphi'}{\partial t} = \frac{k'}{D'} (\varphi - \varphi')$$

These three differential equations define φ , φ' and q as functions of x and t .

Formulas (1), (2) and (3) are admitted tentatively as a solution, with unknown values of α , β , φ'_0 , q_0 , a and b . From them $\partial\varphi/\partial x$, $\partial q/\partial x$ and $\partial\varphi'/\partial t$ are derived by differentiation. Substitution in (10) and (11) gives separate conditions for the sine and cosine terms, a total of six.

$$(12) \quad a = \frac{q_0}{\varphi_0 k D} \cos \beta$$

$$(13) \quad b = \frac{q_0}{\varphi_0 k D} \sin \beta$$

$$(14) \quad q_0(a \cos \beta - b \sin \beta) = -\mu' \varphi'_0 \omega \sin \alpha = \frac{k'}{D'} (\varphi_0 - \varphi'_0 \cos \alpha)$$

$$(15) \quad q_0(b \cos \beta + a \sin \beta) = \mu' \varphi'_0 \omega \cos \alpha = -\frac{k'}{D'} \varphi'_0 \sin \alpha$$

These six equations define the six constants α , β , φ'_0 , q_0 , a and b .

Substituting the values of a and b from (12) and (13) into (14) and (15) gives:

$$(16) \quad \frac{q_0^2}{\varphi_0 k D} \cos 2\beta = -\mu' \varphi'_0 \omega \sin \alpha = \frac{k'}{D'} (\varphi_0 - \varphi'_0 \cos \alpha)$$

$$(17) \quad \frac{q_0^2}{\varphi_0 k D} \sin 2\beta = \mu' \varphi'_0 \omega \cos \alpha = -\frac{k'}{D'} \varphi'_0 \sin \alpha$$

From the last two members of (17)

$$(18) \quad \operatorname{tg} \alpha = -\frac{\mu' \omega}{k'/D'}$$

From the first members of (16) and (17)

$$(19) \quad \operatorname{tg} 2\beta = \frac{k'/D'}{\mu' \omega}$$

From the last members of (14) and (15)

$$\operatorname{tg} \alpha = \frac{\varphi_0 - \varphi'_0 \cos \alpha}{\varphi'_0 \sin \alpha}$$

written otherwise:

$$(20) \quad \varphi'_0 = \varphi_0 \cos \alpha$$

From (18) it follows that $\operatorname{tg}(-\alpha)$ is positive; from (20) that $\cos(-\alpha)$ is positive.

Thus $0 < -\alpha < \frac{2\pi}{4}$. From the first two members of (16), since $\sin \alpha$ is negative, it

follows that $\cos 2\beta$ is positive; from the corresponding members of (17) that $\sin 2\beta$ is positive, thus $0 < 2\beta < 2\pi/4$ and $0 < \beta < 2\pi/8$. This condition applies to the left-hand part of the aquifer. But since the limits of 2β may be increased by 2π , those of β may be increased by $2\pi/2$. Thus a second range for β is found:

$$\frac{2\pi}{2} < \beta < \frac{5}{8} 2\pi, \text{ applying to the right-hand part of the aquifer.}$$

– For the right-hand part of the aquifer $\sin \beta$ and $\cos \beta$ are negative; thus, according to (8) and (9), a and b are negative. e^{ax} decreases with increasing x , i.e. towards the right.

– For the left-hand part $\sin \beta$ and $\cos \beta$ are positive; a and b are positive, e^{ax} decreases with increasing x , i.e. towards the left.

The characteristics of flow system D may be summarized as follows (for the right-hand part of the aquifer).

– In the canal, as well as in any section of the aquifer, φ and φ' vary around the zero value. The flow rate q varies equally around zero, which means that the water moves alternately in both directions, without any net displacement resulting.

– The amplitudes of φ , φ' and q are in the same ratio to each other in all sections of the aquifer. They are commonly multiplied by a factor e^{ax} , which decreases with increasing distance to the canal and vanishes at infinity.

– At the canal border φ' lags behind φ by a difference in phase varying from zero to $1/4 T$, depending on the constants of the system, whereas q is in advance of φ by a difference varying from $1/2 T$ to $5/8 T$.

– In a section at distance x from the canal the phases of φ , φ' and q still have the same differences, but are commonly delayed by bx . This characteristic corresponds to the notion of waves propagating with a velocity $c = \omega/b$.

5.2.5 Reduction of scheme D to scheme A (phreatic aquifer)

If in a marginal case

$$\frac{\mu' \omega}{k' D'} = \operatorname{tg}(-\alpha) \rightarrow 0$$

it follows that

$$\frac{\varphi'_0}{\varphi_0} = \cos(-\alpha) \rightarrow 1$$

which means that the amplitude of φ' approaches that of φ . This condition may correspond to different physical characteristics of the scheme, all resulting in the same effect that the losses of energy in the top layer due to the vertical velocity components become negligible.

- High values of k' . - When k' increases infinitely, the top layer assumes the character of the aquifer, in which the losses of energy due to the vertical velocity components are neglected by assumption. Thus the aquifer becomes phreatic.
- Low values of μ' . - When μ' decreases, the water transport through the top layer in vertical direction, corresponding to a given displacement of the water level, decreases, and vanishes when $\mu' \rightarrow 0$. Thus, for given value of k' , the corresponding losses of energy vanish, which renders the flow system similar to that of a phreatic aquifer.
- Low values of ω . - Since $T = 2\pi/\omega$, this condition corresponds to very slow oscillations, where the vertical water transport in the top layer causes low velocities with negligible losses of energy, which again leads to analogy with the phreatic aquifer.

As a further consequence, according to (7)

$$q_0 \rightarrow \varphi_0 \sqrt{\mu' \omega k D}$$

where μ' has been written for the effective porosity, which in the case of a phreatic aquifer may be indicated by μ .

Finally $\operatorname{tg}(-\alpha) \rightarrow 0$ corresponds to $\beta \rightarrow \frac{5}{8} 2\pi$ (at the right-hand side of the canal), which in turn corresponds to

$$\sin \beta \text{ as well as } \cos \beta \rightarrow -\frac{1}{2} \sqrt{2}; \quad a \text{ as well as } b \rightarrow -\sqrt{\frac{\mu' \omega}{2kD}}$$

5.2.6 Reduction of scheme D to scheme B (partly confined aquifer, $\varphi' = 0$)

If in another marginal case

$$\frac{k'/D'}{\mu' \omega} = \operatorname{cotg}(-\alpha)$$

is small, but not zero, it follows that

$$\frac{\varphi'_0}{\varphi_0} = \cos(-\alpha) \rightarrow \frac{k'/D'}{\mu' \omega}$$

As in the previous section, this condition may correspond to different physical characteristics, all resulting in the same effect that the amplitude of φ' becomes negligible compared with that of φ .

- Low values of k' , which strongly damp the oscillations of φ' .
- High values of ω , corresponding to rapid oscillations of φ , which cannot be followed by the water table.

– High values of μ' would give the same effect, but μ' is limited by the maximum values of the effective porosity in natural soils.

Substituting $\cos \alpha = \frac{k'/D'}{\mu'\omega}$ in (7), where μ' cancels out:

$$q_0 = \varphi_0 \sqrt{kD \cdot k'/D'}$$

According to (5)

$$\operatorname{tg} 2\beta = \frac{k'/D'}{\mu'\omega}$$

For small values of the right-hand side of the equation, 2β is (near zero or) near 2π , and β near π , while $\sin \beta$ is about $-\frac{k'/D'}{\mu'\omega}$ and $\cos \beta$ near -1 .

According to (8), for $\cos \alpha \rightarrow \frac{k'/D'}{\mu'\omega}$, $a \rightarrow -\sqrt{\frac{k'/D'}{kD}}$

According to (9), $b = a \operatorname{tg} \beta$. Since $\operatorname{tg} \beta$ is small, $|bx|$ is small compared with $|ax|$. As was shown in the analysis of Scheme A, values of $|ax| > \pi$ are of little interest, because $e^{-\pi}$ reduces to about 4% only. Thus bx is only a fraction of π , and can be neglected as a difference in phase.

5.2.7 Reduction of scheme D to scheme C (confined aquifer)

If finally

$$\frac{k'/D'}{\mu'\omega} = \cotg(-\alpha) = 0$$

it follows that

$$\cos(-\alpha) = 0$$

and therefore

$$\varphi'_0 = \varphi_0 \cos(-\alpha) = 0$$

This condition corresponds to $k' = 0$. The top layer is impermeable; the phreatic level does not react on the variations of φ .

According to (7)

$$q_0 = \varphi_0 \sqrt{\mu'\omega kD \cos \alpha}$$

also $q_0 = 0$, which corresponds to the propagation of pressure waves through stagnant water.

Since $\varphi' = 0$ and $q = 0$, the only formula remaining is that for φ :

$$\varphi = \varphi_0 e^{ax} \sin(\omega t + bx)$$

where $a = b = 0$ (according to (8) and (9) both are proportional to q_0 , which is zero), thus with $a = 0$ the waves are not damped, and with $b = 0$ the propagation is instantaneous.

5.3 SUPERPOSED SINUSOIDAL WAVES (PARALLEL FLOW)

The assumptions underlying the following sections are much the same as those of Section 5.2.1. In both cases parallel flow is assumed in a phreatic aquifer with constant D and $n = 0$. The difference is in the boundary conditions. Whereas in Section 5.2.1. the aquifer was bounded at one side by a canal where

$$\varphi = \varphi_0 \sin \omega t,$$

in the following sections it is bounded at both sides. The formulas will be found by applying the principle of superposition, taking the formulas of Section 5.2.1 as a base. These will be repeated here in a slightly different formulation, which is more practical for the purpose.

Writing α for the absolute value of a , and u for the absolute value of the distance between the canal and the point in question, while q remains positive when directed to the left, the formulas become:

For waves propagating in both directions:

$$\varphi = \varphi_0 e^{-\alpha u} \sin(\omega t - \alpha u)$$

For waves propagating to the right:

$$q = -q_0 e^{-\alpha u} \sin\left(\omega t + \frac{2\pi}{8} - \alpha u\right)$$

For waves propagating to the left:

$$q = q_0 e^{-\alpha u} \sin\left(\omega t + \frac{2\pi}{8} - \alpha u\right)$$

where

$$q_0 = \varphi_0 \sqrt{\mu \omega k D} = \varphi_0 \alpha k D \sqrt{2}; \alpha = \sqrt{\frac{\mu \omega}{2kD}}$$

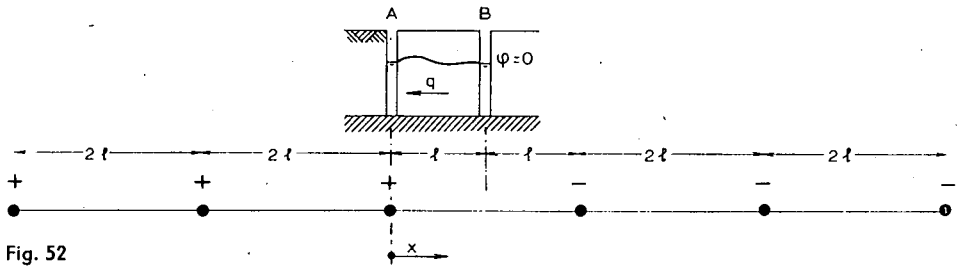

Fig. 52

5.3.1 Constant φ as a boundary condition

Figure 52. – The problem is to describe the water movement between the canals A and B, if in A the potential is a sine function of time

$$\varphi = \varphi_0 \sin \omega t,$$

and in B constant, equal to zero.

The solution can be found by superposing an infinite series of schemes similar to that of Section 5.2.1., each characterized by one canal sited in an infinite aquifer, while the potential in the canal varies according to

$$\varphi = \varphi_0 \sin \omega t$$

if the canal is marked with a plus sign in the figure, and to

$$\varphi = -\varphi_0 \sin \omega t$$

if marked with a minus sign.

The solution is

$$\varphi = \varphi_0 \sum p e^{-\alpha u} \sin (\omega t - \alpha u)$$

$$q = q_0 \sum s e^{-\alpha u} \sin \left(\omega t + \frac{2\pi}{8} - \alpha u \right)$$

where in the different terms successively

$p = +1,$	$s = -1,$	$u = x$
-1	-1	$2l - x$
$+1$	-1	$2l + x$
-1	-1	$4l - x$
$+1$	-1	$4l + x$
-1	-1	$6l - x$
$+1$	-1	$6l + x$

etc.

$$q_0 = \varphi_0 \sqrt{\mu \omega k D} = \varphi_0 \alpha k D \sqrt{2}; \alpha = \sqrt{\mu \omega / 2 k D}$$

The proof follows from the fact that the figure represents symmetry with opposite signs as to both canal axes, so that in canal B all φ variations counterbalance each other in pairs, whereas in canal A the variations in the canal itself remains as the only influence.

In principle another method can be followed, which may be preferable if the series converges slowly. If the summation is restricted to the first two terms, the condition $\varphi = 0$ in canal B is satisfied, but φ in canal A would be

$$\varphi = \varphi_0 \sin \omega t - \varphi_0 e^{-2\alpha l} \sin (\omega t - 2\alpha l)$$

which is not the true boundary condition

$$\varphi = \varphi_0 \sin \omega t$$

but can be written in the form of a single sine function

$$\varphi = c_1 \varphi_0 \sin (\omega t + c_2)$$

Thus the formulas for φ and q as functions of x and t , found by summing only the first two terms, can be adjusted by dividing the values of φ and q by c_1 , and delaying their phases by c_2 . The determination of c_1 and c_2 may be done analytically or graphically.

5.3.2 $q = 0$ as a boundary condition

Figure 53. - The model is similar to that of the previous section. In canal A, φ varies in the same way, according to

$$\varphi = \varphi_0 \sin \omega t$$

Fig. 53

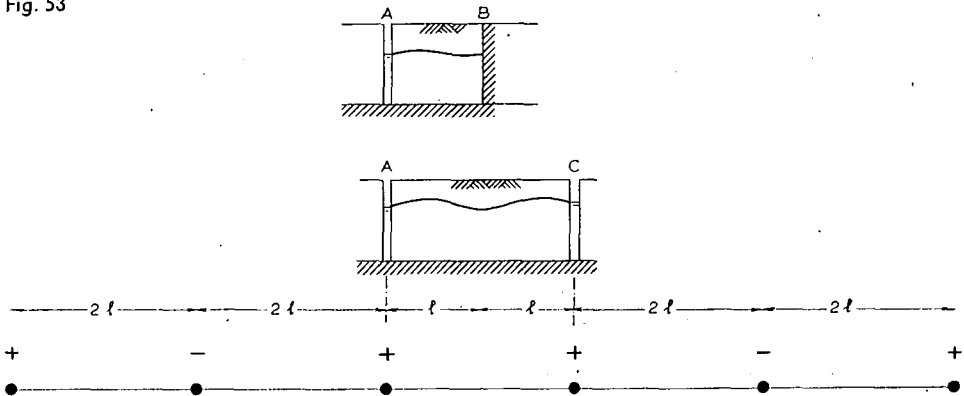

but the boundary condition on line B is

$$q = 0$$

This mathematical condition physically represents either an impermeable boundary, as indicated in the upper part of the figure, or the symmetry axis of an aquifer where in canal C, φ varies in the same way as in A, as indicated in the lower part of the figure.

The solution can be found in the same way as in the previous section by superposition of an infinite number of systems, each characterized by a single canal in an infinite aquifer. The variations of φ in these canals are equal or opposite to those in canal A, according to the plus or minus sign in the figure.

The solution can be expressed in the form of a series

$$\begin{aligned} \varphi &= \varphi_0 \sum p e^{-\alpha u} \sin(\omega t - \alpha u) \\ q &= q_0 \sum s e^{-\alpha u} \sin\left(\omega t + \frac{2\pi}{8} - \alpha u\right) \end{aligned}$$

where in the different terms successively

$$\begin{array}{ccc} p = +1, & s = -1, & u = x \\ +1 & +1 & 2l - x \\ -1 & +1 & 2l + x \\ -1 & -1 & 4l - x \\ +1 & -1 & 4l + x \\ +1 & +1 & 6l - x \\ -1 & +1 & 6l + x \\ & & \text{etc.} \end{array}$$

$$q_0 = \varphi_0 \sqrt{\mu\omega k D} = \varphi_0 \alpha k D \sqrt{2}; \quad \alpha = \sqrt{\mu\omega/2kD}$$

The proof follows from the fact that the figure represents symmetry with respect to line B, which implies $q = 0$ in B. The symmetry with opposite signs about line A means that the influence of all canals on the φ value in A cancel out in pairs, with the exception of the influence of the canal itself.

As in the previous section the summation may be restricted to the first two terms, and the result adjusted in the way indicated.

5.3.3 Periodic variations in recharge

Figure 54 represents a cross-section of a strip of land or an elongate island. The

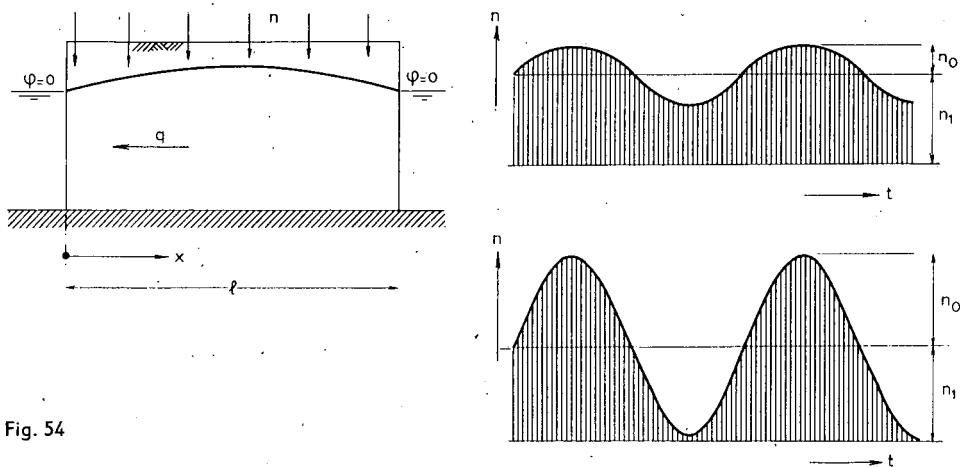

Fig. 54

potential φ of the (fresh) water at both sides is constant, equal to zero. The recharge n varies as a cosine function of time, according to

$$n = n_1 + n_0 \cos \omega t$$

If the period is one year, this formula may represent seasonal variations in the recharge. The figure shows these variations in two different suppositions: for a n_0 value relatively small compared with n_1 , and for $n_0 = n_1$, which may correspond to the alternation of wet and dry seasons.

The solution (System IV) is found by superposition of three elementary systems, I, II and III.

System I is characterized by

- constant recharge n_1 , and
- potentials $\varphi = 0$ at both sides.

These conditions describe a steady flow system, as was examined in Section 2.2.1.

The formulas are:

$$\varphi = \frac{n_1}{2kD} x(l-x); \quad q = n_1 \left(\frac{l}{2} - x\right)$$

System II is characterized by

- recharge $n = n_0 \cos \omega t$, and
- potential variations at both sides

$$\varphi = \frac{n_0}{\mu\omega} \sin \omega t$$

The recharge $n = n_0 \cos \omega t$, if represented physically, would correspond to an alter-

nation of recharge and evaporation. If such alternations occurred in an aquifer extending in all directions to infinity; they would create uniform oscillations of the water level, corresponding to variations in φ defined by

$$\frac{d\varphi}{dt} = \frac{1}{\mu} (n_0 \cos \omega t)$$

or upon integration

$$\varphi = \frac{n_0}{\mu\omega} \sin \omega t$$

If the aquifer were limited, but the water level at both sides varied in the same way, the level in the aquifer would also move up and down as a horizontal plane, according to the given formulas, and no lateral flow would occur:

$$q = 0$$

System III is characterized by

- recharge $n = 0$, and
- variations of φ at both sides according to

$$\varphi = -\frac{n_0}{\mu\omega} \sin \omega t$$

so as to counterbalance the movements introduced in System II. The formulas of System III have been given in the preceding section for a distance $2l$ between the canals instead of l .

Thus, by summing the equations of the three elementary systems, those of System IV are obtained:

$$\varphi = \frac{n_1}{2kD} x(l-x) + \frac{n_0}{\mu\omega} \sin \omega t - \frac{n_0}{\mu\omega} \sum p e^{-\alpha u} \sin(\omega t - \alpha u)$$

$$q = n_1 \left(\frac{l}{2} - x \right) - \frac{n_0}{\alpha\sqrt{2}} \sum s e^{-\alpha u} \sin \left(\omega t + \frac{2\pi}{8} - \alpha u \right)$$

where $\alpha = \sqrt{\frac{\mu\omega}{2kD}}$, and in the terms successively:

$p = +1,$	$s = -1,$	$u = x$	$+1$	-1	$2l + x$
$+1$	$+1$	$l - x$	$+1$	$+1$	$3l - x$
-1	$+1$	$l + x$	-1	$+1$	$3l + x$
-1	-1	$2l - x$	etc.		

5.4 SUDDEN CHANGE IN BOUNDARY CONDITION. PARALLEL FLOW

5.4.1 Basic formulas

Figure 55. – Again in this section the systems are characterized by parallel flow in a phreatic aquifer with constant D , and $n = 0$. The aquifer is bounded on the left by a canal, and extends infinitely to the right. The water movement is discontinuous at the moment $t = 0$. Before that moment, the aquifer was at rest ($\varphi = 0, q = 0$).

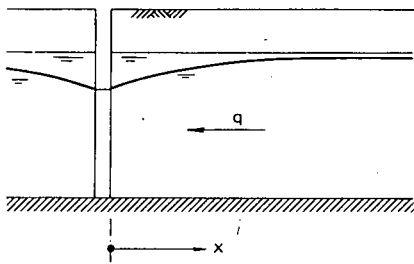

Fig. 55

From that moment onwards it is under the influence of a given variation in the canal, defined either as

$$\varphi = c_1 t^m$$

or as

$$q = c_2 t^{m-1/2}$$

where c_1 and c_2 are constants, and m a parameter.

The series of solutions to be examined (depending on the parameter m) can be written in the form

$$(1) \quad \varphi = t^m f(u),$$

$$(2) \quad q = a t^{m-1/2} f'$$

$$\text{where } u = \frac{1}{2} \sqrt{\frac{\mu}{kD}} \frac{x}{\sqrt{t}}, \quad a = \frac{1}{2} \sqrt{\mu k D} \text{ and } f' = \frac{df}{du}$$

The function $f(u)$ is a solution of the linear differential equation

$$f'' + 2uf' - 4mf = 0$$

for the conditions

$$\text{for } u = \infty, \quad f = 0$$

$$\text{for } u = 0, \quad f = c$$

The differential equations are:

- The law of linear resistance

$$(3) \quad q = kD \frac{\partial \varphi}{\partial x}$$

- The law of continuity:

$$(4) \quad \frac{\partial q}{\partial x} = \mu \frac{\partial \varphi}{\partial t}$$

- The solution

$$(1) \quad \varphi = t^m f(u)$$

is to be checked by substitution into the differential equations (3) and (4). Differentiating (1) with respect to x and substituting in (3) yields

$$(2) \quad q = at^{m-1/2} f'$$

Differentiating (2) with respect to x gives

$$\frac{\partial q}{\partial x} = \frac{a^2}{kD} t^{m-1} f''$$

Differentiating (1) with respect to t gives

$$\frac{\partial \varphi}{\partial t} = t^{m-1} \left(mf - \frac{1}{2} uf' \right)$$

When these values are substituted in (4) the result can be written in terms of f and u only, which confirms that the structure of formula (1) was right:

$$f'' + 2uf' - 4mf = 0$$

This differential equation relating f to u is of the second order. Its solution is defined by two conditions, for which are chosen:

- For $u = \infty$, $f = 0$

The value $u = \infty$ corresponds to $t = 0$ as well as to $x = \infty$, while $f = 0$ corresponds to $\varphi = 0$. Thus the above condition is the combined expression of the initial condition:

$$\text{for } t = 0, \quad \varphi = 0$$

and the boundary condition at infinite distance from the canal:

$$\text{for } x = \infty, \quad \varphi = 0$$

- For $u = 0$, $f = c$

The value $u = 0$ corresponds to $x = 0$ or $t = \infty$. Thus the condition expresses both

$$\text{for } x = 0 \quad \varphi = ct^m$$

which is the boundary condition at the canal, and

$$\text{for } t = \infty \quad \varphi = ct^m$$

The state at $t = \infty$ need not be considered here, since the basic assumption of the problem was that D is constant. Of any variation of φ in the canal, proportional to a power of t , only the first period is to be considered, when the level variation is negligible in comparison to D . The only exception is the case $m = 0$, where indeed

$$\text{for } t = \infty, \quad \varphi = ct^0 = c$$

(see below for the analysis of that case).

Four cases will be examined:

- $m = 0$. At $t = 0$ the potential in the canal is suddenly lowered, and kept constant from that moment onwards ($\varphi = c$).
- $m = 1/2$. From $t = 0$ onwards a constant rate is extracted from the canal ($q = c$).
- $m = 1$. From $t = 0$ onwards the potential in the canal is lowered at a constant rate ($\varphi = ct$).
- $m = 1.1/2$. From $t = 0$ onwards the water is extracted from the canal at an increasing rate, proportional to time ($q = ct$).

Table. - (see pag. 128).

The formulas of these four cases are given in the upper part of the table. The left-hand column gives φ and q as functions of x and t ; the right-hand column gives the same quantities as functions of time at the canal border ($x = 0$).

In the lower part of the table the left-hand column gives the definition of the functions f_0, f_1, f_2, f_3 and f_4 ; the right-hand column their values for $u = 0$. For $u = \infty$ all functions vanish. The relationship is such that

$$f_0 = f'_1, \quad f_1 = f'_2, \quad f_2 = f'_3, \quad f_3 = f'_4$$

where f' stands for df/du .

The formulas show that at any distance x from the canal, however great, a slight influence is felt, even shortly after the moment $t = 0$. This is due to the artificial conditions, elasticity and inertia of water and soil being neglected.

Figure 56. - The functional relationships are illustrated. The left-hand column gives φ as a function of x at four successive moments, chosen at equal intervals. The second and third column give respectively φ and q as functions of t at the canal ($x = 0$).

Figure 57. - Similar diagrams can be drawn for any value of x . As an example φ is given as a function of t for $m = 1/2$ in four sections a, b, c and d , chosen at equal distances, where a is the canal border. Each curve shows an inflection point P which is nearer to the origin of the coordinate system when x is smaller. For $x = 0$, P

Table

Aquifer	Canal	Aquifer	Canal
$m = 0$	$\varphi = -c_1$	$\frac{df_0}{du} = -2uf_0$	$\frac{df_0}{du} = 0$
$q = ac_1 t^{-1/2} f_0$	$q = \frac{2}{\sqrt{\pi}} ac_1 t^{-1/2}$	$f_0 = \frac{2}{\sqrt{\pi}} e^{-u^2}$	$f_0 = \frac{2}{\sqrt{\pi}}$
$m = 1/2$		$f_1 = -\left(1 - \frac{2}{\sqrt{\pi}} \int_0^u e^{-u^2} du\right)$	$f_1 = -1$
$\varphi = c_2 t^{1/2} f_2$	$\varphi = \frac{1}{\sqrt{\pi}} c_2 t^{1/2}$	$f_2 = \frac{f_0}{2} + uf_1$	$f_2 = \frac{1}{\sqrt{\pi}}$
$q = ac_2 f_1$	$q = -ac_2$	$f_3 = \frac{u}{4} f_0 + \left(\frac{u^2}{2} + \frac{1}{4}\right) f_1$	$f_3 = -\frac{1}{4}$
$m = 1$		$f_4 = \frac{u^2 + 1}{12} f_0 + \left(\frac{u^3}{6} + \frac{u}{4}\right) f_1$	$f_4 = \frac{1}{6\sqrt{\pi}}$
$\varphi = c_3 t f_3$	$\varphi = -\frac{1}{4} c_3 t$	$u = \frac{1}{2} \sqrt{\frac{\mu}{kD}} \frac{x}{\sqrt{t}}; a = \frac{1}{2} \sqrt{\frac{\mu kD}{t}}$	
$q = ac_3 t^{1/2} f_2$	$q = \frac{1}{\sqrt{\pi}} ac_3 t^{1/2}$		
$m = 1^{1/2}$			
$\varphi = c_4 t^{3/2} f_4$	$\varphi = \frac{1}{6\sqrt{\pi}} c_4 t^{3/2}$		
$q = ac_4 t f_3$	$q = -\frac{1}{4} ac_4 t$		

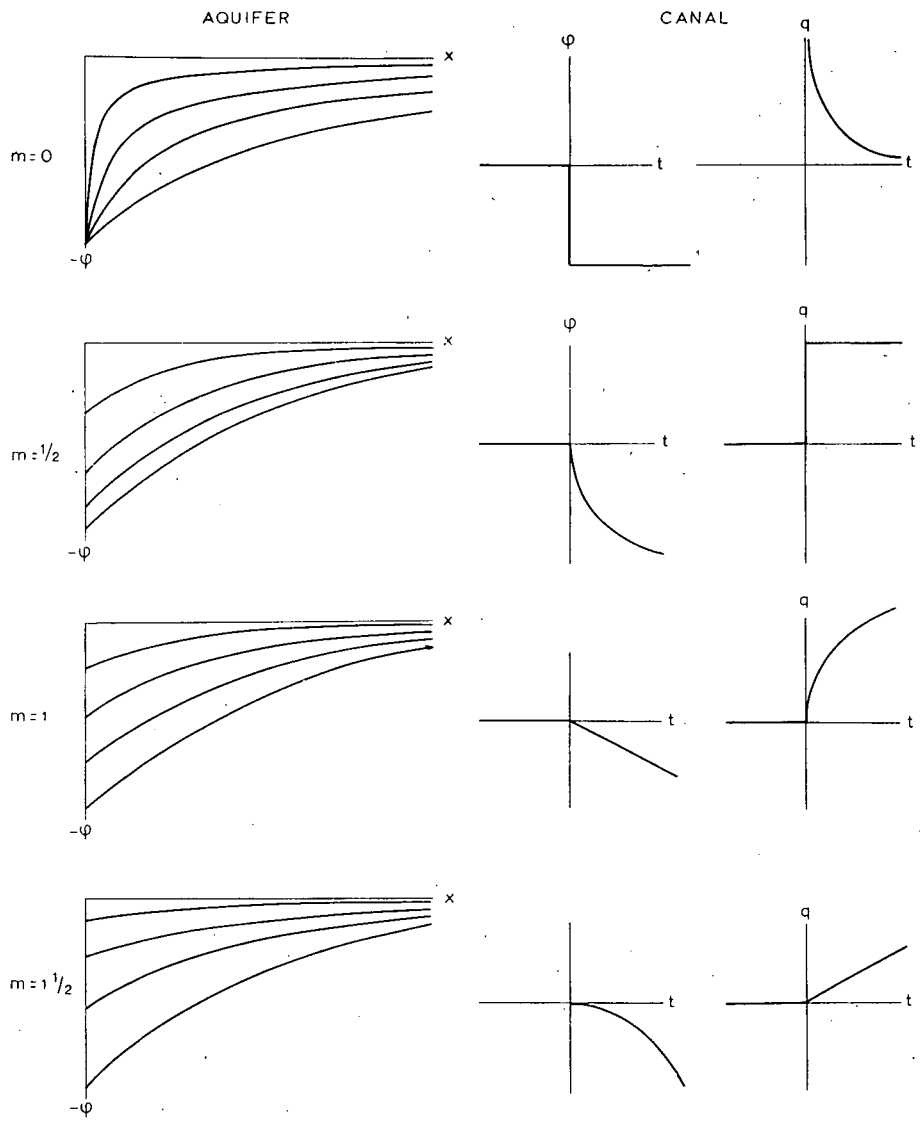

Fig. 56

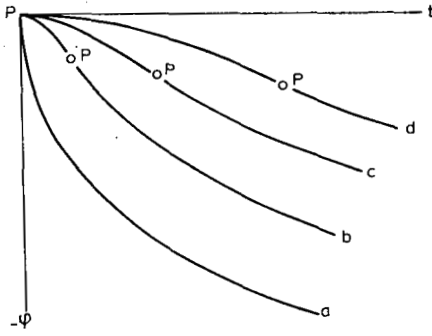

Fig. 57

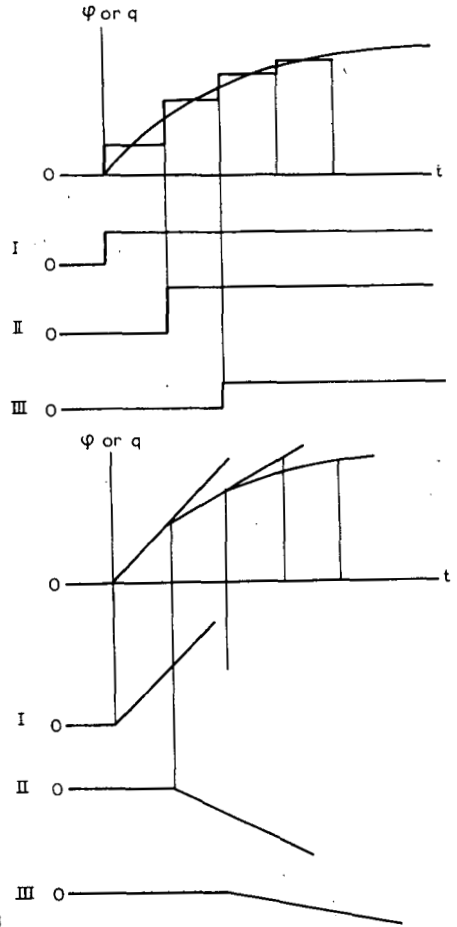

Fig. 58

coincides with the origin, and the tangent to the curve in the origin, which is horizontal for all curves, becomes vertical.

5:4.2 Superposed variations

Figure 58. - 1. Four examples will be given of superposition of elementary flow schemes.

1. In the model of the preceding section φ may vary in an arbitrary way with time, as indicated by the smooth curve in the figure. If this curve is replaced by a stepped curve, the latter can be considered as the sum of a great number of elementary systems of the type $m = 0$, as indicated in the upper group of diagrams. The same line of

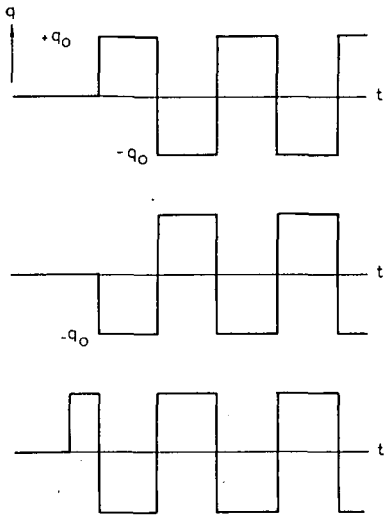

Fig. 59

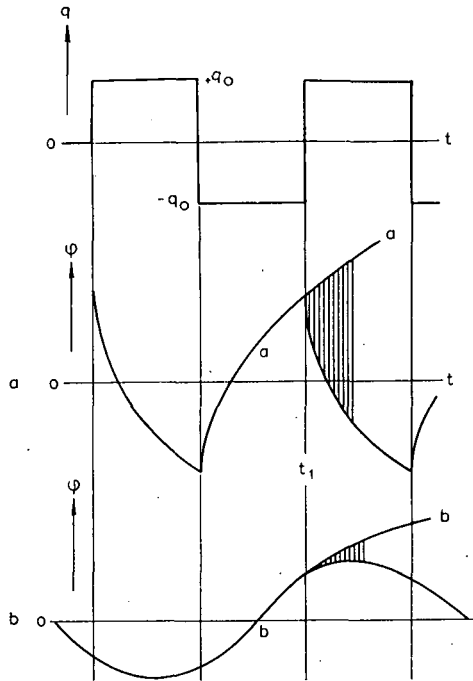

Fig. 60

thought can be followed if the diagrams represent q instead of φ as a function of t , in which case the solution can be reduced to schemes of the type $m = 1/2$.

Another approach is shown in the lower part of the figure, where the smooth curve is first replaced by a polygon, and then considered as the sum of a great number of schemes of the type $m = 1$ or $m = 1 1/2$, depending on whether variations of φ or q are given.

Figure 59. - 2. Instead of arbitrary variations, periodic changes may be studied, which correspond to such technical problems as daily or seasonal extraction from canals, or seasonal variations of river levels. As an example, a series of periods of equal length will be considered, during which alternately water is extracted from, or supplied to the canal, at equal rates. The quantity of flow thus passing through one of the sides of the canal is alternately $+q_0$ (during extraction) and $-q_0$ (during supply). Since the calculation must start from the initial state of rest, the first period may be one of either extraction or supply. The water movement at some distance from the canal will approach a regime of periodic repetition, but only after a certain number of phases. This state will be reached either from the low or the high side depending on whether the first period was one of extraction or supply. It can be reached more rapidly when a period of half length is assumed at the beginning, since at about the middle of each period the water level in the canal is nearest to its average height.

Figure 60. (Upper part). - The next considerations concern the state of periodic

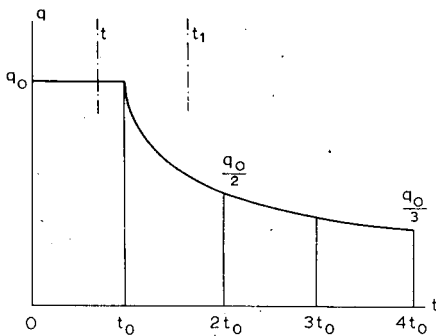

Fig. 61

repetition. In the canal, as long as water is supplied, the level rises; as soon as extraction begins it starts falling: the reaction is immediate. This is indicated in the middle figure, where, in the diagram of φ in the canal, the line aa represents the sum of all influences before $t = t_1$, while the shaded surface represents the influence of the extraction starting at $t = t_1$. Since the latter diagram is characterized by $\frac{\partial \varphi}{\partial t} = -\infty$ for $t = t_1$, the upward trend of the φ line immediately changes to a downward one when the extraction begins.

The diagram for a point at some distance from the canal (lower part of the figure) shows another character. Firstly the amplitudes are smaller: the waves are damped. Secondly there is a lag in phase: the moment when the sign of $\partial \varphi / \partial t$ changes is delayed. The reason for the latter particularity is shown in the figure, where the line bb represents the sum of all influences before $t = t_1$, and the shaded diagram the influence of the extraction beginning at $t = t_1$. In this case the latter diagram is characterized by a value $\partial \varphi / \partial t = 0$ for $t = t_1$, which means that the upward movement of the φ line does not change into a downward one until the negative value of $\partial \varphi / \partial t$ in the shaded diagram has become as great as the positive value of the line bb . (The form of the shaded diagram has been studied in Section 5.4.1.).

Thus a lag in phase exists, depending on the distance to the canal, similar to that described for sine variations in the canal (Section 5.2.1), but which does not correspond necessarily to a constant velocity. Anyhow the variations in steps of q at the base of this example are very near sinusoidal variations, and in orientating calculations the formulas of the sine functions may be taken, since they are more simple. The formulas of this section are useful in problems of less regular variations, e.g. periods of extraction and supply of different length.

Figure 61. - 3. In the above examples the variations in canal level were defined either in terms of φ or q . In the following example they will be expressed in terms of both

φ and q . Before the moment $t = 0$ the aquifer is at rest. From $t = 0$ to $t = t_0$ water is extracted from the canal, at a constant rate, corresponding to a flow q_0 through the side of the canal. From $t = t_0$ onwards the level in the canal is maintained at constant height. The problem is to assess the quantity of flow entering through the side of the canal after $t = t_0$ as a function of time.

Although the boundary condition between $t = 0$ and $t = t_0$ is given in terms of q as

$$q = q_0,$$

it can be translated in terms of φ by means of the formulas of the scheme $m = 1/2$.

$$(1) \quad \varphi = -\frac{q_0}{a\sqrt{\pi}} t^{1/2}, \quad a = \frac{1}{2}\sqrt{\mu k D}$$

This continuous variation of φ with time can be considered the succession of an infinite number of infinitely small variations $d\varphi$, where the value of $d\varphi$ follows from differentiation of (1)

$$2) \quad d\varphi = -\frac{q_0}{2a\sqrt{\pi}} t^{-1/2} dt$$

The flow dq through the side of the canal at a time t_1 ($t_1 > t_0$) caused by an elementary change in φ at the moment t ($0 < t < t_0$) is defined by the formulas of the system $m = 0$.

$$dq = -\frac{2a}{\sqrt{\pi}} (t_1 - t)^{-1/2} d\varphi$$

or, after substitution of the value of $d\varphi$ from (2)

$$dq = \frac{q_0}{\pi} t^{-1/2} (t_1 - t)^{-1/2} dt$$

Integration between the limits $t = 0$ and $t = t_0$ gives

$$q_1 = \frac{2}{\pi} q_0 \arcsin \sqrt{\frac{t_0}{t_1}}$$

where q_1 is the flow through the side of the canal at the moment t_1 .

Considering q_1 and t_1 as variables, written as q and t , the formula becomes:

$$q = \frac{2}{\pi} q_0 \arcsin \sqrt{\frac{t_0}{t}}$$

This function is represented in the figure. For $t = t_0$, $\partial q / \partial t = -\infty$; for $t = 2t_0$, $q = q_0/2$; for $t = 4t_0$, $q = q_0/3$.

4. If the aquifer, instead of extending to infinity, is bounded at the other side by a second canal where $\varphi = 0$, or by an impermeable wall, where $q = 0$, the problem can be solved by the method indicated in Section 5.3. for sinusoidal waves. The system is then the superposition of an infinite series of schemes, each characterized by a single canal, where the variations of either φ or q are equal or opposite to those in the first canal. Since the reasoning is the same, it will not be repeated here.

Another scheme, not mentioned here, since it is similar to that of Section 5.3.3, is the water movement in an island, created by a succession of dry and rainy seasons, each with uniform rainfall.

5.5 SUDDEN CHANGE IN BOUNDARY CONDITION. RADIAL FLOW

Figure 62. – This section treats the same problems as Section 5.4.1, but for radial instead of parallel flow. A well is sited in a phreatic aquifer with constant D , without recharge, extending in all directions to infinity. The aquifer is at rest until $t = 0$. From that moment onwards water is extracted from the well in such a way that

$$Q = ct^m$$

where c is a constant, and m a parameter.

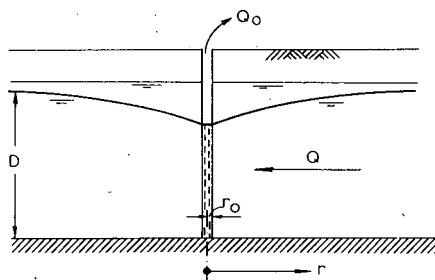

Fig. 62

The general form of the solution is very similar to that of parallel flow. It reads:

$$(1) \quad \varphi = t^m f(u)$$

$$(2) \quad Q = 2\pi k D t^m u f'(u)$$

where

$$u = \frac{1}{2} \sqrt{\frac{\mu}{kD}} \frac{r}{\sqrt{t}}$$

the same variable as used in the formulas of parallel flow. $f'(u)$ stands for df/du while $f(u)$ is the solution of the differential equation

$$f'' + f' \left(\frac{1}{u} + 2u \right) - 4mf = 0$$

for the conditions:

$$\text{for } u = \infty, \quad f = 0$$

$$\text{for } u = 0, \quad uf' = c_1$$

where c_1 is a constant.

The proof is essentially the same as in Section 5.4.1. The differential equations are:

- The law of linear resistance:

$$(3) \quad Q = 2\pi k D r \frac{\partial \varphi}{\partial r}$$

- The law of continuity:

$$(4) \quad \frac{\partial Q}{\partial r} = 2\pi \mu r \frac{\partial \varphi}{\partial t}$$

When taking

$$(1) \quad \varphi = t^m f(u)$$

substitution in (3) gives

$$(5) \quad Q = 2\pi k D t^m u f'$$

Differentiating (5) with respect to r results in

$$\frac{\partial Q}{\partial r} = 2\pi k D t^m \frac{u}{r} (f' + u f'')$$

Differentiating (1) with respect to t gives

$$\frac{\partial \varphi}{\partial t} = t^{m-1} \left(m f - \frac{1}{2} u f' \right)$$

When these values are substituted in (4), the result can be written in terms of f and u only

$$f'' + f' \left(\frac{1}{u} + 2u \right) - 4mf = 0$$

$f(u)$ must be a solution of this differential equation for the following two boundary conditions

- For $u = \infty, f = 0$

The value $u = \infty$ corresponds to both $t = 0$ and $r = \infty$, while $f = 0$ corresponds to $\varphi = 0$. The condition therefore combines the initial condition

$$\text{for } t = 0, \quad \varphi = 0$$

and the boundary condition at infinite distance

- for $r = \infty$, $\varphi = 0$
 - For $u = 0$, $uf' = c_1$

The value $u = 0$ stands with slight approximation for $r = r_0$ (where r_0 is the radius of the well). It is not certain beforehand whether this approximation is justified, since the function $f(u)$ shows a singularity for $u = 0$. The proof can be given afterwards, when the function $f(u)$ is determined, by showing that the value of uf' varies little for small values of u . The value $uf' = c_1$ corresponds to $Q = 2\pi k D c_1 t^m = ct^m$. Thus the condition stands for

$$\text{for } r = r_0, Q = ct^m$$

As in the problem of parallel flow, $u = 0$ corresponds to $t = \infty$ as well; but only a limited range of t will be considered, since the drawdown must be small in comparison with D , so as to be negligible.

Since the formulas of this section are more complicated than those for parallel flow, only the case $m = 0$ will be treated, which corresponds to extraction from the well at a constant rate Q_0 . It has already been pointed out that constant extraction in an infinite phreatic aquifer does not give rise to a steady flow system. The formulas below describe the nonsteady system. They are valid for a limited period of time only, since the condition must be satisfied that the drawdown in the well is small compared with the thickness of the aquifer.

The solution reads:

$$\varphi = \frac{Q_0}{4\pi k D} Ei(-v); \quad Q = Q_0 e^{-v}$$

where

$$Ei(-v) = \int_{\infty}^v \frac{e^{-v}}{v} dv = \ln(\gamma v) - v + \frac{v^2}{2!2} - \frac{v^3}{3!3} + \frac{v^4}{4!4} + \dots$$

$$\gamma = 1,781072\dots; \quad v = u^2 = \frac{\mu}{4kD} \frac{r^2}{t}$$

The formulas indicate that there is no radius of influence: the influence of the variation in the well is felt immediately at any distance, in a measure which varies with time. It vanishes at infinite distance. This result is due to the extreme assumption of inelastic soil and water and the absence of inertia forces.

Artificially a radius of influence can be defined as the distance R from the well where $Q < \alpha Q_0$, when α is an arbitrarily chosen small fraction, e.g. 5%. For this value $v = 3$

and $R^2 = \frac{12kD}{\mu} t$. For $\alpha = 10\%$, $v = 2,3$ and $R^2 = \frac{9.2kD}{\mu} t$. Thus R increases with \sqrt{t} . There is no constant velocity as regards the propagation of the front. Hence the term waves should preferably not be used. (Only the surface area of the circle enclosed by the radius R increases porportionally to t).

For small values of v , ($v < v_1$), the series can be reduced to its first term only. The formulas then become

$$\varphi = \frac{Q_0}{4\pi kD} \ln \gamma v; \quad Q = Q_0$$

The error introduced is 0,3% for $v = 0,01$, 5,3% for $v = 0,10$, 9,9% for $v = 0,15$ and 15.6% for $v = 0,20$. The approximation is valid for values of x and t bound by

$$v = \frac{\mu}{4kD} \frac{r^2}{t} < v_1$$

i.e. within a circle whose radius increases proportionally to \sqrt{t} . The constant value of Q indicates that the recharge within the circle is negligible compared with the flow entering laterally through its border. This circle extends with time because the lowering of the water table within it decreases with time. This is another example of a flow system where Q is constant in the vicinity of the well, which makes the relation between φ and r logarithmic (see Section 2.3.1).

The logarithmic relationship is valid in particular at the well face ($r = r_0$). Thus the drawdown in the well is given by

$$\varphi_0 = \frac{Q_0}{4\pi kD} \ln \left(\frac{\gamma \mu}{4kD} \frac{r_0^2}{t} \right)$$

The formulas established in this section may be useful for calculating the water movement created by periodic extraction from a well, alternating with periods of rest, as may occur in irrigation or drainage practice. When several wells are sited in an aquifer, their influences can be superposed by adding the values of φ or q . The extraction from the wells need not begin simultaneously. The aquifer may extend to infinity in all directions, or be limited by parallel canals, or by a canal and an impermeable wall. The way to handle these problems has been indicated in Sections 2.3.4 and 2.3.5.

6. TWO-FLUID SYSTEMS OF FRESH AND SALT WATER

6.1 FUNDAMENTALS

6.1.1 *Introduction*

In coastal regions, water infiltrating from rain or irrigation flows off underground towards the sea. This groundwater flow does not cover the total thickness of the aquifer, because the sea water, due to its greater specific weight, intrudes laterally into the lower part of the permeable strata. The slight difference of two to three percent in specific weight suffices to change entirely the characteristics of the flow pattern from those of a one-fluid system. Two distinct bodies of fresh and salt water form, one floating freely on the other.

Between the two bodies a transition layer of brackish water develops. The mechanism of its formation will be discussed later, as well as the reason why its thickness remains reduced (see Section 6.4). This layer is often thin compared with both the fresh and the salt water layer; its thickness may then be neglected, and a sharp interface assumed. This will be the assumption throughout this chapter. Because of its great technical importance, however, the behaviour of the transition layer under the influence of extraction from a well or gallery will be studied in Section 6.4.

Figure 63. – In steady flow, different cases may be distinguished, as indicated (all in a phreatic aquifer as an example).

Fig. a shows a cross-section of an island. The salt water is at rest since the sea level all around the island is the same. The fresh water body is not thick enough to reach the bottom of the aquifer; thus it is in contact with the salt water over the whole area.

Fig. b shows the same cross-section for a thicker water lens, resting on the imper-

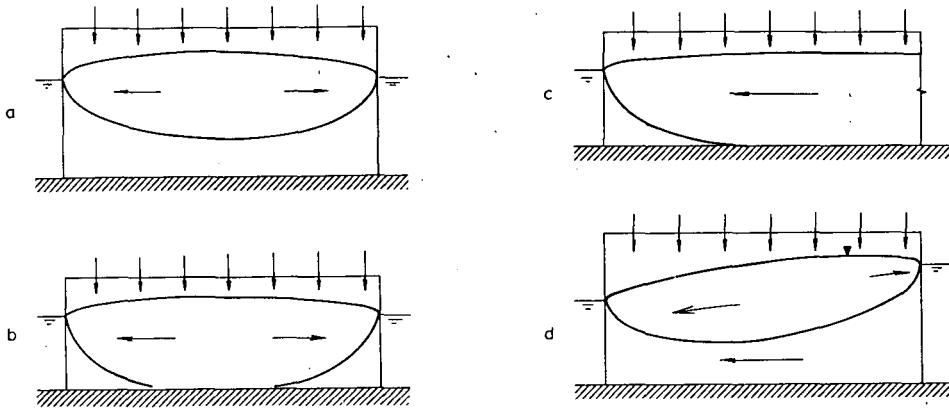

Fig. 63

meable base of the aquifer. An interface then exists only along the coast.

Fig. c. The same situation exists at the coast of a mainland, where at some distance from the shoreline the interface encounters the base of the aquifer.

Fig. d represents a cross-section of a strip of land, bounded at both sides by salt water of the same density, but at different levels. This situation is rare in nature but is easy to realize in a laboratory. Unlike the other examples, here not only the fresh water moves, but also the salt water.

Two-fluid systems may be steady or unsteady. Unsteady flow occurs on the one hand when one or more of the quantities determining the flow system vary with time, as in the case of tidal movement of the sea, variations of river levels, seasonal rainfall or periodic extraction from wells; and on the other hand when these quantities, although constant from a certain moment onwards, do not correspond to the form of the interface or the phreatic level at the initial moment. Then a gradual adaptation of the form of these surfaces leads, after theoretically infinite time, to a steady flow pattern.

The time needed for the adaptation of the interface is in general much longer than that of the phreatic water surface in a one-fluid system: it may cover tens or even hundreds of years. Unsteady flow is therefore the rule, rather than the exception in two-fluid systems. In coastal regions all over the world, where in the last century works have been executed for water extraction, irrigation or drainage, the flow is generally unsteady. Conversely, looking into the future, all technical projects should be studied from the viewpoint of an intervention creating long-lasting unsteady flow. Although steady flow is thus of less importance than unsteady, it will be studied first for didactic reasons.

6.1.2 *Water resources*

The question of the yield is more complicated for two-fluid systems than for one-fluid systems. The discussion, therefore, will be limited to an elementary model, that of an island, where the fresh water body is in contact with the salt water over the whole area. Thus two-fluid systems, as exist along the coasts of mainlands, are not considered. The question of the yield involves several problems, to be dealt with in this chapter.

– In Section 6.2.5. considerations on the yield are given by comparing different steady-state systems. The theoretical maximum extraction rate, equal to the recharge of the island, is obtained when the extraction takes place all along the coast. But such exploitation is usually avoided for fear of extracting water from the transition zone, which is here at shallow depth.

– In Section 6.2.8. the possibility is discussed of increasing the fresh water extraction from the centre of the island in steady flow conditions, by simultaneously extracting salt water to be disposed of to the sea. A theoretical solution is given, mainly for didactic purposes, since it will generally be uneconomic or technically unfeasible.

– Nonsteady flow conditions, as described in Section 6.3 are of particular importance for short-term exploitation, since the movement of the interface is slow. For a limited period high extraction rates can be realised, but these cannot be maintained in the long run. Since the quantities of water released by a rise of the interface are important, they also play a role in long-term exploitation.

– The storage capacity of the lens plays a role when the recharge or the extraction rate varies periodically. This problem is examined in Section 6.3.5. for varying recharge of a phreatic aquifer.

– The transition layer greatly hampers the extraction of fresh water. It is usually unavoidable that some water from the upper part of the transition layer is extracted along with the fresh water. Its density is scarcely higher than that of fresh water, so that it moves upwards almost as easily. Its salinity increases with the quantity extracted. Even small rates may make the extracted mixture unfit for consumption or irrigation. The problem is explained in Section 6.4.2., while Section 6.4.3. deals with the principle of extracting fresh and brackish water separately, and transporting the brackish water to the sea.

6.1.3 *The law of discontinuity at the interface*

Figure 64. – The interface constitutes a discontinuity for the potential as well as for the velocity. The law of discontinuity can be written either in terms of potential (Formula 1) or of velocity (Formula 2), as will be shown. In the figure, I represents the interface, R an arbitrarily chosen reference level, A and B two adjacent points sited at either side of the interface. In its first form the law of discontinuity relates the potentials φ and φ'' at these points:

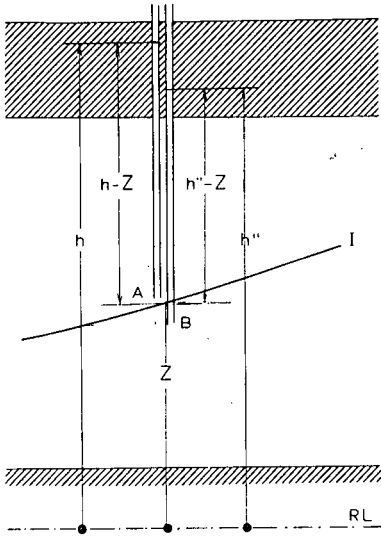

Fig. 64

$$(1) \quad \varphi - \varphi'' = -(\gamma'' - \gamma)Z$$

Often sea level is chosen as a reference level. Then Z is negative, and since $\gamma'' > \gamma$, $\varphi > \varphi''$

By definition of the potential at points A and B

$$\varphi = p + \gamma Z; \quad \varphi'' = p + \gamma'' Z$$

In both expressions p is the same, since the pressure is continuous at the interface.

Elimination of p gives (1).

If piezometers are installed at A and B, and filled with fresh and salt water respectively, their hydraulic heads are

$$h = \frac{\varphi}{\gamma} \quad \text{and} \quad h'' = \frac{\varphi''}{\gamma''}$$

related by

$$\frac{h - Z}{h'' - Z} = \frac{\gamma''}{\gamma}$$

Since $\gamma'' > \gamma$, $h - Z > h'' - Z$, which means that the water level rises higher in the fresh than in the salt water tube.

The common pressure p at A and B can be expressed either as $\gamma (h - Z)$ or as $\gamma'' (h'' - Z)$. Thus

$$\gamma (h - Z) = \gamma'' (h'' - Z) = p.$$

Figure 65. - In its second form the law of discontinuity is written in terms of velocities. The velocity component perpendicular to the interface is continuous:

$$u = u''$$

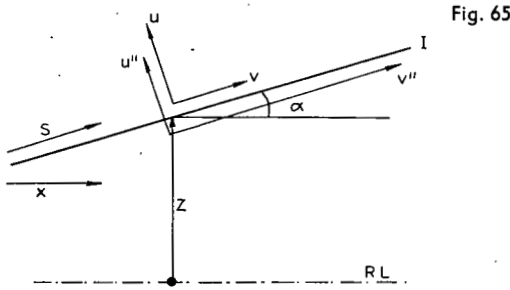

since the quantity $\frac{u}{m} = \frac{u''}{m}$ represents the velocity of displacement of the interface (where m is the effective pore space). In the case of steady flow the interface does not move:

$$u = u'' = 0$$

The velocity components parallel to the interface are related by

$$(2a) \quad v - v'' = k (\gamma'' - \gamma) \frac{\partial Z}{\partial s} = k (\gamma'' - \gamma) \sin \alpha$$

when isotropic soil is assumed, and

$$(2b) \quad v - v'' = k (\gamma'' - \gamma) \frac{\partial Z}{\partial x} = k (\gamma'' - \gamma) \tan \alpha$$

in the hypothesis of anisotropic soil with infinitely high permeability for vertical flow.

For isotropic soil, according to the law of linear resistance:

$$v = -k \frac{\partial \varphi}{\partial s} \text{ and } v'' = -k \frac{\partial \varphi''}{\partial s}$$

where s is the length coördinate along the interface. Partial derivatives are written since with nonsteady flow φ and φ'' may be functions of both s and t . The permeability is the same in fresh and salt water, if the slight difference in viscosity between the two fluids is neglected. (see Section 1.1.1.). Thus

$$v - v'' = k \frac{\partial(\varphi'' - \varphi)}{\partial s}$$

According to (1)

$$\varphi'' - \varphi = (\gamma'' - \gamma)Z$$

Differentiating with respect to s :

$$\frac{\partial(\varphi'' - \varphi)}{\partial s} = (\gamma'' - \gamma) \frac{\partial Z}{\partial s} = (\gamma'' - \gamma) \sin \alpha$$

which, upon substitution in the formula for $v - v''$, gives formula (2).

For anisotropic soil the proof is similar. The law of linear resistance reads:

$$v = -k \frac{\partial \varphi}{\partial x}; \quad v'' = -k \frac{\partial \varphi''}{\partial x}$$

while (1), upon differentiation with respect to x , gives

$$\frac{\partial(\varphi'' - \varphi)}{\partial x} = (\gamma'' - \gamma) \frac{\partial Z}{\partial x} = (\gamma'' - \gamma) \operatorname{tg} \alpha$$

From Equation (2) it can be concluded that if two fluids of different densities are in contact with each other along a sloping interface, they cannot both be at rest.

If $\alpha \neq 0$ and $\gamma'' \neq \gamma$, the right-hand side of (2) is different from zero and therefore v and v'' cannot both be zero.

The term 'dynamic equilibrium' is sometimes used for steady flow with sloping interface: the term 'equilibrium' indicating the steady position of the interface; the term 'dynamic' the movement of at least one of the fluids. It is, however, recommended to speak simply of steady flow.

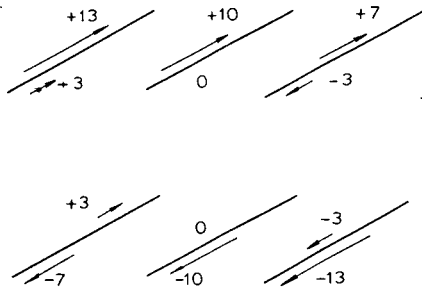

Fig. 66

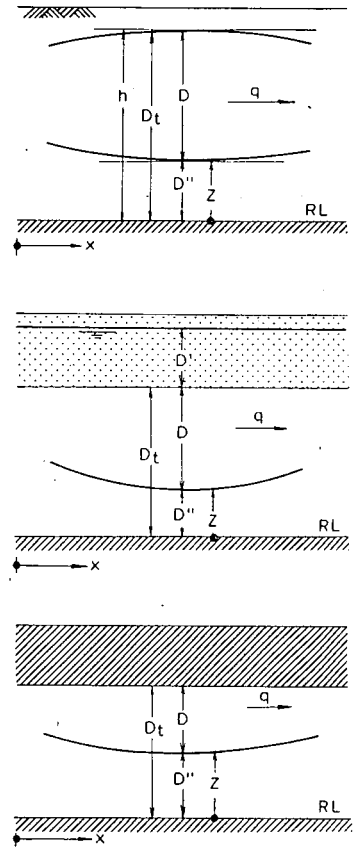

Fig. 67

Figure 66. — In Formula (2) v and v'' may have different signs. To illustrate the variety of possibilities, some examples are given in the figure, where schematically the quantity $k(\gamma'' - \gamma) \sin \alpha$ has been given the positive value of 10:

$$v - v'' = 10$$

It should be kept in mind that the law of discontinuity, either in form (1) or (2), is valid for nonsteady as well as for steady flow, this contrary to the laws of Section 6.2.3, which are restricted to steady flow with salt water at rest.

6.2 STEADY FLOW

6.2.1 Differential equations

Figure 67. — The general problem of steady flow involves the flow of both the salt and

the fresh water. The variables are related by five differential equations: the laws of linear resistance and continuity in both the fresh and the salt water bodies, and the law of discontinuity at the interface. These equations can be formulated as follows:

- The law of linear resistance in the fresh water:

$$(1) \quad q_x = -kD \frac{\partial \varphi}{\partial x} \quad q_y = -kD \frac{\partial \varphi}{\partial y}$$

- The law of linear resistance in the salt water:

$$(2) \quad q'_x = -kD'' \frac{\partial \varphi''}{\partial x} \quad q'_y = -kD'' \frac{\partial \varphi''}{\partial y}$$

- The law of continuity in the fresh water:

$$(3) \quad \frac{\partial q_x}{\partial x} + \frac{\partial q_y}{\partial y} = N$$

with in a phreatic aquifer $N = n$; in a partly confined aquifer $N = n = \frac{k'}{D'}(\varphi' - \varphi)$,

with φ' constant in case of steady flow; and in a confined aquifer $N = 0$.

- The law of continuity in the salt water:

$$(4) \quad \frac{\partial q'_x}{\partial x} + \frac{\partial q'_y}{\partial y} = 0$$

- The law of discontinuity at the interface.

$$(5) \quad \varphi - \varphi'' = -(\gamma'' - \gamma)Z$$

To these differential equations the following auxiliary relations must be added, where the reference level is assumed at the base of the aquifer.

- For a phreatic aquifer:

$$D'' = Z, \quad D = h - Z = \frac{\varphi}{\gamma} - Z$$

or, if as an approximation the total thickness of the fresh and salt water body is considered as a constant

$$D'' = Z, \quad D = D_t - Z$$

- For a confined or partly confined aquifer

$$D'' = Z, \quad D = D_t - Z$$

In the following sections it will be assumed that

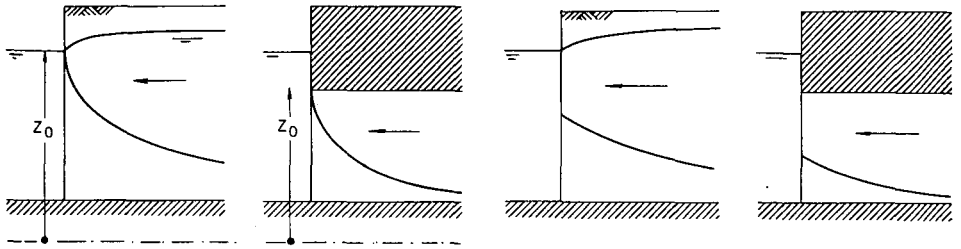

Fig. 68

- In a phreatic aquifer n is given as a function of x and y , independent of φ .
- In a partly confined aquifer either φ' or n is given as a function of x and y .

Under these conditions there are five unknown variables: φ , φ'' , q (q_x and q_y), q'' (q''_x and q''_y) and Z . Related to these by the auxiliary conditions are D and D'' , and in the case of a phreatic aquifer h . The five unknowns are defined by the five differential equations and the boundary conditions.

If the salt water is at rest, φ'' is a given constant, and $q''_x = q''_y = 0$. Thus the number of unknowns reduces to three: φ , (q_x and q_y) and Z . The number of differential equations reduces also to three, since the laws of linear resistance and of continuity in salt water disappear.

6.2.2 Boundary conditions

In a two-fluid system the boundary conditions are doubled with respect to one-fluid systems (see Section 1.3.3.). As an example a well may be assumed from which fresh water is extracted at a rate Q_0 . The double condition then reads:

$$Q = Q_0 \quad Q''_0 = 0$$

The second condition might easily be forgotten if one is merely thinking of the extraction of fresh water. Yet it establishes a condition, since, physically, extraction of both fresh and salt water is possible by placing in an uncased well two pumps whose orifices are respectively above and below the interface.

When water is extracted from a gallery, the same boundary conditions are valid

$$q = q_0 \quad q'' = 0$$

where q and q'' are the extraction rates per unit length of the gallery.

Figure 68. - In nearly all problems the boundary condition along the coast plays a role. The upper part represents the two alternatives: a phreatic aquifer or an aquifer with a covering layer (partly confined or confined). The fresh water layer always ends in a point. A vertical contact plane between fresh and salt water, as indicated in the

right part of the figure is not possible, as the pressure gradient $\partial p/\partial z$ would be different at either side of the plane (γ in the fresh water and γ'' in the salt water), whereas the pressure is continuous at the contact between fresh and salt water.

The double boundary condition is

$$\varphi'' = \varphi_0'' \quad Z = Z_0$$

where φ_0'' is the potential of the sea. If the aquifer is phreatic with reference level at sea level,

$$\varphi = \varphi'' = Z = 0$$

Near the coast the gradients of both h and Z tend to infinity, as shown in the figure. The same is true for the gradient of the fresh water potential.

The law of linear resistance in the fresh water

$$q = -kD \frac{\partial \varphi}{\partial x}$$

indicates that $\left| \frac{\partial \varphi}{\partial x} \right| \rightarrow \infty$ for $D \rightarrow 0$. In a phreatic aquifer $\left| \frac{\partial h}{\partial x} \right| \rightarrow \infty$, since $h = \frac{\varphi}{\gamma}$.

The law of discontinuity at the interface

$$v - v'' = k(\gamma'' - \gamma) \frac{\partial Z}{\partial x}$$

indicates that $\left| \frac{\partial Z}{\partial x} \right| \rightarrow \infty$ for $|v| \rightarrow \infty$ and v'' finite.

It is clear that near the coast, where the fresh-water velocities increase infinitely, a detailed study is required to establish whether the scheme is approximately representative of a physical flow system. This point is mentioned here, but will not be examined (see Section 3.2).

6.2.3 Basic laws for salt water at rest

If the fresh water is at rest, the level of the impermeable base is immaterial, provided the fresh water lense is in contact with the salt water over the whole area. If the fresh-water body is in contact with the impermeable base there is at least an interface in the vicinity of the coast. The relationships established below are valid for any aquifer or part of an aquifer where the fresh-water body is in contact with salt water at rest.

Distinction should be made between a phreatic aquifer on the one hand and a confined or a partly confined aquifer on the other. In both cases the reference level can be chosen at such an elevation that the thickness D of the fresh-water body is proportional to the fresh-water potential φ , which makes comparison with Chapter 3 possible, and allows for superposition. In this section the laws of proportionality will be studied first, then the comparison with Chapter 3 and the possibility of superposition will be examined.

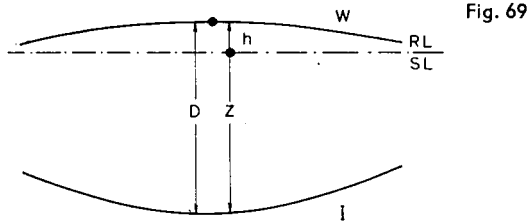

Figure 69. – If the aquifer is phreatic, the reference level is placed preferably at sea level. This makes $h'' = 0$ and therefore $\varphi'' = \gamma''$, $h'' = 0$; h becomes the elevation of the water surface above sea level and Z (negative) the depth of the interface below sea level.

Under this assumption the three quantities determining the shape of the fresh-water body, h , Z and D (where $D = h - Z$) are proportional to φ according to

$$h = \frac{\varphi}{\gamma} \quad -Z = \frac{\varphi}{\gamma'' - \gamma} \quad D = h - Z = \frac{\gamma''}{(\gamma'' - \gamma)} \frac{\varphi}{\gamma}$$

The relationship $h = \frac{\varphi}{\gamma}$, in combination with the law of discontinuity at the interface

$$\varphi - \varphi'' = \frac{\gamma}{\gamma'' - \gamma} (\gamma'' - \gamma) Z$$

gives for $\varphi'' = 0$ the indicated expressions for Z and D .

It follows from the above relationships that $-Z$ is proportional to h according to

$$-Z = \frac{\gamma}{\gamma'' - \gamma} h.$$

This is the well known law of Badon Ghijben-Herzberg. It states that the water

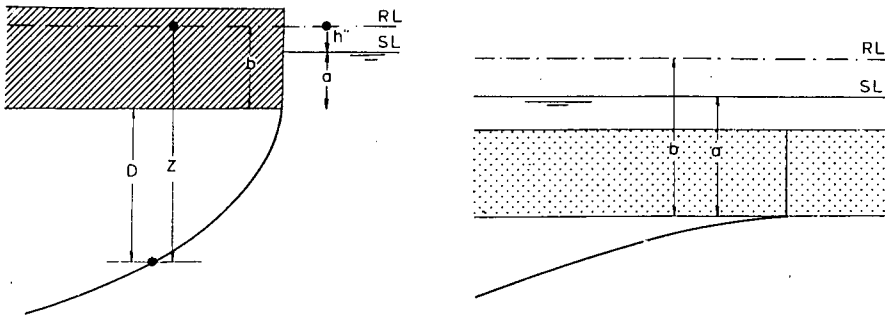

Fig. 70

surface W and the interface I are similar curves: the latter can be obtained from the former by multiplying the figure with a factor $-\gamma/(\gamma'' - \gamma)$ with respect to the sea level R . This factor is -40 when the density of the salt water is 1.025. In other words, for every metre the water surface rises above the sea level, the interface is 40 m below it. This law is valid for steady flow with salt water at rest. Enormous mistakes have been made by engineers who have drawn practical conclusions from it, applying it to nonsteady flow. Their idea was that the interface would suddenly rise by 40 m when the water surface is lowered by one meter, for instance due to pumping a well. Actually this rise does take place, but over a period of tens or hundreds of years. During this long period of nonsteady flow the above mentioned law is not valid.

Figure 70. - If the aquifer is confined or partly confined, a similar proportionality between D and φ exists:

$$D = \varphi/(\gamma'' - \gamma')$$

if the reference level is chosen at a distance b above the top of the aquifer, where

$$b = (\gamma''/\gamma)a$$

Under these conditions

$$\varphi'' = -\frac{\gamma''}{\gamma}(\gamma'' - \gamma) a; \quad h'' = -\frac{\gamma'' - \gamma}{\gamma} a$$

In the figure a , b and D denote absolute values, whereas Z and h'' are algebraic quantities, here both negative. SL indicates sea level; RL reference level.

- | In the expression
- | (1) $D = -Z - b$

| Z is defined by

| (2) $\varphi - \varphi'' = -(\gamma'' - \gamma)Z$

| while φ'' depends on h'' by

| (3) $\varphi'' = \gamma''h''$

| Finally the following geometric relation exists:

| (4) $a = b + h''$

| Eliminating Z , φ'' and h'' gives

| $\varphi = D(\gamma'' - \gamma) + (\gamma''a - \gamma b)$

| If the last term in brackets equals zero, D is proportional to φ according to

| $D = \frac{\varphi}{\gamma'' - \gamma}$. Putting this term equal to zero gives $b = \frac{\gamma''}{\gamma} a$.

It follows from the above that in a steady two-fluid system with salt water at rest, the reference level can always be chosen in such a way that φ is proportional to D .

In a phreatic aquifer:

$$D = \frac{\gamma''}{\gamma'' - \gamma} \frac{\varphi}{\gamma};$$

in a confined or partly confined aquifer:

$$D = \frac{\gamma}{\gamma'' - \gamma} \frac{\varphi}{\gamma}$$

This makes comparison possible with a steady one-fluid system in a phreatic aquifer with variable D , where the reference level coincides with the bottom of the aquifer. Then

$$D = \varphi/\gamma$$

The only difference is a factor $\gamma''/(\gamma'' - \gamma)$ in the case of a phreatic aquifer, or a factor $\gamma/(\gamma'' - \gamma)$ in the case of a confined or partly confined aquifer.

In Section 3.1 it was shown that the formulas for constant D could be changed into those for variable D by replacing $D\varphi$ with $\varphi^2/2\gamma$. This theorem can be extended to two-fluid systems. It then reads: the formulas for φ and q are identical when the following quantities are interchanged: (1) $D\varphi$ for one-fluid systems with constant D , (2) $\varphi^2/2\gamma$ for one-fluid systems with variable D , (3) $\frac{\gamma''\varphi^2}{2\gamma(\gamma'' - \gamma)}$ for two-fluid systems in phreatic aquifers, (4) $\frac{\varphi^2}{2(\gamma'' - \gamma)}$ for two-fluid systems in confined or partly confined aquifers.

This theorem is subject to the assumptions already made: steady flow, salt water at

rest in the two-fluid system, given n , reference level as indicated for each case separately. The flow nets formed by stream lines and equipotential lines remain unchanged when in each system the equipotential lines are drawn at equal increments of the respective interchangeable quantity. Examples will be given in the following sections.

The essential point of the proof is in the law of linear resistance, which for a one-fluid system with variable D reads (in the x direction)

$$q = -kD \frac{\partial \phi}{\partial x} = -\frac{k}{2\gamma} \frac{\partial \phi^2}{\partial x}$$

and for a two-fluid system in a phreatic aquifer

$$q = -kD \frac{\partial \phi}{\partial x} = -\frac{k}{2\gamma} \frac{\gamma''}{\gamma'' - \gamma} \frac{\partial \phi^2}{\partial x}$$

The second equation can be derived from the first by replacing

$$\frac{\phi^2}{2\gamma} \text{ with } \frac{\gamma'' \phi^2}{2\gamma(\gamma'' - \gamma)}$$

The principle of superposition is valid in the four cases alike, when the values of n and q (q_x and q_y) are added in each instance, those of ϕ in the one-fluid systems with constant D , and those of ϕ^2 in the three other instances. The proof of this thesis for two-fluid systems is similar to that of Chapter 3; the constant factor does not play a role in the proof. Once the values of ϕ are known from superposition, those of D , h , and Z can be obtained from the given relationships.

6.2.4 Parallel flow; salt water at rest

Figure 71. - The left part represents a cross-section of a long land strip, bordered by two parallel vertical boundaries, and containing a phreatic aquifer. The sea level at both sides is the same ($h'' = 0$). The aquifer receives a uniform recharge n .

Under these conditions a fresh-water body forms, as indicated in the figure, through which the fresh water received from recharge flows off to the sea at both sides. The salt water underneath is at rest. The formulas are:

$$\phi^2 = \frac{\gamma(\gamma'' - \gamma)}{\gamma''} \frac{n}{k} x(l - x)$$

$$q = n \left(\frac{l}{2} - x \right)$$

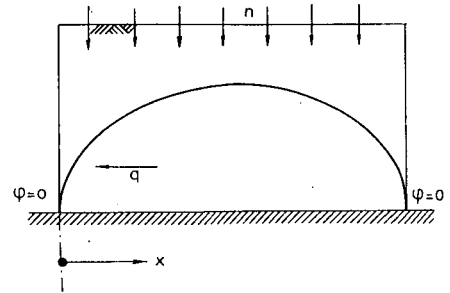
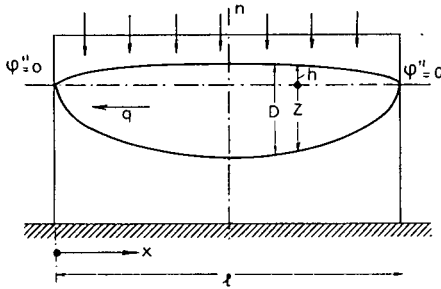

Fig. 71

$$h^2 = \frac{(\gamma'' - \gamma)}{\gamma\gamma''} \frac{n}{k} x(l-x)$$

$$Z^2 = \frac{\gamma}{\gamma''(\gamma'' - \gamma)} \frac{n}{k} x(l-x)$$

$$D^2 = \frac{\gamma''}{\gamma(\gamma'' - \gamma)} \frac{n}{k} x(l-x)$$

In the middle section, where h and $-Z$ attain their maximum values:

$$\varphi^2 = \frac{\gamma(\gamma'' - \gamma)}{\gamma''} \frac{nl^2}{4k}$$

$$h^2 = \frac{\gamma'' - \gamma}{\gamma\gamma''} \frac{nl^2}{4k}$$

$$Z^2 = \frac{\gamma}{\gamma''(\gamma'' - \gamma)} \frac{nl^2}{4k}$$

$$D^2 = \frac{\gamma''}{\gamma(\gamma'' - \gamma)} \frac{nl^2}{4k}$$

These formulas can be derived from those of Section 3.3 (see bottom figure). The formulas of that section, for System II, were

$$\varphi^2 = \frac{\gamma n}{k} x(l-x); \quad q = n \left(\frac{l}{2} - x \right).$$

Replacing φ^2 by $\frac{\gamma''}{\gamma'' - \gamma} \varphi^2$ gives:

$$\varphi^2 = \frac{\gamma(\gamma'' - \gamma)}{\gamma''} \frac{n}{k} x(l-x); \quad q = n \left(\frac{l}{2} - x \right).$$

From the expression for φ , those for h , $-Z$ and D can be derived with the relationships given in the same section.

The formulas may also be established directly from the differential equations. These are:

- The law of linear resistance in fresh water

$$q = kD \frac{d\varphi}{dx}$$

- The law of continuity in the fresh water

$$\frac{dq}{dx} = -n$$

- The law of discontinuity at the interface

$$\varphi - \varphi'' = -(\gamma'' - \gamma)Z, \text{ where } \varphi'' = 0$$

The following auxiliary conditions should be added:

$$h = \varphi/\gamma; \quad D = h - Z$$

These five equations define φ , q , Z , h and D for the boundary conditions

$$\begin{aligned} \text{for } x = 0 \quad \varphi &= 0 \\ \text{for } x = l \quad q &= 1/2 nl \end{aligned}$$

From a physical point of view the results may be analysed as follows. The fresh-water body forms a lens, floating freely on the underlying salt water. In the middle section $q = 0$ for reasons of symmetry. In this section the interface is horizontal, since both q and q'' (and therefore v and v'') are zero. From the middle section towards both left and right, $|q|$ increases as a consequence of the received recharge n . Since moreover the section D decreases, $|v|$ increases, which corresponds to an increasing slope of both the water surface and the interface. At the coast the section reduces to zero, and $|v|$ tends to infinity. The slopes of both the surface and the interface tend to infinity (see Section 6.2.2).

6.2.5 Extraction from canals

In this section some remarks will be made on the yield of an aquifer in steady-state conditions, exploited by canals or galleries. Similar considerations on the extractions from wells will be given in the next section. A sharp interface is assumed, which is too favourable an assumption, as will be shown in Section 6.4.

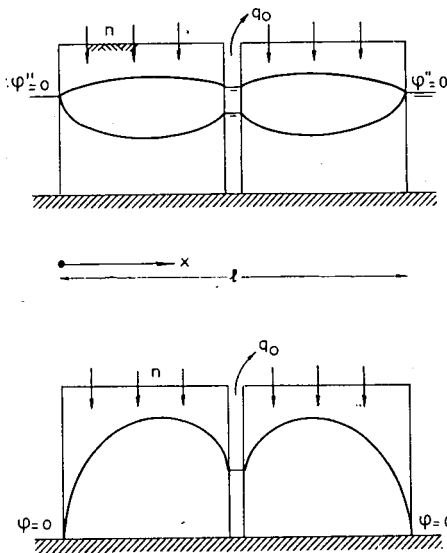

Fig. 72

Figure 72. – The situation to be examined first is the same as in the previous section, but with the addition of a canal in the middle section from which water is extracted at a uniform rate q_0 per unit length. The lower part shows the corresponding situation of a phreatic aquifer under one-fluid conditions. The formulas of the latter scheme have been established in Section 3.3. Upon application of the transformation described in Section 6.2.3. they become (for the left half of the figure, and $\varphi_1 = \varphi_2 = 0$).

$$\varphi^2 = \frac{\gamma(\gamma'' - \gamma)}{\gamma} \left[\frac{n}{k} x(l-x) - \frac{q_0}{k} x \right]$$

$$q = n \left(\frac{l}{2} - x \right) - \frac{1}{2} q_0$$

where h , $-Z$ and D are related to φ according to

$$h = \frac{\varphi}{\gamma} \quad -Z = \frac{\varphi}{\gamma'' - \gamma} \quad D = \frac{\gamma''}{\gamma(\gamma'' - \gamma)} \varphi$$

In the canal, for $x = l/2$:

$$\varphi^2 = \frac{\gamma(\gamma'' - \gamma)}{\gamma''} \left(\frac{nl^2}{4k} - \frac{q_0 l}{2k} \right)$$

Fig. 73

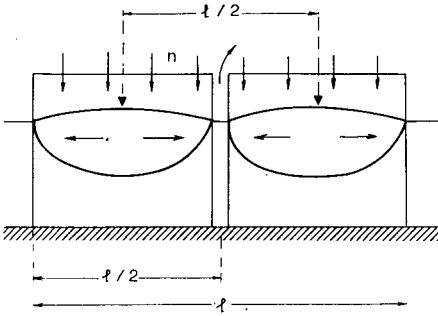

$$Z^2 = \frac{\gamma}{\gamma''(\gamma'' - \gamma)} \left(\frac{nl^2}{4k} - \frac{q_0 l}{2k} \right)$$

Figure 73. — The greater the extraction rate q_0 , the lower the level in the canal, and the higher the interface under the canal. The theoretical maximum for the extraction rate is reached when the interface rises to the water surface in the canal:

$$h = \varphi = 0; \quad -Z = 0; \quad q_0 = nl/2$$

The extraction is then one half of the recharge of the whole island.

The fresh-water lens is now cut into two halves. Each has a symmetrical form, since at both sides the following boundary conditions are valid:

$$\varphi = 0; \quad h = 0; \quad \varphi'' = 0; \quad h'' = 0$$

Each half may be compared with the lens described in the previous section. Since the breadth l is reduced to $l/2$, all dimensions reduce to one half, and the volume to one quarter, as can be seen from the formulas of Section 6.2.4.

As a conclusion, by exploiting a canal in the middle, no more than one half of the recharge can be extracted, which reduces the fresh water volume to one half of its original size.

This is the result as to the final steady state flow. For the exploitation the preceding non-steady period must also be considered. This period will not be studied in detail; the following remarks will merely be made. If the exploitation during the transition period is performed with the water level in the canal constantly at sea level, the extraction rate decreases gradually, and reaches the value q_0 when the steady state is approached. Under these conditions the extracted quantity is greater than if the exploitation had taken place at a rate q_0 from the beginning, in which case the water

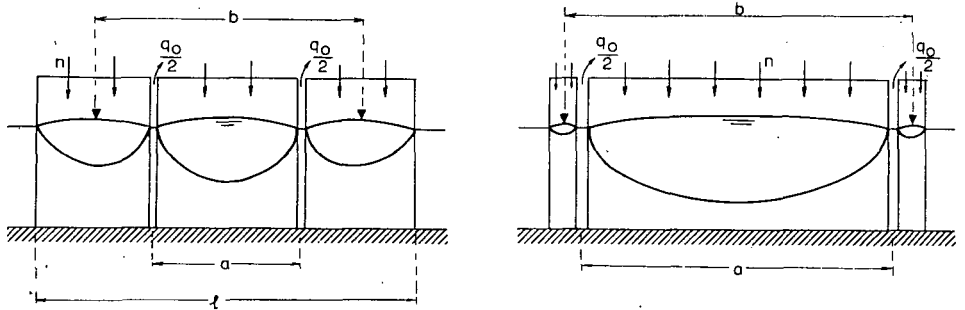

Fig. 74

level in the canal would have fallen gradually, the final steady state being the same. In both ways of exploitation the fresh-water volume under the island would reduce by one half of its initial value. In the first case a part of this water would be extracted, whereas in the second all of it would be lost to the sea. It is clear that in principle still more water can be extracted by lowering the water level in the canal below sea level during the first stage of exploitation. The modalities of such an exploitation, however, would have to be studied in detail.

Figure 74. – Instead of one canal in the middle of the island two parallel canals in symmetrical arrangement may be assumed, each extracting $q_0/2$ per unit length, so that the total yield is the same as in the last scheme. The theoretical maximum extraction rate in the final state is obtained when interface and water surface touch in the canals at sea level. The extraction rate from both canals together, defined in this way, can be established as a function of the distance between the canals. Since the canals receive the full recharge of the zone between the canals, and one half of the recharge of the outer zones, the extraction rate is:

$$q_0 = \frac{a + l}{2} n$$

If a increases from zero (one canal in the middle) to l (two canals near the coast), q_0 increases from $nl/2$ to nl .

As a conclusion, if the extraction takes place with one canal in the middle, the maximum yield is one half of the recharge of the island, and the final volume of the fresh-water lens is one half of the initial volume. If, instead, the extraction is performed by two canals near the coast lines, the yield is twice as great, equal to the full recharge of the island, and the final volume of the fresh-water lens is the same as in the beginning. The final state is then almost immediately reached. There is therefore a theoretical

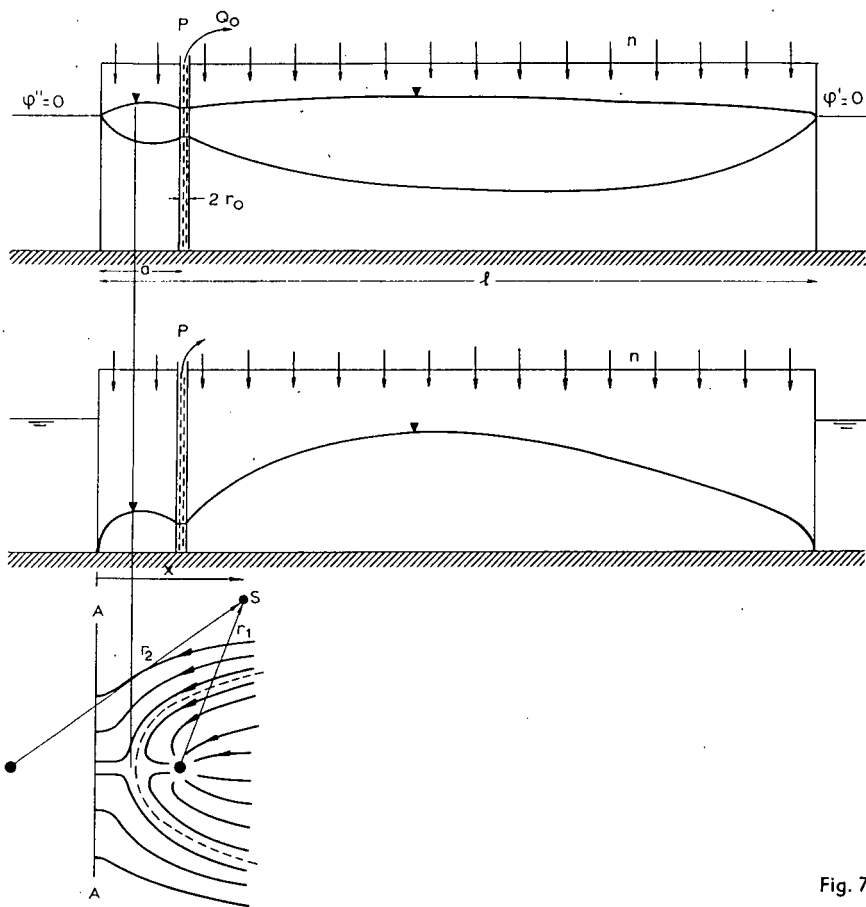

Fig. 75

advantage in placing the canals as near to the coast as possible, but this solution is seldom chosen for fear of extracting brackish water from the transition layer. This point will be discussed in Section 6.4.

6.2.6 A well near the coast

Figure 75. – The upper part shows a parallel flow model, representing a strip of land or an elongate island. The phreatic aquifer receives a uniform recharge n . The sea level at both sides is the same, equal to reference level ($\varphi'' = h'' = 0$). A single well P with extraction rate Q_0 , is sited at short distance a from the coast ($a \ll l/2$). The discussion will be limited to a narrow strip along the coast ($x \ll l/2$), where the fresh-water flow is approximately constant.

$$q = -nl/2.$$

The formulas for φ and q are those of Section 3.4 but with application of the transformation as described in Section 6.2.3.:

$$\begin{aligned}\varphi^2 &= \frac{(\gamma'' - \gamma)\gamma}{\gamma''} \left(\frac{nlx}{k} - \frac{Q_0}{\pi k} \ln \frac{r_2}{r_1} \right) = \frac{(\gamma'' - \gamma)\gamma}{\gamma''} A \\ h^2 &= \frac{(\gamma'' - \gamma)}{\gamma''\gamma} A; \quad Z^2 = \frac{\gamma}{\gamma''(\gamma'' - \gamma)} A; \quad D^2 = \frac{\gamma''}{\gamma(\gamma'' - \gamma)} A \\ q &= -\frac{2a}{r_1 r_2} e^{i(\theta_1 + \theta_2)} - \frac{nl}{2}\end{aligned}$$

In the well

$$\varphi_0^2 = \frac{(\gamma'' - \gamma)\gamma}{k\gamma''} \left(nla - \frac{Q_0}{\pi} \ln \frac{2a}{r_0} \right)$$

It is clear that for physical reasons φ^2 must be positive at all points of the aquifer, in particular in the well, where the water level is lowest and the interface highest. The theoretical maximum rate of extraction from the well is therefore given by

$$\varphi_0 = h_0 = Z_0 = 0$$

which, according to the given formula, corresponds to

$$Q_0 = \frac{\pi nla}{\ln(2a/r_0)}$$

The dotted line, separating the parts of the aquifer whose water flows towards the canal and the well, does not reach the canal. The two other situations examined in Section 2.4.4 do not apply here, since they require potentials in the well lower than in the sea.

In reality the extraction rate must be lower, firstly to allow for a safety margin, but principally because of the upconing of the transition layer, as will be explained in Section 6.4.2. It can be deduced from the given formula that the maximum value of Q_0 increases when a increases and r_0 remains the same (not shown here).

6.2.7 Partly confined aquifer

Figure 76 shows a cross-section of a parallel flow model with a partly confined aquifer. On the right-hand side the model is bounded by a impermeable wall, which may also be considered a symmetry axis, in which case the figure would represent only one half of the model. Between A and B the aquifer receives a uniform recharge n . The downward flow through the top layer causes a uniform loss of potential in vertical direction,

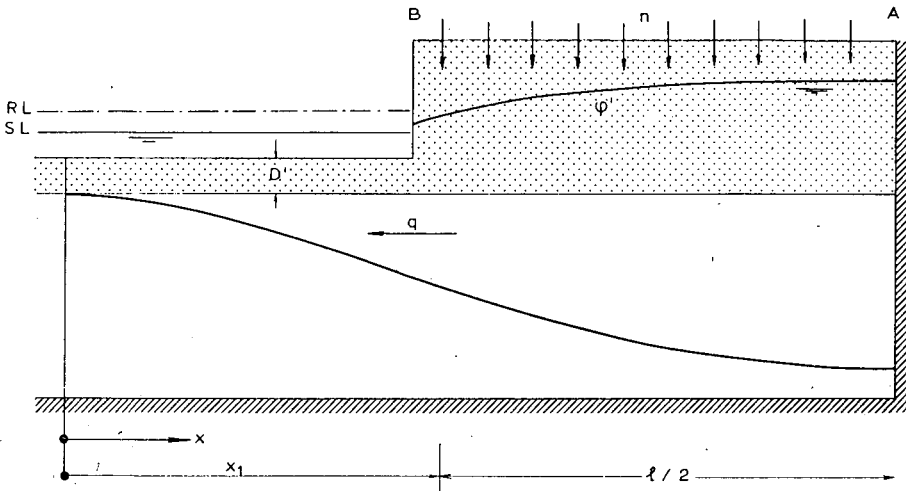

Fig. 76

so that the ϕ' line in that part of the model is parallel to the ϕ line. To the left of B the aquifer extends to infinity; it is covered by the sea.

The part AB may represent a dune series, and the part to the left of B a shallow sea. If beyond point C, where no flow occurs, the top layer were entirely eroded by the sea, this would have no effect on the flow system. The water received by the aquifer over the part AB flows off to the sea, but finds its upward movement hampered by the top layer. As shown in the figure, a 'tongue' forms, thus facilitating the upward flow through the top layer by increasing the area. At the extremity C the interface encounters the top layer at a small angle, not zero.

The situation as sketched might raise doubts as to the stability of the sea water above the fresh water contained in the top layer. This question will not be analysed here from a theoretical point of view. It suffices to mention that the existence of tongues, as drawn, has been proved both in a laboratory model and in nature. In the latter case borings have shown that the thickness of the fresh-water body does not tend to zero near the coast line, while water has been pumped from a well drilled in the sea some distance off the coast.

Figure 77. - The reference level has been chosen so that D is proportional to ϕ , which implies (see Section 6.2.3).

$$h'' = -\frac{\gamma'' - \gamma}{\gamma} a; \quad b = \frac{\gamma''}{\gamma} a$$

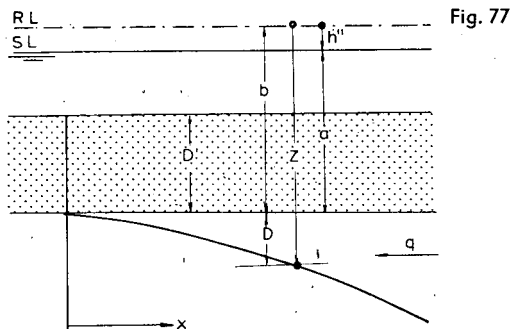

Fig. 77

$$Z = -D - b = -D - \frac{\gamma''}{\gamma} a$$

$$\varphi = (\gamma'' - \gamma) D; \quad \varphi'' = -\frac{\gamma''}{\gamma} (\gamma'' - \gamma) a$$

In these formulas Z and h'' are algebraic quantities (both negative), whereas a, b, D and D' are absolute values.

For the part CD (the 'tongue') the solution reads:

$$D = \frac{k'}{k} \frac{x^2}{6D'} + \sqrt{\frac{k'}{k}} x$$

$$\varphi = (\gamma'' - \gamma) D$$

$$q = k(\gamma'' - \gamma) D \sqrt{\frac{2}{3} \frac{k'}{k} \frac{D}{D'} + \frac{k'}{k}}$$

At the extremity C, the angle of encounter between the interface and the top layer is defined by dD/dx for $x = 0$, or $\sqrt{k'/k}$, a small angle, since k' is small compared with k .

The solution depends on the following equations:

- The law of linear resistance

$$(1) \quad q = kD \frac{d\varphi}{dx}$$

- The law of continuity

$$(2) \quad \frac{dq}{dx} = \frac{k'}{D'} (\varphi - \varphi')$$

where φ' is the fresh-water potential just below the top of the layer with low permeability.

- The law of discontinuity at the top of the layer with low-permeability.

$$\varphi' - \varphi'' = -(\gamma'' - \gamma)(-b + D')$$

or, after expressing φ'' and b in a ,

$$(3) \varphi' = -(\gamma'' - \gamma)D'$$

where a cancels out.

- The law of discontinuity at the interface

$$\varphi - \varphi'' = -(\gamma'' - \gamma)Z$$

which, as a result of the choice of the reference level, reduces to

$$(4) \varphi = (\gamma'' - \gamma)D$$

- Eliminating q , φ and φ' from (1), (2), (3) and (4)

$$\frac{d^2(D^2)}{dx^2} = AD + B$$

where $A = 2k'/kD'$ and $B = 2k'/k$

Multiplying both sides by $D \frac{dD}{dx}$ and integrating term after term

$$D \frac{dD}{dx} = \sqrt{\frac{A}{3} D^3 + \frac{B}{2} D^2 + c_1}$$

where c_1 is an integration constant. Multiplying by $k(\gamma'' - \gamma)$:

$$q = k(\gamma'' - \gamma) \sqrt{\frac{A}{3} D^3 + \frac{B}{2} D^2 + c_1}$$

The integration constant is found from the condition

$$\text{for } D = 0 \quad q = 0$$

which makes $c_1 = 0$ and

$$q = k(\gamma'' - \gamma) D \sqrt{\frac{A}{3} D + \frac{B}{2}}$$

$$\frac{dD}{dx} = \sqrt{\frac{A}{3} D + \frac{B}{2}}$$

Integrating the last equation by separating the variables.

$$D = \frac{A}{12} (x + c_2)^2 + \sqrt{\frac{B}{2}} (x + c_2)$$

The integration constant c_2 is determined by

for $x = 0$ $D = 0$
 which gives

$$c_2 = 0 \text{ or } c_2 = -\frac{12}{A} \sqrt{\frac{B}{2}}$$

Only the first value has a physical meaning, since the other makes dD/dx negative for $x = 0$.

The formulas of part AB read:

$$D^2 = \frac{nx}{k(\gamma'' - \gamma)} (2x_1 + l - x) + c$$

where c is an integration constant.

$$\varphi = (\gamma'' - \gamma)D$$

$$q = n \left(x_1 + \frac{l}{2} - x \right)$$

The basic equations are:

- The law of linear resistance

$$q = kD \frac{d\varphi}{dx}$$

- The law of continuity

$$q = n \left(x_1 + \frac{l}{2} - x \right)$$

- The law of discontinuity at the interface

$$\varphi = (\gamma'' - \gamma)D.$$

Eliminating φ and q from these three equations yields the formula for D .

The values of x_1 and c depend on both parts AB and BC. Since in section B, separating these parts, q is known to be $nl/2$, the formulas of part BC define the values of x , (x_1), and D , (D_1), in that section. The result cannot be given explicitly, since a third degree equation in D is involved. When D_1 and x_1 are known, substitution into the formula for D of part AB yields the value of c .

Fig. 78

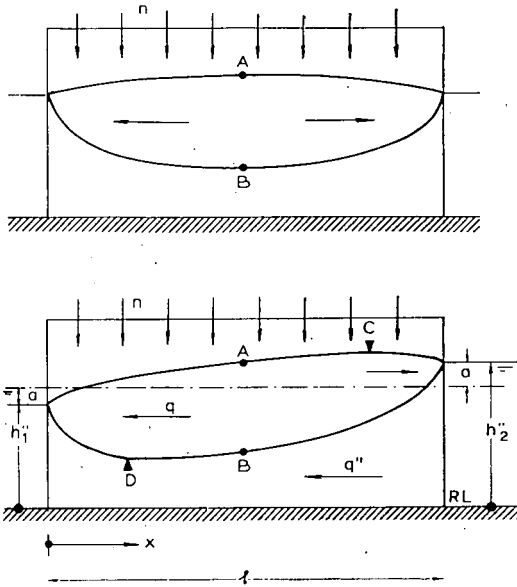

6.2.8 Flowing salt water

Steady-state systems with flowing salt water are rare in nature. They presuppose either two different sea levels or salt water extraction. Whereas different sea levels seldom occur, salt water flow may exist under a dune series bounded by fields that are drained below sea level. This case will be examined in the first example. In the second, salt water extraction will be studied with a view to increasing the long-term extraction of fresh water from the lens under an island.

The differential equations of steady flow with moving salt water are non-linear. Even the simplest schemes of parallel flow pose difficult mathematical problems. Indeed, no scheme was found that could serve as an example for exact solution. The analysis of both schemes therefore will be qualitative only. Since it is extremely hard to draw conclusions from differential equations, the reasoning is not fully exact, but contains some assumptions which will most probably be confirmed by further investigation. The proof, however, remains to be given. For the first example the differential equations will be given, but not solved.

Different sea levels

Figure 78. – The scheme indicated in the lower part can best be derived from a symmetrical system with salt water at rest, as represented in the upper part of the figure. The latter system corresponds to parallel flow in a phreatic aquifer, bounded at both sides by the sea at the same level and receiving a uniform recharge n . This system was

examined in Section 6.2.4. The lower scheme, also in steady flow conditions, differs from the previous one only in that the sea level on the right is raised by a small height a , and the level on the left lowered by as much. If a is relatively small, the lower part of the figure will resemble the upper part, and conclusions can be drawn with some probability from a comparison of the schemes.

For reasons of symmetry it is probable that the heights of the points A and B will be about the same as in the upper part of the figure, while the surface as well as the interface at these points will most probably be inclined towards the left. If these assumptions are correct, it follows that the highest point C of the surface will be at the right-hand side of the middle section, and the lowest point D of the interface at the left-hand side, as indicated in the figure.

In section C the fresh water separates into a flow to the left and a flow to the right. In the section itself $v = 0$, whereas $v'' \neq 0$, directed to the left. According to the law of discontinuity at the interface, written in terms of velocities, this difference between v and v'' corresponds to an interface, sloping to the left as indicated in the figure. In section D the interface is horizontal, which corresponds to $v = v''$, both directed towards the left.

The differential equations and the boundary conditions of this system will be established below, to show how the problem can be posed mathematically, but the solution will not be attempted. The differential equations are:

– The law of linear resistance in the fresh water

$$(1) \quad q = kD \frac{d\phi}{dx}$$

– The same in the salt water

$$(2) \quad q'' = kD'' \frac{d\phi''}{dx}$$

– The law of continuity in the fresh water

$$\frac{dq}{dx} = -n$$

or upon integration

$$(3) \quad q = q_0 - nx$$

where q_0 is the (unknown) value of q in the section where $x = 0$.

– The same in the salt water

$$(4) \quad q'' = q_0''$$

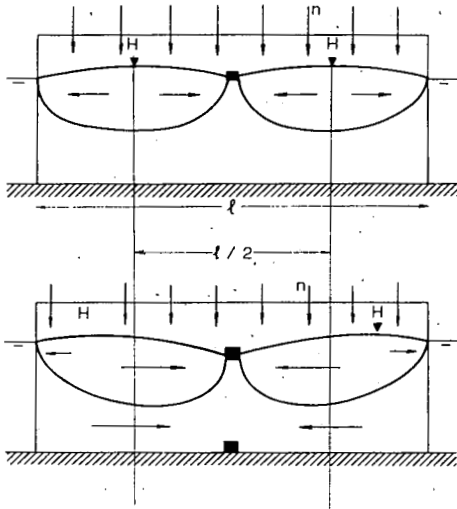

Fig. 79

where q_0'' is the unknown constant flow in the salt water

- The law of discontinuity at the interface

$$(5) \quad \varphi - \varphi'' = -(\gamma'' - \gamma)Z$$

To these equations must be added the following auxiliary relations

$$D'' = Z$$

$$D = h - Z = \frac{\varphi}{\gamma} - Z$$

The five differential equations relate the five variables φ , φ'' , q , q'' and Z to x , when the auxiliary relations are used to eliminate D and D'' .

The boundary conditions are

$$\text{For } x = 0 \quad \varphi = \gamma h_1$$

$$\text{For } x = 0 \quad \varphi'' = \gamma'' h_1$$

$$\text{For } x = l \quad \varphi = \gamma h_2$$

$$\text{For } x = l \quad \varphi'' = \gamma'' h_2$$

Extraction of salt water

Figure 79. - The upper part represents the scheme examined in Section 6.2.5, characterized by:

- Steady parallel flow in a phreatic aquifer, bounded at either side by salt water.

- At both sides the same salt water level, which corresponds to reference level ($\varphi = \varphi'' = 0$).

- Uniform recharge n .

- Extraction $q = nl/2$ from a gallery in the middle of the island.

This scheme corresponds to the theoretical maximum extraction of fresh water from the aquifer: surface and interface touch at sea level in the middle of the island. The aquifer is divided into two halves. The highest points H of the surface are $l/2$ apart. One half of the island's recharge is received between these two points, and drained to the gallery; the other half, received outside the points, is lost to the sea.

In principle, if the assumptions to be made are correct, the same drain can produce more fresh water if salt water is simultaneously extracted from the middle section. Such extraction must be done by means of wells, but to explain the principle a gallery is assumed. The lower part of the figure shows the steady flow system that results from a slight extraction of salt water. This system differs little from the first one, and can be compared with it. Fresh water is extracted at such a rate that surface and interface touch in the middle section, as they did in the first system.

The fresh-water lens at the right-hand side is in the same position as that between different sea levels, studied before. On the basis of the assumptions made there, it would follow that the tops H of the surface are farther apart than in the upper figure, which means that the fresh-water gallery extracts more than one half of the island's recharge.

It should be kept in mind that this reasoning is given to show the principle. For application, practical and economical factors must be considered. From a hydraulic point of view, the following remarks should be added:

- When surface and interface touch, the extreme theoretical limit is reached; in a design a safety margin should be introduced.

- A sharp interface has been assumed, whereas in reality the brackish water of the transition layer may play a predominant role.

- The effect of the salt water extraction depends on the transmissivity of the lower part of the aquifer. The impermeable bottom should not be too deep, or the lower part of the aquifer too permeable.

- The effect of a series of wells extracting salt water is less uniform, and therefore less favourable from an exploitation point of view, than the effect of a gallery.

Since some of these remarks are of great weight, it is clear that the method has been discussed for didactic reasons rather than with a view to practical application. The system might be studied in some cases in combination with the principle set out in Section 6.4.3.

6.3 NON-STEADY FLOW

6.3.1 Differential equations and boundary conditions

Figure 80. – The flow system is defined by the following differential equations:

– The law of linear resistance in the fresh-water layer

$$(1) \quad q_x = -kD \frac{\partial \phi}{\partial x}; \quad q_y = -kD \frac{\partial \phi}{\partial y}$$

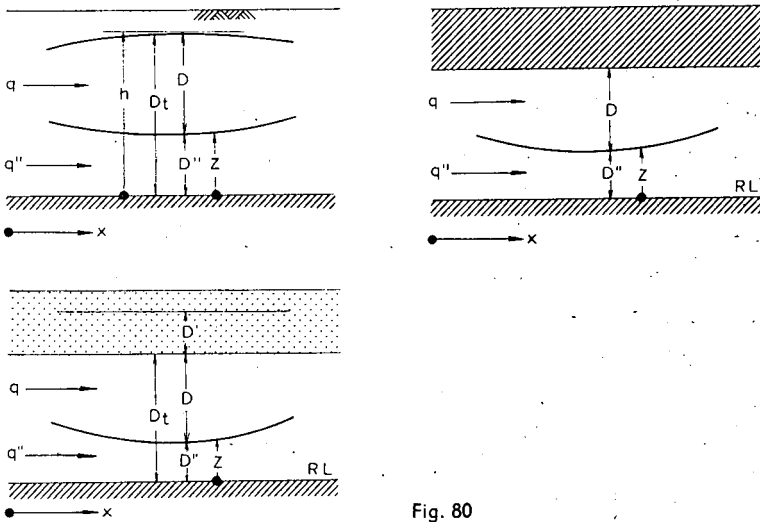

Fig. 80

– The law of linear resistance in the salt-water layer

$$(2) \quad q_x'' = -kD'' \frac{\partial \phi''}{\partial x}; \quad q_y'' = -kD'' \frac{\partial \phi''}{\partial y}$$

– The law of continuity in the fresh-water layer

$$(3) \quad \frac{\partial q_x}{\partial x} + \frac{\partial q_y}{\partial y} = N + m \frac{\partial Z}{\partial t}$$

where m is the effective porosity of the soil. In the case of
a. a phreatic aquifer

$$N = n - \frac{m}{\gamma} \frac{\partial \phi}{\partial t}$$

(In the chapters on one-fluid systems the quantity $\frac{m}{\gamma}$ has been written as μ)

b. a partly confined aquifer

$$N = \left(n - \frac{m'}{\gamma} \frac{\partial \phi'}{\partial t} \right) = \frac{k'}{D'} (\phi' - \phi)$$

where m' is the effective porosity of the top layer

c. a confined aquifer

$$N = 0$$

- The law of continuity is the salt-water layer

$$(4) \quad \frac{\partial q_x''}{\partial x} + \frac{\partial q_y''}{\partial y} = -m \frac{\partial Z}{\partial t}$$

- The law of discontinuity at the interface.

$$(5) \quad \phi - \phi'' = -(\gamma'' - \gamma)Z$$

These five differential equations relate ϕ , ϕ'' , q (q_x and q_y), q'' (q_x'' and q_y'') and Z to x , y and t , if the quantity N is defined as above and the sections of flow are determined by the following auxiliary relations. These will be written under the assumption that the reference level coincides with the bottom of the aquifer.

In a phreatic aquifer

$$D'' = Z$$

$$h = \phi/\gamma$$

$$D = h - D'' = \frac{\phi}{\gamma} - Z$$

In a confined or partly confined aquifer

$$D'' = Z$$

$$D = D_i - D'' = D_i - Z$$

In problems concerning phreatic aquifers, n will be given as a function of x , y and t , independent of ϕ . In problems concerning partly confined aquifers, depending on the problem, either ϕ' or n will be given as a function of x , y and t , independent of ϕ .

In addition, initial and boundary conditions are required to define individual flow systems. Both are doubled in number in comparison with a one-fluid system. As an initial condition may be given: the form of both the phreatic surface and the interface at the moment $t = 0$, or ϕ and ϕ'' as functions of x and y at that moment, or any equivalent pair of conditions. The boundary conditions are similar to those of one-

fluid problems, but their number must be doubled, while the potentials and rates of flow at the boundaries may vary with time. Examples will be given in the following sections.

6.3.2 Superposition

The principle of superposition can be applied without approximation to confined and partly confined aquifers, and only with approximation to phreatic aquifers.

In problems concerning confined or partly confined aquifers, any System III can be separated into two elementary systems, I and II, which have the same interface, but different values of $\Delta\gamma$ ($= \gamma'' - \gamma$). The superposition is valid for a short period dt during which the displacement of the interface is negligible, or for periodic variations of small amplitude, causing negligible displacement of the interface. The following quantities are added φ , φ'' , q , q'' and N (n and φ') and their derivatives with respect to x , y and t ; furthermore ΔZ and $\frac{\partial Z}{\partial t}$. Since the two systems have the same Z but

different $\frac{\partial Z}{\partial t}$, it is recommended, in order to avoid confusion, that $\left(\frac{\partial Z}{\partial t}\right)_I$ be written rather than $\frac{\partial Z_I}{\partial t}$, though both notations are theoretically correct:

The proof follows from

- The law of linear resistance in fresh and salt water, written for the x direction as an example

$$q_x = -kD \frac{\partial \varphi}{\partial x} \quad q_x'' = -kD'' \frac{\partial \varphi''}{\partial x}$$

Since the two systems have the same interface, the values of D and D'' are the same. Moreover, the definition of k has been given in such a way that k is the same in fresh and salt water. Thus the equations can be added by adding the values of φ and q , or of φ'' and q'' .

- The law of continuity in fresh and salt water (in the x direction as an example)

$$\frac{\partial q_x}{\partial x} + \frac{\partial q_y}{\partial y} = N + m \frac{\partial Z}{\partial t}$$

$$\frac{\partial q_x''}{\partial x} + \frac{\partial q_y''}{\partial y} = -m \frac{\partial Z}{\partial t}$$

These equations are linear in q_x , q_y , q_x'' , q_y'' , N and $\partial Z/\partial t$ so that they can be added by adding the respective values of these quantities.

- In the case of a confined aquifer

$$N = 0$$

- in the case of a partly confined aquifer

$$N = n - \frac{m'}{\gamma} \frac{\partial \varphi'}{\partial t} = \frac{k'}{D'} (\varphi' - \varphi)$$

This relation is linear in n , $\partial \varphi' / \partial t$, φ' and φ , which quantities may be added.

- The law of discontinuity at the interface

$$\varphi - \varphi'' = - \Delta \gamma Z$$

where $\Delta \gamma$ (positive) stands for $\gamma'' - \gamma$. Since the two systems have the same interface, Z is the same, and the values of φ , φ'' and $\Delta \gamma$ may be added.

The condition that $(\Delta \gamma)_I + (\Delta \gamma)_{II}$ equals the true difference in specific weight does not define each of the quantities $(\Delta \gamma)_I$ and $(\Delta \gamma)_{II}$ individually. A choice can be made. In each of the examples given below, one of the systems will be given the true difference in specific weight, and the other, or the others, homogeneous fluid ($\Delta \gamma = 0$). This choice does not yet determine Systems I and II: still other characteristics may be defined arbitrarily, e.g. one system steady, the other nonsteady.

In problems concerning phreatic aquifers the principle of superposition cannot be applied without approximation. Two systems with different φ have different $h (= \varphi/\gamma)$, and with the same Z they have different D . According to the method adopted, only one of the elementary systems is a two-fluid system. Only here do D and D'' have a physical meaning. The approximation is that $D + D''$, as determined from this system, is not exactly equal to the thicknesses of the aquifer, as assumed in the one-fluid systems.

In all problems (concerning confined and partly confined, as well as phreatic aquifers) superposition during a period Δt is only allowed if in each section the variation ΔD of D is small compared with D . In the case of periodic movement the amplitude of the variations of D , to be called ΔD as well, should be small compared with D . This condition needs verification, since D tends to zero near the coast. The mathematical condition is that $\Delta D/D$ remains small when D tends to zero.

Nonsteady two-fluid problems are usually difficult from a mathematical point of view. To avoid the accumulation in one system of complications resulting from difference in densities and nonsteady movement, it is advisable to choose the elementary systems so that the two-fluid system is steady, while the movement of the interface results from the one-fluid systems. The movement of the interface in homo-

geneous fluid systems must therefore be studied in detail.

Physically no interface exists in those systems, but mathematically Z plays a role in the superposition. It is therefore useful to imagine two layers of water of the same density, but of different colour, so as to maintain the notion of the interface.

The velocity in both water layers is the same. This follows from

$$v - v'' = k(\gamma'' - \gamma) \operatorname{tg} \alpha$$

where $\gamma'' - \gamma = 0$, and therefore $v - v'' = 0$. Thus q and q'' are proportional to the respective flow sections

$$\frac{q}{D} = \frac{q''}{D''} = \frac{q + q''}{D + D''}$$

where $D + D'' = D_1$.

The one-fluid system may be steady or nonsteady, but in both cases the interface (between the colours) is likely to displace, since even in steady flow there is no reason why the interface should coincide with a stream line. The displacement of the interface is determined by

$$(1) \quad \frac{\partial Z}{\partial t} = - \frac{D''}{D + D''} \frac{N}{m}$$

where $D + D'' = D_1$.

This follows from the law of continuity in fresh and salt water:

$$\frac{\partial q_x}{\partial x} + \frac{\partial q_y}{\partial y} = N + m \frac{\partial Z}{\partial t}$$

$$\frac{\partial q_x''}{\partial x} + \frac{\partial q_y''}{\partial y} = - m \frac{\partial Z}{\partial t}$$

Dividing these equations by each other gives the result mentioned since, according to the foregoing, the left-hand members are in the ratio D/D'' to each other.

In a phreatic aquifer N is the sum of two terms, depending on n and $\partial h/\partial t$, respectively.

$$(2) \quad N = n - m \frac{\partial h}{\partial t}$$

and

$$(3) \quad D = h - Z$$

On elimination of N from (1), (2) and (3) it follows that

$$\frac{\partial D}{\partial t} = \frac{D''}{D + D''} \frac{n}{m} + \frac{D}{D + D''} \frac{\partial h}{\partial t}$$

$$\frac{\partial Z}{\partial t} = \frac{\partial D''}{\partial t} = -\frac{D''}{D + D''} \frac{n}{m} + \frac{D''}{D + D''} \frac{\partial h}{\partial t}$$

Thus the variation of Z , D or D'' can also be written as the sum of two terms depending on n and $\partial h/\partial t$ respectively.

For $n = 0$ these formulas become

$$\frac{\partial D}{\partial t} = \frac{D}{D + D''} \frac{\partial h}{\partial t}$$

$$\frac{\partial Z}{\partial t} = \frac{\partial D''}{\partial t} = \frac{D''}{D + D''} \frac{\partial h}{\partial t}$$

When applying the superposition to a time interval Δt , and writing Δh and ΔD for the increments of h and D during that interval, the first equation indicates that

$$\frac{\Delta D}{D} = \frac{\Delta h}{D + D''}$$

The same formula applies when Δh and ΔD represent the amplitudes of a periodic movement.

This result should be interpreted as follows: if the variations of D result from variations of h only ($n = 0$), and these are small in relation to the total thickness of the aquifer, (right-hand member small) then $\Delta D/D$ remains small when D vanishes near the coast, which was a condition for application of the principle of superposition. An example is given in Section 6.3.4.

From the above the following law may be deduced, which applies to any system where superposition, as described, is applicable. If in a two-fluid model one or more of the hydraulic quantities determining the flow system, are suddenly changed, the aquifer reacts as if it were filled with homogeneous water, as long as the displacements of the interface are small. The same is true for periodic variations of these quantities, if they create small displacements of the interface. The hydraulic quantities determining the flow system are: the potentials and flow rates at the boundaries, the recharge and, in the case of a partly confined aquifer, the ϕ' values.

Examples (provided the displacements of the interface are small) are:

- A pumping test on a fresh-water well gives as a result the transmissivity of the whole aquifer: kD_t .
- Tidal variations or seasonal variations of a river level propagate uniformly through fresh and salt water.
- Seasonal variations in rainfall or percolation from drainage affect fresh and salt water alike.
- The same is true for a sudden change in ϕ' in a partly confined aquifer, due to drainage or irrigation.

For systems affected by a sudden change in the hydraulic conditions, the proof is based on the consideration that immediately after the change the system can be considered the sum of two elementary flow patterns:

- System I, representing the conditions before the change. In this system $\gamma'' - \gamma$ has the real value.
- System II, characterized by the change in the hydraulic conditions, combined with $\gamma'' - \gamma = 0$, representing homogeneous water.

In the case of periodic variations System I is characterized by the average values of the hydraulic quantities and the true difference in densities, whereas System II contains the variations around zero value, in combination with $\gamma'' - \gamma = 0$ (homogeneous water).

The formulation of the proof in general terms may lack precision; examples will be given in the following sections.

6.3.3 Partly confined aquifer

In this and the following sections some examples will be given of nonsteady flow systems. In the present section the solution will be given by means of a numerical method. In Chapter 7 more examples of nonsteady systems will be shown, also solved by numerical methods, but then applied to systems depending on two horizontal coordinates x and y , whereas the present scheme depends on x only. As will be seen, there is some difference in method. In the present section the differential equations are used as they are; in Chapter 7 after some quantities have been eliminated.

Figure 81. - The model is defined by parallel flow in a partly confined aquifer. The boundary conditions are constant:

Outside the sections A and B a constant sea level. Reference level coincides with sea level: $\phi'' = h'' = 0$.

Inside the sections A and B, ϕ' is given numerically as an arbitrary function of x , independent of time.

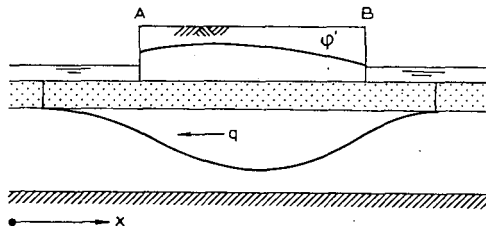

Fig. 81

For an arbitrary moment t , Z is given numerically as an arbitrary function of x . The problem is to determine the flow system during the subsequent elementary interval Δt , and in particular $\partial Z/\partial t$ as a function of x , so that the values of Z an elementary time interval Δt later can be established, and the calculation repeated.

Since even the calculation of one single interval Δt takes much time, the examination of a sequence of intervals may easily exceed the capacities of an engineer working by hand, and computers would have to be used. Still, the work by hand can be taken into consideration: firstly, for didactic reasons, to acquire some familiarity with the method on a simple example; secondly, in cases where the interface moves very slowly, and the first interval, or the first few, already cover the period in which the planned works are written off by depreciation; finally, one interval may be calculated to check a computer program.

In calculations of this kind the length of the aquifer is divided by section lines into a sufficient number of elements of equal length Δx . The quantities φ , φ' , φ'' , N , Z and $\partial Z/\partial t$ are measured on the section lines, while q and q'' are measured in the fields between these lines. The thicknesses of the aquifers D and D'' , although directly related to Z , are measured in the fields as an average of the values on the adjacent lines. $\partial\varphi/\partial x$ is determined as $\Delta\varphi/\Delta x$ where $\Delta\varphi$ is the difference in φ between two successive section lines. The value of $\partial\varphi/\partial x$ obtained applies to the field between the lines, where also q is measured. $\partial q/\partial x$ is determined as $\frac{\Delta q}{\Delta x}$, where Δq is the difference in q between two successive fields.

Some difficulty arises at the extremities of the fresh-water body under the sea, where the condition $q = 0$ requires that the extremity is in the middle between two section lines. Since this point is moving, it may be anywhere. The condition $q = 0$ is therefore applied to the whole field in which the point is located. The error is small when Δx is small.

The values of Z at the beginning of the interval are used for the whole time interval, which introduces a recurring error, always in the same sense. This imperfection must be accepted if the simplicity of the method is to be safeguarded.

For each period Δt the nonsteady system, III, is split up into two elementary systems, I and II.

System I is defined by

- The true values of $\Delta\gamma$
- Outside the sections A and B, $\varphi'' = 0$
- The values of Z , corresponding to the form of the interface at the beginning of the interval.
- Steady flow (salt water at rest $\varphi'' = 0$).

This system can be calculated, as will be shown below. As a result, φ'_I is found on each section line. These values are different from the given φ'_{III} values. System II therefore must be characterized by

$$\varphi'_{II} = \varphi'_{III} - \varphi'_I$$

System II is then defined by

- Homogeneous fluid.
- Outside the sections A and B, $\varphi'' = 0$
- $\varphi'_{II} = \varphi'_{III} - \varphi'_I$
- $Z_{II} = Z_I$, but only as a separation between layers of different colour.

System II is steady as is System I, but the interface (between the colours) moves, since it does not coincide with a flow line. The calculation of System II gives as a result the values of $\partial Z/\partial t$ in each section line, and thus the new value of Z to be taken as a basis for the calculation of the next time interval.

The operations follow the steps indicated below.

System I:

(1) φ on the section lines is determined by the law of discontinuity at the interface

$$\varphi - \varphi'' = -\Delta\gamma Z$$

where Z is given, $\varphi'' = 0$, and $\Delta\gamma$ has the true value.

(2) q in the fields is determined by the law of linear resistance.

$$q = kD \frac{\partial\varphi}{\partial x}$$

where $\partial\varphi/\partial x$ is derived from φ by differentiation on finite increments, while D is geometrically related to Z .

(3) N on the section lines is determined by the law of continuity

$$\frac{\partial q}{\partial x} = -N$$

where $\partial q/\partial x$ is derived from q by differentiation on finite increments.

(4) φ'_i on the section lines is determined by

$$N = \frac{k'}{D'} (\varphi' - \varphi)$$

System II corresponds to that of Section 4.2.4: flow in homogeneous fluid filling a partly confined aquifer, where between the sections A and B, φ' ($=\varphi'_{III} - \varphi'_i$) is given as an arbitrary function of x , and outside these limits is zero to infinity. Thus any physical quantity can be determined, in particular N (its values on the section lines). Since for each section line Z and therefore D'' is known, $\partial Z/\partial t$ follows from

$$\frac{\partial Z}{\partial t} = - \frac{D''}{D_i} \frac{N}{m}$$

Thus Z at the beginning of the next time interval can be determined, and the cycle repeated.

6.3.4 Propagation of the tide

Figure 82. - A phreatic aquifer with approximately constant D is bounded by two parallel sides. It receives a constant recharge n , while the sea level at both sides varies according to

$$\varphi'' = \varphi''_0 \sin \omega t$$

where $T = 2\pi/\omega$ is the period of the tide. The amplitude of the tide is small compared with the thickness of the aquifer.

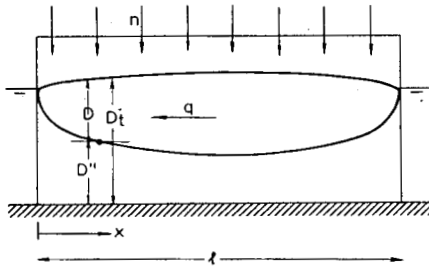

Fig. 82

The solution can be found by superposing two systems, I and II.

System I is defined by

- The true value of $\Delta\gamma$
- Recharge n
- $\varphi'' = 0$ at both sides.

This is the steady-flow system examined in Section 6.2.4. The formulas from that section can be used. They define in particular the shape of the interface and the phreatic surface, or in mathematical terms, Z and h as functions of x .

System II is defined by

- $\Delta\gamma = 0$; homogeneous fluid
- No recharge: $n = 0$
- Tidal movement: $\varphi'' = \varphi_0'' \sin \omega t$

This is the nonsteady flow system in homogeneous fluid, studied in Section 5.3.2.

The formulas can be found by simple summation of those of the two elementary systems. They will not be given here. Only some characteristics of the system will be analysed.

The water surface as well as the interface describe small oscillations around their average position, which is that of System I. These oscillations propagate from the coastlines inwards. Thus the fresh-water body transforms continually, somewhat like a figure on a flag floating in the wind.

The condition that the variations of D in any section are small as compared with the value of D must be verified. These variations occur only in the homogeneous flow system, II, which is independent of n , since n only occurs in System I. It was shown in Section 6.3.2 that in a homogeneous fluid system with $n = 0$ the variations of D are related to those of h by

$$\frac{\Delta D}{D} = \frac{\Delta h}{D + D''}$$

In any section the amplitude Δh is smaller than, or of the order of, the tidal amplitude, which is assumed small compared with the thickness of the aquifer $D + D''$. Therefore the condition is satisfied that the amplitude ΔD is small in comparison with D . It should be noted that the sections near the coast are singular points in the mathematical solution of both Systems I and III. A further analysis of the extremity of the fresh-water body should be made, as indicated in Section 3.2, giving special attention to the horizontal flow of System II, which tends to displace the last, steep part of the interface.

6.3.5 Periodic variations in recharge rate

Figure 83. - The model is the same as in the previous section: a phreatic aquifer with approximately constant thickness, bounded by two parallel planes. The sea level at both sides is now assumed constant ($\varphi'' = 0$), whereas the recharge varies according to

$$n = n_1 + n_0 \cos \omega t$$

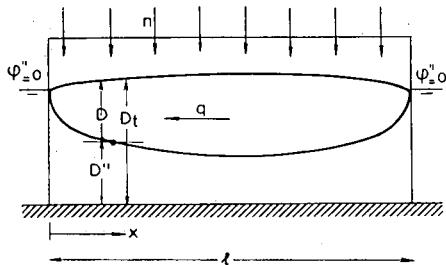

Fig. 83

If the period $T = 2\pi/\omega$ is one year, the formula corresponds to seasonal variations in recharge rate.

The solution can be found by superposition of three elementary systems, following the same reasoning as in Section 5.3.3.

System I:

- The true value of $\Delta\gamma$
- Average recharge n_1
- Constant sea levels, $\varphi'' = 0$

This is the steady-state system of Section 6.2.4. The formulas are

$$\varphi^2 = \frac{\gamma(\gamma'' - \gamma)}{\gamma''k} n, x(l - x)$$

$$q = n_1 \left(\frac{l}{2} - x \right)$$

$$h = \frac{\varphi}{\gamma} \quad - \quad Z = \frac{\varphi}{\gamma'' - \gamma} \quad D = h - Z = \frac{\gamma''}{\gamma'' - \gamma} \frac{\varphi}{\gamma}$$

System II:

- $\Delta\gamma = 0$ Homogeneous fluid.
- Recharge $n = n_0 \cos \omega t$
- Sea levels varying according to

$$\varphi = \frac{n_0 \gamma}{m\omega} \sin \omega t$$

The formulas of this system are:

$$\varphi = \frac{n_0 \gamma}{m\omega} \sin \omega t \text{ or } h = \frac{n_0}{m\omega} \sin \omega t$$

$$q = 0$$

System III:

- $\Delta\gamma = 0$, homogeneous fluid
- No recharge $n = 0$
- Sea levels varying according to

$$\varphi = -\frac{n_0\gamma}{m\omega} \sin \omega t$$

The formulas are

$$\varphi = -\frac{n_0\gamma}{m\omega} \sum p e^{-\alpha u} \sin(\omega t - \alpha u)$$

$$h = \frac{\varphi}{\gamma}$$

$$q = -\frac{n_0}{\alpha\sqrt{2}} \sum s e^{-\alpha u} \sin\left(\omega t + \frac{2\pi}{8} - \alpha u\right)$$

where $\alpha = \sqrt{m\omega/2\gamma k D}$ and in the successive terms:

$p = +1$	$s = -1$	$u = x$
+1	+1	$l - x$
-1	+1	$l + x$
-1	-1	$2l - x$
+1	-1	$2l + x$
+1	+1	$3l - x$
-1	+1	$3l + x$
		etc.

The formulas of the whole system can be written by summing φ , h and q of the elementary systems, I, II and III.

It should be checked if in each section the variations of D are small compared with D . These variations are limited to Systems II and III, since System I is steady. In System III, $n = 0$, therefore

$$\frac{\Delta D}{D} = \frac{\Delta h}{D + D''}$$

ΔD and Δh being the amplitudes of the variations of D and h , where Δh is the total effect of a number of damped oscillations, not in phase with one another. Since Δh will not be greater than the amplitude of the sea level variations in System III, that is

$\frac{n_0}{m\omega}$, it suffices that this quantity be small compared with D , which was a premise of the calculation.

In System II, where $n \neq 0$, the variations of D can be found from the formulas of Section 6.3.2., but a shorter reasoning is possible. In this system no flow occurs, thus the interface is at rest. The surface moves up and down according to

$$h = - \frac{n_0}{m\omega} \sin \omega t$$

Thus the variations of D are the same as those of h , whose amplitude is $n_0/m\omega$. This quantity cannot always be small in comparison with D , since D reduces to zero at the ends of the fresh-water body. Although this fact condemns the calculation in principle, the formulas obtained may be acceptable as an approximation of the reality, considering that:

- Due to the steep slopes of interface and water surface near the coast, small values of D occur only over a limited length of the aquifer. Since D^2 is proportional to $x(l-x)$, it can be seen that over 9/10 of its length the fresh-water body has a thickness of more than 43% of the maximum or more than 56% of the average value.
- The variations of D are alternately positive and negative.
- Calculations of ground water, especially for orientation, are generally rough.

Since the extremities of the aquifer do not entirely satisfy the assumptions underlying the calculation, it is recommended that in any practical problem these parts be studied in detail. Assuming that in a particular case superposition is feasible with a fair approximation, interesting conclusions can be drawn as to the periodic accumulation of fresh water underground. Since both the surface and the interface move, the volume of the lens changes. The fresh-water body acts as a storage reservoir, whose characteristics can be analysed on the basis of the established formulas.

Figure 84. - Five quantities play a role, indicated schematically in Figure 84.

- N . The variation in recharge rate over the length l of the model, per unit breadth in the other direction

$$N = ln_0 \cos \omega t$$

- E . The variation in the flow rate of exchange between the aquifer and the sea at both sides. This flow occurs only in System III, which is a homogeneous fluid system. It is uniformly distributed over the height of the aquifer. Since the fresh-water body ends in a point, only salt water is exchanged, whereas the outflow of fresh water to the sea is constant, according to System I. E is determined by the formula of q in System III for $x = 0$:

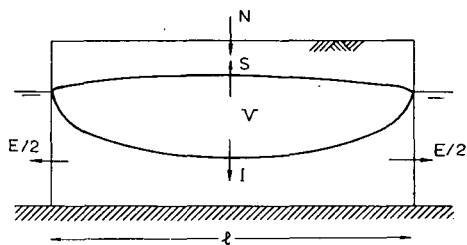

Fig. 84

$$E = -\frac{n_0\sqrt{2}}{\alpha} \sum s e^{-\alpha u} \sin\left(\omega t + \frac{2\pi}{8} - \alpha u\right)$$

where in the respective terms:

$s = -1$	$u = 0$
$+1$	l
$+1$	l
-1	$2l$
-1	$2l$
$+1$	$3l$
$+1$	$3l$

etc.

– I . The variation in the volume of fresh water contained in the lens, due to the displacements of the interface.

– S . The same for the displacements of the surface.

– V . The variation in the fresh water volume contained in the lens.

The five quantities N , E , I , S and V have the same dimension. They are sine functions of time with the same yearly period, but different phase and amplitude. They can be added and subtracted (either analytically or graphically as vectors). The result is always a sine function with the same period, but the amplitude is not simply the sum or the difference of the amplitudes of the terms. With these remarks in mind, the simple notation in sums and differences may be used.

– It follows from the incompressibility of the salt water that

$$I = E$$

which means equality in phase and amplitude. This formula defines I , since E is known.

– Since the water in the aquifer is incompressible:

$$N = S + E$$

which determines S , since N and E are known. Since $E = I$, also

$$N = S + I$$

The right-hand side clearly equals V :

$$N = S + I = V$$

This formula, written as $N = V$ expresses that the variations in recharge are fully stored in the fresh-water lens. Written $S + I = V$, where S and I are known, it indicates which parts S and I of the storage are due to the displacements of the surface and the interface respectively.

Since all five quantities N , E , I , S and V have the same dimension, they can be made dimensionless when dividing them by $n_0 l$, writing N' , E' , I' , S' and V' . Thus

$$I' = -\frac{\sqrt{2}}{\alpha l} \sum s e^{-\alpha u} \sin\left(\omega t + \frac{2\pi}{8} - \alpha u\right)$$

$$S' = N' - I' = \cos \omega t + \frac{\sqrt{2}}{\alpha l} \sum s e^{-\alpha u} \sin\left(\omega t + \frac{2\pi}{8} - \alpha u\right)$$

These formulas show that the relative importance of I' and S' depends only on the parameter

$$\theta = \alpha l = l \sqrt{m\omega/2\gamma k D}$$

the values of u in the series being multiples of l .

This relationship can be analysed mathematically (not shown here). On physical grounds it is clear that for great values of θ , S' is predominant, whereas for small values of θ , I' comes to the fore.

This can easily be seen by attributing great values of θ to great values of l and average values of m and kD . In an elongate model the waves of System III die out in the coastal zone, while the major part of the model is under the influence of System II, where the interface does not move, and S' stands for the whole accumulation. Low values of θ can be attributed to average values of l and m , and high values to kD . The phreatic surface then scarcely rises above sea level and does not accomplish important movements. Thus I' predominates.

6.3.6 Extraction of fresh water from a well or a gallery

In this section the problem of extracting fresh water from a well in a two-fluid system will be examined. The analysis will be qualitative only. It will be given first for a partly penetrating well in homogeneous soil and then for a fully penetrating well in aniso-

tropic soil (without resistance in vertical direction). Although the line of thought is the same in the two cases, the choice of the elementary systems is different. Therefore the results are difficult to compare. The analysis in the two hypothesis is most instructive and may be considered as a preparation for a more thorough examination of the problem of the partially penetrating well in two-dimensional flow schemes, which is outside the framework of this publication. It also forms an introduction to the study of the influence of the transition layer on water extraction from wells. The analysis is given for a well, but applies also to a gallery. The assumption of anisotropic soil without resistance in vertical direction would correspond fairly well to a gallery in broken limestone crossing a vertical fissure.

The extraction from a well in a large aquifer is a local and minor phenomenon in a much greater two-fluid system. Its influence extends in principle to the boundaries of the aquifer and can be split up, more or less artificially, into a local, rapid upconing of salt water under the well, and a wide-spread slow deformation of the whole fresh-water body. In order to study the first effect separately, the area around the well will be given artificial, steady boundary conditions, thus neglecting the second effect.

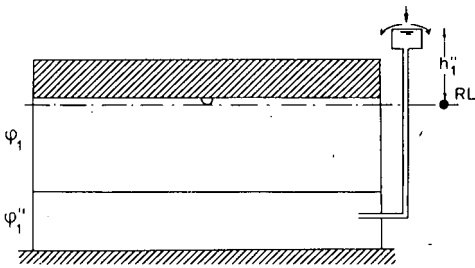

Fig. 85

Figure 85. - A circular boundary is assumed with a radius, two to three times the thickness of the aquifer, so as to imply nearly horizontal flow at the boundary. All around the circle φ and φ'' are kept artificially constant, which in a laboratory model can be done with a series of devices as shown schematically for the salt water in the figure. Water of the appropriate specific weight is supplied in abundance, so that the top overflows, which fixes the value of h'' , and therefore that of $\varphi_1'' = \gamma'' h_1''$. If the same is done for the fresh water, also φ_1 is fixed, and consequently the interface, since Z is determined by

$$\varphi_1 - \varphi_1'' = (\gamma'' - \gamma) Z$$

Since the diameter of the boundary is small compared with the horizontal dimensions of the aquifer, the recharge within the boundary may be neglected, which corresponds to the assumption of an impermeable top layer.

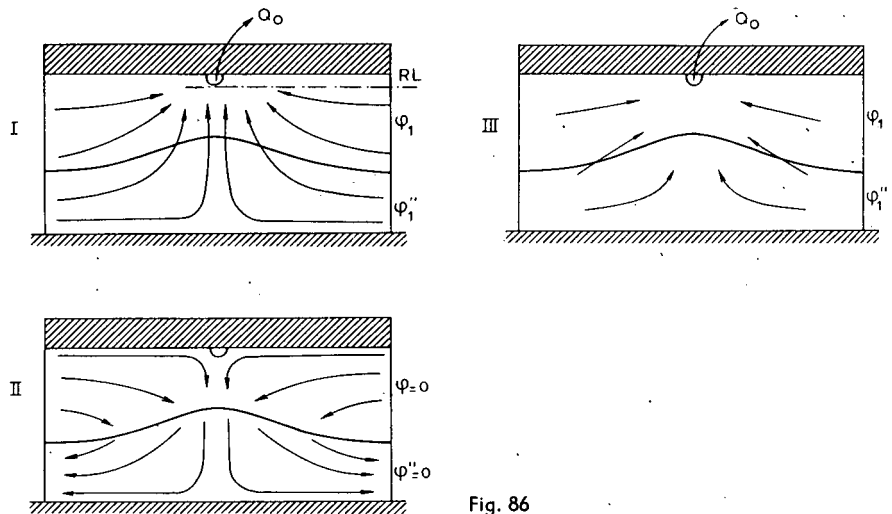

Fig. 86

The effect of water extraction will now be examined successively for a partly penetrating well in homogeneous soil and a fully penetrating well in anisotropic soil (without resistance in vertical direction).

Partially penetrating well

Figure 86. – The screen is assumed to be one half of a sphere at the top of the aquifer. The reference level passes through the lowest point of the screen. If the extraction rate is limited, a steady state will eventually be reached, where the top of the cone remains at a certain distance under the screen. In a marginal case it will just reach the screen. When the law

$$\varphi - \varphi'' = - (\gamma'' - \gamma)Z$$

is applied for the lowest point of the screen, where $Z = 0$, it is found that

$$\varphi_0 = \varphi_1''$$

where φ_0 is the potential in the well in the final state. Thus the condition that the top of the cone stabilizes under the screen is

$$\varphi_1'' < \varphi_0 < \varphi_1$$

which indirectly defines the marginal extraction rate.

At any moment of the nonsteady period, the flow system (III), is the sum of two

elementary systems, I and II, commonly characterized by the form of the interface at that moment, and further by:

System I:

- Homogeneous water ($\Delta\gamma = 0$)
- In the well $Q = Q_0$ (and $Q'' = 0$)
- At the boundary $\varphi = \varphi'' = 0$

System II:

- The true value of $\Delta\gamma$
- In the well $Q = 0$, ($Q'' = 0$)
- At the boundary $\varphi = \varphi_1$, and $\varphi'' = \varphi_1''$

This subdivision can be made for any moment of the nonsteady period as well as for the final state. System I is the same at any moment, although the form of the interface between the coloured layers changes. It is a steady-flow system in homogeneous water. Its streamlines point upwards and tend to displace the interface (between colours) in an upward direction, thus creating the cone. System II is characterized by nonsteady flow without extraction. The cone subsides by its weight.

Thus at any stage of the nonsteady period the interface is under the combined influence of System I raising it and System II lowering it, and these influences result in a rising up of the cone. In the final steady state these systems counterbalance each other, so as to keep the interface in place.

In the final state a certain instability may be expected, as can be seen from the following reasoning. If, as has been assumed, a final state is reached where the potential in the well is higher than φ_1'' no salt water can enter into the well. If now the diameter of the well, already assumed small, is reduced considerably further, the extraction rate remaining constant, the flow pattern in the aquifer will scarcely change and the potential on the half sphere corresponding to the former screen will remain about the same. But important potential losses are created between the place of the former screen and the new one, so that the potential in the well will be much lower and even considerably below φ_1'' . Thus salt water could, in principle, enter the well, which, however, will not occur because of the high potential at the place of the former screen. The question arises whether a second final state is possible. This problem is left for study on two-dimensional models.

Fully penetrating well

Figure 87. - The same problem can be posed for a fully penetrating well in anisotropic soil. The system (III) is again split up into two elementary systems, I and II, but characterized other than in the above analysis.

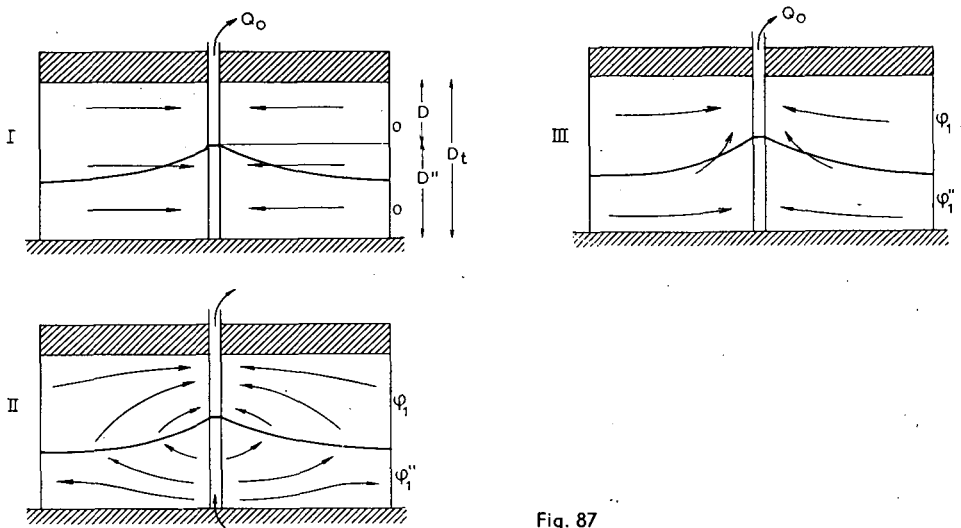

Fig. 87

System I:

- $\Delta\gamma = 0$ Homogeneous fluid.
- Extraction Q_0 from the well. Since the fluid is homogeneous, a part $(D/D_t) Q_0$ is extracted from the upper layer, and a part $(D''/D_t) Q_0$ from the lower layer.
- At the boundary $\phi = \phi'' = 0$

System II:

- The true difference in specific weight $\Delta\gamma$
- Extraction of fresh water at a rate $(D''/D_t) Q_0$ from the upper layer, and injection of salt water at the same quantity into the lower layer. The total extraction is zero. (The injection into the lower layer counterbalances the extraction of System I, while the extraction from the top layer brings the fresh-water supply up to Q_0).
- At the boundary $\phi = \phi_1$; $\phi'' = \phi_1''$.

System I is steady. Since the fluid is homogeneous, the streamlines are horizontal. The flow displaces the interface (between the colours) towards the well, which means that it lowers the cone.

System II is nonsteady. The water injected into the lower part of the well does not reach the boundary for the full amount. A part is stored in the rising of the interface. In the same way, the water extracted from the upper part of the well is not fully supplied through the boundary. A part of it is delivered from the rise of the interface. During the nonsteady period System I remains the same, but since the interface (between the colours) rises, the flow causes an increasing downward movement of the interface. System II changes with time. The quantities injected and extracted increase

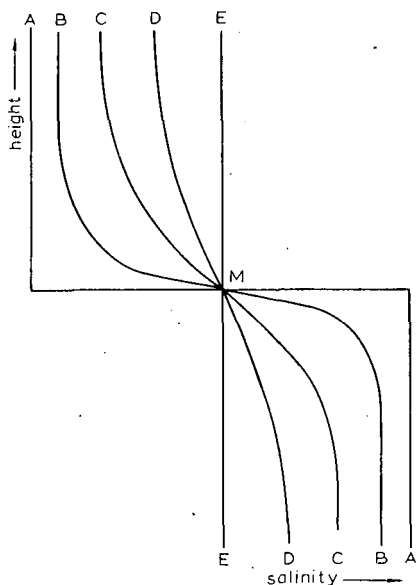

Fig. 88

with increasing D'' . Thus the effect of cone-building becomes stronger. Finally equilibrium is reached, where the combined influences of Systems I and II keep the interface in a steady position.

When the flow systems of the partially and the fully penetrating well are compared, a fundamental difference appears. Whereas in the case of a partially penetrating well System I raises the cone and System II lowers it, the reverse applies to the fully penetrating well. The difference is due to the different choice of the elementary systems, which is, however, in either case the most logical. The analysis of the partially penetrating well systems could be repeated on the basis of the other scheme by assuming a second screen at the bottom of the aquifer, but the study made in this way would be more artificial and less instructive.

6.4 TRANSITION LAYER

6.4.1 Fundamentals

Between fresh and salt water a transition layer develops for two reasons: (1) diffusion, which is the movement of salt molecules through the water and (2) displacement of water perpendicular to the interface or perpendicular to the transition zone, which is limited to nonsteady flow. Both factors will be examined in detail.

Figure 88. - (1) Diffusion can be studied on a groundwater model, filled with fresh and

salt water at rest and separated by a horizontal, sharp interface. The concentration of salt molecules in the salt water is higher than in the fresh water, where it is zero. As a consequence the molecules move upwards. The concentration in the salt water decreases; that in the fresh water increases. If the salt diagram is first AA, it becomes successively BB, CC, DD and after an infinitely long time EE. The latter line corresponds to total diffusion, where both layers have the same salinity. The laws governing this phenomenon will not be treated here in detail. Only the following remarks will be made:

- The phenomenon is slow; the formation of a transition layer may take tens or hundreds of years.
- The diffusion rate depends on the pore space; not on the permeability.
- The curve is symmetrical with respect to point M.

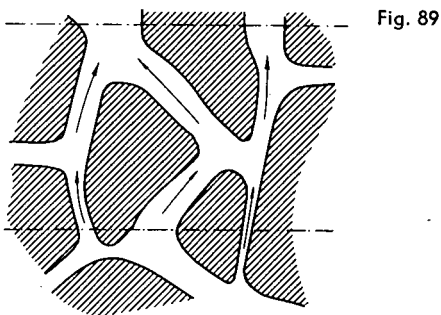

Figure 89. - (2) The second factor can be studied on the same model: two fluids at rest, separated by a sharp horizontal interface. If an upward flow sets in, the interface moves upwards, but does not remain a horizontal plane. The particles in the middle of large pores move more quickly than those in the middle of small pores; those in the middle of any pore move more rapidly than those near the sides, where the velocity reduces to zero; flow through vertical pores results in a faster rise than does flow through inclined openings. The same particle rises alternatively fast and slowly: By chance it may rise as a whole more quickly or more slowly than others.

Throughout the period of flow, differences in salinity tend to develop between the particles flowing alongside each other in the same pore: salt water particles moving faster than fresh water particles, salt water flow through vertical pores meeting fresh water yielded by inclined pores, etc. Appreciable differences in salinity, however, cannot persist on distances as small as the widths of the pores. On this scale, diffusion is effective and creates a zone of brackish water, increasing in thickness as the flow continues.

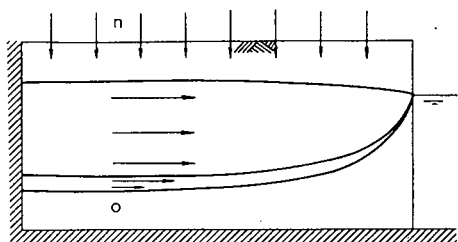

Fig. 90

Figure 90. – These two formative causes are counteracted by leaching, which phenomenon can be studied in its simplest form on the model of Figure 90. A parallel steady flow is assumed, created by uniform infiltration. The fresh groundwater flows towards the sea; the salt water is at rest. The intermediate layer not only constitutes a transition in salinity, but also in velocity. The flow rate varies gradually between the velocity of the fresh water and zero (salt water at rest). Thus the transition layer moves in all its parts, and each particle reaches the sea after a shorter or longer period.

In natural conditions equilibrium is eventually reached between formation and leaching, resulting in a certain thickness of the transition layer. In regions near the sea with off flow over a short distance in a permeable aquifer, the transition layer will be thin, and the fresh water of good quality. In regions farther from the coast, where the fresh water moves slowly over great distances, the transition layer may be considerably thicker, or may even reach the top of the aquifer, making the water unsuitable for consumption or irrigation.

If the transition layer is thin, there is an advantage in conserving this favourable situation by preventing the undue creation of brackish water. Thus constant extraction from a well or a gallery is, in principle, better than irregular or periodic pumping at the same average rate, because the vertical movements of the transition layer are limited. It is difficult, however, to give a quantitative appraisal of this effect.

6.4.2 *Extraction of fresh water from a well or a gallery*

As will be shown in this section the transition layer has a paramount and unfavourable influence on the exploitation of groundwater. Two examples will be given: one of a well or gallery near the centre of an island, that is without horizontal flow in the fresh water before the well is put into operation; the other of a gallery nearer to the coast, where an initial lateral flow exists. In both cases the transition layer is assumed thin compared with the thickness of the fresh-water layer, so that comparison is possible with the corresponding sharp interface systems.

For the analysis, which will be qualitative only, the transition layer may conveniently be replaced by a series of some five or more layers, each of constant specific weight, forming a transition in steps between fresh and salt water.

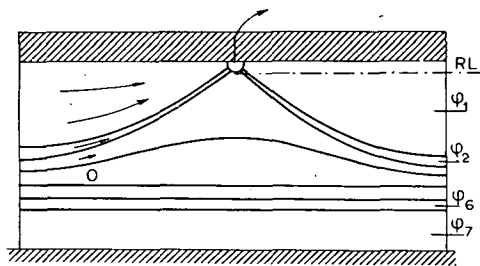

Fig. 91

Extraction in the centre of the island

Figure 91. – The model is almost the same as in Section 6.3.6. The artificial boundary conditions are reintroduced, as well as the devices regulating the potentials and the salinities of the water of the different layers. Five intermediate layers are assumed. The potentials at the boundary are φ_1 for the fresh water, φ_2 to φ_6 for the brackish water of the intermediate layers, and φ_7 for the salt water (the symbol φ'' being no longer used). At first all layers are at rest; the interfaces are horizontal. From a certain moment onwards a constant quantity Q_0 is extracted from the well.

When Q_0 is small, a final state (shown in Figure 91) will be reached, resembling that of Section 6.3.6, where no salt water reaches the screen since the potential φ_0 in the well is intermediate between φ_1 and φ_7 . Assuming that φ_0 is between φ_3 and φ_4 , then, in the final state fresh water will be extracted as well as water from the upper two intermediate layers, whereas the water in the three lowest layers, and the salt water, will be at rest. The lower layers are horizontal, since the interface between two fluids with different γ , both at rest, is horizontal. It should be noted that in the very beginning they rose under the influence of the streamlines of System I and then subsided. Such behaviour, derived from deductive reasoning, should be verified on a laboratory model, preferably with oil as a fluid, so as to exclude diffusion, which in a scale model is not reduced in the proper way.

The layers delivering into the well are separated by inclined interfaces. According to the same law, the velocity decreases in steps in a downward direction each time an interface is passed.

The same uncertainty exists as to the stability of the final state, when for a constant extraction rate the diameter of the well is reduced. This question may be studied on two dimensional flow models, not to be discussed here. The water from the upper layers of the transition zone certainly reaches the well. The other layers eventually might follow one after the other, thus allowing the salt water to reach the well. The final state would then be stable.

When it is admitted that the steady flow corresponds to the situation in the figure, the

result can be studied on its technical merits by considering a series of steady-state systems in the same model, differing only in extraction rate. This rate is small in the first system and greater in each of the following, until in the last system it reaches such a value that the salt water cone stays just under the screen. It is clear that even in the first model some brackish water is extracted; in each following system this quantity is greater because more intermediate layers give their water. In the last system the whole transition layer delivers into the well. Thus extraction of brackish water is unavoidable. This result contrasts with the behaviour of a two-fluid system with a sharp interface, where in all systems, even the last, the extracted water would be completely fresh.

It should be noted that the salinity of ocean water is of the order of 18,000 p.p.m. Cl'. Thus inmixing of only 2% into fresh water results in a salinity of 360 p.p.m., which exceeds the limit for drinking water, and is appreciable even for irrigation purposes. The given reasoning explains the unexpected salt troubles encountered so often in groundwater exploitation in coastal regions, where the influence of the transition layer had been overlooked.

It can also be seen from the above that the salt troubles increase with the thickness of the transition layer, expressed as a fraction of the thickness of the fresh water layer. Aquifers with thick transition layers may be unsuitable for extraction.

Drain near the coast

Figure 92 represents a steady-state parallel flow system in a phreatic aquifer, receiving a uniform recharge n . The model is bounded to the left by an impermeable wall and to the right by the sea. By diffusion a transition layer forms.

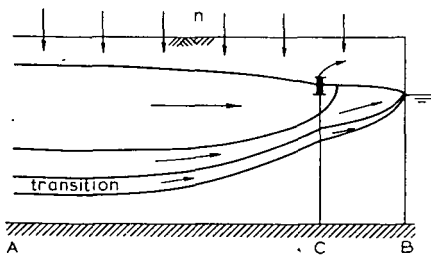

Fig. 92

If water is extracted at a low rate from a gallery at C, this water is supplied by the upper part of the fresh water body, whereas the lower part delivers into the sea, as indicated in the figure. This time the extracted water will be perfectly fresh. The extraction rate may be raised until only the brackish water flows to the sea and all the fresh water is collected in the gallery.

Although, in principle, fully fresh water is extracted, the solution should be considered with reserve for the following reasons:

- The nearer the gallery is to the sea, the thicker is the transition layer as compared with the thickness of the fresh water layer, since brackish water forms along the entire distance between A and B.
- A series of wells, replacing the gallery, would not have the same effect, since the division between the water extracted, and that lost to the sea would not take place in a vertical plane only, but also in a horizontal plane (water passing between two wells). If the wells are not too narrowly spaced, the flow in a cylinder around each well is radial, which brings the problem back to that of a well sited in the centre of an island, where extraction of brackish water is unavoidable.
- In limestone, local vertical fissures crossing the galleries would upset the effect in the same way as wells.

6.4.3 Double pumping

In Section 6.2.8. the theoretical possibility has been examined of extracting fresh and salt water simultaneously, with a view to increasing the fresh water production. An analogous technique will be described in this section, where fresh and brackish water are extracted simultaneously to avoid mixing. The method is based on the consideration that the extraction of brackish water is often unavoidable and the remedy is to extract it separately, and then to dispose of it.

Figure 93 represents a partially penetrating well, for instance an unlined borehole in finely fissured limestone, extracting fresh water as well as some brackish water from the transition layer. If the energy losses in the well are neglected, the potential at all points of the well face is the same. This potential depends on the extraction rate, regardless of whether the orifice of the pump is located in A or in B, or the same total quantity is extracted by two pumps in A and B, operating simultaneously. In these cases the flow pattern in the aquifer is the same, since it depends on the value of φ at the face of the well only. Whatever might be the flow pattern around the well, the brackish water will enter into its lower part and the fresh water into its upper part, as a consequence of the difference in density between the fluids. Since the flow is laminar, the two fluids do not mix. Thus a Section C exists, separating the fresh and brackish water entering into the well.

When the extraction rates of Pumps A and B are Q_A and Q_B respectively, a series of tests can be imagined where

$$Q_A + Q_B = Q_0$$

is the same, but Q_B is respectively 0%, 10%, 20%...100% of Q_0 . In all cases Section C will be the same, but Section P, where the incoming water divides into an upward

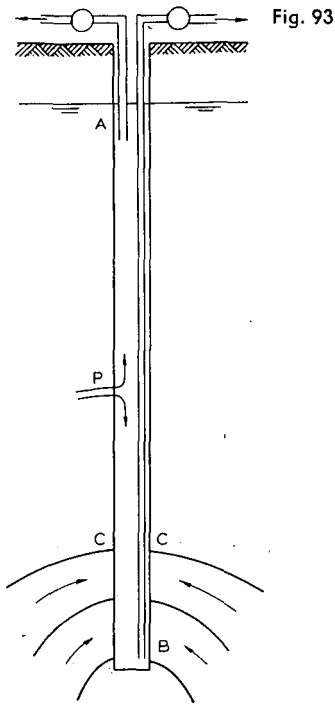

Fig. 93

and a downward flow inside the well, will be different. It is possible to choose Q_B so that Section P coincides with Section C, in which case Pump A extracts purely fresh water and Pump B all the brackish water. When Q_B is slightly further decreased in favour of Q_A , the salinity of Pump A can be raised to the maximum allowable concentration. The water of this pump is used, whereas that of Pump B is disposed of. The application of the method depends on several factors: economic, practical, hydraulic, etc, which have to be examined separately in each case. The physical base of the method has proved to be sound, as tests in sand, and even in fissured limestone formations have shown. The principle of a measuring technique developed during these tests will be described below. A separate section will be devoted to it, since its application is not restricted to the techniques of double pumping alone.

6.4.4 Testing saline boreholes

Figure 94. – In this section a measuring technique will be described to establish how the water enters during the pumping into an uncased well, or a screen of certain length. The result gives the distribution of the quantities and the salinities over the height of the well. The example given will be that of an uncased hole in limestone, receiving

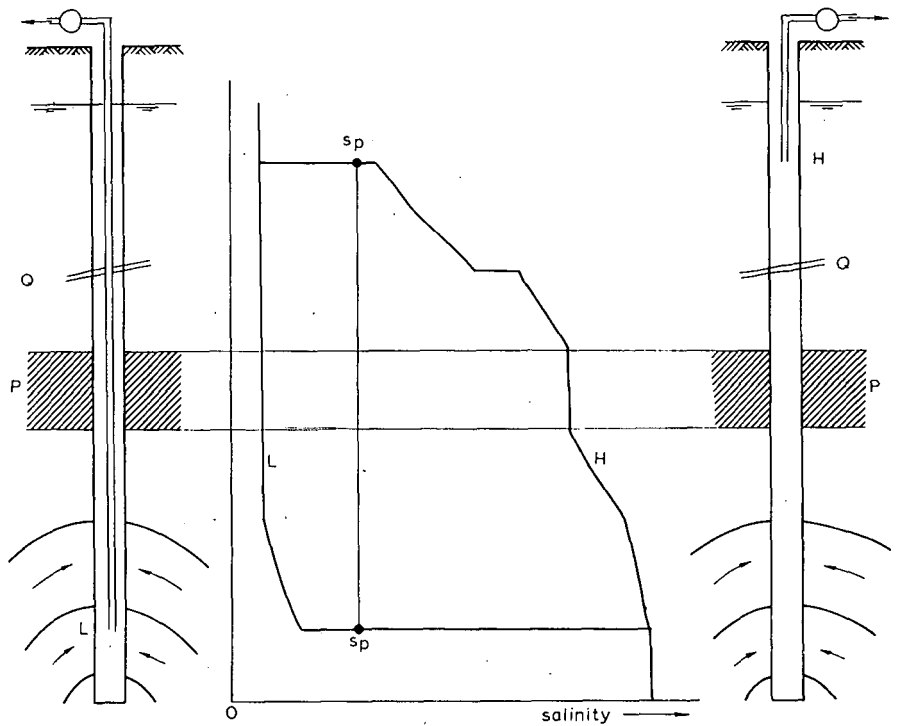

Fig. 94

fresh water in its upper part and brackish water in its lower. To make the example more general some complicating factors will be added: an impermeable layer P, and a big fissure Q, yielding abundant fresh water.

In two successive tests water is extracted at the same rate: in the first, the orifice of the pump is in the highest position H, in the second in the lowest position L. If the potential losses in the hole are neglected, φ is uniform over the entire face of the well. In both tests φ , and therefore the flow pattern around the well, is the same. Thus, the distribution over the height of the well of the quantities and the salinities of the entering water is the same too.

In both tests the salinities of the water flowing inside the well are measured during pumping as a function of the height, either by taking a series of samples to be examined in the laboratory, or by measuring the conductivity with an electrode sunk into the well. The instruments will not be described here.

The logs are different in the two tests.

- With the orifice in the low position the flow in the hole is downward, except in the

small part below the orifice, where it is upward. The downward flow is fresh in the upper part of the well, but the salinity increases gradually in the lower part, due to inflow of brackish water. The upward flow under the orifice is brackish. The two flows mix in the pump; the salinity S_p of the mixture is that of the extracted water.

- With the orifice in the high position the flow in the well is upward, except in the small part above the orifice, where it is downward. The upward flow is saline at the bottom of the hole. The salinity diminishes gradually, at first slowly by inflow of less saline water; then more rapidly due to inflow of fresh water. The impermeable layer P is characterized by unchanging salinity (in both diagrams); the fissure Q corresponds to a sudden decrease of the salt content. In the pump the saline upward flow mixes with the weak downward flow of fresh water, which results in the same salinity S_p of the water delivered by the pump.

From the two logs the distribution over the height of the well of the quantities and salinities of the inflowing water can be computed. The calculation is elementary and will not be discussed here.

As a first check on the method the measurement can be repeated: the same logs must be found again. A correct repetition indicates that the turbulence of the flow in the borehole is strong enough to mix the water in the well with the water entering through the sides and that there are no turbulent circuits of so great a vertical extension as to upset the stratification of the rising or sinking watercolumn.

As a second check more tests can be made with two pumps, working simultaneously at the same total rate, but the lower pump delivering different fractions, 10%, 20%... of the total. From the results already obtained, the logs of the new tests can be calculated beforehand and the results compared with the measurements.

The same method can be used for examining the quality of the water encountered during drilling of an uncased hole. In normal practice a suction pipe or a submersible pump is lowered to the bottom of the hole, and the lower part of the hole sealed off mechanically before the sample is taken. But as shown above, the orifice may be placed as high as possible and a sample may be taken during pumping from the bottom of the hole without sealing. The upward flow in the well guarantees that the sample is representative of the water entering the hole at the bottom. If only the conductivity is wanted, an electrode can be sunk in the hole. The method would fail when the lower part of the hole is in impermeable rock, the water being stagnant. The classical method would then fail as well.

7. NUMERICAL METHODS

If the boundaries of an aquifer have an arbitrary form, or the recharge is not uniformly distributed over the surface, the problem is generally too complicated to be solved by formal integration. In these cases numerical methods can be applied, either working 'by hand' or using computers. In the latter case one should be familiar with the principles of the method and should call in the aid of specialists in computer methods for determining the detailed program. Mechanization does not exclude calculation by hand. Simultaneous manual solutions may be required as a check on the computer program e.g. to study one out of a series of analogous problems, or a simple scheme of the same kind as the more complicated problem given to the computer.

Apart from any particular result, however, numerical methods are instructive: they are more suitable for the formation of ideas than is formal integration. It is therefore recommended that in studying groundwater hydraulics some of the easier calculations be made by hand.

Section 7.1 will deal with so-called iteration methods. The term iteration denotes the repetition of an elementary operation until, by successive approximations, a result of sufficient precision is obtained. In principle the process is infinite, but the operations can be terminated when it becomes obvious that continuation would not change the result appreciably. The method is comparable to that of summing an infinite series. In both cases the proof has to be given that the method converges and that the result is unique.

Section 7.2 will provide some examples of more straightforward numerical methods, which in general are simpler than the iteration methods. They may be used alone or in combination with iteration.

Both kinds of numerical methods can be applied to one-dimensional flow (parallel or radial) as well as to two-dimensional, depending on two horizontal coordinates x and y . In Section 6.3.3 an example was given of application to one-dimensional flow. In this chapter only the more difficult two-dimensional problem will be examined. The application of the same methods to one-dimensional flow is left to the reader.

7.1 ITERATION METHODS

7.1.1 Elementary example

Figure 95. – In this section an elementary example will be given, showing the method in its simplest, though not its most efficient form. In the following sections more complicated problems will be treated and some perfections of the method will be shown. An aquifer without recharge will be considered, bounded by two river branches R and a lake L. The form of the boundaries, as well as the potentials in the river branches are arbitrary; the potential along the lake has a constant value. The flow is steady.

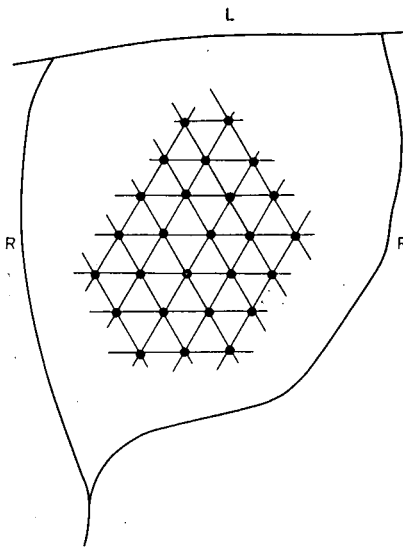

Fig. 95

When the calculation is made by hand, the plan of the boundaries is drawn on a large scale in lead pencil on heavy paper. A net of triangles, as indicated in Figure 95, is then drawn on transparent paper. Its scale is chosen so that some twenty or thirty points fall within the boundaries when the transparent paper is placed on the plan of the aquifer. By shifting the transparent paper, the net is brought into such a position

that a fair number of its points coincide with the boundaries. For the rest the boundaries are slightly deformed, so as to follow the straight lines of the net. The net in this position, limited by the deformed boundaries, is then drawn in ink on the heavy paper. The potential values along the boundaries are inscribed in ink as well.

An estimate is then made of the value of the potential at each point of the aquifer. These values are a mere guess, reflecting the engineer's first idea in this matter; they are of course all more or less wrong and are to be corrected in the course of the operations. The accuracy of the first estimate is not without importance: the nearer it is to reality, the shorter will be the work of correction.

As will be shown in Section 7.1.3 the value of the potential at any point, if it were correct, would be the average of the six surrounding values. Since it is not correct, there is a difference. This law of the average is the simplest form of a more complicated relationship in more general conditions. In the present problem it stands for the differential equation

$$\frac{\partial^2 \varphi}{\partial x^2} + \frac{\partial^2 \varphi}{\partial y^2} = 0$$

but applies to finite differences.

When applying the most simple method, one corrects the values of the potential at the nodes in a given succession, rubbing out the estimated value and replacing it with the average of the six surrounding values. After this has been done for all nodes, the definite result is not yet reached, since the new values of the potential have been calculated on the base of surrounding values, not all of which had been corrected at that moment. The operation must therefore be repeated several times. In principle an infinite number of repetitions is required, but the work can be terminated when it becomes obvious that continuation would not change the result appreciably.

The proof of convergence will be postponed to Section 7.1.4., where the problem is explained in a slightly different way, providing a better base for considerations on this point. In that same section it will be explained at what moment the work can be terminated.

It can readily be seen that the solution is defined and unique. There are as many unknown values of φ as there are points in the field (as opposed to the points at the boundaries). The basic formula, which is a linear relationship between some of the unknowns, can be written for each field point as a centre. Thus there are as many linear equations as there are unknowns. The solution is therefore defined as well as unique.

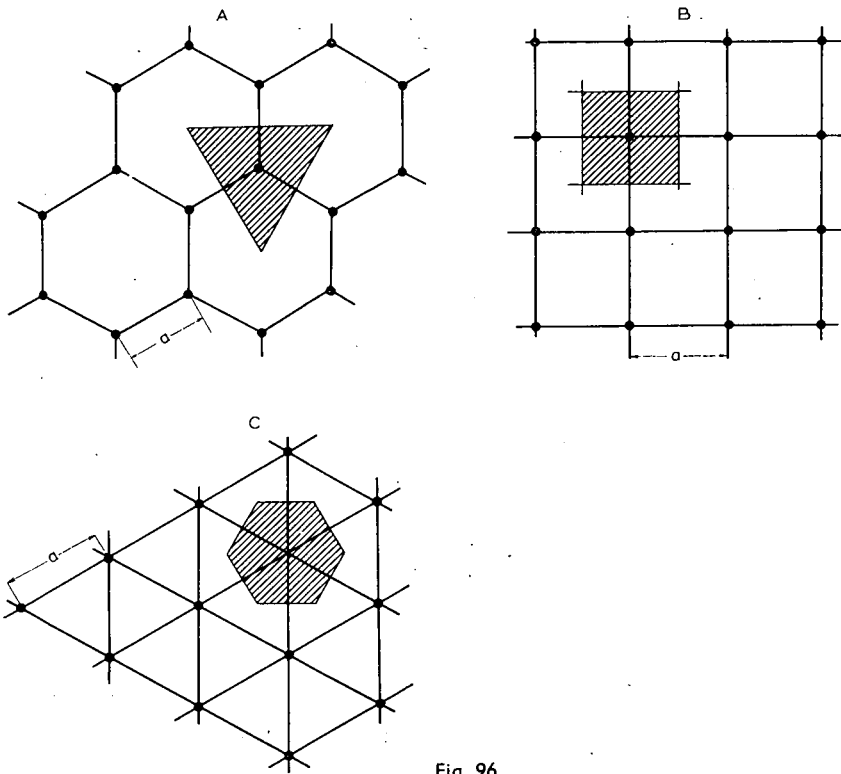

Fig. 96

7.1.2 Different nets

Figure 96. – The triangular system, which was chosen for the example, is one of three possibilities A, B and C. In each of these instances each nodal point of the net is surrounded by respectively 3, 4 or 6 other nodes at equal distances. The nodal points represent the centres of elementary areas S (shaded) of such a form that they fit together and cover the whole aquifer. The scale of the figures has been so chosen that S is equal in the three cases. The distances a between the points are respectively defined by:

$$\text{System A: } a^2 = \frac{4}{9} \sqrt{3} S = 0,768 S$$

$$\text{System B: } a^2 = S = 1,000 S$$

$$\text{System C: } a^2 = \frac{2}{3} \sqrt{3} S = 1,15 S$$

Each system has its advantages and disadvantages:

- In System A and C the nodes are aligned in three directions, which facilitates the adaptation of the net to arbitrary boundaries of the aquifer. In System B, they are aligned in two directions only. Clearly, System B has advantages if the boundaries are actually rectangular, as may occur in academic problems.
- In Systems A and C each node is surrounded by 3 or 6 nodes at the same distance, while in System B the four nodes used in the calculation are at short distance, and the four others, not used, are at slightly greater distance. The system lacks elegance.
- The hexagons of System C approach the circular form, which enables comparison with radial flow problems.

In the following sections only System C will be considered.

7.1.3. Various difference equations

Constant D

For steady flow in an aquifer with constant D the following equation can be established

$$\frac{\partial^2 \phi}{\partial x^2} + \frac{\partial^2 \phi}{\partial y^2} = N$$

by eliminating q_x and q_y , between the law of linear resistance and the law of continuity (see Section 1.3.2). If n is given, N is determined by

$$N = n$$

independent of ϕ . If in the case of a partly confined aquifer, ϕ' is given, N is determined by

$$N = \frac{k'}{D'} (\phi' - \phi)$$

dependent on ϕ .

Figure 97: - Since the formula is a differential equation, it establishes the relation between ϕ in a certain point and in adjacent points at infinitely small distances. For numerical methods a similar relationship can be established, which relates ϕ in the nodal point M to the ϕ values in the six surrounding nodes A, B, ... F, at small, but finite distances. The term 'difference equation' is used for this relationship. In its general form it reads, when n is given:

$$(1) \quad \phi_M = \frac{\Sigma \phi_A + c}{6}$$

Where $\Sigma \phi_A$ denotes $\phi_A + \phi_B + \dots \phi_F$, and

$$c = \frac{3}{2} \frac{a^2}{kD} n$$

Fig. 97

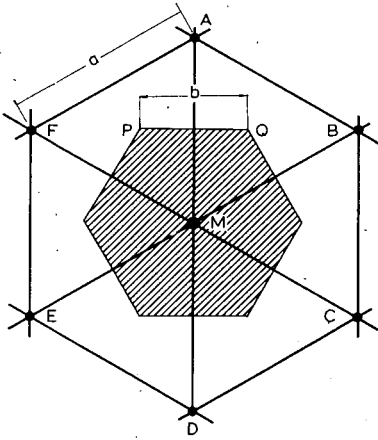

Thus, for $n = 0$, the formula assumes the form

$$\varphi_A = \frac{\Sigma \varphi_A}{6}$$

which is the law of the average, used in the example of Section 7.1.1. If in a partly confined aquifer φ' is given, the difference equation assumes the form

$$(2) \quad \varphi_M = \frac{\Sigma \varphi_A + \varphi'_M d}{6 + d}$$

where

$$d = \frac{3}{2} \frac{k'D'}{kD} a^2$$

The derivation starts from the assumption that the elementary triangles are so small that the linearization usual in the establishment of differential equations is valid as an approximation. The flow passing through PQ is

$$Q_A = kDb \frac{\varphi_M - \varphi_A}{a}$$

where $b = \frac{1}{3} a \sqrt{3}$. When similar expressions for the flows through the other side of the shaded hexagon are established and added, the total flow leaving the shaded prism is found to be

$$\Sigma Q_A = \frac{1}{3} \sqrt{3} k D (6\varphi_M - \Sigma \varphi_A)$$

For given n , in steady flow conditions, this rate equals the volume of water nS , received per unit time on the shaded area S , where $S = \frac{1}{2} \sqrt{3} a^2$. Thus

$$\frac{1}{2} \sqrt{3} a^2 n = \frac{1}{3} \sqrt{3} k D (6\varphi_M - \Sigma \varphi_A)$$

which corresponds to Formula (1).

In problems of a partly confined aquifer with given φ' , the volume of water received per unit time on the shaded area S is $\frac{k'}{D'} S(\varphi'_M - \varphi_M)$ which, equated to ΣQ_A gives Formula (2).

The meaning of the difference equation may be illustrated by replacing the potential φ by the piezometric height h , which differs from φ by a factor γ only. The varying value of h over the area of the aquifer corresponds to a surface, which at the boundaries coincides with the given values of h . If, in the simplest case, $n = 0$, h_M at each point represents the average of the surrounding values, which means that the h surface is like an elastic sheet, fixed along the boundaries and stretched tightly over the area. If n is uniformly positive (recharge), h_M at each point is slightly higher than the average of the surrounding values: the sheet assumes a slightly convex form, as if blown up from below. If n is uniformly negative (evaporation), the sheet assumes a hollow form. Since the river slopes down towards the lake and the surface of the lake itself is horizontal, the h surface, convex or concave, shows the same trend of sloping down towards the lake and approaching symmetry in its cross-sections (parallel to the lake), if the levels in the river branches are about equal.

It is because of considerations of this kind that iteration methods are more instructive than mathematical analysis: the engineer is in direct contact with the properties of the flow system.

Variable D

In problems of steady flow in phreatic aquifers, where the variations of D are considered, the reference level is laid at the base of the aquifer. The difference equation becomes

$$\varphi_M^2 = \frac{\Sigma \varphi_A^2 + c}{6}$$

where $c = 3\gamma a^2 n/k$. The iteration method is applied to the squares of φ instead of the values of φ themselves.

Taking up the proof from the beginning, the horizontal flow between M and A is

$$Q_A = kDb \frac{\varphi_M - \varphi_A}{a}$$

where D is the average thickness of the aquifer between M and A, that is

$$D = \frac{1}{\gamma} \frac{\varphi_M + \varphi_A}{2}$$

Substituting this value of D in the above equation gives

$$Q_A = \frac{kb}{2a\gamma} (\varphi_M^2 - \varphi_A^2)$$

After summation over the six points

$$\Sigma Q_A = \frac{kb}{2a\gamma} (6\varphi_M^2 - \Sigma \varphi_A^2)$$

This off-flow is restituted by the recharge nS on the area S of the hexagon, thus

$$nS = \frac{kb}{2a\gamma} (6\varphi_M^2 - \Sigma \varphi_A^2)$$

which corresponds to the given formula.

The same result can be obtained if, in the formula for constant thickness, φD is replaced by $\varphi^2/2\gamma$.

Two-fluid system

Similar substitutions may be applied to obtain the formulas for φ in steady two-fluid systems with stationary salt water. The two following cases have to be distinguished, where commonly

$$\varphi_M^2 = \frac{\Sigma \varphi_A^2 + c}{6}$$

but for different values of c .

- In the case of a phreatic aquifer, when the reference level is laid at sea level ($\varphi'' = 0$),

φ^2 of the previous case may be replaced by $\frac{\gamma''}{\gamma'' - \gamma} \varphi^2$, which gives

$$c = \frac{3 \gamma (\gamma'' - \gamma) a^2 n}{\gamma'' k}$$

- In the case of a confined or partly confined aquifer, when n is given, independent of φ , φ^2 may be replaced by $\frac{\gamma}{\gamma'' - \gamma} \varphi^2$ if the reference level is chosen at a distance $\frac{\gamma''}{\gamma} a_3$ above the top of the aquifer, where a_3 is the elevation of the sea level above the top of the aquifer. Then

$$c = 3(\gamma'' - \gamma) a^2 n / k$$

Once the values of φ at the points of the net are determined by means of the iteration method, those of h and Z can be found by means of the formulas given in Section 6.2.3. The corresponding problem for a partly confined aquifer where φ' is given will not be treated here, since the difference equation is not linear and would not form a good basis for an iteration method, where the elementary operation should be simple. In the cases of a one-fluid system with variable D or a two-fluid system, the flow section may reduce to zero at the boundary, which is even the rule along the coast in a two-fluid system. Although φ shows a singularity at the boundary, φ^2 is analytic. Therefore, mathematically the iteration may be applied on the value of φ^2 , without restrictions, although physically the border strip requires a detailed examination (see Sections 3.2 and 6.2.2).

7.1.4 Improved procedures

In this section some improvements of the iteration method will be discussed. There are two reasons for doing this. First the method given in the example of Section 7.1.1 is not the most rapid. This argument is relevant when the operations are executed by hand, but loses importance in computer programs, where it is simplicity, rather than rapidity, that counts. Secondly there is an interest in showing some variation in the procedure: more insight is gained and a better basis is laid for considerations on convergence.

The example will be given for fresh water flow in a partly confined aquifer where φ' is given in each node, which is one of the most complicated problems studied. The difference equation reads:

$$\varphi_M = \frac{\sum \varphi_A + d \varphi'_M}{6 + d}$$

where

$$d = \frac{3}{2} \frac{k' / D'}{kD} a^2$$

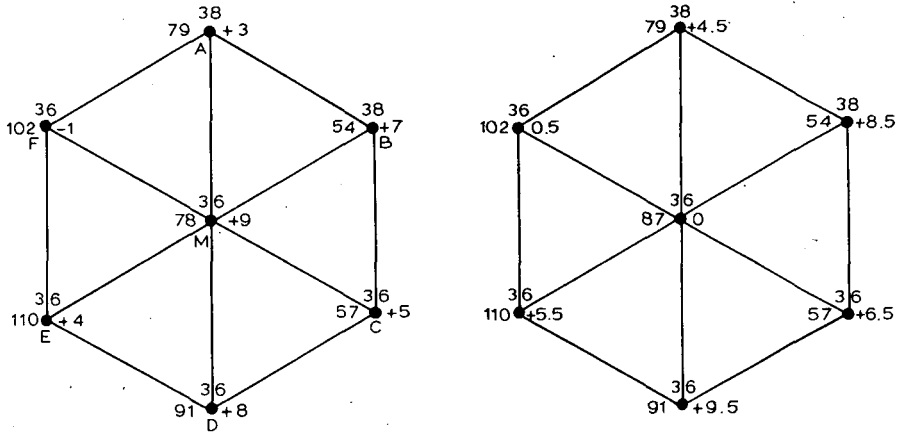

Fig. 98

Figure 98. – This net is drawn in ink on thick paper and on a large scale. Above each node, in ink as well, the local value of φ' is indicated; to the left in lead pencil the estimated value of φ ; to the right, also in lead pencil, the correction, positive or negative, to be added to the value of φ to bring this value into agreement with the surrounding values, according to the difference equation. This correction is calculated and indicated, but not yet added to the value of φ .

Then, node after node, the corrections are added. This is done in the following way (the left-hand figure shows the position before the corrections are added, the right-hand figure the position after):

– Add the correction $+9$ to the φ value of 78 at M , by rubbing out the value 78 and replacing it with $87 (= 78 + 9)$; rub out the correction $+9$ at M and replace it with zero.

– Still a secondary correction is required, for the following reason. When at A the correction $+3$ was calculated, the value $\varphi = 78$ at M was used. Once this value has been changed (increased by 9), the correction at A should be changed accordingly

adding $\frac{9}{6+d}$, or about $1,5$ if d is small compared with 6 . This must be done at the six nodal points surrounding M .

To obtain rapid results by hand, the points are taken in an irregular succession, giving priority to nodes with high corrections, especially when they are surrounded by corrections of the opposite sign. The secondary correction then totally or partly cancels out the values noted in the surrounding nodes. If in the beginning all corrections have the same sign, this means that the values of φ have been estimated generally too high

or too low. It may then be more efficient to start again from scratch with another estimate.

Instead of adding the whole value of the correction one can better add a multiple of $6 + d$, so as to avoid accumulation of errors by rounding off. A part of the correction then remains indicated on the right-hand side of the nodal point. In zones where all the signs are alike, the desired variation in sign may be created artificially by applying too high a correction to some points.

These remarks do not exhaust the matter: other methods to speed up the operation may exist. In the case of mechanical computation still other ways may be followed.

It can be deduced from the above that the method converges. Even if all the corrections have the same sign, a correction p at M is replaced by six others, each equal to $p/(6 + d)$ and with the same sign. Thus the sum S of the absolute values of all corrections decreases at every elementary operation. But since d is small in comparison with 6, and in some problems zero, the effect is small or nil. Yet, even if the corrections are uniformly of the same sign and $d = 0$, the sum S decreases each time a node adjacent to the boundary is treated, since at the border nodes no secondary corrections are added. Continuous decrease of the sum S of the absolute values of the corrections means convergence of the method, since S cannot drop below zero and cannot stop at another limit either, the solution being unique.

The question then arises as to how long the calculation should be continued. Although at all times and for any node the drawing shows the correction still to be added, it does not answer the question. The correction still to be added is comparable to the next term in a series, which is not equal to the rest term.

To answer this question physical considerations may be used. Each set of φ values in the nodes of the net corresponds to a true flow pattern, but with k'/D' or φ' values different from those defining the problem. Thus the same equation

$$\varphi_M = \frac{\Sigma \varphi_A + d\varphi'_M}{6 + d}; \quad d = \frac{3}{2} \frac{k'/D'}{kD} a^2$$

may be used to translate the corrections still to be added into differences with the given k'/D' or φ' values. If these differences are within the limits of precision admitted for these quantities, the operations can be terminated. In problems where n is given, the corrections may be translated in differences of n .

7.1.5 Wells in the field

The theory given is based on the assumption that the elementary triangles cover small areas in which φ and q are continuous functions of the coördinates. This condition is not satisfied in the vicinity of a well. Therefore special methods must be developed to

deal with problems where water is extracted from one or more wells.

Figure 99. – The example given will be that of an aquifer with constant D , surrounded by a boundary with given values of φ . The recharge n of the aquifer is given in each node of the net. Two wells extract water at rates Q_1 and Q_2 respectively.

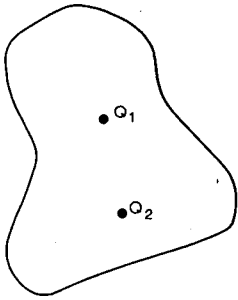

Fig. 99

The solution can be found by superposing the following elementary systems:

System I, characterized by:

- The first well, extracting at a rate Q_1 , sited in an infinite aquifer.
- Arbitrary value φ_1 of the potential in the well.
- No recharge ($n = 0$).

This is the system where φ varies with the logarithm of the distance to the well. The logarithmic function gives the values φ_1 of φ at the nodes of the boundary (see Section 2.3.1).

System II is similar to System I, but applies to the other well. It defines the values φ_{II} of φ at the nodes of the boundary.

System III:

- No extraction from the wells.
- The true values n of the recharge in each node of the net.
- Potentials in the nodes of the boundary equal to

$$\varphi_{III} = \varphi_t - (\varphi_I + \varphi_{II})$$

where φ_t are the true values.

This system can be calculated by iteration, since φ is a continuous function of x and y . The singularities have been limited to Systems I and II, where exact integration accounts for them.

It can readily be shown that the solution is independent of the arbitrary choice of φ_1 and φ_2 . If $\varphi_1 - x$ had been chosen instead of φ_1 , all φ values in System I would have been lower by a quantity x , hence also the values φ_I at the boundary nodes. Thus the φ_{III} values would have been that much higher, and the x terms would have cancelled out in the superposition of Systems I and III.

The same principle may be applied to phreatic aquifers or to two-fluid systems. The superposition must then be executed by adding the values of φ^2 .

7.2 NUMERICAL METHODS WITHOUT ITERATION

In this following section some examples will be given of the use of the same network in numerical methods without iteration. They may be used independently or in combination with iteration methods, and can be applied to either steady or nonsteady flow problems. Thus the variety of possible applications is very great, and covers most of the problems that can be posed in the categories examined in this study. The operations may be long, but computers can be used.

Long calculations are especially to be expected when a nonsteady movement is followed over a long series of elementary time intervals Δt . Since, however, the movement of the interface is generally very slow, the elementary time interval Δt might be of the order of the period in which the new works are written off through depreciation – some 30 or 50 years – in which case the calculation of one interval might suffice to examine the feasibility of a technical execution.

The problem is not always defined in an academic way. Studies on limited areas, not reaching to the boundaries of the aquifer, can be made if sufficient data are available from measurements. From measured values of φ'' and Z for instance, as will be shown, the movement of the interface can be deduced in any limited region.

In other cases the data known from measurement may be over-abundant. The numerical methods can then be used in the reverse sense: when for instance in each hexagon the individual values of n or k'/D' are calculated, the assumed uniformity of these quantities is checked.

It is not the aim of this publication to work out operation methods for complicated problems; only some principles are given, illustrated by some examples.

7.2.1 Steady flow in a partly confined aquifer (one fluid)

Figure 100. – Section 4.2.4 dealt with parallel steady flow in a partly confined aquifer where φ' was given graphically, as indicated in the upper figure. One possible method of calculation was the superposition of elementary systems, as represented in the lower figures.

Figure 101. – The same principle can be followed if φ' is given in the nodes of a net, within a closed boundary, while outside that boundary $\varphi' = 0$ to infinity. Such an arrangement might well be an element in a system of superposition, accounting for the rise or fall of the phreatic aquifer due to irrigation or drainage in a given region.

The system can be considered as the sum of a series of elementary systems, each defined by the value φ'_A in one of the hexagons (A, shaded), and $\varphi' = 0$ all around. Each elementary system can be calculated by replacing the hexagon with a circle of

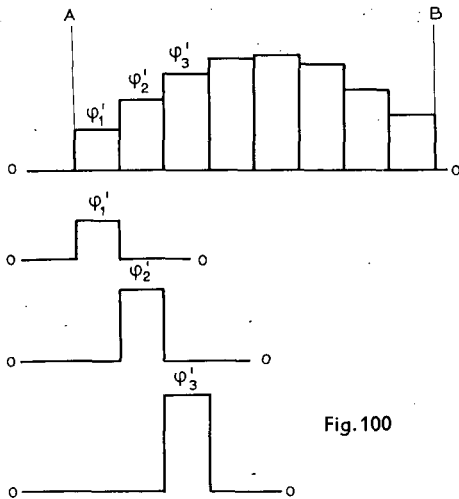

Fig. 100

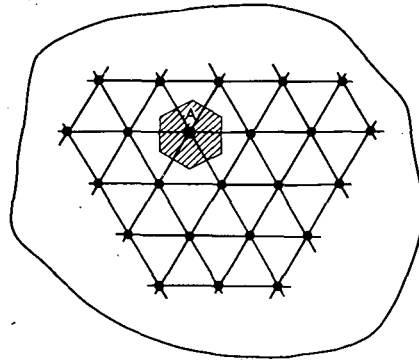

Fig. 101

the same area, which gives a close approximation. The problem then reduces to that of Section 4.3.2. With the formulas of this section, for $\varphi' = 1$ in the central hexagon, the φ values in the surrounding points of the net can be calculated. A tracing paper can be prepared, representing the nodes of the net, with the hexagon in question in the middle and the calculated φ values written under the points.

If now, on the original drawing, the φ' values are indicated above each point, the combined influence of all hexagons at a point P can readily be calculated by laying the central node of the tracing paper at P. Above and below a point A within the boundary are then read respectively

- φ'_A , which is the given value of φ' at A and
 - φ_{MA} , which is the φ value at A, due to $\varphi' = 1$ in the elementary hexagon around P.
- But the influence at A of a hexagon at P is the same as the influence at P of a hexagon at A: in formula: $\varphi_{MA} = \varphi_{AM}$. Thus the two papers laid one on the other show for any point A, written one above the other, φ'_A and φ_{AM} , whose product is the φ value at P due to the hexagon around A. When taking $\Sigma \varphi'_A \varphi_{MA}$ over all points within the boundary, the φ value at P is found. For another point Q the calculation is then repeated, placing the centre of the tracing paper on Q, etc.

7.2.2 Nonsteady flow

One-fluid system; phreatic aquifer

In a phreatic aquifer surrounded by water courses the most general steady flow system is defined by

- The φ values at the boundary points, as functions of time.
- The n values at the points of the field, as functions of time.
- The φ values at the field points as an initial condition.

From these data $\partial\varphi/\partial t$ in the first time interval can be calculated for each field point, and thus $\Delta\varphi$ from

$$\Delta\varphi = \frac{\partial\varphi}{\partial t} \Delta t$$

which gives the φ values as an initial condition for the next interval Δt . The calculation can then be repeated. A systematic error is made since the values of the beginning of the interval are taken instead of the average over the interval. It is difficult to avoid this inconvenience without compromising the simplicity of the method. The propagation of parallel sine waves through a net of squares with sides Δx may be analysed to show that both Δx and Δt are bound to an upper limit if the form and the velocity of the waves is to be found correctly.

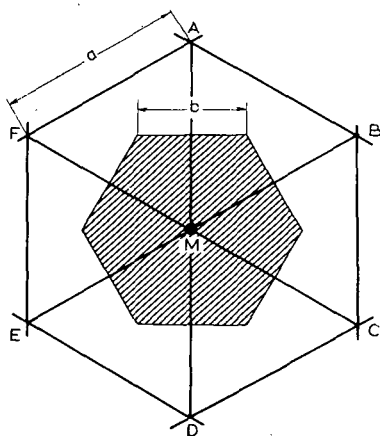

Fig.102

Figure 102. - The calculation can be made for each hexagon separately according to

$$\mu \frac{\partial\varphi}{\partial t} = n - \frac{2}{3} \frac{kD}{a^2} (6\varphi_M - \Sigma\varphi_A)$$

if D is considered as a constant; or according to

$$\mu \frac{\partial\varphi}{\partial t} = n - \frac{k}{3\gamma a^2} (6\varphi_M^2 - \Sigma\varphi_A^2)$$

if D is considered as a variable, in which case the reference level must be laid at the bottom of the aquifer.

The water balance of an elementary prism is established. The outward flow through the six sides is

$$\Sigma Q_A = \Sigma k D b \frac{\varphi_M - \varphi_A}{a}$$

where $b = 1/3 a \sqrt{3}$ and Σ denotes the sum over A, B, ... F. Otherwise written:

$$\Sigma Q_A = 1/3 \sqrt{3} k D (6\varphi_M - \Sigma\varphi_A)$$

This flow equals the sum of the quantities of water received from recharge and released by a lowering of the surface over the shaded area S per unit time, or

$$\Sigma Q_A = S \left(n - \mu \frac{\partial \varphi}{\partial t} \right)$$

where $S = \frac{1}{2} a^2 \sqrt{3}$. It follows that

$$\mu \frac{\partial \varphi}{\partial t} = n - \frac{2}{3} \frac{k D}{a^2} (6\varphi_M - \Sigma\varphi_A)$$

For variable D the derivation is similar.

Two-fluid system; phreatic aquifer

The next problem bears a great resemblance to the previous one. The model represents an island of irregular form, containing a phreatic aquifer and surrounded by the sea. The flow system in very general conditions is defined by:

- The constant potential in the sea (reference level at sea level, $\varphi'' = \varphi = 0$ along the coast).
- The n values in the field points, varying in an irregular way with time.
- The elevation of the phreatic level, h , at each field point, as an initial condition.
- The elevation of the interface, Z , at each point, also as an initial condition.

Figure 103. - The values of h determine those of φ , according to

$$\varphi = \gamma h$$

The values of φ and Z determine those of φ'' according to

$$\varphi - \varphi'' = -(\gamma'' - \gamma)Z$$

From these data $\frac{\partial h}{\partial t}$ and $\frac{\partial Z}{\partial t}$ can be found for each point of the field from

$$(1) \quad m \frac{\partial Z}{\partial t} = -\frac{2}{3} \frac{k D''}{a^2} (6\varphi''_M - \Sigma\varphi''_A), \quad \text{and}$$

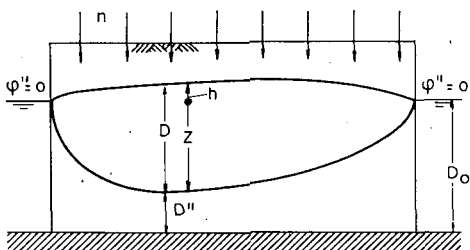

Fig. 103

$$(2) \quad m \frac{\partial h}{\partial t} = n + m \frac{\partial Z}{\partial t} - \frac{2}{3} \frac{kD}{a^2} (6\varphi_M - \Sigma\varphi_A)$$

where $D'' = D_0 + Z$ (Z negative) and $D = -Z + h$

Then the values of h and Z at the beginning of the new interval can be found, and the operation repeated.

Equations (1) and (2) are the mathematical expression of the water balance of elementary hexagonal prisms around node M , with heights of D'' and D respectively. Contrary to the previous derivations, the flow sections on the six sides have been given the heights D'_M and D_M , respectively in the fresh and salt water layer. If in each water layer six different values had been distinguished, the formulas would have been complicated.

The water balance of the prism of height D''_M is given by

$$-m \frac{\partial Z}{\partial t} S = \Sigma kbD''_M \frac{\varphi''_M - \varphi''_A}{a}$$

corresponding to Equation (1). The balance over the height D_M is given by

$$n = -m \frac{\partial h}{\partial t} S + m \frac{\partial Z}{\partial t} S = \Sigma kbD_M \frac{\varphi_M - \varphi_A}{a}$$

corresponding to Equation (2). The left sides give the quantities supplied to the prism by the recharge and the displacements of surface and interface, where $S = 1/2 a^2 \sqrt{3}$ is the area of the hexagon. The right members give the outflow through the six sides, where $b = 1/3 a \sqrt{3}$ is the breadth of the sections.

For the border points, where the flow section reduces to zero, reference is made to Section 7.1.3.

Two-fluid system; partly confined aquifer

Figure 104. – A similar problem can be posed for a partly confined aquifer: to calculate the transformations of the fresh-water body under an island, under the influence of given φ' values (constant or variable with time), beginning with a given shape of the interface. The sea level corresponds to φ_1'' .

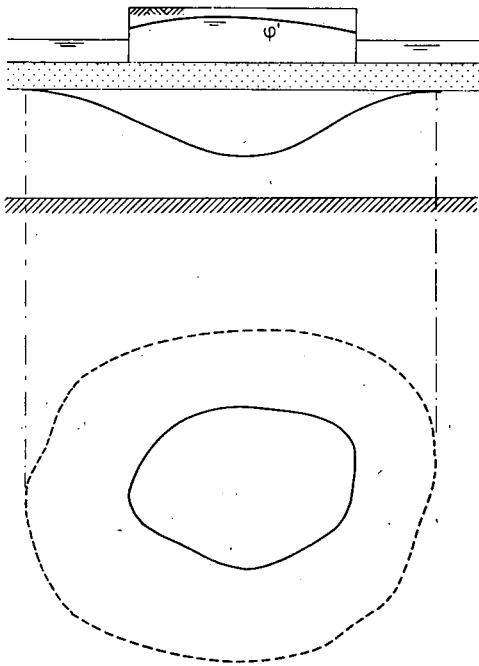

Fig. 104

This problem has been treated in Section 6.3.3 for parallel flow. It will not be repeated here in detail; the main points of the method will merely be indicated.

Two systems with the same interface are superposed for each time interval Δt . System I is characterized by steady flow, and $\varphi'' = \varphi_1''$ in the salt water layer. From Z and φ'' , φ is calculated according to

$$\varphi'' - \varphi = -(\gamma'' - \gamma)Z$$

The equation

$$\frac{2}{3} \frac{kD}{a^2} (6\varphi_M - \Sigma\varphi_A) = N$$

accounting for the water balance in an elementary prism over the height D of the fresh-water body enables N to be calculated for each node of the net. Then

$$N = \frac{k'}{D'} (\varphi' - \varphi)$$

gives φ' , since N and φ are known. This value, φ'_I , is different from the true value, φ'_{III} , (which may vary from one interval to another).

Thus System II is defined by φ' values

$$\varphi'_{II} = \varphi'_{III} - \varphi'_I$$

and further by homogeneous water, and $\varphi'' = 0$ in the sea. It can be calculated as indicated in Section 7.2.1. As a result the values of N can be established in each hexagon, and then those of $\frac{\partial Z}{\partial t}$ from

$$\frac{\partial Z}{\partial t} = - \frac{D''}{D_i} \frac{N}{m}$$

(see Section 6.3.2). Thus the Z values at the beginning of the next time interval can be evaluated and the calculation repeated for the next interval.

The calculation is rather long; moreover there is the inconvenience that the initial form of the under-water part of the fresh-water body is difficult to establish by borings and difficult to calculate. Finally the extremity of that body moves, which causes slight complications, since the movement in a time interval Δt generally does not correspond to the advancement from one point of the net to another.

In contrast, very simple calculations can be made for the island itself or a part of it, when data are known from measurements. When φ and Z are known at each point, φ'' can be calculated from

$$\varphi - \varphi'' = - (\gamma'' - \gamma)Z$$

and $\frac{\partial Z}{\partial t}$ from the waterbalance of the salt water part of the elementary prism

$$\frac{\partial Z}{\partial t} = - \frac{2}{3} \frac{kD''}{a^2 m} (6\varphi''_M - \Sigma\varphi''_A)$$

To give another example, if in a limited area the water levels (defining φ') are raised or

lowered by irrigation or drainage, the influence can be calculated from the homogeneous fluid system discussed in Section 7.2.1. In particular, the change of N at each node of the net inside or outside the project area can be found. At any point where Z is known from measurements the change in $\frac{\partial Z}{\partial t}$, due to the executed works, can be found from

$$\Delta \frac{\partial Z}{\partial t} = - \frac{D''}{Dt} \frac{\Delta N}{m}$$

As a final example, if for constant φ' values in a limited area, φ' and φ at each node are known from measurements, a check can be made on the assumed values of n and k'/D' , applying

$$\frac{k'}{D'} (\varphi' - \varphi) = n$$

for each node of the net separately.

BIBLIOGRAPHY

- ANONYMOUS (1964): Steady flow of groundwater towards wells: compiled by the Hydrologisch Colloquium; Proceedings Comm. Hydr. Research TNO, No. 10, The Hague, 179 pp.
- ANONYMOUS, (1966): Groundwater and wells. Edw. E. Johnson, Inc. St. Paul, ...pp.
- BEAR, J., D. ZASLAVSKY and S. IRMAY (1968), Physical principles of water percolation and seepage. Arid Zone research XXIX, UNESCO, Paris, 465 pp.
- CASTANY, G. (1963): Traité pratique des eaux souterraines, Dunod, Paris, 657 pp.
- COOPER, H. H. et al. (1964): Sea water in coastal aquifers. U.S. Geol. Surv. W.S. paper No. 1613-C, Washington, 84 pp.
- DAVIS, S. N. and R. J. M. DE WIEST (1966): Hydrogeology. John Wiley and Sons, New York, 463 pp.
- DE WIEST, R. J. M. (1965): Geohydrology. John Wiley and Sons, New York, 366 pp.
- FERRIS, J. G. et al. (1962): Theory of aquifer tests; U.S. Geol. Surv. W.S. paper No. 1536-E, Washington 174 pp.
- HARR, M. E. (1962): Groundwater and seepage. McGraw-Hill, New York, 315 pp.
- JACOB, C. R. (1940): On the flow of water in an elastic artesian aquifer; Trans. Am. Geophys. Union Vol. 21. pp. 574-586.
- JAHNKE, E. and F. EMDE (1945): Tables of functions with formulae and curves, 4th ed. Dover Publications, New York, 306 pp.
- KAZMANN, R. G. (1965), Modern hydrology. Harper and Row, New York, 301 pp.
- LUTHIN, J. N. (ed.) (1957): Drainage of agricultural lands; Agronomy Vol. VII; Am. Soc. Agronomy, Madison, 620 pp.
- MUSCAT, M. (1946): The flow of homogeneous fluids through porous media; 2nd printing, Edwards Inc., Ann Harbor, 763 pp.
- POLUBARINOVA-KOCHINA, P. YA. (1962): Theory of groundwater movement; Princeton University Press, Princeton, 613 pp.
- ROUSE, H. (ed.) (1950): Engineering Hydraulics. John Wiley and Sons, London, 1039 pp.
- SCHOELLER, H. (1962): Les eaux souterraines; Masson et Cie, Paris, 642 pp.
- SOUTHWELL, R. V. (1946-1956): Relaxation methods in theoretical physics Vol. I and II. Clarendon Press, Oxford, 248 and 522 pp.
- TODD, D. K. (1959): Groundwater hydrology; John Wiley, London, 335 pp.
- TOLLMAN, C. F. (1937): Groundwater. McGraw-Hill, New York, 593 pp.
- VEN TE CHOW (ed.) (1964): Handbook of applied hydrology; McGraw-Hill, New York, 1418 pp.
- WISSLER, C. O. and E. F. BRATER, (1958): Hydrology; 6th Ed.; John Wiley, New York, 419 pp.