

Effects of pH and Additives on Aqueous Wetting Films Stabilized by a Triblock Copolymer*

O. V. Eliseeva,^a N. A. M. Besseling,^{b,**} L. K. Koopal,^a and M. A. Cohen Stuart^a

^aLaboratory of Physical Chemistry and Colloid Science, Wageningen University, Dreijenplein 6, 6703 HB Wageningen, The Netherlands

^bSection NanoStructured Materials, Department of Chemical Engineering, Delft University of Technology, Julianalaan 136, 2628 BL Delft, The Netherlands

RECEIVED JUNE 14, 2006; REVISED MAY 29, 2007; ACCEPTED JUNE 4, 2007

Keywords
aqueous wetting films
disjoining pressure
water-soluble polymers
block copolymer
surfactants
salting-in
salting-out

Effects of pH and additives (NaCl, Na₂SO₄, NaSCN and urea) on the adsorption of an ABA triblock copolymer (F127) with polyethylene oxide as the A blocks and polypropylene oxide as the B blocks, at the interfaces of wetting films, on film drainage and on the interaction forces in these films are examined using ellipsometry and a thin film balance technique. The influence of these additives on micellization are studied by static light scattering. The main findings are that all additives reduce the adsorption at the silica surface and retard the film drainage. Moreover, high pH values (≈ 10) destabilize the wetting film if 0.1 mol dm⁻³ NaCl is present. The reduction of the adsorbed amount appears to be correlated with a dramatic slow down of film drainage. The slow drainage as well as the destabilization of the film is attributed to bridging attraction between a densely covered air-water interface and a very sparsely covered silica-water interface.

INTRODUCTION

The problem of wetting film stability on a solid is important in numerous technical processes, such as cleaning and mineral flotation, and products like windows and textile fibers. We consider here the stability of aqueous wetting films on silica. In simple cases, the main forces controlling the stability of aqueous wetting films are repulsive electrostatic and Van der Waals forces. Since the potential of the clean air-water interface is negative¹ and also the silica-water interface is at neutral pH negatively charged² the electrostatic interaction between the solid-liquid and liquid-gas interfaces is clearly repulsive. Moreover, the Van der Waals force is also necessarily repulsive (Hamaker constant $A_{\text{silica/water/air}} = -10^{-20}$ J).³ In

addition, it may occur that there are attractive hydrophobic forces between the solid-water and air-water interface.^{4,5} If the film forms from an aqueous polymer solution, an important contribution comes from the polymer-induced forces: steric, bridging and depletion forces.^{6,7} When the polymer adsorbs, the properties of the adsorbed layers become crucial. The total force induced by such polymer layers results from a balance between several interactions.⁷ When the polymer is in a good solvent, the force between the interfaces may have a steric repulsive component due to the excluded volume repulsion between the two adsorbed layers, but it can also have an attractive component due to the formation of polymer bridges between the two surfaces. If the adsorption is irreversible on the relevant time scale, and the surfaces

* Dedicated to Professor Nikola Kallay on the occasion of his 65th birthday.

** Author to whom correspondence should be addressed. (E-mail: N.A.M.Besseling@tudelft.nl)

of the film are saturated with polymer, steric repulsion is dominant and polymer layers stabilize the film. If the interfaces are not saturated with polymer, bridging attraction may become dominant and the polymers can induce a destabilization of the film.

The effect of polymers on the forces between two identical surfaces has been amply studied. The case of wetting films is more complicated due to the asymmetry of this system. Only a few publications and reviews on wetting films formed by aqueous solutions of polymers are available.^{4,5,8–12} In our previous studies we observed an unexpected effect of NaCl on the thickness and drainage of aqueous wetting films, stabilized by the triblock copolymer Pluronic F127.^{11,13} We attributed this effect to changes in the solubility of the triblock copolymer, which becomes worse upon addition of electrolyte. In theoretical treatments the behavior of polymers at an interface is usually characterized by two interaction parameters, one for the free energy of mixing polymer and solvent (χ), and one for the free energy associated with the formation of polymer-surface contacts and concomitant breaking of surface-solvent contacts (χ_s).¹⁴ For our system of PEO-PPO-PEO triblock copolymers adsorbing from water onto two different surfaces (silica/water and air/water) we have three χ parameters ($\chi_{\text{PEO/water}}$, $\chi_{\text{PPO/water}}$, and $\chi_{\text{PPO/PEO}}$) and four χ_s parameters (one for each monomer/interface combination). Changing pH or adding additives to aqueous solutions may change any of these parameters, thereby affecting the properties of the film.

It is the purpose of the present investigation to assess the role of polymer-mediated surface forces on the stability and thickness of wetting films on silica. Accordingly, we consider: (1) effects of additives on the behavior of F127 in aqueous solution, (2) effects of pH and additives on the adsorption of F127 at silica-water and air-water interfaces, and (3) effects of pH and additives on wetting films: polymer-induced forces, drainage and wetting behavior.

EXPERIMENTAL SECTION

Materials

The polymeric surfactant (triblock copolymer) Pluronic F127 (average molecular structure $\text{PEO}_{99}\text{PPO}_{65}\text{PEO}_{99}$, Sigma-Aldrich CO., USA) was used without further purification. Pluronic F127 has a number average molar mass, M_n of 12600 and a PEO content of 70 % by weight. Aqueous solutions of F127 were prepared by dissolving the polymer in demineralised water under gentle agitation. Sodium chloride, NaCl, sodium sulfate, Na_2SO_4 , sodium thiocyanate, NaSCN and urea, $(\text{NH}_2)_2\text{CO}$ (purity min. 99.99 % supplied by J.T. Baker Chemicals B.V., Holland) were used without further purification. The water used was purified using a

»Barnstead EASY pure UV« machine to produce water with a resistivity of 18 M Ω cm.

Polished silicon plates, Si (p-type, boron-doped, oriented <1–0–0>, resistivity 12–18 Ω cm) were purchased from Wafer Net, Germany. The thickness of the natural silicon oxide SiO_2 layer on the surface was about 2 nm, as determined by ellipsometry. Wafers were cut into small strips and boiled for 5 min at 80 °C in a mixture of 25 % NH_3 , 30 % H_2O_2 and H_2O (1:1:5 by volume). The strips were then rinsed with water and ethanol (99.8 %). They were kept in a closed container under water until use. Before the slices were placed in the cell, they were dried with a stream of nitrogen and treated for 30 seconds in a plasma cleaner (Harrick, Model PDC–32 G). The plasma treatment was performed with air (10 Pa). After cleaning, the contact angle of water was always lower than 8°, indicating the hydrophilic nature of the silicon oxide surface. Measurements were carried out at pH = 6 and $t = 21\text{--}23$ °C unless stated otherwise.

Thin Film Balance (TFB)

The TFB technique based on the original design of Mysels and Jones,¹⁵ is developed and described for wetting films by Shishin and Derjaguin *et al.*^{16,17} A schematic drawing of the TFB used in the current study is given in Figure 1. A thin liquid film is formed on a silica surface (1), in a hole of 0.5 cm drilled in a porous glass disc (2) (Robu, Germany, pore size 4 μm), which is fused to the end of a glass tube (3). The latter is connected to a glass vessel (4), *via* a polyvinylchloride (Rauclair) tube (5). The film holder is placed inside a covered plexiglas cell (6). The Plexiglas cover and the porous discs have narrow channels and grooves for the incident and reflected light beams of the ellipsometer. Some elements of the ellipsometer are shown in Figure 1: the polarizer (P) and the analyzer (A). Details of the ellipsometric data acquisition and processing are given in the ellipsometry section, below. The silica plates and porous glass disc were saturated for a night in a F127 solution before the TFB measurements.

Manipulation of the hydrostatic pressure, by changing the height difference (H) between the silica surface and the

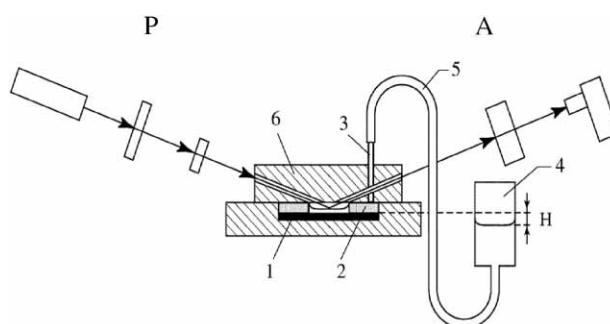

Figure 1. Thin-film balance: (1) silica sample plate, (2) porous glass disc, (3) glass tube, (4) glass vessel, (5) polyvinylchloride (Rauclair) tube, (6) plexiglas cell. Arrows indicate the light beam; (A) analyzer, (P) polarizer.

liquid in reservoir (4), will affect the pressure, Π , in the film. At equilibrium, Π is the disjoining pressure; it is opposite in sign and equal in magnitude to the hydrostatic pressure difference Δp_H :

$$\Pi(h) + \Delta p_H = 0 \quad (1)$$

The hydrostatic pressure difference is given by $\Delta p_H = \rho g H$, where ρ is the liquid density, g is the gravitational acceleration and H the height difference between the silica surface (1) and the reservoir (4). H has negative values as the level in the vessel is below the silica surface, and is measured with a cathetometer (Mitutoyo, Model AT11-N600, Japan). In the film drainage experiments a pressure of -4.5 kPa was applied after which thinning of the film was followed by ellipsometry.

Ellipsometry

We used ellipsometry to measure thicknesses of wetting films in situ in the TFB, as well as for the adsorbed layers at silica/solution and at solution/air interfaces. Background on ellipsometry can be found elsewhere.¹⁸ The ellipsometric angles were determined *via in situ* null ellipsometry. In null ellipsometry, the polarizing elements (polarizer, P, and analyzer, A) are rotated until the signal at the photo-detector is minimized (\gg nulled \ll). A Multiskop instrument (Optrel Gbr, Berlin) controlled by a computer was used for the measurements. The light source was a He-Ne laser with wavelength of 632.8 nm.

Because of some differences between the available porous discs, measurements on thin films were done at angles of incidence varying between 65° and 70° , which is close to the Brewster angle for an air-silicon interface (75°). The thickness of the thin films (h_{film}) was obtained on the basis of a four-layer model {silicon / silicon oxide / aqueous film / air}. In the calculations of the film thickness, predetermined values for the refractive indices of silicon (3.85), silica (1.46), aqueous solution (1.333) and air (1.00), as well as for the thickness of the silica layer (2 nm) were used. Furthermore, it was assumed that the aqueous film is homogeneous, and that the refractive index is the same as that in the aqueous bulk solution, n_{sol} .

Adsorbed layers at silica-solution interfaces were measured in situ in a Teflon cell with glass windows which was filled with the solution of F127 and additives. The thickness of adsorbed layers and adsorbed amounts per unit area were obtained on the basis of a four-layer model as well {silicon / silicon oxide / adsorbed layer / water}. Adsorbed layers at solution-air interfaces were measured in situ, and analysed in terms of a three-layer model: {aqueous solution / adsorbed layer / air}. Details are given in our previous work.¹¹

Although the precise values of the calculated sample parameters such as the adsorbed layer thickness (h_{ads}) or the film thickness (h_{film}) depends on the correctness of the assumed model, trends in these parameters are less sensitive to the model. Correction of the film thickness to account for an internal structure of the film, with adsorbed layers at the interfaces does not significantly alter the results.¹¹ The dis-

joining pressure curves determined this way are always smooth, but their absolute position on the h -axis may have an uncertainty of at most 10–15 %.

Static Light Scattering

Static light scattering (SLS) was used for the characterization of F127 in solution. Light scattering measurements were carried out with the static/dynamic compact goniometer system an ALV/DLS/SLS-5000 (Langen, Germany). The light source was an argon ion laser (Lexel, Palo Alto, CA) emitting vertically polarized light at a wavelength of 514.5 nm. The scattering angle was 90° . Solutions were contained in a cell thermostatted at 22°C .

Contact Angle Goniometry

A drop of liquid was placed on the silica surface and the image of this drop was investigated with a Contact Angle Meter G-1 (Goniometer), Erma Optical works, Ltd., Tokyo, Japan at $t = 22^\circ\text{C}$. The contact angle of water was always lower than 8° , indicating the hydrophilic nature of the silicon oxide surface.

RESULTS AND DISCUSSION

Effects of Additives on the Behavior of F127 in Aqueous Solution

It is known that block copolymers form aggregates of different kinds, depending on the molar mass, block sizes, the solvent composition, and the temperature. The effect of various additives on the aggregation of F127 in aqueous solution has been studied in detail.^{11,19,20} Alexandridis *et al.*²¹ have correlated the effect of salts on micellization of the triblock copolymer with the ionic radius and the heat of solvation of the salts. Because F127 is rather polydisperse (the M_w / M_n ratio is around 1.3 as measured with gel permeation chromatography (GPC) by Nelson *et al.*²²), it is not easy to obtain a sharp c.m.c. value. It is probable that some lower molar mass diblock PEO-PPO is present in the sample.²²

In our present study we used static light scattering (SLS) in order to measure the influence of different types of additives on micellization (c.m.c.) of F127. The slope of scattered intensity *vs.* concentration exhibits a sudden increase at a certain concentration. This concentra-

TABLE 1. The c.m.c. as found by SLS of F127 in 0.1 mol dm^{-3} additive at $\text{pH} = 6$ and $t = 22^\circ\text{C}$

0.1 mol dm^{-3} additive	c.m.c. / $\mu\text{mol dm}^{-3}$
Na_2SO_4	400
NaCl	800
No additive	1400
Urea	1800
NaSCN	2500

tion was identified as the critical micellization concentration (c.m.c.). The results are summarized in Table I.

We can see that Na_2SO_4 and NaCl both shift the c.m.c. to lower values, while urea and NaSCN lead to higher c.m.c.s. Like others,^{21,23,24} we attribute these effects to changes in the χ -parameters (solvent quality) for PEO and PPO blocks, as follows: (i) NaCl and Na_2SO_4 decrease the solubility (increase χ) of the copolymer in water (salting-out), (ii) NaSCN and urea have the opposite effect (salting-in). The salting-out effect of the anions at a given concentration follows the so-called Hofmeister series: $\text{SO}_4^{2-} > \text{Cl}^- > \text{SCN}^-$. Anions with a strong structure-making tendency decrease the c.m.c. This may arise from the repulsive interactions between PPO or PEO on the one hand, and salt ions on the other, leading to a salt-deficit zone around the monomers and competition for hydration water.^{25–27} The increase of the c.m.c. in the presence of urea or SCN^- probably comes from the enhanced solubility of the surfactant's hydrophobic moiety PPO. The PPO can be affected by urea either (1) by breaking the water »structure«, or (2) replacement of water molecules and hydrogen bonding to urea molecules. Which mechanism is dominant is not very clear. A more extensive discussion is given by Alexandridis *et al.*²⁶

Effects of pH and Additives on the Adsorption of F127 at Silica-water and Air-water Interfaces

Having some overview of the effect of additives on the behavior of F127 in aqueous solution, we turn our attention to the effect of these additives as well as that of pH on the adsorption behavior of F127 at the silica-water and air-water interfaces, respectively.

Whether or not adsorption of a given polymer at an interface will occur depends on $-\chi_s$, that is the difference between the Gibbs energy (in units kT) of monomer/surface contacts and that of solvent/surface contacts. If this difference is sufficiently negative (χ_s is positive) adsorption will occur. Adsorbed polymer chains at an interface are often thought to be composed of three types of subchains: trains, which have all their segments in contact with the substrate, loops, which have no contact with the surface and connect two trains, and tails, which are non-adsorbed chain ends. The conformation of a polymer on a surface depends on the polymer concentration, the solvent quality, χ_s and the density and distribution of the active sites at the surface. An extensive discussion is given in Refs. 7 and 14. In our previous work we studied adsorption of F127 at silica-water and air-water interfaces.¹¹ The commonly found very steep initial rise, followed by a plateau, *i.e.*, a high-affinity adsorption isotherm, was observed for both interfaces. However, the plateau values at the silica-water interface were reached at a lower concentration of polymer ($\approx 200 \mu\text{mol dm}^{-3}$) than those at the air-water interface ($\approx 600 \mu\text{mol dm}^{-3}$).

Most likely, F127 adsorbs at the air-water interface *via* hydrophobic PPO groups, the PEO-moieties dangling into the solution. At silica the polymer presumably binds *via* the EO-parts (the ether oxygen of PEO forms H-bonds with silanol groups), forming either some sort of flat structure (at low concentration) or an adsorbed micellar or bilayer structure, driven by hydrophobic interactions between PPO-parts (at higher concentration).

In general, additives may influence polymer adsorption in two ways: (1) they may change the solvent quality (in the present case quantified by $\chi_{\text{PEO/water}}$ and $\chi_{\text{PPO/water}}$), and (2) they may modify the interaction with the surface (quantified by $\chi_{s,\text{PEO}}$ and $\chi_{s,\text{PPO}}$ for both surfaces). With increasing $\chi_{\text{PEO/water}}$ and $\chi_{\text{PPO/water}}$ water becomes a poorer solvent for F127, leading to a higher adsorbed amount.⁷ The higher adsorption in poor solvents comes from the fact that the weaker effective lateral repulsion between segments makes the accumulation at the surface easier. The effect of additives on χ_s is less obvious. For the water/air interface, where hydrophobic desolvation is an important driving force, the effect most probably parallels that of the solvency effect: higher adsorption from a poorer solvent. For the silica/water interface, however, additives may take a role as competitor, which displaces polymer units from the surface. In addition, the adsorption may be affected by surface charging, because this leads to a changing number of active surface sites. One example of that effect is the decrease of adsorption of PEO homopolymer on silica with increasing pH.⁷

Indeed, a decrease of the adsorbed amount of F127 at the silica-water interface was detected upon increasing the pH (see Figure 2). Upon increasing the pH from 3 to 10, Γ drops by a factor of five. A similar decrease in the adsorbed amount was measured when increasing the salt concentration at fixed pH (Figure 3). Moreover, almost no adsorption occurs at high pH in 0.1 mol dm^{-3} NaCl (Figure 2). The same trend is found by others for PEO homo- and block-copolymers.^{28,29} The explanation is that the silanol

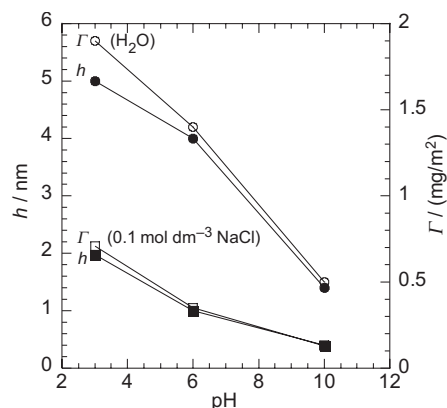

Figure 2. Influence of pH on ellipsometric thickness h and the adsorbed amount Γ of F127 at the silica-water interface in water and 0.1 mol dm^{-3} NaCl . $c_{\text{F127}} = 100 \mu\text{mol dm}^{-3}$, $t = 22 \text{ }^\circ\text{C}$.

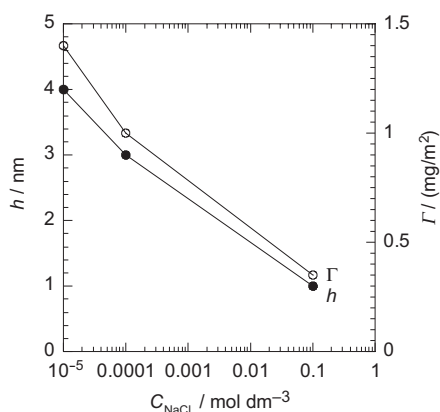

Figure 3. Influence of NaCl on ellipsometric thickness h and the adsorbed amount Γ of F127 at the silica-water interface. $c_{\text{F127}} = 100 \mu\text{mol dm}^{-3}$, $\text{pH} = 6$, $t = 22 \text{ }^\circ\text{C}$.

groups which most likely provide the best adsorption sites, act as proton donors in a hydrogen bond to ether oxygens of the EO groups, *i.e.* $-\text{SiOH}\cdot\cdot\text{O}-(\text{CH}_2-\text{CH}_2)-$.²⁸ The PPO groups might be bound to silica in a similar way (*i.e.* $-\text{SiOH}\cdot\cdot\text{O}-(\text{CH}_2(\text{CH}_3)-\text{CH}_2)-$). Given the hydrophilic nature of silica and the fact that PPO is hydrophobic, it is likely that PEO dominates the surface layer. With increasing pH, the silica surface is progressively deprotonated leading to a decrease in the amount of adsorption sites and adsorbed amount of polymer. A similar mechanism might occur upon increasing NaCl concentration. Na^+ ions accumulate as counter ions near the silica surface, acting as »displacers« competing with PEO segments of the polymer.^{14,30} In order to check this hypothesis, the effect of other salts with the same counter ion (Na_2SO_4 , NaSCN) on the adsorption behavior of F127 at the silica-water interface was studied, and compared with the effect of the non-electrolyte urea ($\text{NH}_2)_2\text{CO}$.

Indeed, a decrease of the adsorbed amount of F127 ($400 \mu\text{mol dm}^{-3}$) at the silica-water interface was clearly detected upon increasing the concentration of salts (Figure 4).

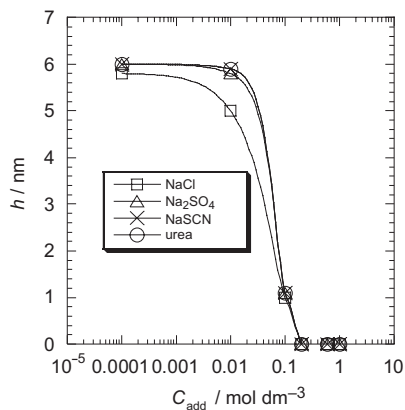

Figure 4. Influence of additives (shown in the picture) on the ellipsometric thickness h at the silica-water interface. $c_{\text{F127}} = 400 \mu\text{mol dm}^{-3}$, $\text{pH} = 6$, $t = 22 \text{ }^\circ\text{C}$.

A very similar trend was found upon increasing the concentration of urea. At first sight, this may seem puzzling, as urea is not an electrolyte. However, urea has a proton accepting carbonyl-group, by which it will adsorb from the aqueous solution on proton-donating silanol groups, so that it is also capable to displace the polymer from the interface.

At the air-water interface: an increase of the adsorbed amount with increasing electrolyte concentration is found, see Figure 5.

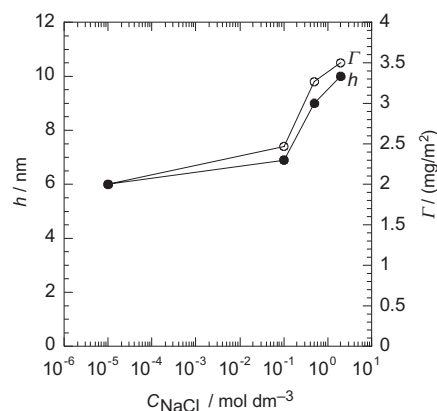

Figure 5. Influence of NaCl on ellipsometric thickness h and the adsorbed amount Γ of F127 at the air-water interface. $c_{\text{F127}} = 100 \mu\text{mol dm}^{-3}$, $\text{pH} = 6$, $t = 22 \text{ }^\circ\text{C}$.

The different behavior of F127 at the air-water and silica-water interfaces comes from different mechanisms of adsorption. At the air-water interface the triblock copolymer molecules adsorb with their hydrophobic PPO moiety towards air, and the hydrophilic PEO moiety protruding into water. With increasing NaCl concentration the solvent quality decreases and the lateral repulsion between PEO-moieties becomes smaller, whereas the anchoring affinity (χ_s) is not significantly affected. This leads to higher adsorption of polymer. We expect the same trend for an increasing concentration of Na_2SO_4 . For NaSCN and urea the effect upon solvent quality is opposite. Therefore we may expect that the adsorption of F127 at the air-water interface decreases in the presence of these additives. Alexandridis *et al.*²⁶ have measured that the surface pressure (on water) of a similar triblock copolymer, Pluronic P105 ($\text{PEO}_{37}\text{PPO}_{56}\text{PEO}_{37}$) increases in the presence of urea.

To summarize: a clear decrease in the F127 adsorption at the silica-water interface upon increasing the pH or the concentration of additive, (or both) is dominated by the cation as a displacer, whereas at the air-water interface an increase in the adsorbed amount of PEO-PPO block copolymer on raising the concentration of additives such as NaCl is most likely governed by the decreasing solvent quality.

*Effects of pH and Additives in Wetting Films:
Polymer-induced Forces and Drainage Behavior*

Polymer-induced Forces in Wetting Films. – Figure 6 shows the effect of adsorbed layers of F127 in a dilute (10^{-4} mol dm $^{-3}$) NaCl solution on the Π vs. h curves at a concentration of the polymeric surfactant below the c.m.c. ($400 \mu\text{mol dm}^{-3}$). At this concentration the silica-water interface has a saturated F127 layer, while the air-water interface has not yet reached a plateau value.¹¹

Films are stable in the range of pressure studied (0–4 kPa), indicating that there is repulsion between the interfaces within the film. In order to check the reversibility, Π vs. h isotherms are measured in two ways: first by increasing the pressure difference Δp_H down to –4 kPa, followed by bringing it back to 0 Pa (Figure 6). The arrows in Figure 6 indicate the way in which this cycle was completed. The film thicknesses obtained in the first part of the cycle are slightly higher than those obtained on the way back. However, both lead to the same thickness of ≈ 15 nm at the end of the pressure cycle (increase/decrease) at $\Pi \approx 0$: the films behave (almost) reversibly. A longer time (>15 minutes) is required to completely reach the equilibrium thickness when increasing the Π .

The steep Π vs. h dependence is characteristic for strong steric repulsion between adsorbed layers: the thickness of the film at high pressure is consistent with the sum of the thickness of the two layers adsorbed at the interfaces of the wetting films. Similar results were obtained at other F127 concentrations.¹¹

In order to compare the total thickness of the adsorbed layers of polymer $h_{\text{ads.layers}} = h_{\text{air-water}} + h_{\text{silica-water}}$ with the film thickness h_{film} , we plot the $h_{\text{ads.layers}}$ (measured by ellipsometry) versus the h_{film} measured at $\Pi = 4.5$ kPa for different concentrations of F127 (Figure 7, c_{F127} shown in $\mu\text{mol dm}^{-3}$).

The dashed line in Figure 7 represents the case $h_{\text{film}} = h_{\text{ads.layers}}$ for 10^{-4} mol dm $^{-3}$ NaCl. The two lines in Figure

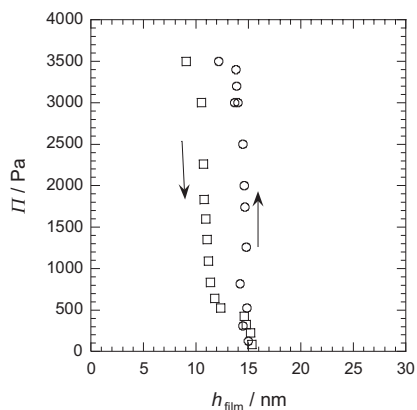

Figure 6. Reversibility of π vs. h isotherm: (O – Δp_H increases, \square – Δp_H decreases). The waiting time between each point is 15 minutes. $c_{\text{F127}} = 400 \mu\text{mol dm}^{-3}$, $\text{pH} = 6$, $c_{\text{NaCl}} = 10^{-4}$ mol dm $^{-3}$, $t = 22$ °C.

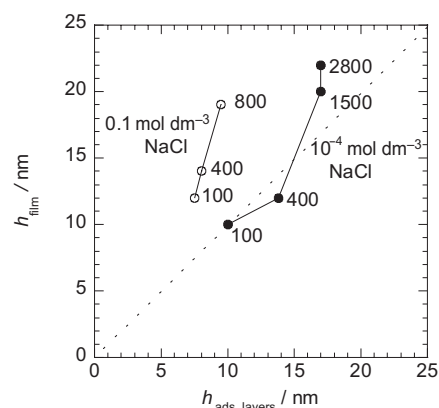

Figure 7. Equilibrium film thickness h_{film} (at $\Delta p_H = -4.5$ kPa) versus thickness of adsorbed layers $h_{\text{ads.layers}}$ at $\text{pH} = 6$, $t = 22$ °C. [F127] / $\mu\text{mol dm}^{-3}$ indicated near the points.

7 refer to low (10^{-4} mol dm $^{-3}$) and high (0.1 mol dm $^{-3}$) NaCl concentrations, respectively. In 10^{-4} mol dm $^{-3}$ NaCl the h_{film} has almost the same values as the $h_{\text{ads.layers}}$ for the studied concentrations of polymer. The slope increases somewhat with the concentration of F127, showing that h_{film} is slightly higher than the $h_{\text{ads.layers}}$ for the concentrations of F127 around the c.m.c. We should keep in mind that for films of a few nm, ellipsometrical readings are rather insensitive to the film thickness (adsorbed amounts are determined more accurately from ellipsometry).^{11,14} The value obtained for the thickness depends on the model used for the calculation: for example, the refractive index (of the adsorbed layer n_{ads} or the film n_{film} , which have different values) is a rather important parameter. Therefore, it is not surprising that the h_{film} has not exactly the same values as the $h_{\text{ads.layers}}$. In 0.1 mol dm $^{-3}$ NaCl h_{film} clearly deviates from $h_{\text{ads.layers}}$: at given $h_{\text{ads.layers}}$ the h_{film} is higher. In 0.1 mol dm $^{-3}$ NaCl the film thickness is almost twice the total thickness of the adsorbed layers. This seems unexpected: NaCl causes a shrinkage and mutual attraction of the polymer molecules so that one anticipates a lower h_{film} . Possibly, we are dealing here with a laterally inhomogeneous layer containing 'lumps' of polymer which extend further out from the surface. In our previous work we reported ellipsometric images of the film and observed that the film is highly heterogeneous in 0.1 mol dm $^{-3}$ NaCl.¹³

In Figures 8 and 9 we compare the effect of the pH (Figure 8) and 0.1 mol dm $^{-3}$ additives (Figure 9) on the interaction forces in wetting films of F127. Stable films are seen for all pH; moreover, pH has a negligible effect on h_{film} .

Most likely the steep repulsion comes from the steric effects driven by the adsorbed layers. Since the ionic strength is low, electrostatic effects might play a role as well ($\kappa^{-1} \approx 30$ nm for 10^{-4} mol dm $^{-3}$ NaCl). Besides, it is generally accepted that the potential of the clean air-water interface is negative ($\Psi_1 = -35$ mV)¹ and also the

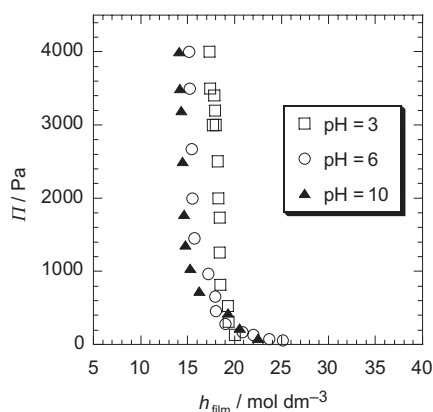

Figure 8. The effect of pH on Π vs. h isotherms at $c_{F127} = 400 \mu\text{mol dm}^{-3}$, $c_{\text{NaCl}} = 10^{-4} \text{mol dm}^{-3}$, $t = 22 \text{ }^\circ\text{C}$.

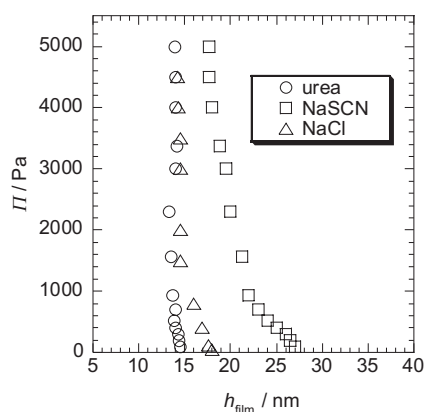

Figure 9. The effect of 0.1 mol dm^{-3} additives on Π vs. h isotherms at $c_{F127} = 400 \mu\text{mol dm}^{-3}$, $\text{pH} = 6$, $t = 22 \text{ }^\circ\text{C}$.

silica-water interface is at neutral pH negatively charged ($\Psi_1 = -30 \text{ mV}$).² If this is the case, the range of the thickness should be higher for higher pH. However, the opposite trend is observed: a higher thickness at lower pH. Apparently, the increase of the adsorbed amount at the silica-water interface (Figure 2) is more important. However, the gradual repulsion between 23 and 15 nm shows that electrostatics might play role at $\text{pH} = 10$ and below 700 Pa.

Stable films are also obtained with different additives at $\text{pH} = 6$ (Figure 9). The thickness of these films was measured after the drainage had completed. A thickness of 14–15 nm taken from the steep part of the isotherm is found for both 0.1 NaCl and urea. In $0.1 \text{ mol dm}^{-3} \text{ NaSCN}$ the h_{film} has a slightly higher value of 18 nm. It is most likely that the PEO-chains swell more in NaSCN solution.

Effects of pH and Additives on Drainage of Wetting Films. – In our previous paper¹⁴ we demonstrated that films made of F127 in the presence of a lot of NaCl (0.1 mol dm^{-3} or more) tend to drain very slowly. We reproduce one example here (Figure 10). The thickness of

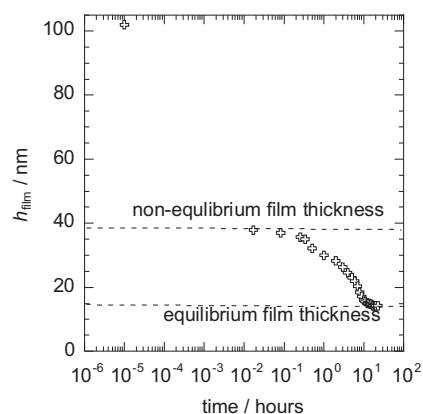

Figure 10. Film drainage in $0.1 \text{ mol dm}^{-3} \text{ NaCl}$ at a fixed $\Delta p_H = -4.5 \text{ kPa}$, $c_{F127} = 400 \mu\text{mol dm}^{-3}$, $\text{pH} = 6$, $t = 22 \text{ }^\circ\text{C}$.

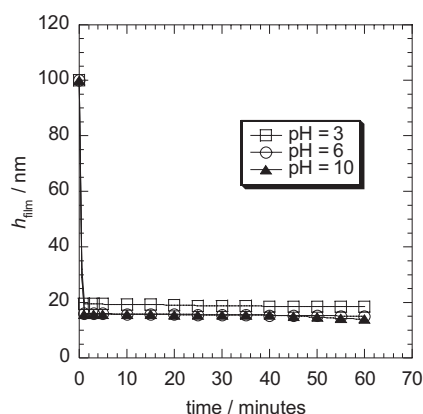

Figure 11. Influence of the pH on the film drainage at $\Delta p_H = -4.5 \text{ kPa}$, $c_{F127} = 400 \mu\text{mol dm}^{-3}$, $c_{\text{NaCl}} = 10^{-4} \text{mol dm}^{-3}$, $t = 22 \text{ }^\circ\text{C}$.

the film h is plotted *versus* time on a semilogarithmic scale.

Fast drainage is observed during the first minutes, where the thickness changes from 100 down to 40 nm. Beyond 40 nm one sees that the drainage slows down markedly and the thickness changes from 40 down to 20 nm in 15 hours. After 15 hours the thickness changes only slightly. Below we refer to films that undergo this kind of slow thinning as 'non-equilibrium films'. One of the possible explanations given for the slow drainage was an increase of the local concentration of F127 within the film, followed by gelation of F127 under the influence of NaCl.¹³ Considering that an increase of the pH (i) decreases the adsorption of F127 at the silica-water interface (Figures 2–4) and (ii) has no significant effect on the solvent quality for F127, we studied the rate of drainage of films for different pH; if our explanation makes sense, there should be no pH effect on the rate of drainage. In Figure 11 the drainage for different pH is shown.

It is clear that the slow regime is indeed not seen at any pH: all these films drain very quickly. This seems to hold generally as long as the additive concentration is

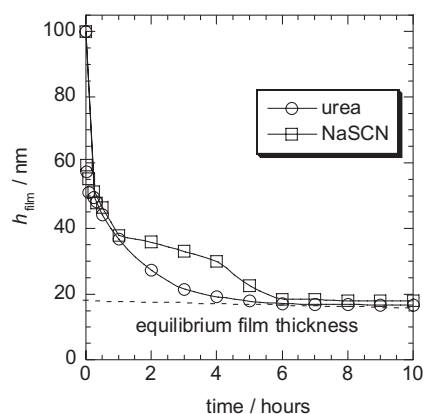

Figure 12. The influence of 0.1 mol dm^{-3} additives on film relaxation at a fixed $\Delta\rho_H = -4.5 \text{ kPa}$, $c_{\text{F127}} = 400 \text{ } \mu\text{mol dm}^{-3}$, $\text{pH} = 6$, $t = 22 \text{ } ^\circ\text{C}$.

low. However, an increase of pH from 6 to 10 in the presence of 0.1 mol dm^{-3} NaCl leads to unstable films. Moreover, the drainage slows down dramatically in 0.1 mol dm^{-3} NaCl. Supposing that the reason of the slow drainage is the solvent quality of water for F127, which depends on the temperature and the nature of additives, one wonders how the other additives affect drainage. We have seen that water becomes a better solvent for the PEO blocks if urea or NaSCN is present in the solution (salting-in effect)^{19,26} and the c.m.c. was shown to increase (Table I, see also Ref. 12). On the basis of the arguments above one expects that these additives would not slow down drainage. To check this, we have studied the effect of urea and NaSCN on the drainage of films (Figure 12).

In Figure 12 we observe, surprisingly, a similar trend as in 0.1 mol dm^{-3} NaCl (Figure 10): a slow drainage regime. The films drain a little quicker: after 5–6 hours film drainage is almost completed, whereas for NaCl this was 15 hours. Taking into account that the NaSCN displaces the gel region as well as the cloud point of F127 to a higher concentration,¹⁹ gel formation cannot explain the slow drainage of these films. Two things stand out from the data: (i) all additives have a strong retarding effect on drainage and on desorption from the solid surface; (ii) the retarding effects of NaCl and Na_2SO_4 are larger than those of NaSCN and urea.

Since all additives slow down drainage and reduce the adsorption on silica we propose that these two observations are coupled. Liquid films under external pres-

sure will usually develop a lateral thickness profile. This is because there is a hydrodynamic pressure gradient in the radial direction. The rate at which a thick film drains is therefore largely determined by the thickness at which the perimeter stabilizes: a very thin perimeter surrounding the central area of the film acts as a 'bottleneck', which retards drainage strongly. Desorption of F127 from the silica-water interface under the influence of additives might lead to weak bridging of polymers between the interfaces of film. If this happens, even if the film remains stable, liquid flow is very much impeded. The gelation effect seems to be secondary: NaCl and Na_2SO_4 enhance the drainage time by a factor of 4 or more, but the other two additives also induce a slowing down which cannot be attributed to solvency effects. Note that in 0.1 mol dm^{-3} electrolyte the electrostatic effects are screened and the deviation of films from the plane-parallel shape under the bridging attraction of polymer might indeed occur.

The shapes of curves in urea and NaSCN are different: more gradual relaxation is seen in 0.1 mol dm^{-3} urea. Probably, the electrostatic repulsion between interfaces of the film (which is not suppressed as compared with 0.1 mol dm^{-3} electrolyte) might resist the bridging attraction and therefore keep the film plane-parallel.

To summarize, the rate of drainage is controlled by the (thin) periphery of the film. We have seen that all additives reduce the adsorption at the silica surface, and that an increase in pH in the presence of these additives eventually destabilizes the films. We concluded that destabilization must be due to bridging attraction. We therefore propose that bridges are also present at lower pH and 0.1 mol dm^{-3} additive, although the bridging force is not strong enough to cause film destabilization under these conditions. If bridges are indeed present, they must have a major retarding effect on solvent flow along the midplane of the film. In a way, bridges lead to a kind of polymer network straddling the solvent film (Figure 13b).

This would strongly slow down the drainage of the film. An additional effect comes from the reduction in solvency caused by NaCl and Na_2SO_4 , which give the adsorbed layer a gel-like character, thus further retarding drainage. This latter effect is noticeable, but not as important as the bridging effect. One might object that at high pH we observed low Γ at the silica-water interface (Figure 2) and yet fast drainage of films (Figure 11). Probably, electrostatics prevents bridging in this case (by keeping the film plane-parallel).

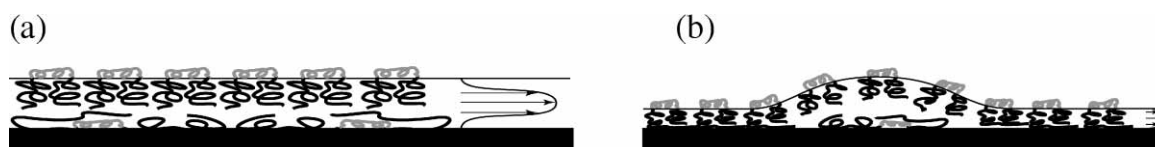

Figure 13. (a) $c_{\text{NaCl}} \leq 10^{-4} \text{ mol dm}^{-3}$: plane-parallel film, quick drainage. (b) $c_{\text{NaCl}} > 10^{-4} \text{ mol dm}^{-3}$: deflection of film from the plane-parallel shape due to bridging, slow drainage.

Wetting. – In order to assess the polymer contribution to the stability/instability of wetting films formed by aqueous solution of F127 (aforegoing section), contact angles at the silica interface were measured for different concentrations of NaCl at a given polymer concentration. The results are summarized in Table II.

TABLE II. Contact angle of aqueous solution of F127 ($100 \mu\text{mol dm}^{-3}$) at silica surface

$c_{\text{NaCl}} / \text{mol dm}^{-3}$	$\theta / ^\circ$
0	<8
10^{-4}	<8
0.1	10
1	12
2	13

Contact angles give us an idea about the interaction forces in wetting films. If the repulsive forces in wetting films are strongly dominant over the attractive ones, we expect complete wetting, while in the opposite situation we expect a finite contact angle. The slight increase of the contact angle upon raising the concentration of NaCl suggests that the bridging attraction might indeed occur.

CONCLUSIONS

The main results of this paper are that additives used in this study: (1) reduce the adsorption of F127 at the silica-water interface, (2) destabilize films at high pH, and (3) slow down drainage of films. We think that reduction of adsorption and retardation of drainage is coupled. We propose that bridges, which occur under the influence of additives, impede liquid flow (Figure 13b). Moreover, we suggest that destabilization comes from the attractive contribution, which most likely is also driven by polymer bridging. Electrostatic repulsion might give extra stabilizing effect in films at pH = 10 and low salt concentration.

Acknowledgement. – O. V. Eliseeva acknowledges Professor J. Lyklema for many helpful discussions.

REFERENCES

1. D. Exerowa and P. Kruglyakov, *Foam and Foam Films*, Elsevier Science B.V., Amsterdam, 1998.
2. K. Stöckelhuber and A. Werner, *Eur. Phys. J. E*, **12**, (2003) 431–435.
3. J. Lyklema, *Fundamentals of Interface and Colloid Science, I: Fundamentals*, Academic Press Ltd., London, 1991.
4. N. V. Churaev, *Colloid J.* **65** (2002) 263–274.
5. N. V. Churaev, *Colloid J.* **62** (2000) 517–525.
6. D. H. Napper, *Polymeric stabilization of colloidal dispersions*, Academic Press Ltd., London, 1983.
7. G. J. Fleer, M. A. Cohen Stuart, J. M. H. M. Scheutjens, T. Cosgrove, and B. Vincent, *Polymers at interfaces*, Chapman & Hall, London, 1993.
8. B. Diakova, C. Filiatre, D. Platikanov, A. Foissy and M. Kaisheva, *Adv. Colloid Interface Sci.* **96** (2002) 193–211.
9. B. Diakova, M. Kaisheva, and D. Platikanov, *Colloids Surf.* **190** (2001) 61–70.
10. B. Diakova, D. Platikanov, R. Atanassov, and M. Kaisheva, *Adv. Colloid Interface Sci.* **104** (2003) 25–36.
11. O. V. Eliseeva, N. A. M. Besseling, L. K. Koopal, and M. A. Cohen Stuart, *Langmuir* **21** (2005) 4954–4963.
12. N. E. Esipova, S. V. Itskov, and N. V. Churaev, *Colloid J.* **64** (2002) 699–705.
13. O. V. Eliseeva, R. G. Fokkink, N. A. M. Besseling, L. K. Koopal, and M. A. Cohen Stuart, *J. Colloid Interface Sci.* **301** (2006) 210–216.
14. M. A. Cohen Stuart, G. J. Fleer, and H. M. Scheutjens, *J. Colloid Interfaces Sci.* **97** (1984) 515–535.
15. K. J. Mysels and M. N. Jones, *Discuss. Faraday Soc.* **42** (1966) 42.
16. V. A. Shishin, Z. M. Zorin, and N. V. Churaev, *Kolloidnyi Zhurnal (English transl.)* **39** (1977) 351.
17. B. V. Derjaguin, Z. M. Zorin, N. V. Churaev, and V. A. Shishin, in: J. F. Padday (Ed.), *Wetting, Spreading and Adhesion*. Academic Press, London, 1977.
18. H. G. Tompkins, *A User's Guide to Ellipsometry*, Academic Press, Inc., San Diego, 1993.
19. M. Malmsten and B. Lindman, *Macromolecules* **25** (1992) 5440–5445.
20. G. Wanka, H. Hoffman and W. Ulbricht, *Macromolecules* **27** (1994) 4145–4159.
21. P. Alexandridis and J. F. Holzwarth, *Langmuir* **13** (1997) 6074–6082.
22. A. Nelson and T. Cosgrove, *Langmuir* **21** (2005) 9176–9182.
23. K. D. Collins and M. W. Washabaugh, *Q. Rev. Biophys.* **18** (1985) 323–422.
24. A. Kabalnov, U. Olsson, and H. Wennerström, *J. Phys. Chem.* **99** (1995) 6220–6230.
25. E. Florin, R. Kjellander, and J. C. Erikson, *J. Chem. Soc., Faraday Trans. 1* **80** (1984) 2889–2910.
26. P. Alexandridis, V. Athanassiou, and T. A. Hatton, *Langmuir* **11** (1995) 2442–2450.
27. T. van den Boomgaard and J. Lyklema, *Langmuir* **5** (1989) 245–249.
28. J. Rubio and J. A. Kitchener, *J. Colloid Interface Sci.* **57** (1976) 132–142.
29. M. Malmsten, P. Linse and T. Cosgrove, *Macromolecules* **25** (1992) 2474–2481.
30. T. van den Boomgaard, T. F. Tadros, and J. Lyklema, *J. Colloid Interfaces Sci.* **116** (1986) 8–16.

SAŽETAK

Utjecaj pH i aditiva na kvašene filmove stabilizirane triblok kopolimerom

O. V. Eliseeva, N. A. M. Besseling, L. K. Koopal i M. A. Cohen Stuart

Ispitivan je učinak pH i aditiva (NaCl, Na₂SO₄, NaSCN i uree) na adsorpciju triblok kopolimera ABA (F127) s polietilen oksidom kao blokom A i polipropilen oksidom kao blokom B na površinu kvašenih filmova. Učinak na sušenje filma i na interakcije sile u tim filmovima istražen je pomoću elipsometrije i TFB (Thin Film Balance) tehnike. Utjecaj navedenih aditiva na micelizaciju praćen je metodom statičkog raspršenja svjetlosti. Uočeno je, da svi navedeni aditivi smanjuju adsorpciju na silicijev oksid i usporavaju sušenje filma. Osim toga, pri visokim pH vrijednostima (≈ 10) uz 0,1 mol dm⁻³ NaCl dolazi do destabilizacije filma. Smanjenje količine adsorbiranog kopolimera je korelirano s dramatičnim usporavanjem procesa sušenja filma. Polagano sušenje, kao i destabilizacija filma pripisani su privlačenju gusto prekrivene međupovršine zrak-voda i slabo prekrivene međupovršine silicijev oksid-voda.