

nn 0201

no 744

C

Wind-profile measurements above a maize crop

T. Reitsma



NN08201.744

T. Reitsma

Wind-profile measurements above a maize crop

Proefschrift

ter verkrijging van de graad van
doctor in de landbouwetenschappen,
op gezag van de rector magnificus,
dr. H.C. van der Plas,
hoogleraar in de organische scheikunde,
in het openbaar te verdedigen
op donderdag 7 december 1978
des namiddags te vier uur in de aula
van de Landbouwhogeschool te Wageningen



Centre for Agricultural Publishing and Documentation
Wageningen - 1978

Abstract

Reitsma, T. (1978) Wind-profile measurements above a maize crop. Agric. Res. Rep. (Versl. landbouwk. Onderz.) 882, ISBN 90 220 0684 0, (ix) + 103 p., 52 figs, 19 tables, 92 refs, 4 appendices, Eng. and Dutch summaries.

Also: Doctoral thesis, Wageningen.

An experiment of wind-profile measurements above a maize crop was described. First the mean ratio between the height of the adapted layer and the fetch was deduced from profile measurements at several positions in the field. The height-to-fetch ratio amounted to 1/64. Because of too small a fetch, the vertical transport of momentum between the maize crop and the atmosphere could not be estimated accurately enough from the wind-profile measurements only. The parameters of the assumed logarithmic wind profile, the zero-plane displacement and the roughness length, could only be estimated from a comparison of wind-profile measurements with simultaneous eddy-correlation measurements. In the present experiment, the zero-plane displacement d and the roughness length z_0 could be expressed in the height h of the full-grown crop as $d = 0.5 h$ and $z_0 = 0.11 h$, respectively. The application of a common empirical relationship from the literature (e.g. $d = 0.6 h$) led to considerable systematic errors of the estimated friction velocity above maize.

Keywords: micrometeorology, logarithmic wind profile, wind-profile measurements, ratio height of the adapted layer-to-fetch.

This thesis will also be published as Agricultural Research Reports 882.

© Centre for Agricultural Publishing and Documentation, Wageningen, 1978.

No part of this book may be reproduced or published in any form, by print, photoprint, microfilm or any other means without written permission from the publishers.

Stellingen

1. Als gevolg van onvoldoende aanstrijk lengte van de meeste (bouwland)percelen in Nederland is toepassing van de profielmethode ter bepaling van de turbulente uitwisseling van deze percelen niet goed mogelijk.

Dit proefschrift, hoofdstuk 6.

2. Berekening van de nulvlaksverplaatsing en de ruwheidslengte uit windprofielmetingen met behulp van regressieanalyse volgens de kleinste-kwadratenmethode zoals gepubliceerd door Robinson en Covey, leidt ook met zeer nauwkeurige windsnelheidsmetingen dikwijls tot fysisch onaanvaardbare waarden.

S.M. Robinson, 1962. J. Atmos. Sci. 19: 189-190.

W. Covey, 1963. Prod. Res. Rep. No 72 Agric. Res. Serv. U.S. Dep. Agric.: 28-33.

3. Toepassing van een eenvoudige empirische relatie tussen nulvlaksverplaatsing en gewas-hoogte zoals door verschillende onderzoekers wordt aanbevolen voor het schatten van de verticale uitwisseling tussen gewas en atmosfeer uit windprofielmetingen, kan leiden tot onaanvaardbaar grote systematische fouten bij de bepaling van turbulente uitwisselings-coëfficiënten.

G. Stanhill, 1969. J. appl. Meteorol. 8: 509-513.

J.L. Monteith, 1973. Principles of environmental physics. E. Arnold, London, 241 p.

4. Met de analysemethode van Webb is de bepaling van de nulvlaksverplaatsing ook onder niet-neutrale omstandigheden in principe mogelijk. Echter moeten dan de windsnelheidsmetingen en de aanstrijk lengte aan wel zéér hoge eisen voldoen.

E.K. Webb, 1970. Q. J. R. meteorol. Soc. 96: 67-90.

5. De door verschillende onderzoekers gegeven (soms vrij gedetailleerde) afhankelijkheid van de gewasparameters van de windsnelheid is nauwelijks overtuigend.

D.S. Munro & T.R. Oke, 1973. Agric. Meteorol. 11: 223-228.

J. Stoller & E.R. Lemon, 1963. Prod. Res. Rep. No 72 Agric. Res. Serv. U.S. Dep. Agric.: 34-46.

6. De overschatting van de windsnelheid gemeten met een cup-anemometer leidt bij de profielmethode alleen tot een overschatting van de wrijvingsnelheid. Het verdient aanbeveling voor deze overschatting een eerste-ordecorrectie toe te passen, zoals bijvoorbeeld door Businger et al. wordt gevonden.

J.A. Businger et al., 1971. J. Atmos. Sci. 28: 181-189.

7. Uit de grote spreiding in de gevonden waarden van de nulvlaksverplaatsing van een bepaald gewas mag niet worden geconcludeerd dat aan deze parameter fysisch geen betekenis kan worden gehecht.

W.D. Sellers, 1965. Physical Climatology. Chicago University Press.
T.E.A. van Hylckama, 1970. Agric. Meteorol. 7: 217-233.

8. Men kan aannemelijk maken dat de gegeneraliseerde windfunctie in Penmans verdampingsformule zoals door Doorenbos & Pruitt voorgesteld, ook reeds correcties voor een onstabiele atmosfeer bevat.

J. Doorenbos & W.O. Pruitt, 1977. FAO Irrigation and Drainage paper no 24 (rev.)
144 p.
A.S. Thom & H.R. Oliver, 1977. Q. J. R. meteorol. Soc. 103: 345-357.

9. De mogelijkheid warmtebeelden (remote sensing) ondubbelzinnig te interpreteren wordt dikwijls overschat.

10. Bij toepassing van de theorie van Philip ter bepaling van de correctiefactor voor grondfluxplaten moet men rekening houden met aanzienlijke afwijkingen.

J.R. Philip, 1961. J. geophys. Res. 66: 571-575.

11. De term slaapstad suggereert dat deze stad slechts dient om er de nacht door te brengen. Voor minstens de helft van de bevolking gaat dit niet op.

12. De zegswijze "Het weer en de vrouwen, ze zijn niet te vertrouwen" getuigt vooralsnog van gebrek aan kennis.

J.H. Pelleboer, 1976. Volkswaerkunde. Boekencentrum b.v., Den Haag.

Woord vooraf

Een proefschrift wordt in het algemeen geschreven door één auteur. Het uitvoeren van de proef is echter alleen mogelijk door inzet en medewerking van velen. Bij dit onderzoek is dat zeker het geval geweest. Velen hebben direct of indirect meegewerkt aan het tot stand komen ervan. Ik wil een ieder die een steentje, groot of klein, heeft bijgedragen hiervoor bedanken. Mijn dank gaat in het bijzonder uit naar

- professor J. Schenk, mijn promotor, voor zijn waardevolle bijdrage aan dit proefschrift;
- Frits Bottemanne, mijn begeleider, voor de dagelijkse begeleiding en de vele suggesties;
- Bas Lammers voor zijn hulp bij het uitvoeren van het onderzoek en het uitwerken van de gegevens;
- Rudy Altmann, Cees van Asselt, Johan Birnie, Henny Boshoven, Gerard Bot, Wim Driessen, Willy Hillen, Anton Jansen, Peter Jansen, Teun Jansen, Jimmy Lengkeek, Wim Vaags, Bart Verhaaf, Dick Welgraven en Joop van Zeeland voor het verzorgen van meetapparatuur, het verrichten van metingen en het verwerken daarvan;
- Jo van den Brink voor het maken van foto's;
- Paul van Espelo voor het vele tekenwerk;
- Corry Pitlo voor het contact met het thuisfront tijdens de meetdagen en voor een gedeelte van het typewerk;
- de bedrijfsingenieur van de Ir. A.P. Minderhoudhoeve, dr.ir. E.G. Kloosterman, en zijn medewerkers voor de jarenlange gastvrijheid en plezierige samenwerking;
- de vakgroep Natuur- en Weerkunde en de Landbouwhogeschool die dit promotie-onderzoek mogelijk hebben gemaakt;
- het Rekencentrum voor het verwerken van de honderden meters ponsband;
- de afdeling Tekstverwerking voor het verzorgen van het manuscript;
- de medewerkers van 'Pudoc' die voor revisie van het Engels, redactie en uitgave van het manuscript zorg hebben gedragen.

Curriculum vitae

De schrijfster van dit proefschrift werd geboren op 8 oktober 1946 te Ureterp. Zij behaalde in 1966 het eindexamen Gymnasium β aan het Drachtster Lyceum te Drachten. In hetzelfde jaar begon zij haar studie aan de Landbouwhogeschool te Wageningen, alwaar zij in 1973 afstudeerde (hoofdvak cultuurtechniek, bijvakken hydraulica en afvoerhydrologie, meteorologie en wiskunde). Van 1 maart tot 1 september 1973 was zij als wetenschappelijk ambtenaar werkzaam op de Afdeling Hydraulica en Afvoerhydrologie van de Landbouwhogeschool, daarna tot 15 januari 1974 op het International Institute for Land Reclamation and Improvement eveneens te Wageningen. Per 15 januari trad zij als wetenschappelijk assistente in dienst van de Afdeling Natuur- en Weerkunde van de Landbouwhogeschool, waar zij tot 1 januari 1978 gelegenheid kreeg zich te wijden aan het onderzoek dat in dit proefschrift is beschreven.

Contents

List of symbols most frequently used

1	<i>Introduction</i>	1
2	<i>Logarithmic wind profile</i>	4
2.1	Surface boundary layer	4
2.1.1	Neutral atmosphere	5
2.1.2	Non-neutral atmosphere	8
2.2	Profile method	9
2.2.1	Graphical method	10
2.2.2	Regression analysis by the method of least squares	11
2.2.3	Empirical relationships of crop parameters	12
2.3	Comparison with eddy-correlation method	13
2.3.1	Eddy-correlation method	13
2.3.2	Drag coefficient	14
3	<i>Conditions of measurement</i>	15
3.1	Appropriate run duration	15
3.2	Fetch	15
3.3	Mast effects	19
3.4	Number and minimum difference in height of the sensors	20
4	<i>The experiments</i>	21
4.1	Weather during measurements	22
4.2	Experimental field and crop	23
4.2.1	Measuring plot	25
4.2.2	Measuring arrangement and equipment	26
4.3	Instruments and recording	33
4.3.1	Instruments used for the wind-profile method	33
4.3.1.1	Calibration of the cup-anemometers	35
4.3.1.2	Overestimation of wind velocity	37
4.3.2	Instruments used for the energy balance and eddy-correlation method	37
5	<i>Fetch and height of measurement</i>	39
5.1	Estimate of the actual fetch	39
5.2	Influence of fetch on the wind profile	40
5.3	Dependence of the height of the adapted layer on wind velocity	42

5.4	Estimate of the height-to-fetch ratio	44
5.5	Measuring layer	49
6	<i>Zero-plane displacement and roughness length</i>	51
6.1	Estimation of zero-plane displacement and roughness length	51
6.2	Data selection	51
6.2.1	The graphical method	51
6.2.2	Regression analysis by the method of least squares	52
6.2.3	Modified method of least squares	53
6.2.4	Estimate of d and z_0 from simultaneous wind-profile measurements and eddy-correlation measurements	54
6.3	Dependence of d and z_0 on wind velocity and on atmospheric conditions	56
6.4	Mean zero-plane displacement and roughness length	64
6.5	Effect of overestimation of wind velocity	70
6.6	An empirical relationship of crop parameters	72
7	<i>Measurements above grass</i>	73
7.1	Wind profile above grass	73
7.2	Friction velocity and roughness length	74
7.3	Comparison of results from measurements above grass and maize	78
8	<i>Final discussion and conclusions</i>	83
8.1	Thickness of the adapted layer	83
8.2	Estimate of d , z_0 and u_* from wind-profile measurements above maize	83
8.3	Wind-profile and eddy-correlation measurements	84
8.4	Homogeneity	84
8.5	The ratio d/h	85
8.6	A fluctuating zero-plane displacement	86
8.7	Results from measurements above grass and maize	86
	<i>Summary</i>	88
	<i>Samenvatting</i>	90
	<i>References</i>	92
	<i>Appendices</i>	96
	Appendix 1	96
	Appendix 2	98
	Appendix 3	100
	Appendix 4	101

List of symbols most frequently used

			first used in Section
c	$= C_d^{\frac{1}{2}}$	-	2.3.2
C_d	$= (\overline{u'_x}/\overline{u})^2 =$ drag coefficient	-	2.3.2
c_e	$= C_d^{\frac{1}{2}}$ from eddy-correlation measurements	-	6.2.4
c_p	$= C_d^{\frac{1}{2}}$ from wind-profile measurements	-	6.2.4
c_p	= specific heat capacity of air at constant pressure	J/(kg.K)	2.1.1
d	= zero-plane displacement	m	2.1.1
g	= acceleration due to gravity	m/s ²	2.1.2
h	= crop height	m	2.2.3
H	= vertical transport of sensible heat	J/(m ² .s)	2.1.1
$h(x)$	= height of internal boundary layer	m	3.2
k	= von Kármán constant = 0.4	-	2.1.1
K_H	= turbulent exchange coefficient for heat	m ² /s	2.1.1
K_M	= turbulent exchange coefficient for momentum	m ² /s	2.1.1
l	= mixing length	m	2.1.1
L	= Monin-Obukhov length	m	2.1.2
Ri	= Richardson number	-	2.1.2
T	= absolute temperature of air	K	2.1.2
T'	= turbulent fluctuation of temperature	K	2.3.1
u	= instantaneous horizontal wind velocity	m/s	2.1
\overline{u}	= mean horizontal wind velocity	m/s	2.1
u'	= turbulent fluctuation of horizontal wind velocity	m/s	2.1
u_*	$= (\tau/\rho)^{\frac{1}{2}} =$ friction velocity	m/s	2.1.1
v	= instantaneous lateral wind velocity	m/s	2.1
\overline{v}	= mean lateral wind velocity	m/s	2.1
v'	= turbulent fluctuation of lateral wind velocity	m/s	2.1
V	= total wind velocity	m/s	2.1
V_h	= total horizontal wind vector	m/s	2.1
w	= instantaneous vertical wind velocity	m/s	2.1
\overline{w}	= mean vertical wind velocity	m/s	2.1
w'	= turbulent fluctuation of vertical wind velocity	m/s	2.1
x	= horizontal distance	m	2.1
z	= height above ground level	m	2.1
z/L	= stability parameter	-	2.1.2
z_0	= roughness length	m	2.1.1
$\delta(x)$	= thickness of adapted layer	m	3.2

$\delta'(x)$	= height of adapted layer with reference to ground level	m	5.4
θ	= potential temperature	K	2.1.1
ρ	= mass density of air at constant pressure	kg/m ³	2.1.1
τ	= vertical transport of momentum, shear stress	N/m ²	2.1.1
$\phi_u(z/L)$	= stability function	-	2.1.2

1 Introduction

The present research originated from an earlier project on the microclimate within a maize crop, that was performed in 1972 and 1973 by the Department of Physics and Meteorology of the Agricultural University (Stigter, 1974). In that experiment, an estimate was needed of the vertical transport of momentum, heat and water vapour within and above the crop.

These vertical fluxes above a crop can also be considered as the output of the microclimate within the crop. As a result of that viewpoint, measurements of vertical transport may act as experimental checks on simulation models for crop growth (Lemon et al., 1971; Goudriaan, 1977). Moreover knowledge of these transport phenomena can be used to estimate the evapo(transpi)ration of a crop (Mukammal et al., 1966; Szeicz et al., 1969) or of bare soil. Photosynthesis too within a crop is connected with vertical transport of mass.

In agricultural research, the vertical transport of momentum, heat and water vapour are often estimated by an aerodynamic method (Penman & Long, 1960; Wright & Lemon, 1966; Oliver, 1971; Nkemdirim, 1974; McCaughey & Davies, 1975), that is mostly indicated as the profile method. Often this profile method is combined with other methods like energy balance (Mukammal et al., 1966; Stanhill & Fuchs, 1968; Szeicz & Long, 1969; Tajchman, 1973; Thom et al., 1975). For the profile method, quantities like wind velocity, temperature and humidity have to be measured at different heights for a certain period. Then vertical transport of momentum, heat and water vapour can be estimated from the gradients of these quantities. Usually for the calculation of these transports, the conventional logarithmic model (including a simple K theory) is adopted.

More recently the eddy-correlation method was developed, that is based on a physically more justified model (Munn, 1966; Rose, 1966) and is therefore more attractive. By this method, vertical transports are directly estimated by correlation of the instantaneous fluctuations in the relevant quantities with the instantaneous fluctuations in wind velocity. The development of fast-response sensors, suitable to record these fluctuations and advanced electronics for on-line data processing should allow application of this method. However as yet, many problems about the eddy-correlation method are not satisfactorily solved and application is rather troublesome.

For the profile method, *averaged* values of wind velocity, temperature and humidity have to be measured. One can then use simpler and cheaper sensors. For agricultural research and for routine measurements, such equipment suitable for measurements of these mean quantities will be more readily available and, therefore, in general the profile method will be preferred.

Nevertheless, application in the near future of the eddy-correlation method was to be expected for routine measurements, while the profile method remains competitive. If

2 Logarithmic wind profile

2.1 SURFACE BOUNDARY LAYER

In discussing the details of air flow, it is convenient to consider the atmosphere to be divided into a number of horizontal layers. In his well known textbook Sutton (1953) presents the following picture.

Extending to about a kilometre above the surface the friction layer or planetary boundary layer can be distinguished, a transition zone from the disturbed air flow just near the surface to the frictionless flow in the free atmosphere, where the actual wind speed can be usefully approximated by the geostrophic wind. Difficult dynamic problems are those encountered in the surface boundary layer extending to no more than 100 m above the surface. Here for problems involving wind near the ground it is usually possible to treat the pressure gradient as a constant driving force and to ignore entirely the effects of the rotation of the earth (Coriolis force).

In this way, typical micrometeorological scale lengths can be defined, e.g. a horizontal distance up to 1 km and a height of 10 or 20 m above the surface. The most important phenomena in this area are friction and the influence of mass density gradients. The earth's surface causes the surface wind to be fully turbulent. Only very near to the surface, an interfacial sublayer can be distinguished, in which also molecular transport phenomena may be important. The air flow in this latter layer may be laminar or turbulent dependent on the nature of the surface.

In micrometeorology, we are in particular interested in air movements within the lower part of the surface boundary layer (Fig. 1). In this lower zone the buoyancy forces, resulting from the density gradients, are mostly small in comparison with frictional forces. This means that this dynamic sublayer can be considered to be under atmospherically neutral or near-neutral conditions. The near-neutral situation prevails when the vertical heat flux is small. When the heat flux is upwards, the atmospheric conditions are unstable. A downward heat flux corresponds with inversion, or stable conditions.

The turbulent air movement near the surface occurs as a fluctuating surface wind velocity. Conventionally the total wind velocity V is represented within a right-handed orthogonal coordinate system, as in Figure 2. The x axis is chosen parallel to the mean (horizontal) wind velocity \bar{u} . The instantaneous velocity components can be read as

$$u = \bar{u} + u' \tag{1a}$$

$$v = \bar{v} + v' \tag{1b}$$

$$w = \bar{w} + w' \tag{1c}$$

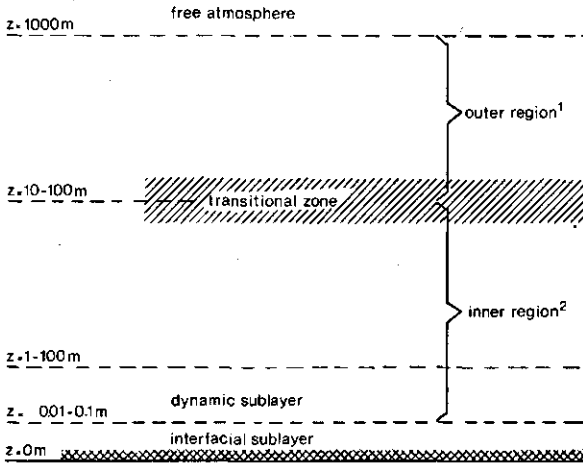

Fig. 1. Planetary boundary layer 0 - 1000 m. 1 = outer region or defect sublayer; 2 = inner region or surface boundary layer.

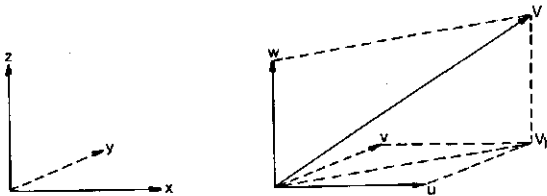

Fig. 2. The coordinate system.

With this choice of direction of the x axis, the mean lateral and vertical velocities are zero. Thus

$$\bar{v} = \bar{w} = 0$$

In this convention for the fluctuation, the following holds

$$\bar{u}' = \bar{v}' = \bar{w}' = 0$$

2.1.1 Neutral atmosphere

In general, the mean wind velocity in the dynamic sublayer can be expressed as a function of the height by the logarithmic law:

$$\bar{u} = (u_* / k) \ln (z / z_0) \quad (2)$$

where u_* is friction velocity, k von Kármán constant, z_0 roughness length, z height above ground level and \bar{u} mean wind velocity at height z . For theoretical details about the

logarithmic wind profile, see well known handbooks like Sutton (1953), Lumley & Panofsky (1964) and Tennekes & Lumley (1972).

To arrive at Equation 2 a number of assumptions must be made. The main ones are mentioned here:

1. The mean flow is one-dimensional, steady and horizontal.
2. The density of the air is supposed to be constant and the horizontal pressure gradient is negligible.
3. The height above the surface should be large in comparison with the characteristic roughness length of the surface obstacles.

With these assumptions, the equations of motion show that the shear stress, or the transport of momentum, is independent of the height in the lowest tens of metres of the surface layer.

Analogous to the molecular transport coefficient (kinematic viscosity, ν) within a laminar boundary layer, the turbulent exchange coefficient K_M is also defined by a linear proportionality of shear stress τ with velocity gradient.

$$\tau = \rho K_M \frac{d\bar{u}}{dz} \quad (3)$$

where ρ is mass density of air.

Apart from the vertical transport of momentum in a turbulent boundary layer, transport of heat H is described in the same way as molecular diffusion in a laminar boundary layer.

$$H = -\rho c_p K_H \frac{d\bar{\theta}}{dz} \quad (4)$$

where c_p is specific heat capacity at constant pressure and θ potential temperature. The turbulent exchange coefficient for heat K_H is now analogous to the molecular diffusivity of heat $a = \lambda/\rho c_p$ with the thermal conductivity λ .

According to the theory of turbulence, the vertical transport of momentum can be considered as proportional to the correlation of the horizontal and vertical wind velocity fluctuations:

$$\tau = -\rho \overline{u'w'} \quad (5)$$

The exchange coefficient K_M can now be written as

$$K_M = -\overline{u'w'}/(d\bar{u}/dz) \quad (6)$$

Introducing the mixing length theory of Prandtl (e.g. Sutton, 1953) the transport of momentum can be described by

$$\tau = \rho l^2 \left(\frac{d\bar{u}}{dz} \right) \left| \frac{d\bar{u}}{dz} \right| \quad (7)$$

where l is the mixing length and

$$l/z = k \quad (8)$$

where k is the von Kármán constant. Using Equations 3 and 7, it follows that

$$K_M = l^2 |d\bar{u}/dz| \quad (9)$$

By definition,

$$u_* \equiv (\tau/\rho)^{1/2} \quad (10)$$

and with Equations 7 and 8, the wind shear can be written as

$$d\bar{u}/dz = u_*/(kz) \quad (11)$$

and with Equations 8 and 9

$$K_M = ku_*z \quad (12)$$

By integration of Equation 11

$$\bar{u} = (u_*/k) \ln (z/z_0) \quad (2)$$

Roughness length z_0 is introduced as a constant of integration. This parameter relates to the nature of the surface and needs to be obtained from experimental data. According to Equation 2 the mean wind velocity is equal to zero at a height equal to the roughness length.

In general for a flow above tall vegetation, Equation 2 turns to

$$\bar{u} = (u_*/k) \ln ((z - d)/z_0) \quad (13)$$

The length d reflects the zero-plane displacement. This parameter is introduced to account for the fact that \bar{u} is not exactly proportional to $\ln z$. Mathematically it represents a vertical displacement of the coordinate system.

For mathematical reasons, Equation 2 is sometimes expressed as

$$\bar{u} = (u_*/k) \ln ((z + z_0)/z_0) \quad (14)$$

and consequently Equation 13 as

$$\bar{u} = (u_*/k) \ln ((z + z_0 - d)/z_0) \quad (15)$$

This means that the logarithmic model implies a wind velocity of zero at a height of

0 or d , respectively. The difference between the zero-plane displacement and the roughness length is sometimes called the effective height of vegetation (Tanner, 1963):

$$D = d - z_0 \quad (16)$$

When $z \gg z_0$ the latter can be neglected with respect to z and Equations 14 and 15 are similar to Equations 2 and 13, respectively.

These equations apply only for neutral or near-neutral conditions and are valid only in the dynamic sublayer.

2.1.2 Non-neutral atmosphere

For non-neutral atmospheric conditions, the relationships of Section 2.1.1 are adapted by introduction of stability corrections. The wind shear (Eq. 11) can be adjusted to a non-adiabatic atmosphere as follows:

$$d\bar{u}/dz = (u_* / (kz)) \cdot \phi_u(z/L) \quad (17)$$

$\phi_u(z/L)$ is a function of the height z and a stability length L first introduced by Monin & Obukhov:

$$L = -u_*^3 / (k \frac{g}{T} H / (\rho \sigma_p)) \quad (18)$$

where T absolute temperature of air and H vertical transport of heat. Numerous functions have been proposed for $\phi_u(z/L)$. One of the earliest forms was given by Monin & Obukhov (1954):

$$\phi_u(z/L) = 1 + \alpha_1(z/L) + \alpha_2(z/L)^2 + \alpha_3(z/L)^3 + \dots \quad (19)$$

For slightly unstable conditions, they neglected higher-order terms:

$$d\bar{u}/dz = (u_* / (kz)) \cdot (1 + \alpha z/L) \quad (20)$$

By integrating Equation 20,

$$\bar{u} = (u_* / k) \cdot (\ln \frac{z}{z_0} + \alpha \frac{z}{L}) \quad z \gg z_0 \quad (21)$$

After introduction of d , Equation 21 becomes

$$\bar{u} = (u_* / k) \cdot (\ln \frac{z-d}{z_0} + \alpha \frac{z-d}{L}) \quad (z-d) \gg z_0 \quad (22)$$

These equations are called the 'logarithmic linear wind profile', to be distinguished from the 'logarithmic wind profile' of Section 2.1.1. The value of the parameter α should be independent of the degree of instability and needs to be determined from experiments. How-

ever the data in the literature differ considerably. For instance under unstable conditions, Monin & Obukhov found $\alpha = 0.6$ but Webb (1970) $\alpha = 4.5$. Under stable conditions Webb found $\alpha = 5.2$, Businger et al. (1971) $\alpha = 4.7$, but McVehil (1964) $\alpha = 7$.

An alternative stability parameter is the Richardson number defined as

$$Ri = (g/T) \cdot (d\bar{\theta}/dz) / (d\bar{u}/dz)^2 \quad (23)$$

where g is acceleration due to gravity. For neutral conditions, Ri approaches zero. The sign of Ri obviously depends on the sign of the temperature gradient, so Ri is positive in a stable atmosphere and negative in an unstable atmosphere. The parameter depends on height. From Equations 3, 4, 10, 17 and 18

$$Ri = (K_M/K_H) \cdot (z/L) \cdot (1/\phi_u(z/L)) \quad (24)$$

As mentioned before, for near-neutral conditions, $\phi_u(z/L)$ approaches 1.

According to the Monin-Obukhov similarity theory, the exchange coefficients K_H and K_M should be equal. This leads as a first approximation to

$$Ri \approx z/L \quad (25)$$

Recent investigations, however, suggest that K_H and K_M are not equal. This inequality can also be represented by taking different von Kármán constants for both heat and momentum flux in a turbulent boundary layer. According to Businger et al. (1971) in a neutral atmosphere K_H/K_M should be about 1.35. This leads to a slightly different relation between Ri and L , but it does not influence the proportionality of Ri with height z .

Other models describing the transport of momentum in both a neutral and a non-neutral turbulent boundary layer have been developed (De Boer-Waanders, 1972). As yet, experimental accuracy does not permit definite conclusions about differences between the models, in particular under near-neutral conditions (e.g. Bernstein, 1966; Charnock, 1967). Thus for simplicity, as conventional, only the logarithmic and logarithmic linear model are applied. For the same reason no particular attention is given in this chapter on more precise theoretical considerations and on the physical interpretation of Ri and L .

2.2 PROFILE METHOD

Equation 13 (Sect. 2.1.1) implies that for neutral conditions the logarithmic wind profile holds for any height z_i

$$\bar{u}_i = (u_* / k) \ln ((z_i - d) / z_0) \quad (26)$$

By measurements of \bar{u}_i at at least three heights z_i the Equation 26 leads to three or more independent equations that may be solved in principle, thus determining d , z_0 and u_* . For low vegetation or bare soil, the zero-plane displacement is mostly negligible. If so, the estimation of u_* and z_0 is rather easy. For taller vegetation, it is difficult to adjust

a reproducible value of d and to solve Equation 26 uniquely.

In the next sections, two methods are discussed of estimating d and z_0 , and thus u_* , from measurements. These methods should only be applied under almost ideal conditions, e.g. a well developed dynamic boundary layer. In practice, however, these ideal conditions are rarely met and so it is difficult to determine d and z_0 , and an alternative estimate of these parameters is necessary. To that end a simple empirical approach will be discussed.

2.2.1 Graphical method

According to Equation 26, there is a linear relation between the mean wind velocity \bar{u}_z and the logarithm of the height ($z_z - d$). The linear relation only holds when a proper value of d is used. By plotting \bar{u}_z against $\ln(z_z - d)$ for different values of d and by selecting the best linear curve, the best fitting value of d can be deduced (Fig. 3). Subsequently the roughness length z_0 follows from extrapolation of this straight line to $\bar{u}_z = 0$. From the slope of the straight line, at last, u_* can be calculated. The graphical method has been applied to profile measurements of, among others, Udagawa (1966) above barley, Stanhill & Fuchs (1968) above a cotton crop, Guyot (1969) above a maize crop, Oliver (1971) above a forest, Kalma & Stanhill (1972) above an orange orchard, Tajchman (1973) and Biscoe et al. (1975) above a pine forest.

A big advantage of this method is that one can evaluate the measured data at once, without preliminary elaboration. From a graph, like Figure 3, one can immediately get an

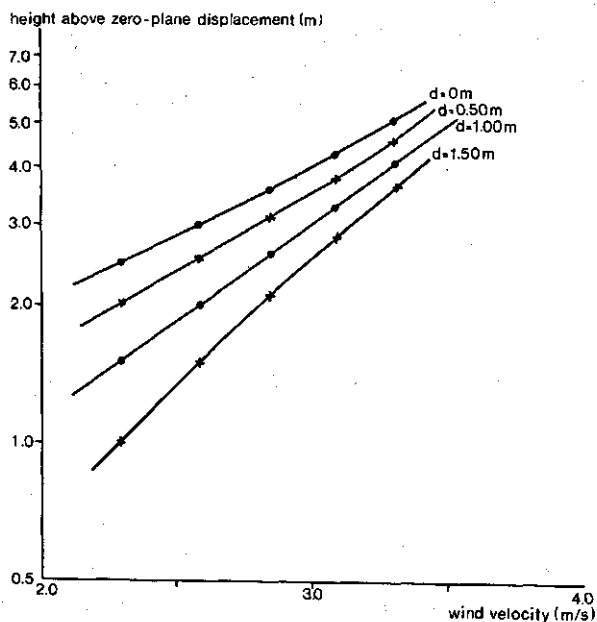

Fig. 3. Graphical method of estimating d , z_0 and u_* from wind-profile measurements. Selecting the best linear curve the best fitting value of d can be deduced ($d = 1.00$ m).

idea about the applicability of the measured wind data over that particular run. If no straight line is obtained, the reason may be found, for instance, in irregularities of the surroundings (Sect. 3.2) or instrumental errors. However one can imagine that a complete evaluation of all measurements along these lines is a time-consuming operation.

In all profile methods to estimate d , z_0 and u_* , the difference in height between the successive wind sensors should be big enough. Otherwise in view of the inaccuracy of the measured wind velocity (e.g. 1%), it is impossible to find a sufficiently accurate d . There should also be sufficient heights of measurement available to observe any discrepancy from the straight line.

Another problem arises when the graphical method is applied to measurements for non-neutral conditions, in which departures from the neutral logarithmic profile occur. These departures must be solved by introducing the stability term (Eq. 22). However they can also be solved erroneously by taking an appropriate d that of course differs from the real zero-plane displacement valid under neutral conditions. Of course, this uncertainty is eliminated at once when d is independently given from other sources.

A method to describe the influence of non-neutral atmospheric conditions on the wind profile is presented by Webb (1970). So an effort has been made to use his approach to estimate d . But, in fact, it appears that this method too can only be applied if an accurate d is available independently. To estimate d , this method is therefore less attractive.

2.2.2 Regression analysis by the method of least squares

For every measuring run d , z_0 and u_* can be estimated by regression analysis by the method of least squares. Robinson (1962) has developed a computing program to calculate these wind profile parameters, using this method. A subprogram for standard errors was added by Covey (1963). More recently, Stearns (1970) developed another program, also using the method of least squares.

The computing method is based on the existence of a logarithmic wind profile, which means that Equation 26 holds for any particular height. Application of the method of least squares leads to a function E that is defined as

$$E = \sum_{i=1}^n \left[\bar{u}_i - (u_*/k) \ln \frac{z_i - d}{z_0} \right]^2 \quad (27)$$

where \bar{u}_i is the measured value. From the demand that function E should be minimized, it follows that

$$\partial E / \partial u_* = 0, \quad \partial E / \partial d = 0 \quad \text{and} \quad \partial E / \partial z_0 = 0 \quad (28)$$

After elimination of z_0 and u_* , an implicit equation only depending on the unknown d can be obtained (App. 1). This equation can be solved by iteration. Thereupon u_* and z_0 are computed by substitution. The method is used by, for instance, Allen (1968), Randall (1969), Lemon & Wright (1969) and Munro & Oke (1973).

From a physical aspect, this method often leads to unacceptable values of d : negative or large positive values, that means a zero-plane displacement below the soil surface or

above the crop canopy (e.g. Sect. 6.2.2; Hicks et al., 1975).

A big disadvantage of both the graphical method and this regression method is that the parameters d , z_0 and u_* are mathematically interdependent. This leads to a close correlation between the fitted value of d and the calculated u_* and z_0 (e.g. Sect. 6.2.3; Legg & Long, 1975). Again in relation to experimental accuracy, this method is sensitive to errors of measurement (App. 2; Tanner, 1963; Kawatani & Meroney, 1970). Before use of this method, a qualitative evaluation of the whole profile should be drawn by means of a graphical representation. It must be emphasized that like the graphical method, the regression method can be used only for neutral conditions.

2.2.3 Empirical relationships of crop parameters

Experimental estimation of d and z_0 may appear difficult or even impossible because of inaccuracy of measurement, an insufficient number of heights of measurement, too small a fetch or non-neutral atmospheric conditions. Therefore in many experiments, it is more attractive to use fixed values of d and z_0 calculated independently from empirical relationships. Several investigators derived regression equations showing simple relationships between both d and z_0 and crop canopy height h . These relationships can be read as

$$\begin{aligned}\log d &= a_1 \log h + b_1 \\ \log z_0 &= a_2 \log h + b_2\end{aligned}\tag{29}$$

Different experiments show a large range of values of the empirical constants (Tanner & Pelton, 1960; Stanhill & Fuchs, 1968; Stanhill, 1969; Szeicz et al., 1969). Also linear relationships have been proposed:

$$\begin{aligned}d &= c_1 h \\ z_0 &= c_2 h\end{aligned}\tag{30}$$

The available data of d and z_0 are too scattered to justify an effort to distinguish which of these two models would be more reliable. So the latter, being the simplest, is preferred.

Of course in this approach again a large range of values of the constants c_1 and c_2 are found, depending on circumstances like type of vegetation. To illustrate the variability in d and z_0 , it is mentioned that Cowan (1968) found $d = 0.64 h$; from wind tunnel experiments Plate & Quraishi (1965) deduced $d = h$; Monteith (1973) stated that $d = 0.63 h$ and $z_0 = 0.13 h$ should be valid for many crops as a reliable average; Legg & Long (1975) found $z_0 = 0.14 h$; Thom et al. (1975) deduced $d = 0.76 h$ and $z_0 = 0.06 h$. Looking at this variety, one can imagine that the use of fixed values of c_1 and c_2 leads to too large discrepancies of d and z_0 in a particular experiment (e.g. Thom et al., 1975).

Therefore some investigators related d and z_0 also to other characteristics of the vegetation. Kondo (1971) introduced an extinction coefficient of wind velocity within the crop canopy layer. Lettau (1969) expressed z_0 in terms of structural properties of

surface obstacles. However in this way again, complicated measurements are needed and thus, for more practical purposes, it is worthwhile investigating within what limits the simple relationships of Equation 30 can apply.

The same holds for the method of Goudriaan (1977) who presents an interesting derivation of z_0 and d from matching conditions between the wind profiles within and above the crop canopy. As no experimental data were collected inside the crop in the present work, the approach could not be applied here.

2.3 COMPARISON WITH EDDY-CORRELATION METHOD

In the foregoing sections was demonstrated, that when the profile method is used for the determination of the vertical transport of momentum the quantities d , z_0 and u_* had to be known before the shear stress τ can be estimated. The evaluation of d , z_0 and u_* from the profile method is often difficult and the estimate of u_* depends closely on the estimates of d and z_0 .

With the eddy-correlation method τ and so u_* can be deduced directly from the measurements. Therefore a comparison of the results of both methods may be useful to check the accuracy of the estimated u_* .

2.3.1 Eddy-correlation method

To derive the vertical transports of momentum and heat from eddy-correlation, the turbulent fluctuations of wind and temperature should be recorded (Munn, 1966; Rose, 1966). The turbulent transports of momentum and sensible heat can usually be represented as

$$\tau = -\overline{\rho u'w'} \quad (31)$$

$$H = \rho c_p \overline{w'T'} \quad (32)$$

Thus these fluxes are estimated by correlation of the different turbulent fluctuations at the same height over an appropriate run.

With Equations 10 and 31, the friction velocity can be calculated by correlating u' and w' , so that $u_*^2 = -\overline{u'w'}$. The mean shear stress τ can be considered as constant in the lower part of the surface boundary layer under certain conditions (Sect. 2.1.1). Within that lower layer, the shear stress is independent of the height of measurement and so measurements can be taken at any height within this layer. Another advantage of this method is that u_* is estimated independently of the zero-plane displacement.

However to measure the fluctuations, sensors should be used that are capable of sensing high-frequency fluctuations. This means in the lower atmosphere, fluctuations up to about 10 Hz (McBean, 1972). So for this eddy-correlation technique, expensive and complicated equipment is needed.

2.3.2 Drag coefficient

According to the literature (Tanner, 1963; Munn, 1966; Lemon & Wright, 1969) an aerodynamic crop canopy resistance can be expressed as the drag coefficient on any height z

$$C_d = (u_* / \bar{u})^2 \quad (33)$$

This can also be written as

$$c = C_d^{\frac{1}{2}} = u_* / \bar{u} \quad (34)$$

The logarithmic wind profile (Eq. 13) and Equation 34 show that

$$c = k / \ln ((z - d) / z_0) \quad (35)$$

From the eddy-correlation measurements the coefficient $c = u_* / \bar{u}$ can be estimated and then a set of values for d and z_0 can be found with Equation 35.

When the wind-profile method is used also u_* had to be estimated from the measurements and so d , z_0 and u_* are mathematically interdependent, while with the eddy-correlation method only d and z_0 are interdependent and u_* is a fixed measured value. Therefore one can expect that if data on eddy-correlation and wind-profile method are compared, the zero-plane displacement can be estimated more accurately than from wind-profile measurements alone.

3 Conditions of measurement

In this chapter, some conditions will be discussed in regard to the experimental field and the measuring arrangement for application of the profile method. From the assumptions in Section 2.1.1, the air flow above the canopy should be horizontal, homogeneous and in steady state. This means that the experiment must meet several requirements. For instance, sufficient fetch must be passed by the air flow to warrant a well developed boundary layer; measurements are averaged over a certain run duration that must be sufficiently long; the observation height must be chosen within the boundary layer. Also the influence of the mast merits attention. Each of these aspects will be treated in the next sections of this chapter.

3.1 APPROPRIATE RUN DURATION

The flow over a crop will approximately satisfy conditions of steady mean flow. Irregularities in the crop canopy, variations in wind direction or cloudiness can cause temporary and spatial fluctuations. So the equilibrium layer adapted to the surface roughness can be disturbed for short periods and the run should be long enough to smooth these disturbances. If, however, a long run duration is chosen, care must be taken that the diurnal trend should not influence the data.

Tanner (1963) states that the run duration depends on height of measurement, since the size scale of the largest eddies increases with the height above the surface. If measurements are taken near the surface, for instance within 2 to 4 metres, runs must be 10 to 30 min.

The size of the experimental field and the wind velocity over the field contribute to determine the run duration. If the mean wind velocity over a 300-m field (as in this experiment) is about 3 m/s, the average travel time over the field is 100 s. In a run of 10 min only 6 field-sized eddies can cross the field. Usually in profile measurements, a run of 30 min is chosen. During this period, 15 or 20 field-sized eddies can pass a 300-m field and thus the average is more representative of air flow.

3.2 FETCH

An air flow can be regarded in equilibrium with the underlying surface, only if it is passing steadily along a certain horizontal path over an area of homogeneous roughness. In this context, equilibrium means that the shear stress is constant throughout the air layer and equal to the shear stress at the surface. The flow characteristics within this equilibrium layer are determined largely by the surface properties. This layer, adapted to the underlying surface, may be regarded as steady and homogeneous. Only under these

conditions will the wind profile be logarithmic (Sect. 2.1.1). Therefore in the present research, wind profile will be measured in such an equilibrated or adapted layer.

If surface roughness changes, as usually in agricultural fields where different crops are growing next to each other, the air flow gradually adjusts to the new surface and a new equilibrium layer results. For correct measurement of the profile, one must know how the adapted layer is developing downstream of the change in surface roughness. Several investigators have dealt with this problem, for instance, Elliott (1958), Taylor (1962), Dyer (1963), Rider et al. (1963), Panofsky & Townsend (1964), Bradley (1968), Blom & Wartena (1969), Peterson (1969, 1972), Taylor (1969), Shir (1972), Rao et al. (1974) and Munro & Oke (1975). Most contributions are theoretical and only a few experiments are reported.

But first a few general aspects. Fetch is the horizontal distance the air has passed downstream of a change in surface roughness. The height of the adapted layer depends on the fetch. As the height of the new adapted layer increases slowly - and a transition layer will occur too (Fig. 4) - a large fetch is required to allow measurements in a fully adjusted layer. The adapted layer and the transition layer together are sometimes called the internal boundary layer.

Some theories about adjustment of the surface air layer after a change in surface roughness are based on the momentum equation, the continuity equation and a third equation. This third equation usually introduces an assumption a priori about the vertical distribution of mean wind velocity, shear stress or another relevant quantity. For instance the logarithmic wind profile is applied by Elliott (1958), Taylor (1962) and Panofsky & Townsend (1964).

Elliott (1958) developed a simple model where the transition zone is supposed to be very thin so that it may be represented by an interface. On both sides of this interface, the logarithmic wind profile applies, u_* is independent of height and equals u_* at the surface. The interface occurs at a level $h(x)$ that depends on the distance downwind of the change in surface roughness. Elliott derived from this model an expression for the growth of the height $h(x)$ with the distance x downwind: $h(x) = ax^{0.8} z_0^{0.2}$ where the coefficient a depends on the ratio of upstream and downstream roughness, and z_0 is the roughness length downstream.

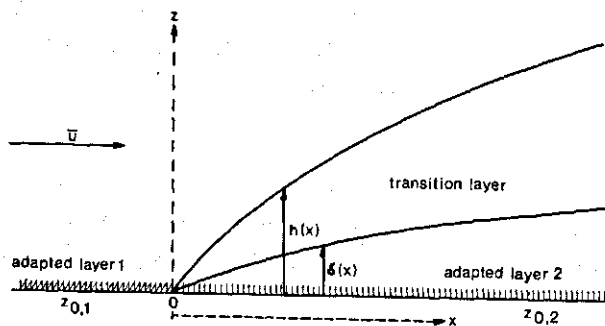

Fig. 4. Development of an internal boundary layer after a change in surface roughness.

Taylor (1962) introduces a more substantial transition zone within which the shear stress τ and so the friction velocity u_* depends on height. Outside the transition zone, the logarithmic model applies again and the shear stress is assumed to be constant. Only a parameter representing a scale length of the transition zone is introduced. This quantity is calculated from the roughness lengths and friction velocities both upstream and downstream of the change in surface roughness. From this model, Taylor suggests that a distance of 150 times the height of observation should be adequate in many experiments.

Panofsky & Townsend (1964) also start from the model developed by Elliott (1958). However they assume a friction velocity that is proportional to height. The assumed model of the wind profile is represented by a logarithmic linear relation with a linear term depending on the interface height. The slope of the interface of the Panofsky-Townsend model is roughly $h(x)/x = 1/10$.

Other theories relied on exchange coefficient or mixing length, instead of the assumption a priori of velocity profiles (Townsend, 1965; Nickerson, 1968; Blom & Wartena, 1969; Taylor, 1969). Blom & Wartena (1969) state that in the theoretical model developed by Townsend (1965), an adapted layer cannot exist, as a consequence of excessive simplification. They amend the model of Townsend and conclude that an adapted layer does occur only for a fetch of several kilometres. Since a fetch of that length can seldom occur, they extend the modified theory to two subsequent abrupt changes in surface roughness.

In general, the models agree reasonably well with the few observations in prediction of the velocity profiles. Considerable differences, however, occur in the calculated surface shear stresses. To test these model predictions, accurate and sufficiently detailed measurements in the atmosphere should be available. However in most experiments, surface shear stress and stress profiles are not measured and sometimes the data are too scattered. So it is difficult to test thoroughly the models against field measurements and to draw a conclusion about their validity.

In one respect, there is a considerable difference between these model predictions and some experimental data reported in the literature (Bradley, 1968; Echols & Wagner, 1972; Panofsky & Petersen, 1972; Petersen & Taylor, 1973). In these experiments, kinks or inflexion points occur in the measured wind profiles, but calculated wind profiles do not reproduce this phenomenon. This kink does appear in models more recently developed by Peterson (1969), Shir (1972) and Rao et al. (1974). These investigators did not assume anything a priori about the wind velocity or shear stress. They start, as before, from the momentum equation and continuity equation, but they insert the complete turbulent energy equations, instead of these assumptions a priori. Solutions are obtained by numerical methods. Peterson (1969), Shir (1972) and Rao et al. (1974) all found the kink in the wind profile, though they used slightly different approaches. By these numerical approaches, the distribution of wind velocity, shear stress and wind shear after a change in surface roughness was computed and the development of the adapted air layer could be indicated more accurately.

From all these approaches the height-to-fetch ratio can be estimated. Table 1 shows some data deduced from either theoretical models or experiments. These results are related to the height of the internal boundary and the adapted layer, respectively. The growth of the internal boundary layer is mostly reported as proportional to a 4/5 power.

Table 1. Height-to-fetch ratios derived from theoretical approaches or experiments.

	$h(x)/x$ ^a	$\delta(x)/x$ ^b
Elliott (1958)	1/10	
Taylor (1962)		1/150
Panofsky & Townsend (1964)	1/10	
Bradley (1968) ^c		1/200
Peterson (1969)	1/10	1/100
Echols & Wagner (1972) ^c	1/10-1/20	
Shir (1972)	1/20	1/100-1/200 ^d

a. $h(x)$ = height of the internal boundary layer.
 x = distance downstream of the change in surface roughness.

b. $\delta(x)$ = height of the adapted layer.

c. Data derived from experiments.

d. 1/100, smooth to rough surface; 1/200, rough to smooth surface.

In practice this is often linearized. The table shows that the ratio of the height of the internal boundary layer and the fetch approaches a practical value of 1/10. In small-scale micrometeorological experiments a rule of thumb is often used for the ratio of the height of the adapted layer and fetch $\delta(x)/x$ of 1/100. In the literature, however, different values of these ratios are met (Table 1). Some of the following considerations could account for these discrepancies.

Firstly not always an explicit distinction has been made between the internal boundary layer and the adapted layer (Elliott, 1958; Panofsky & Townsend, 1964). Bradley (1968) and Peterson (1969) found that the adapted layer includes only the lower 10 to 15% of the internal boundary layer. Shir (1972) and Rao et al. (1974) distinguished an internal boundary layer that referred to a velocity profile and another layer related to shear stress. The height of the stress layer should be twice the height of the velocity layer.

Secondly the nature of the roughness downstream of the change in surface roughness affects the development of the adapted layer. In particular, a flow encountering a new surface with higher obstacles will adjust more quickly (Elliott, 1958; Shir, 1972; Munro & Oke, 1975). According to Shir (1972), the height-to-fetch ratio $\delta(x)/x$ should be 1/100 for a smooth to a rough surface, however 1/200 for the reverse situation. Munro & Oke (1975) described an experimental approach deducing equilibration of the boundary layer above a tall crop (wheat) where the zero-plane displacement is not negligible. They state that usually for most crops the adapted layer is much thicker than 0.01 times the fetch.

Thirdly experiments by Panofsky & Petersen (1972) and Echols & Wagner (1972) show that atmospheric conditions can affect the height of the internal boundary layer and thus of the adapted layer. Based on his numerical model, Rao (1975) deduces the following relationships between the height of the internal boundary layer $h(x)$ and the fetch x :

neutral conditions	$h(x) \sim x^{0.8}$	
unstable conditions	$h(x) \sim x^{0.9}$	$L = -20 \text{ m}$
strongly unstable conditions	$h(x) \sim x^{1.4}$	$L = -2 \text{ m}$

where L is the Monin-Obukhov length.

Thus the height-to-fetch ratio depends on field situation and atmospheric conditions. Mostly the rule of thumb $\delta(x)/x = 1/100$ will provide a larger fetch than is actually required for maximum observation height. However we can take it as a safe criterion. With this ratio, the upper level of measurement will certainly be within the adapted layer.

In this context, the kink in the velocity profile is an important phenomenon. In the adapted air layer above a crop, the logarithmic wind profile holds. The occurrence of the logarithmic wind profile below the kink in the transition zone can be used to check the height of the adapted layer. For measurements above a tall crop with a rather small fetch, the number of heights of measurement is often insufficient to show the validity of the logarithmic model. But now a kink in the wind velocity profile may indicate approximately the upper boundary of the adapted layer. Thus by means of this kink the actual ratio of the height of the adapted layer and the fetch can be roughly deduced from experiments.

3.3 MAST EFFECTS

In general the equipment to measure wind profiles will disturb the wind pattern over the plot. An effort should be made to minimize these disturbances. The sensors should be mounted on the mast in such a way that mast influence is reduced as much as possible. Experiments to investigate the influence of the mast on wind velocity measurements have been described, for instance, by Rider (1960), Moses & Daubek (1961), Gill et al. (1967), Dabberdt (1968) and Izumi & Barad (1970). Mostly the experiments were with tall towers: radio transmitters, forest lookouts, towers and smoke stacks. There have been many experiments with wind tunnels.

From the literature, some recommendations can be adopted:

1. The distance between the sensor and the mast should at least equal the diameter of the mast. A distance of one and a half times the diameter should be preferred. Disturbances can be minimized by mounting the sensor on a long bar fixed to the mast. However the position of the sensor at the end of the bar must be fixed accurately and this restricts the length of the bar considerably. In the first place, it is difficult to maintain a long and not too thick bar for a long time in the same horizontal position. In the second place, uncontrolled sagging or bending of the long bar will lead to unacceptable movement.
2. In view of the facts summarized in the foregoing, a sensor mounted at the windward side of the mast records a wind velocity close to the undisturbed value. A sensor mounted perpendicular to the wind direction or at the downwind side of the mast records a wind velocity higher or lower than the undisturbed value (Gill et al., 1967; Dabberdt, 1968).
3. Open towers disturb the wind less than solid towers. With an open tower, those parts of the tower with few crossbars should be selected to mount the sensors, especially on large towers.

3.4 NUMBER AND MINIMUM DIFFERENCE IN HEIGHT OF THE SENSORS

The level of the highest and the lowest sensor and the number of sensors desired will limit the difference in height between sensors. The maximum height of measurement depends on the ratio between the height of the adapted layer and the fetch and the fetch actually available. The minimum height of measurement is determined by the height and the roughness of the crop or the surface. The sensors close to the surface are strongly influenced by local irregularities and so do not represent the average profile (Tanner, 1963). According to Lettau (1959), it is advisable to choose the lowest level above the crop at a height of at least five times the roughness amplitude of the crop. The roughness amplitude is half the height of the roughness elements.

Thus the levels of the highest and lowest sensor are related to field size and to nature of the surface. Consequently the difference in height between the highest and lowest height of measurement is highly restricted. Thence some requirements should be put forward about the minimum difference in height between the successive sensors.

At least three heights of measurement are necessary to determine d , z_0 and u_* (Sect. 2.2). However with only three heights, a considerable inaccuracy may occur and therefore five or more heights of measurement are usually needed. Because of the logarithmic relationship heights in logarithmic sequence are preferred. But this is unfeasible in experiments above a tall crop with an unknown zero-plane displacement.

In experiments above a tall vegetation with a certain fetch and with considerable influence of the surface obstacles, it is realistic to expect only a thin layer suitable for measurements. If so, the difference in height between the sensors will be small. The estimate of d , z_0 and u_* is then highly inaccurate (Sect. 2.2).

To prevent mast influence and mutual interference between the sensors each sensor is sometimes mounted on its own mast (Biscoe et al., 1975). Because of insufficient fetch or uncertainty about irregularities in the crop surface, measurements on one mast are often preferred. All sensors should then be placed upwind of the mast and in line, to minimize the mast influence.

The minimum difference in height between the successive sensors depends on the size of the sensor. In micrometeorology a difference in height of 25 to 50 cm is mostly accepted. As a rule of thumb, this distance can be taken as about 10 times the size of the sensor housing (Tanner, 1963).

4 The experiments

The experiments reported form part of a project to investigate the profile method. This project includes eddy-correlation measurements and measurements of the total energy balance. Only the measurements and results for the wind-profile method will be described here. The other work will be published elsewhere.

Measurements were taken in the years 1974, 1975 and 1976 during the months of June, July and August above a 10 ha field of maize (*Zea mays*). During 1975 and 1976, simultaneous measurements were taken above a pasture. These experimental fields were on the Experimental Station of the Agricultural University, the Ir. A.P. Minderhoudhoeve near Swifterbant in East Flevoland (Fig. 5).

To obtain correct data, several requirements must be satisfied: sufficient fetch (Chap. 3); a uniform and regular crop canopy; and 'ideal' weather. The main measurements were taken above the full-grown crop, at which stage the crop does not change in height and a sufficient number of comparable measurements can be taken. So the main measurements should be taken in August (Sect. 4.2). In the previous months, the equipment and instruments must be tested in the field.

Ideal weather is dry and sunny with moderate north-easterly wind (Sect. 4.2.1). Such weather occurs when a steady high-pressure area prevails over Western Europe with the centre above the British Isles. In 1974, extremely bad weather almost prevented the planned preliminary testing of the equipment and arrangement. Also failure of equipment sometimes reduced the number of suitable days. So not more than a few days in a season gave successful and reliable measurements.

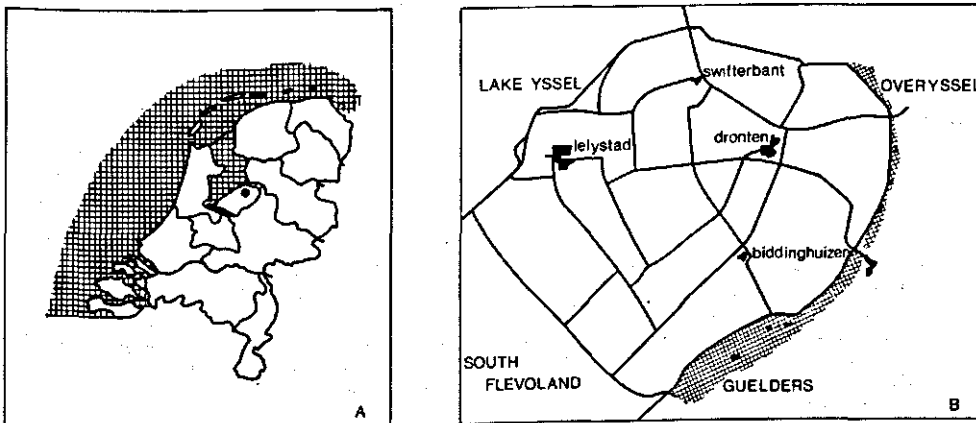

Fig. 5. Situational sketch. A. The Netherlands; B. East Flevoland.

In this chapter also equipment used and recording of the data are described. Equipment for wind-profile measurements will be described in detail and that for energy balance and eddy-correlation method only briefly.

4.1 WEATHER DURING MEASUREMENTS

The weather should be sunny and dry with a north-easterly wind for adequate measurements. In summer, this is a rather common type of weather, normally about 6 days in July and about 6 days in August.

In 1974, the summer was cold and wet (Table 2) and the planned measurements could not be adequately performed in this period. More specifically the testing period in June and July was lost and too small a sequence of data was obtained. Therefore no conclusions could be drawn on mast effects and discrepancies in the wind profile. Thus some measurements had to be repeated in 1975.

The weather in 1975 was more suitable and many measurements were taken. However some problems remained and extensive measurements were taken in 1976. Modifications in the arrangement and equipment introduced in 1975 and 1976 will be described in Section 4.2.2.

In 1976, the weather was much better. In June, July and August there was a long dry period. The wind during these periods always came from the north-east, though on many days it turned too far to the east. Part of the data from 1975 could be interpreted and elaborated with the data from 1976.

Table 2. Weather before and during measurements. Numbers in parentheses represent the simultaneous observations in De Bilt.

	Temperature ($^{\circ}$ C)			Total rainfall (mm)	Days ^a			
	monthly mean	mean max.	mean min.		1	2	3	4
June								
1974	14.5 (14.8)	19.4 (19.5)	9.1 (9.7)	46.0 (86.7)	18	12	5	
1975	14.6 (15.0)	19.4 (20.2)	8.9 (9.4)	21.0 (85.5)	19	14	6	
1976	17.1 (18.0)	22.6 (23.6)	10.1 (11.2)	21.4 (52.8)	24	6	1	
normal	(15.5)	(20.7)	(10.1)	(58.0)				
July								
1974	15.2 (15.4)	18.6 (19.1)	10.9 (11.3)	102.5 (82.8)	12	-	-	
1975	16.9 (17.8)	21.4 (23.3)	12.1 (12.6)	55.8 (24.8)	16	11	2	
1976	18.4 (19.4)	23.9 (24.9)	12.1 (13.1)	18.9 (43.4)	18	12	3	
normal	(17.0)	(21.9)	(12.2)	(76.8)				
August								
1974	16.3 (16.4)	21.3 (21.6)	10.7 (10.7)	59.5 (77.8)	19	8	3	-
1975	18.9 (19.9)	24.7 (26.1)	13.2 (13.8)	45.5 (41.6)	23	9	2	4
1976	17.2 (18.0)	23.3 (24.0)	11.0 (11.9)	17.6 (16.4)	23	19	7	5
normal	(16.8)	(21.8)	(12.0)	(88.0)				

a. 1 = number of days without rainfall; 2 = number of days without rainfall and with N-E wind; 3 = weather as 2, but over a weekend; 4 = number of days with successful measurements above a full-grown crop in August.

At the end of a period of measurement of, for instance, two or three successive days, all sensors were removed to avoid any damage by birds or bad weather. Consequently, before the next period of measurement the sensors had to be mounted again and the equipment checked. These time-consuming operations had to be performed the day before measurements began. If the weather changed for the better rapidly preparations had to be done under conditions suitable for the measurements, so that a few days suitable for measurements were lost.

A team of about 10 persons was required for preparations and measurements. As the distance between the Experimental Station and the Laboratory of Physics and Meteorology is about 100 km, it was practically impossible to begin measurements in a weekend and so again some suitable days were lost. Useful data could be collected on only a few days (Table 2). Table 2 does not mention the days lost through instrumental failure, that also reduced the number of days with successful measurements.

4.2 EXPERIMENTAL FIELD AND CROP

The 320 m x 320 m field of maize (Fig. 6, Plot 5 and 6) was situated in a large area of flat arable land and grassland. Figure 6 shows that the north-east as well as the south-west side of the field was bordered by a concrete road and a small ditch, the north-west side by a drainage canal. The surrounding land on the north-east and the south-east side, was covered with grass, on the south-west and north-west side with agricultural crops, such as potatoes, winter wheat or barley. The buildings of the Experimental Station lie about 500 m to the east of the central measuring plot in the maize field.

To satisfy the requirements for the logarithmic profile to be valid, the canopy surface must be uniform and homogeneous. Irregularities in crop height and density should not occur.

Sowing was to a special pattern to obtain a regular crop structure. The corn seed was sown in a rectangular pattern on the central 5 ha (Fig. 7). In this planting pattern, the row distance was 0.40 m and the number of plants in the row was 3 per metre, interval 0.33 m. On either side (NW and SE) of this 5 ha with the rectangular pattern, 2.5 ha was sown in rows with the usual row width of about 0.80 m and the number of plants in the row was about 8 per metre, with an interval of 0.12 m. This usual sowing pattern was applied for agricultural reasons. With the special sowing pattern on the central 5 ha, the effects of the rows on the air flow could be neglected and the wind encountered the same crop structure independently of direction. Further the measuring equipment was erected and handled carefully to avoid damage to the maize plants. Gaps in the canopy near to the masts, where the seed had not emerged were closed by transplanting in an early stage from elsewhere in the field. A few footpaths in the maize were necessary to approach to the masts, for instance to fix and remove the sensors.

Figure 8 shows the development of the maize crop. In the three years of the experiments, different varieties were grown (Table 3). For the experiments, however, the differences between these varieties can be neglected. Both varieties are slightly sensitive to cold weather and in June and July 1974 and in June and the first week of July 1975 the maize did not grow as fast as in the same period of 1976, because the mean temperature

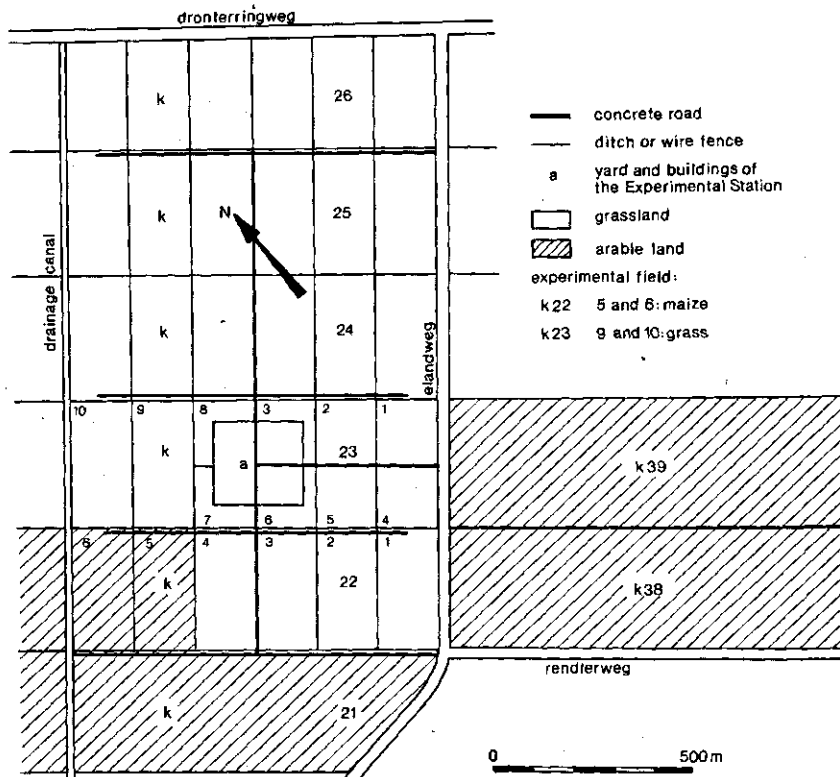

Fig. 6. Experimental field.

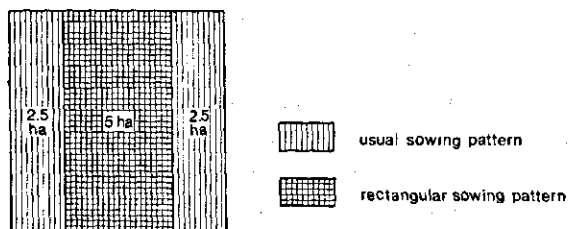

Fig. 7. Sowing patterns.

Table 3. Data on the maize crop.

	1974	1975	1976
Cultivar	Capella (Caldera 535)	Leopard	Leopard
Number of seeds sown per ha	100.000	120.000	100.000
Sowing date	17 April	6-8 May	5-6 May
Date of emergence	c. 16 May	c. 25 May	c. 15 May
Date of harvest	1-2 November	8-10 October	24-25 September
Yield (kg/ha)	39.500	37.150	45.640

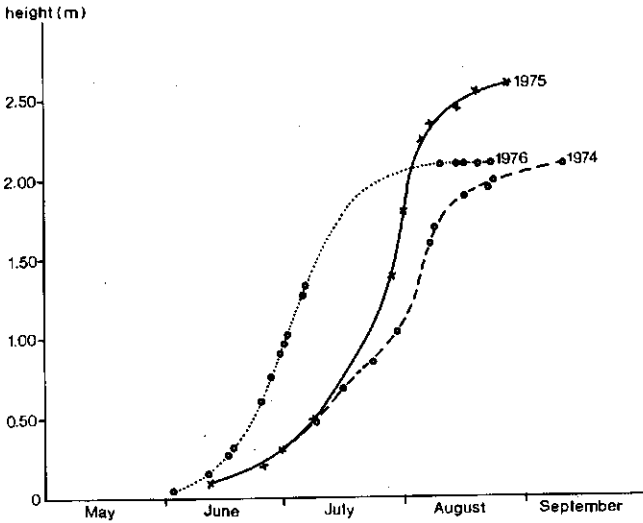

Fig. 8. Development of the maize crop.

was considerably higher during that period in 1976. The lower final height of the crop in 1976, already reached early in August, was caused by extremely dry periods in July and August, and the plants looked different. A high tillering had occurred and consequently the number of tillers with ears increased.

The experimental grassland was ordinary pasture, also belonging to the Experimental Station. It was situated to the north-east of the maize field. During the measurements in 1975, the height of the grass was about 10 cm. In 1976, the grass withered with the drought. So the pasture on the left (Fig. 6, Plot 10) was covered with dry thin grass 10 to 20 cm tall; the pasture on the right (Plot 9) was closely grazed and the grass was about 5 cm high.

4.2.1 Measuring plot

The measuring plot was selected on the south-west side in the experimental maize field. A measuring plot situated on this side of the field provided a fetch as large as possible in weather suited to the measurements (Sect. 4.1). The measuring plot was about 40 m away from the downstream edge of the maize field. It seems not advisable to place it nearer to this edge, where a small ditch and a change in surface roughness may influence air flow upstream. For a wind direction from the north-east just over the field, there was a minimum fetch of about $320 \text{ m} - 40 \text{ m} = 280 \text{ m}$. Figure 9 illustrates the dependence of fetch on wind direction.

For measurements above the grass, equipment was placed on the pasture to the north-east of the maize field (Fig. 6). Plot 9 and 10 were separated by a wire fence. In principle, the equipment could be erected on either side of this wire fence. The choice depended on the prevailing wind direction and the grazing schedule. In 1975 the measuring plot was in Plot 10, in 1976 measurements were on Plot 9 and Plot 10.

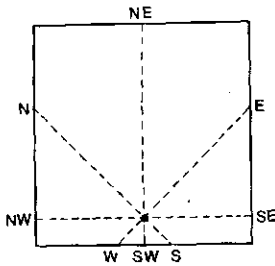

Fig. 9. Fetch over the maize field. NE = 280 m; E = 225 m; SE = 160 m.

4.2.2 Measuring arrangement and equipment

The measuring equipment of the three successive measuring seasons will be described chronologically. This description is preceded by some general considerations on choice of type of mast.

In 1974, triangular lattice-type masts were used in profile measurements. These masts were preferred for their construction: three vertical stakes 0.19 m apart and horizontal crossbars at regular vertical distances of 0.57 m. These crossbars served also as a ladder, that made the sensors easily accessible for mounting, adjusting and removing. However nothing was known about the influence of this mast on air flow. From the few preliminary measurements in 1974, no definite conclusions could be drawn about mast effect.

Cylindrical masts with a diameter of 28 mm were used for measuring wind profiles in 1975. These masts were chosen because mast effects here could be neglected. However difficulties arose in mounting the sensors at a height of about 3 m or more above ground level: extension ladders were necessary. These ladders, however, staying the whole season at the downwind side close to the mast, could also influence the microclimate. Also the frequent use of the sliding part of these ladders might damage the maize plants. An advantage of cylindrical masts was that the sensors could be mounted at any height, as distinct from the triangular masts where the choice was restricted.

All these difficulties about the choice of measuring masts were reasonably solved in 1976. In the arrangement of that year, both types of masts were used, to profit from the benefits of each: less influence on wind velocity for cylindrical masts and easier access with the triangular masts. The sensors were mounted on the cylindrical masts. The triangular masts were placed 0.5 m downwind of the cylindrical masts and served as ladders (Photo 1). The cylindrical masts were fixed to the triangular masts by three cross-strips at different levels. It was expected that this construction had less influence on microclimate than extension ladders.

Figure 10 shows the measuring arrangement in 1974. The main purpose of this arrangement was to determine mast effects and to check the horizontal uniformity of the air flow. This equipment is described only briefly here, since the definitive data were collected later, in 1975 and 1976. Bad weather in June and July hindered preliminary measurements that were necessary for correct profile measurements in August.

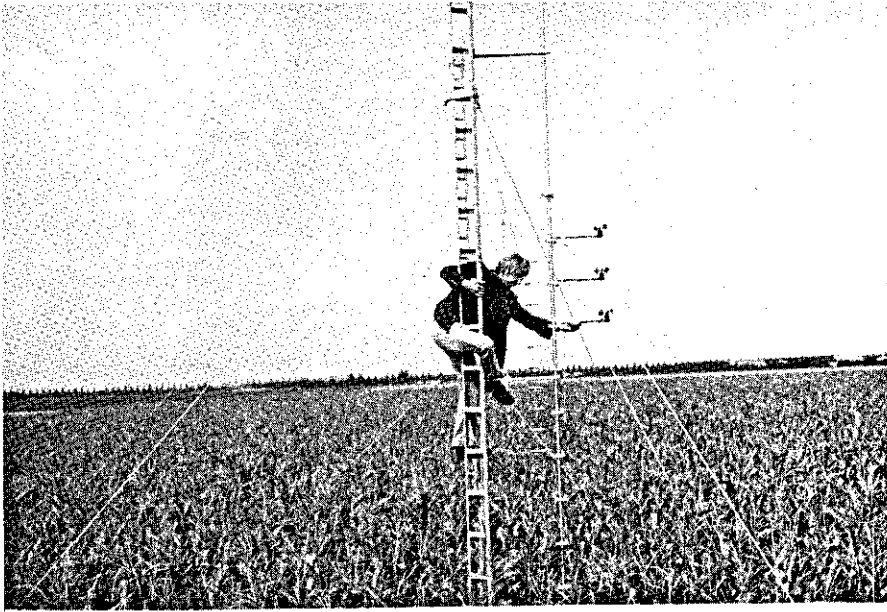

Photo 1. Mounting cup-anemometers (1976).

Each of the Masts 1, 2 and 3 was used for profile measurements of wind velocity, temperature and humidity. Wind velocity was measured by small cup-anemometers, temperature by platinum-resistance thermometers and humidity by thermocouple psychrometers. Radiation shields (0.20 m x 0.20 m) protected the thermometers and psychrometers. The top view of a triangular mast shows the orientation of the sensors (Fig. 11). For details about the instruments used, see Section 4.3.

The equipment for eddy-correlation measurements was mounted on top of Mast 3. On top of Masts 4, 5, 6, 7 and 8, a Casella cup-anemometer was fixed.

Figure 12 shows arrangements in 1975. The cylindrical Masts 1, 2, 3 and 4 were 6 m high and were fitted for wind-profile measurements. The five heights for wind-profile measurements above the full-grown crop (2.60 m high), were 3.14, 3.71, 4.28, 4.85 and 5.42 m. The triangular Mast 5 (8 m high) was also prepared for wind-profile measurements. Simultaneous measurements on Masts 1, 2 and 5 could be conclusive in relation to mast effects. Measurements on Masts 1, 3 and 4 should give information about the development of the adapted layer over the field.

Thermometers and psychrometers were mounted on the triangular Masts 6 and 7. Contrary to 1974, separate masts were used, so that the radiation shields of the latter sensors did not disturb wind velocity. Figure 13 shows the top view of Masts 6 and 7: two temperature profiles and one humidity profile on Mast 6, and one temperature profile and two humidity profiles on Mast 7. The ten heights of measurement for these profiles were 2.00, 2.57, 3.14, 3.71, 4.28, 4.85, 5.42, 5.99, 6.56 and 7.13 m.

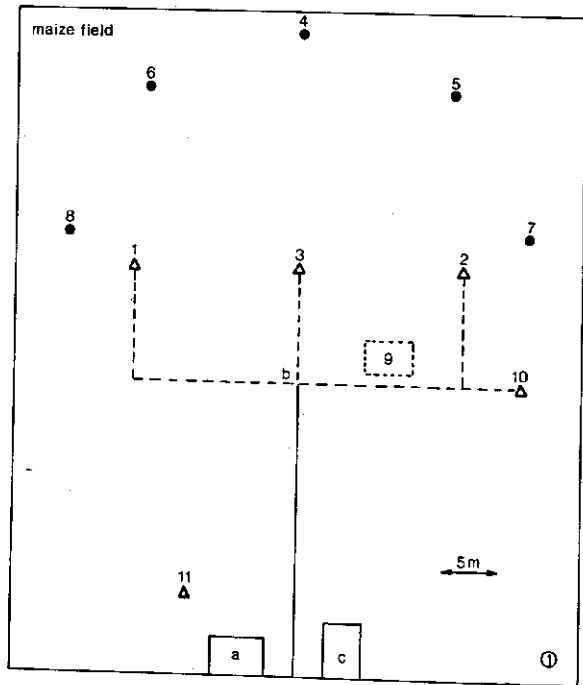
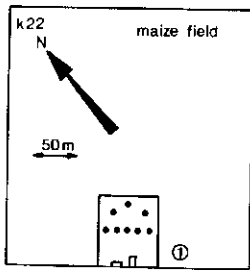

Fig. 10. Arrangement in the field in 1974. 1 = wind, temperature and humidity profiles (8 m); 2 = wind, temperature and humidity profiles (8 m); 3 = wind, temperature and humidity profiles and eddy-correlation; Gill propeller system (6 m); 4 = wind velocity at 3.71 m; 5 = wind velocity at 4.28 m; 6 = wind velocity at 4.85 m; 7 = wind velocity at 5.42 m; 8 = wind velocity at 5.99 m; 9 = soil heat flux; 10 = net radiation at 4 m; 11 = wind direction at 4 m; a = cabin; b = pre-amplifier and scanner of the Modulog system; c = caravan; ● = cylindrical mast (diam. 28 mm); Δ = triangular mast (sides of width 0.19 m); — = footpath; - - - = narrow footpath.

The triangular Mast 8 (4 m high) and the cylindrical Mast 9 (4 m high) were intended for eddy-correlation measurements. Net radiation and wind direction were measured on Masts 10 and 11, respectively. The heat flux in soil was also measured (Fig. 12, Item 12).

Masts 20, 21 and 22 were erected in the pasture upwind of the maize field. The main purpose of the measurements above grass was for comparison. Wind profile was measured on the cylindrical Mast 20 (3 m high). The height of the sensors above the grass was 0.80, 1.30, 1.80, 2.30 and 2.80 m. The cylindrical Mast 21 (3 m high) was intended again for

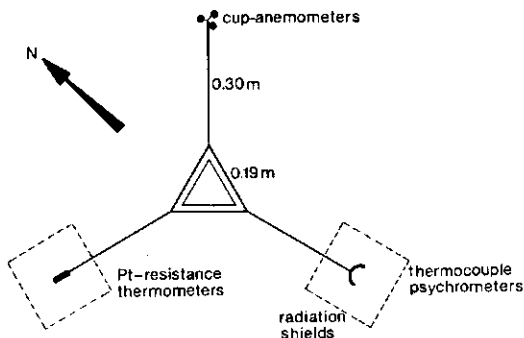

Fig. 11. Top view and orientation of Masts 1 and 2 in 1974. With a north-easterly wind thermometers and psychrometers occupied less suitable positions than cup-anemometers.

eddy-correlation measurements. Net radiation was measured with a net radiometer on top of the cylindrical Mast 22 (1.50 m high). There too the heat flux in soil was measured (Item 23). All these measurements on grass were centrally recorded in the cabin (Fig. 12, Item a) about 350 m from the grassland site.

Figure 14 shows the arrangement in 1976. A combination of triangular and cylindrical masts (Photo 2) was used for profile measurements (Masts 1, 2, 3 and 4). In 1975 the thickness of the layer above the crop in which measurements could be taken had proved to be small. If at least five heights of measurement in the adapted layer were available for the determination of unknown parameters, the difference in height between successive sensors had to be decreased to 0.30 m. To prevent mutual influence of the sensors, the size of the anemometers had to be decreased too (Sect. 4.3.1). In 1975 mast influence was found in the temperature profiles measured at the leeward side of the mast. To avoid this, in the next year only one array of sensors was mounted on each mast, positioned at the windward side. Wind profiles were actually measured on Masts 1 and 2 at heights 3.10, 3.40, 3.70, 4.00 and 4.30 m, when the crop was full-grown (about 2.10 m). Masts 3 and 4 were prepared for temperature measurements at ten heights. During the main measurements, these ten heights were 2.20, 2.50, 2.80, 3.10, 3.40, 3.70, 4.00, 4.30, 4.60 and 4.90 m. Humidity profiles were not measured, because preparation and performance of these measurements would have taken too much time. The equipment for eddy-correlation measurements (Masts 5, 6 and 7) was further elaborated (Sect. 4.3.2). Net radiation and wind direction (Masts 8 and 9) were measured in the same way as in 1975. The heat flux in soil (Items 10 and 11) was measured more extensively than in previous seasons.

Wind profile above grass was measured on the cylindrical Mast 12 (3 m high). A mast for temperature-profile measurements was added to the arrangement on grass. Two arrays of five thermometers were mounted on the cylindrical Mast 13 of 3 m height (Fig. 15). The use of two arrays of thermometers serves several purposes: 1. testing of the thermometers in the field; 2. comparison of the two simultaneously observed temperature profiles; and 3. comparison of the temperature profile above grass and simultaneous temperature profile above a maize crop. The five heights of measurement of temperature and wind velocity were

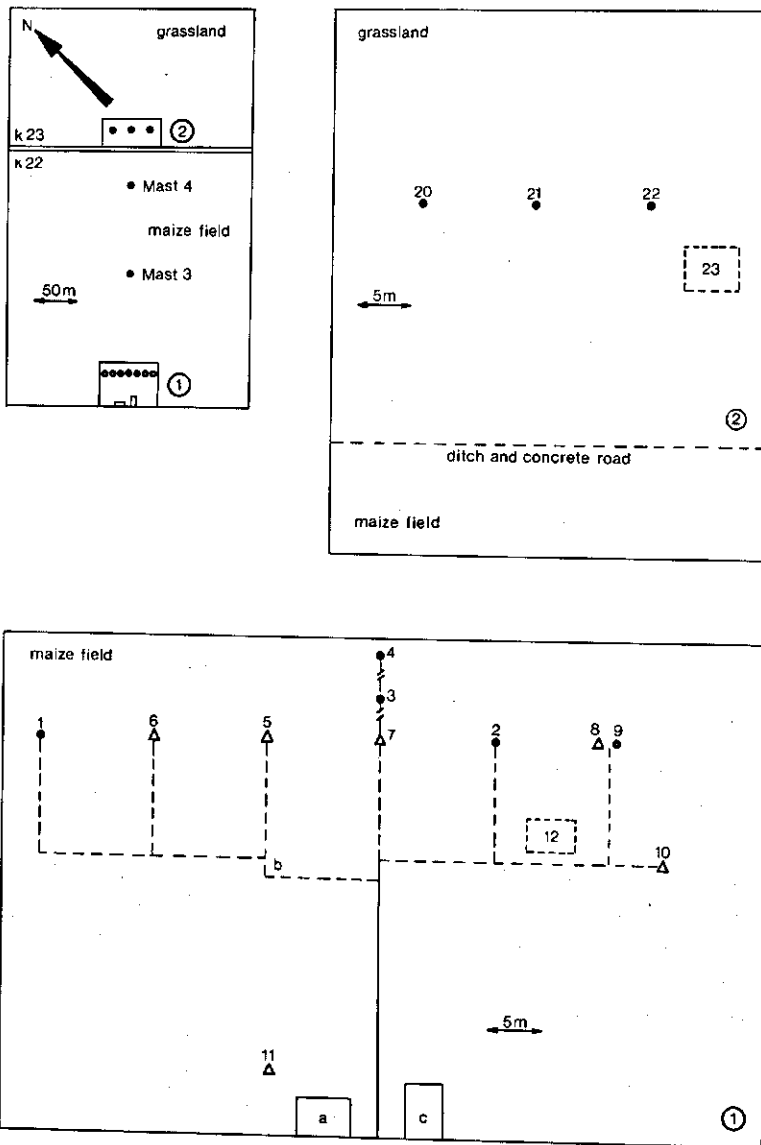

Fig. 12. Arrangement in the field in 1975. 1 = wind profile (6 m); 2 = wind profile (6 m); 3 = wind profile (6 m); 4 = wind profile (6 m); 5 = wind profile (8 m); 6 = temperature and humidity profiles (8 m); 7 = temperature and humidity profiles (8 m); 8 = eddy-correlation: propeller bivariate; 9 = eddy-correlation: Gill propeller system; 10 = net radiation at 4 m; 11 = wind direction at 4 m; 12 = soil heat flux; 20 = wind profile (3 m); 21 = eddy-correlation at 3 m; 22 = net radiation at 1.5 m; 23 = soil heat flux; a = cabin; b = scanner and pre-amplifier of the Modulog system; c = caravan; ● = cylindrical mast (diam. 28 mm); Δ = triangular mast (sides of width 0.19 m); — = footpath; - - - = narrow footpath.

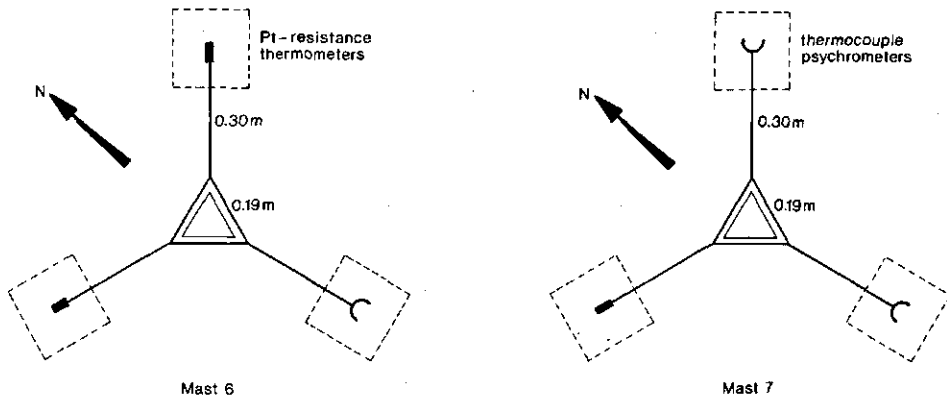

Fig. 13. Top view and orientation of Masts 6 and 7 in 1975.

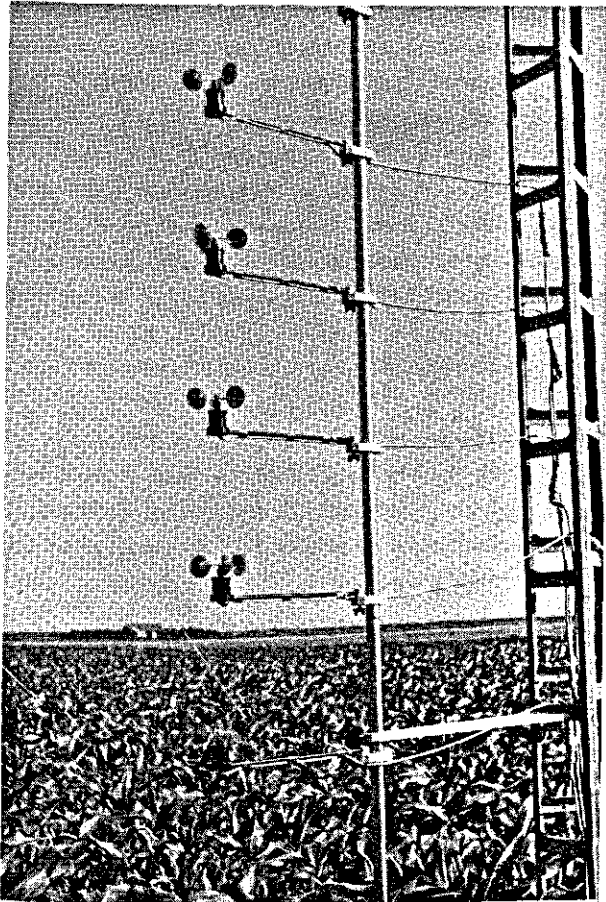

Photo 2. Combination of triangular and cylindrical masts for wind-profile measurements (1976).

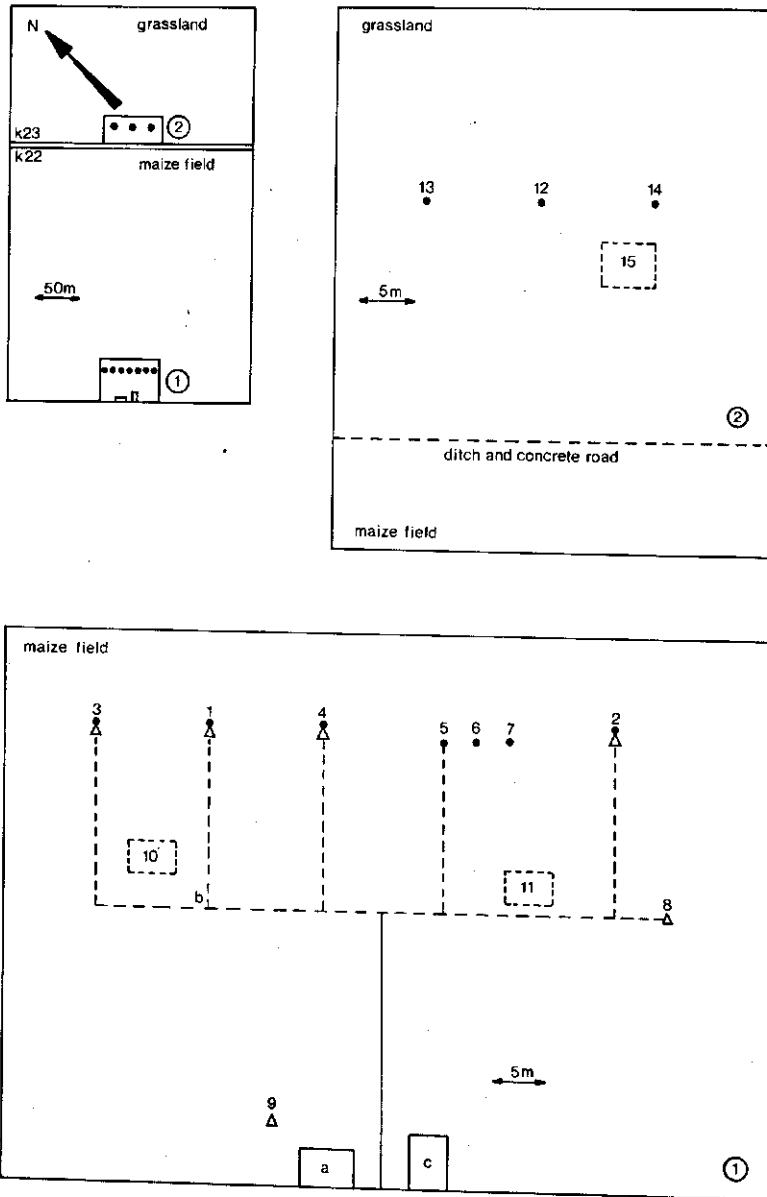

Fig. 14. Arrangement in the field in 1976. 1 = wind profile (6 m); 2 = wind profile (6 m); 3 = temperature profile (6 m); 4 = temperature profile (6 m); 5 = eddy-correlation: Gill propeller system; 6 = eddy-correlation: propeller bivan; 7 = eddy-correlation: hot cross-wire anemometer; 8 = net radiation at 4 m; 9 = wind direction at 4 m; 10 = soil heat flux; 11 = soil heat flux; 12 = soil heat flux; a = caravan; b = scanner and pre-amplifier of the Modlog system; c = caravan; ● = cylindrical mast (diam. 28 mm); Δ = triangular mast (sides of width 0.19 m); — = footpath; - - - = narrow footpath.

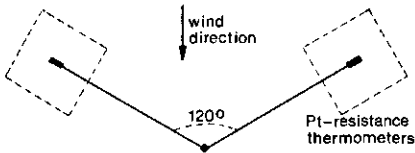

Fig. 15. Top view and orientation of Mast 13 in 1976.

1.00, 1.50, 2.00, 2.50 and 3.00 m. Mast 14 (1.5 m high) was used for measurement of net radiation. Heat flux in soil was measured at Site 15 (Fig. 14). Measurements were again centrally recorded in the Cabin a.

4.3 INSTRUMENTS AND RECORDING

In general, the measurements were recorded simultaneously over runs of 30 min. Between successive runs, a short break is necessary to reload paper tape and chart rolls. Thus in practice the runs were about 10 min apart. Some quantities (like net radiation, soil heat flux) were continuously recorded with a pen-recorder.

During each run, data were also noted on weather (like cloudiness), condition of the maize crop and condition of the soil surface.

As mentioned in Chapter 1 in this report main attention was given to the wind-profile measurements. Therefore the instruments used for the energy balance and the eddy-correlation method will be described only briefly in these sections.

4.3.1 Instruments used for the wind-profile method

Small rotating cup-anemometers designed at the Laboratory of Physics and Meteorology were used to measure wind velocity (Fig. 16). In 1974, the rotor of the anemometers was fitted with three hemispherical ping-pong ball cups. In the next year these cups were replaced by conical cups made of polyvinylchloride. These cups were less fragile and the conical shape produced a better linear relation between rotation and wind speed (Sheppard, 1940). Before the 1976 measurements, the plug connexion (Fig. 16, Item d) was removed and replaced by a wire connexion within the housing. The signal wire leaving the anemometer housing had a length of 0.5 m. At the other end of this wire, the plug connexion was mounted where a plug (Item f) was fitted to connect the wire to the signal cable and so to the counter device. As a result of this, the total height of the anemometer was substantially reduced (Photo 3).

The signal was generated by an opto isolator in the anemometer housing. This device consisted of a diode that emitted infrared radiation that was reflected by a small disk. The reflected radiation hit a photo-darlington that was connected to the signal wire. The small disk was mounted at the end of the rotor spindle and thus rotated with the cup assembly. A sector of the disk was painted black and interrupted reflection. So each revolution was converted into a single pulse from the photo-darlington.

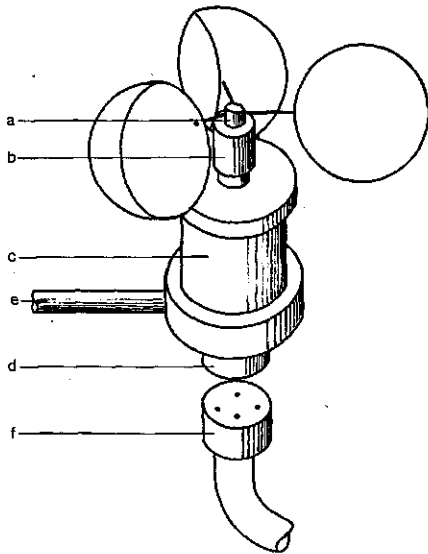

Fig. 16. Small rotating cup-anemometer. a = three-cup rotor, cup diameter 40 mm, arm length 20 mm; b = rotor spindle, length 25 mm; c = anemometer housing with inside a transmitter, diam. 32 mm, height 42 mm; d = plug connexion for the signal wire, height 12 mm; e = mounting bar, length 0.30 m; f = plug of signal wire; height of d and f totals 60 mm.

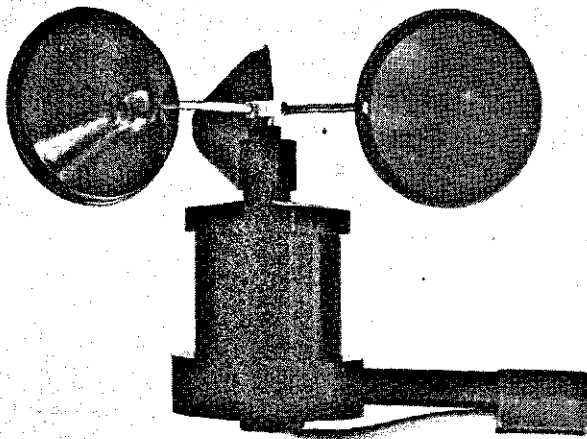

Photo 3. Cup-anemometer used in the 1976 experiment.

An electronic counter recorded the signals from five anemometers simultaneously. The pulses were counted over a run of 30 min and afterwards the total number from each anemometer was printed on a paper chart. The mean wind speed was calculated from the calibration equations of the anemometers.

4.3.1.1 Calibration of the cup-anemometers

The cup-anemometers were calibrated in the wind tunnel of the Laboratory of Physics and Meteorology. This open wind tunnel had a measuring chamber of 0.4 m x 0.4 m x 0.4 m. The range of velocities generated within the tunnel was 0.50 - 15.00 m/s. Flow was measured with a pitot tube, a Disa hot-wire anemometer and a laser-doppler velocimeter (Klaassen, 1976b). The accuracy of the absolute wind velocity in the tunnel amounts to about 1 to 2%. This may cause a systematic error in the calibration of the cup-anemometers. However in the present research, the accuracy of calibration and reliability of the cup-anemometers relative to one another played a more important role than the absolute accuracy. In other words, when the calibration error remains a systematic one, it does not harm the relative accuracy of the measurements in the present work. An influence of air pressure and temperature on calibration of the cup-anemometers was not noticeable. The anemometers were mounted in the tunnel in the same way as in the field. The anemometer was placed in the centre of the measuring chamber attached at the upwind side of a vertical mast. The cup-anemometers were calibrated for wind speeds prevailing in field conditions: 1.00 - 8.00 m/s. In this range the calibration curve of these anemometers is linear (Fig. 17) and can be represented by

$$\bar{u} = a n + b \quad (36)$$

where \bar{u} is the mean wind velocity and n the number of revolutions per unit of time; a and b are calibration constants. The starting speed of the conical cup-anemometers was estimated with slowly increasing wind velocity in the tunnel and averaged 0.53 m/s. The stalling speed determined in the same way with decreasing velocity was 0.24 m/s. These values have no important physical meaning, but provide some indication on starting and stalling speeds that may be expected in field experiments. The calibration curve could be reproduced with 1% accuracy. During the measuring season, the cup-anemometers were frequently recalibrated to check for deviations from the calibration curve.

Besides being calibrated and recalibrated in the wind tunnel, anemometers were calibrated in the field in relation to one another. The anemometers could be related to one another by matching (Tanner, 1963). This relative calibration took place above a pasture with a sufficient fetch over a uniform grass surface. This pasture was also at the Experimental Station of the Agricultural University, the Ir. A.P. Minderhoudhoeve. Eight anemometers were attached on top of eight separate masts (diam. 28 mm) 1.50 m above ground level. The masts were positioned in line and 1.50 m apart (Photo 4). The line of these masts was normal to direction of the prevailing wind. The anemometers were mounted upwind of the masts. The mean wind speed was measured over 6 runs of 10 min. Then the anemometers were interchanged to eliminate local effects. This relative calibration showed that all

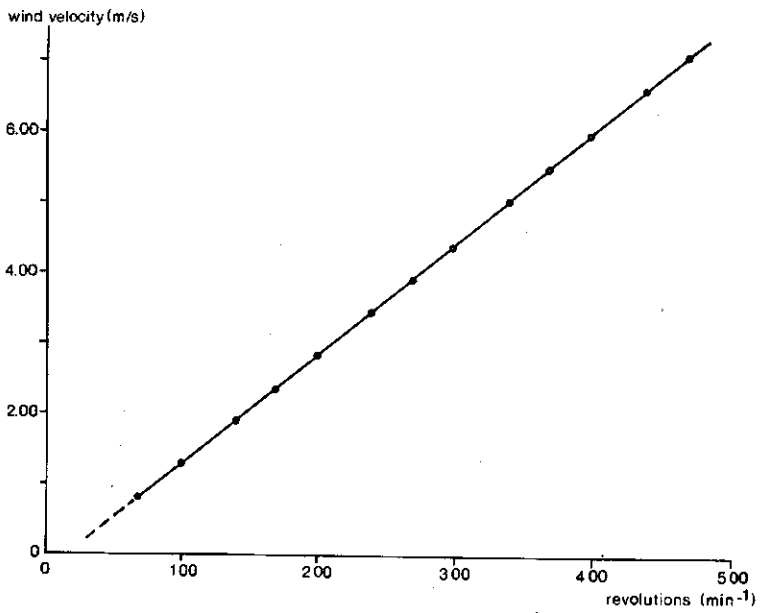

Fig. 17. Calibration curve of a cup-anemometer.

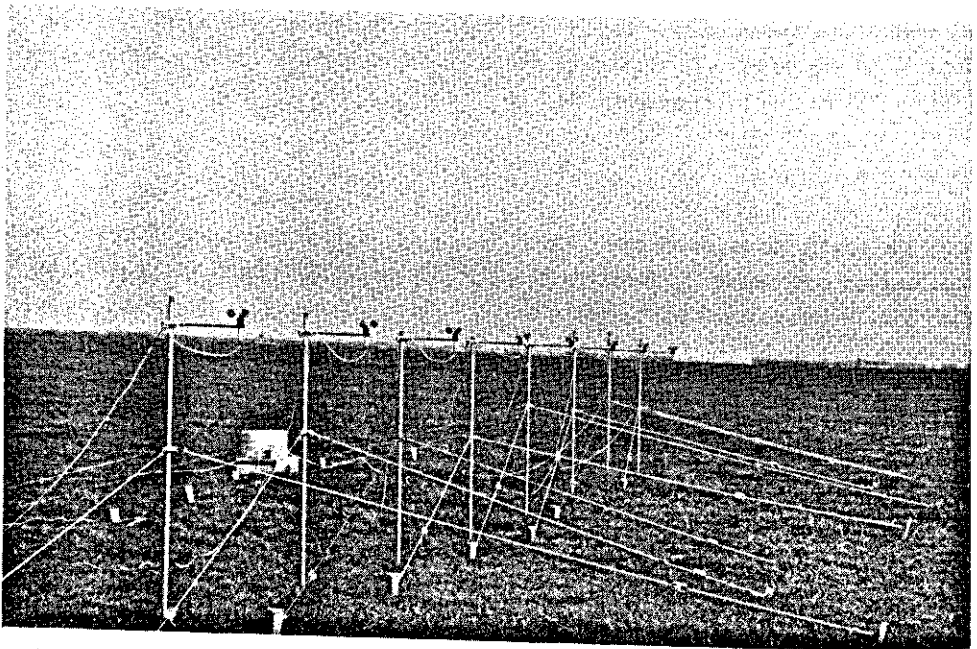

Photo 4. Relative calibration of cup-anemometers in the field.

(24) anemometers except three responded to a fluctuating wind speed in the same way. So strong indication was obtained that the relative wind-tunnel calibration was reliable for field experiments.

4.3.1.2 Overestimation of wind velocity

It is well known from the literature that wind velocity measured with cup-anemometers is affected by several errors (e.g. MacCready, 1966; Bernstein, 1967; Hyson, 1972). Cup-anemometers do not respond only to the horizontal wind component. MacCready (1966) found that small cup-anemometers recorded the total wind vector rather than the horizontal component, if the elevation angle of the total wind vector did not exceed 45° . Moreover in gusty winds, some cup-anemometers accelerate faster than they decelerate (Hyson, 1972). These phenomena lead to an overestimation of the actual horizontal wind velocity. Under ordinary conditions, this overestimation equals about 10% (Bernstein, 1967; Izumi & Barad, 1970), so that wind velocity measured with cup-anemometers should be reduced by about 10%.

In micrometeorology, however, this correction is seldom applied (Businger et al., 1971). In the present work, the results are derived from the measured data without correction, to permit easier comparison with results from other experiments. Moreover it is difficult to reduce the data in the correct way, as the correction factor depends on the properties of the cup-anemometers used in the experiment, atmospheric conditions and the height of measurement (MacCready, 1966). This aspect also hinders valid comparison between results from different authors. Nevertheless it is felt that comparison with uncorrected data from the literature is the least questionable approach.

4.3.2 Instruments used for the energy balance and eddy-correlation method

The temperature was measured with platinum-resistance thermometers. The measured time constant of these sensors is 35 s in a turbulent wind of speed 2 m/s (Stigter et al., 1976). It is easy to understand that for higher wind speeds the time constant decreases. For the present experimental conditions (wind speed no higher than 6 m/s), the time constant would vary from 35 s to about 25 s. The output of the sensors was recorded by a Modulog data-logging system, with a resolution of 1 μ V, in the Cabin a (Fig. 10, 12 and 14). For practical reasons the pre-amplifier and scanner of this system were situated in the field.

The air humidity sensors were differential thermocouple psychrometers designed at the Laboratory of Physics and Meteorology. The time constant was calculated to be about 0.5 s (Stigter & Welgraven, 1976). The humidity sensors were also connected to the Modulog system.

Net radiation above the maize crop and the grass surface was measured with Funk-type polythene-shielded net radiometers. Net radiation was recorded on chart by a continuous pen-recorder (Sefram low impedance recorder).

Heat flux in soil was measured by several methods. It was recorded directly with heat-flux plates developed by the Delft Institute of Applied Physics TNO-IH, while simultaneously a set of thermocouples and a number of platinum-resistance thermometers were

placed at different depths in the soil (Voortman, 1976). Also the thermal conductivity of soil was estimated by the non-stationary line-source method. The output was recorded by high-impedance flat-back pen-recorders (Kipp, Delft; Goerz, Vienna).

For eddy-correlation measurements, sensitive instruments with fast response are required in order to record accurately the rapid fluctuations in wind velocity and temperature. In 1976, three distinct sensors were used: a vertical Gill propeller system, a Gill propeller bivane and a hot cross-wire anemometer system. The output from the correlation instruments was recorded on line by a PDP8 minicomputer in the cabin that also simultaneously calculated several quantities like heat flux and shear stress. For details about the measurements and results of the eddy-correlation method, see Ruijschoot (1976), Klaassen (1976a), Van Costerum (1977) and Bottemanne (1977a, b).

Wind direction was measured by a high accuracy potentiometric wind vane and recorded with a flat-back pen-recorder.

5 Fetch and height of measurement

5.1 ESTIMATE OF THE ACTUAL FETCH

The fetch determines the height of the adapted layer and so the maximum height of measurement (Sect. 3.2). Therefore attention was first paid to the actual fetch over the experimental field during the measurements. The fetch was defined as the distance between the mast and nearest upwind edge of the maize field. From the measurements a reasonable estimate of the ratio of the height of the adapted layer to fetch may be deduced.

At the site of measurement, the fetch depends closely on the wind direction (Sect. 4.2.1). The Figures 18 and 19, for instance, show the dependence of fetch on wind direction for Masts 1 and 3 in the arrangement of 1975, respectively. Figure 18 shows that the fetch could decrease considerably with only a small change in wind direction.

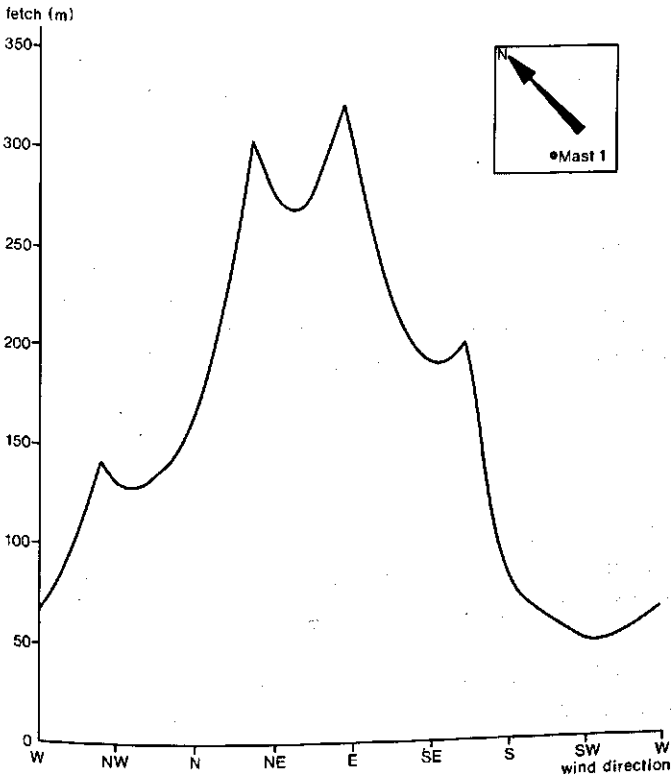

Fig. 18. Dependence of the fetch on wind direction (Mast 1, 1975) and situation of Mast 1 in the maize field.

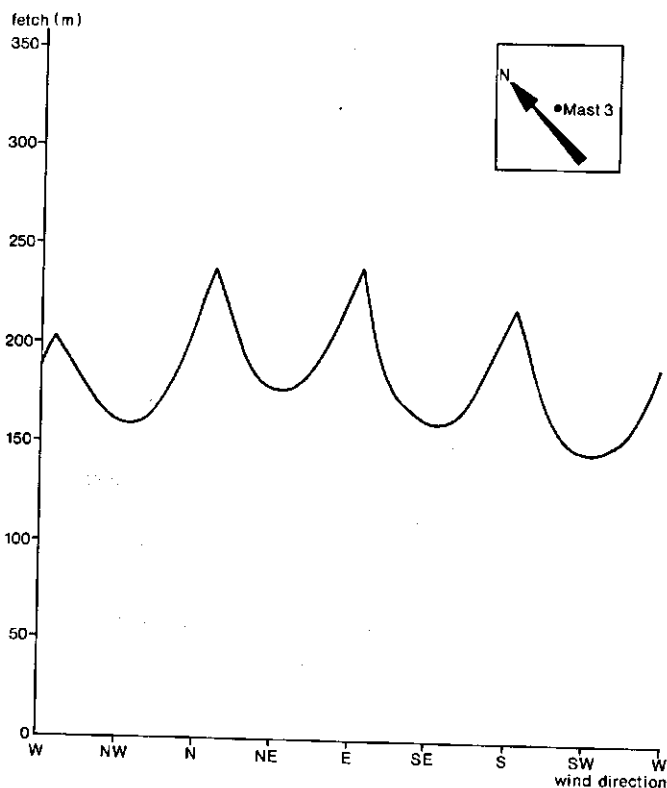

Fig. 19. Dependence of the fetch on wind direction (Mast 3, 1975) and situation of Mast 3 in the maize field.

For every run, the extremes of wind direction during that run were read from the paper chart of wind direction. With these data, the maximum and minimum fetch together with the prevailing fetch were obtained from the fetch-wind direction plots for each mast. Especially the prevailing fetch played an important role in the measurements as it determines the height up to which on the average measurements may be accepted to determine the logarithmic wind profile.

5.2 INFLUENCE OF FETCH ON THE WIND PROFILE

To examine the validity of the logarithmic wind profile and the influence of the fetch on the wind profile all wind data of the 1975 program were plotted against $\ln z$ and against $\ln(z - d)$, where d is the best fitting value of the zero-plane displacement (Chap. 6). These plots often showed a kink in the experimental wind profile (Fig. 20; Sect. 3.2), in contradiction to the assumed logarithmic curve. The pertinent points of measurement that deviate from the theoretical picture could not be fitted to the theoretical curve of \bar{u} against $\ln(z - d)$ by better adjustment of the zero-plane displacement. Also instrumental errors could not be responsible for the systematic deviations that occurred mainly in the profiles measured at Mast 3 but also sometimes in the profiles at Mast 1 (1975).

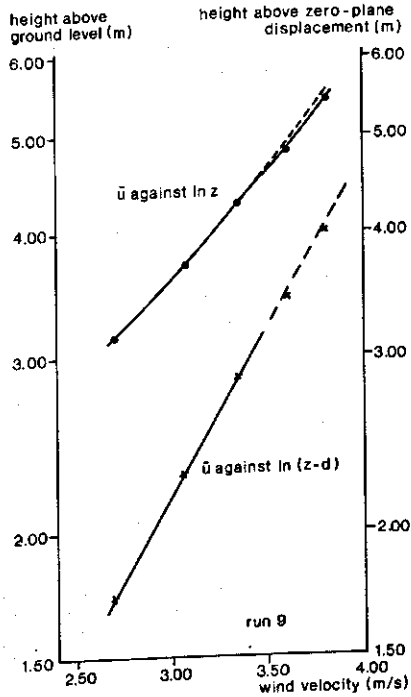
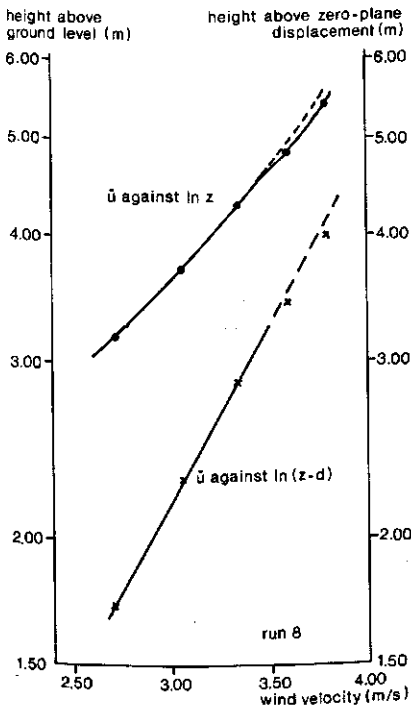
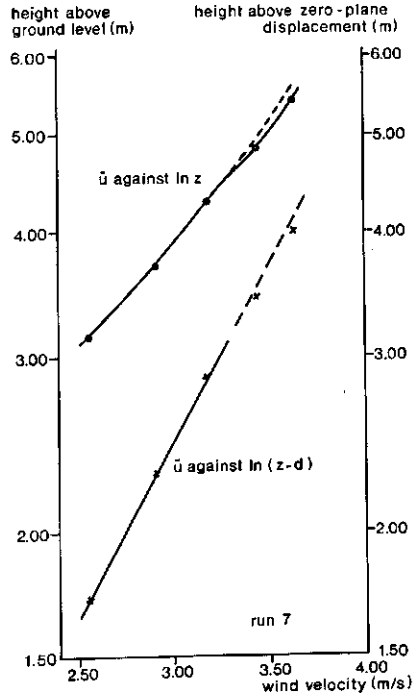
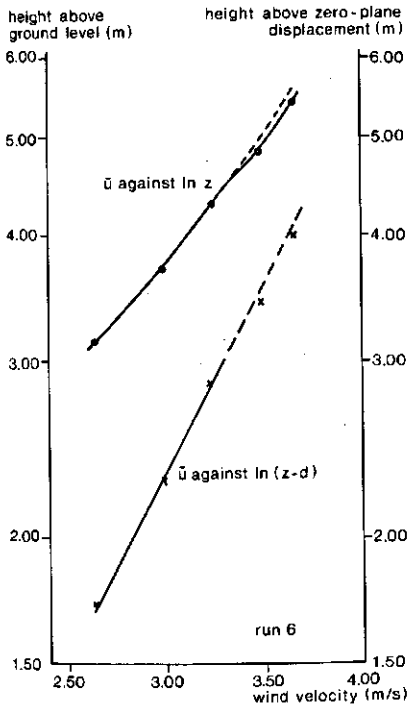

Fig. 20. Systematic deviations from the logarithmic curve. Plots of \bar{u} against $\ln z$ and \bar{u} against $\ln(z-d)$. Measurements 1975-08-26, Mast 3, $d = 1.42$ m.

So the influence of an insufficient fetch had to be investigated as a possible reason for this discrepancy. Figure 21 illustrates the relationship between the prevailing fetch and the occurrence of the kink in the wind profile: in the 1975 arrangement with a north-easterly wind, Masts 1, 3 and 4 had fetches decreasing in that order. Figure 21 illustrates that the results from Mast 1 fit the theoretical curve reasonably well. At Mast 3, on the contrary, the upper data points deviate from the logarithmic curve drawn through the points of measurement at lower levels. When these deviating data were ignored and the same fixed zero-plane displacement d was assumed for both masts, the same values of u_* and z_0 were found from the measurements at Mast 1 and Mast 3. If these values of d and u_* were assumed to be valid also for the wind profile at Mast 4, the upper points of measurement of this mast deviated strongly from the logarithmic curve drawn through the lowest data point. Figure 21 shows that for Mast 4 this assumed wind profile does not hold, even for the lowest region of measurement.

The above considerations are still confirmed by comparison of the wind velocities measured at the lowest height of Masts 1, 3 and 4 (Table 4). This comparison shows that the discrepancy notably occurs in the wind velocity measurements that corresponded with a small fetch (Fig. 21, Mast 4); with a large fetch, the measured wind velocities were nearly equal.

5.3 DEPENDENCE OF THE HEIGHT OF THE ADAPTED LAYER ON WIND VELOCITY

For every run, those heights of measurement are supposed to be within the adapted layer that are situated lower than the kink in the wind profile. Data about fetch, wind velocity and number of heights of measurement within the adapted layer are listed in Table 5. The runs are arranged in classes of increasing fetch and within each class the wind velocity increases.

Table 4. Range of fetch, prevailing fetch and wind velocity of some measurements at Masts 1, 3 and 4 in 1975. The wind velocity was taken at the lowest height of measurement. With a large fetch, the measured wind velocities were nearly equal.

Mast 1			Mast 3			Mast 4		
range of fetch (m)	prev. fetch (m)	wind vel. (m/s)	range of fetch (m)	prev. fetch (m)	wind vel. (m/s)	range of fetch (m)	prev. fetch (m)	wind vel. (m/s)
215 - 325	240	1.82	175 - 325	180	1.83	50 - 105	50	2.08
170 - 300	260	2.18	175 - 225	180	2.11	50 - 80	50	2.35
270 - 300	270	2.19	175 - 200	175	2.10	50 - 55	50	2.45
270 - 300	270	2.15	175 - 200	175	2.13	50 - 55	50	2.41
270 - 300	270	2.17	175 - 200	175	2.10	50 - 55	50	2.31
270 - 325	270	1.82	175 - 225	180	1.75	50 - 65	50	2.09
190 - 295	200	2.30	160 - 235	170	2.29	65 - 170	80	2.43
190 - 295	200	2.34	160 - 235	170	2.35	65 - 170	80	2.43
135 - 300	180	1.77	160 - 235	180	1.77	50 - 170	50	1.88
130 - 135	130	2.55	160 - 165	160	2.64	160 - 170	160	2.63

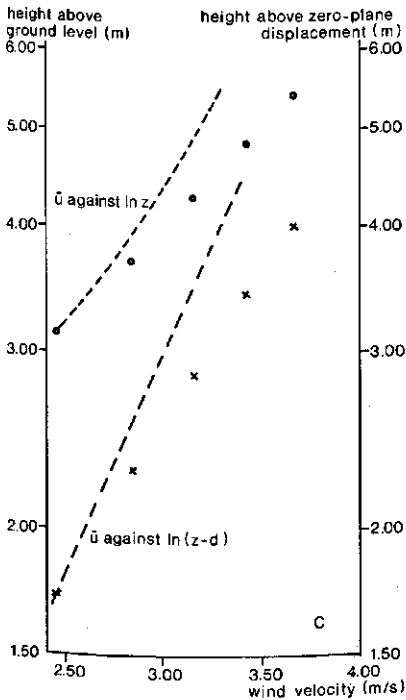
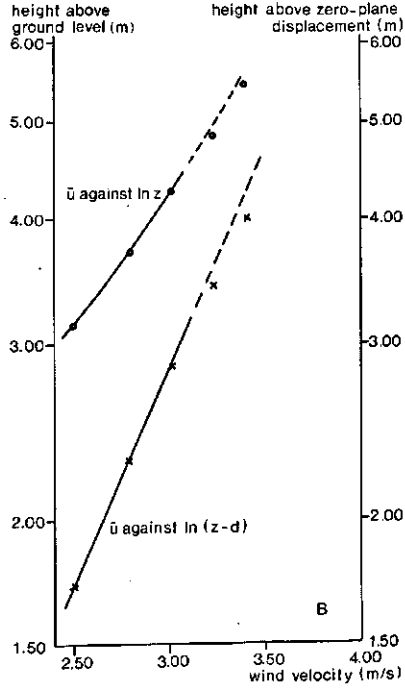
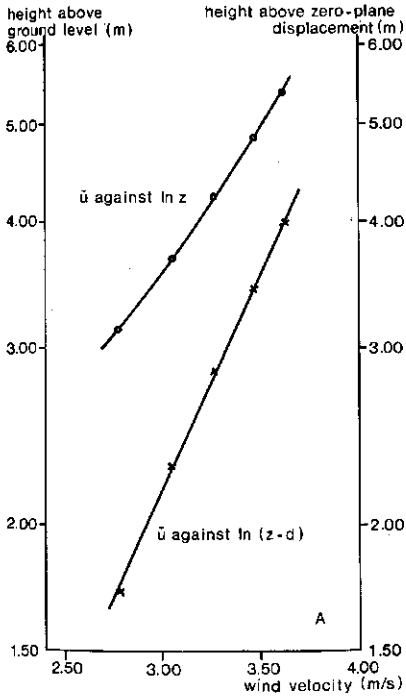

Fig. 21. Wind-profile measurements with a decreasing fetch (Run 7, 1975-08-27).

- | | |
|--|--|
| <p>A. Mast 1
 $d = 1.42$ m
 $u_* = 0.398$ m/s
 $z_0 = 0.193$ m
 fetch 270 - 300 m
 prevailing fetch 270 m</p> | <p>B. Mast 3
 $d = 1.42$ m
 $u_* = 0.393$ m/s
 $z_0 = 0.202$ m
 fetch 175 - 200 m
 prevailing fetch 175 m</p> |
| <p>C. Mast 4
 $d = 1.42$ m
 $u_* = 0.390$ m/s
 $z_0 = 0.138$ m
 fetch 50 - 55 m
 prevailing fetch 50 m</p> | |

Table 5 shows that with a small fetch sometimes five heights of measurement could be used to estimate \bar{d} , z_0 and u_* when the mean wind velocity was less than about 3 m/s. With a larger wind velocity, the number of usable heights decreases. This indicates that the height of the adapted layer decreases when the wind velocity increases. This is a general phenomenon of boundary layers. For the surface boundary layer in meteorology, Echols & Wagner (1972) observed, in their wind-profile measurements near a coast line, also that the height of the adapted layer decreased when the wind velocity increased.

Table 5 shows also that, with a larger fetch, five heights of measurement could be used also when the wind velocity was larger than 3 m/s. This illustrates that the height of the adapted layer increases with an increasing fetch.

5.4 ESTIMATE OF THE HEIGHT-TO-FETCH RATIO

The validity for the present research of the generally adopted ratio between the thickness of the adapted layer and the fetch, $\delta(x)/x = 1/100$, was checked against the measurements. For that purpose, measured wind profiles with a kink as well as those that fitted the logarithmic wind profile were used.

To estimate the height of the adapted layer, the zero-plane displacement should be known, because the adapted layer is assumed to be developing above this fictitious zero-plane (Munro & Oke, 1975). If the zero-plane displacement cannot be neglected, $\delta(x)$ indicates the *thickness* of the adapted layer. So the *height* of the adapted layer $\delta'(x)$ is estimated with reference to *ground level*; the *thickness* of the adapted layer $\delta(x)$ is expressed with reference to *zero-plane level*. For a preliminary estimate of the thickness of the adapted layer, a fixed zero-plane displacement was used (Sect. 6.4, $d = 0.55 h$).

For a first approach only those measurements were selected that showed a logarithmic wind profile, without a kink. The data, for instance, on fetch and crop height for the days on which the majority of the measurements fitted this logarithmic profile are listed in Table 6.

Table 7 shows the calculated *height* of the adapted layer $\delta'(x)$ above ground level for these measurements. This calculation assumed (1) the thickness of the adapted layer $\delta(x)$ was 0.01 times the prevailing fetch and (2) the zero-plane displacement was 0.55 times the crop height. The sum of these quantities would indicate the maximum height of measurement. From a comparison between this calculated height (Table 7) and the greatest height actually used in the experiment (Table 6), it is clear that this latter height should lie above the adapted layer. The measured profiles, however, being correctly logarithmic, showed that the greatest height was still within the adapted layer. This suggests that Assumptions 1 and 2 might be too cautious. So the validity of these assumptions in the present research must be reexamined.

To tackle this problem in a first approach, the ratio $\delta(x)/x$ is maintained at 1/100, but the zero-plane displacement may differ from $d = 0.55 h$. The total height of the zero-plane displacement added to the thickness of the adapted layer should equal at least the greatest height of measurement. If so, the zero-plane displacement should have a certain minimum for every run. These minima are collected in Table 8. The table shows, however, that in this approach, d frequently exceeds crop height. From a physical viewpoint, this

Table 5. Fetch, wind velocity and number of heights of measurement in the adapted layer. Measurements in 1975 and 1976 at Masts 1, 2 and 3 on different levels above ground.

	Range of fetch (m)	Wind velocity (m/s)	Number of hts in the adapted layer		Range of fetch (m)	Wind velocity (m/s)	Number of hts in the adapted layer
A. 1975, 4.15 m above ground							
Mast 1	190 - 325	2.08	4	215 - 295	3.52	3	
		3.16	3		3.74	3	
	215 - 325	2.92	3	190 - 325	2.36	5	
		3.00	3		2.73	5	
		3.34	3		215 - 325	2.24	5
		3.35	3			2.29	5
		3.40	3			2.34	5
	265 - 300	3.60	3		2.36	3	
		2.34	3		2.43	5	
		2.47	5		2.69	3	
		2.59	3		2.82	3	
		2.62	5		3.00	3	
		2.63	5		3.15	3	
		2.66	5	265 - 300	2.22	3	
		2.67	5		2.50	3	
		2.68	5	270 - 300	2.61	5	
		2.86	5		2.72	5	
		2.90	5		2.75	5	
		2.92	3		2.75	5	
		2.96	5	270 - 325	2.04	4	
2.97	5	2.28	3				
	3.05	3		2.28	4		
	3.06	3		2.29	5		
	3.40	5		2.43	5		
Mast 3	175 - 200	2.38	3		2.46	5	
		2.43	3		2.53	4	
		2.98	3		2.77	4	
		2.58	3		2.64	3	
		2.60	3		2.69	4	
	160 - 235	2.98	3		2.77	4	
		3.02	3	Mast 3 175 - 200	2.69	3	
		3.05	3		2.73	3	
		2.11	3		2.74	3	
		175 - 225	3.10	3	160 - 235	2.28	5
	2.63		3	2.59		3	
	2.66		3		2.74	3	
	2.74		3		2.93	3	
	2.75		3		2.96	4	
	2.83		3		3.04	3	
2.84	3			3.13	4		
2.95	3		175 - 225	1.93	5		
2.97	3			2.29	3		
180 - 235	3.32		3		2.33	3	
	2.82	3		2.47	5		
	3.12	3		2.76	3		
	3.29	5	180 - 235	2.21	3		
	3.39	3		2.27	5		
	3.40	3		2.27	4		
	3.57	3		2.28	3		
				2.38	3		
			2.74	4			
B. 1975, 4.45 m above ground							
Mast 1	190 - 295	2.66	3		2.93	3	
		2.83	3		2.96	3	
		2.89	3		3.03	3	
		2.91	3		3.31	3	
		2.93	3		3.73	3	
		3.27	3				

Table 5. continued.

	Range of fetch (m)	Wind velocity (m/s)	Number of hts in the adapted layer	Range of fetch (m)	Wind velocity (m/s)	Number of hts in the adapted layer
C. 1976, 3.60 m above ground						
Mast 1	90 - 320	2.55	5	140 - 320	3.50	4
		2.70	5		3.63	3
		2.81	5		3.67	4
		2.83	3		3.69	3
	160 - 320	2.64	3	180 - 340	2.70	5
		2.81	3		2.78	4
		2.88	5		2.80	3
		3.12	5		2.91	5
		3.26	5		3.19	5
		3.40	4		3.26	3
		3.50	3		3.42	3
		3.52	3		3.48	4
		3.55	3		3.50	4
		3.60	3		3.54	3
		3.61	5		3.57	3
		3.62	5		3.60	3
		3.64	5		3.64	4
		3.82	3		3.80	3
		3.92	5		3.86	3
		3.97	3		3.87	4
		4.00	5		4.00	4
		4.19	4		4.11	4
		4.47	4		4.17	4
		4.48	3		4.52	3
	200 - 320	2.92	5		4.68	3
		3.41	3	200 - 320	3.28	4
		3.92	5		3.58	3
	180 - 330	2.04	3		3.84	3
		2.10	5		4.07	3
		2.25	5	250 - 340	3.83	3
		2.54	4			
		2.81	5			
		2.82	5			
		3.10	3			
		3.17	3			
		3.19	4			
		3.43	4			
		3.48	4			
		3.59	3			
		3.64	3			
		3.73	3			
	260 - 330	3.32	5			
		3.41	5			
		3.45	5			
		3.80	3			
Mast 2	80 - 340	2.62	4			
		2.65	3			
		2.71	3			
		2.92	5			
	140 - 320	2.50	3			
		2.84	4			
		2.93	3			
		3.03	4			
		3.15	3			
		3.20	3			
		3.21	3			
		3.26	3			
		3.48	3			

Table 6. Data of measurements fitting the logarithmic wind profile.

Date	Mast	Number of runs	Crop height (m)	Upper ht of measurement (m)	Range of fetch (m)	Prevailing fetch (m)
1975-08-19	4	9	2.60	5.42	200 - 310	270
1975-08-27	1	7	2.60	5.42	270 - 300	270
1975-09-02	1	5	2.60	5.42	270 - 325	270
1976-08-14	1	8	2.10	4.30	260 - 330	280
1976-08-16	1	6	2.10	4.30	180 - 330	280
1976-08-20	2	3	2.10	4.30	180 - 340	200
1976-08-23	1	6	2.10	4.30	90 - 240	170
1976-08-26	1	3	2.10	4.30	160 - 320	160
1976-08-26	2	4	2.10	4.30	180 - 340	200

Table 7. Calculation of the height of the adapted layer above ground $\delta'(x)$ with $\delta(x)/x = 1/100$ and $d = 0.55 \bar{h}$.

Date	Mast	Number of runs	$x/100 + 0.55 \bar{h}$ (m)	$\delta'(x)$ (m)	
1975-08-19	4	9	2.70	1.43	4.13
1975-08-27	1	7	2.70	1.43	4.13
1975-09-02	1	5	2.70	1.43	4.13
1976-08-14	1	8	2.80	1.16	3.96
1976-08-16	1	6	2.80	1.16	3.96
1976-08-20	2	3	2.00	1.16	3.16
1976-08-23	1	6	1.70	1.16	2.86
1976-08-26	1	3	1.60	1.16	2.76
1976-08-26	2	4	2.00	1.16	3.16

Table 8. Calculation of the zero-plane displacement d with the assumption $\delta(x)/x = 1/100$.

Date	Mast	Number of runs	Upper height of measurement (m)	$x/100 = d_{\min}$ (m)	
1975-08-19	4	9	5.42	2.70	2.72
1975-08-27	1	7	5.42	2.70	2.72
1975-09-02	1	5	5.42	2.70	2.72
1976-08-14	1	8	4.30	2.80	1.50
1976-08-16	1	6	4.30	2.80	1.50
1976-08-20	2	3	4.30	2.00	2.30
1976-08-23	1	6	4.30	1.70	2.60
1976-08-26	1	3	4.30	1.60	2.70
1976-08-26	2	4	4.30	2.00	2.30

is unlikely (Sect. 2.1.1) and so it must be concluded that, alternatively, the thickness of the adapted layer can be assumed to be larger than the value calculated with $\delta(x)/x = 1/100$.

Consequently in a second approach, the thickness of the adapted layer was estimated with the assumption that it extended to the greatest height of measurement and that d was invariably equal to $0.55 h$. Table 9 shows calculated thicknesses of the adapted layer and the ratio $\delta(x)/x$ obtained from this thickness and the actual fetch. The average ratio equals $1/66$. This is a *minimum ratio*, because for the calculation the greatest height of measurement was assumed to be the upper limit of the adapted layer too. However the adapted layer may extend to a still higher level, and, if so, the ratio should have a larger value.

To obtain a *maximum ratio* $\delta(x)/x$ the measurements which showed a kink in the wind profile are taken into consideration. The greatest height of measurement that still fitted the logarithmic curve was assumed to correspond to the maximum height of the adapted layer (Table 10). The average of these maxima leads to a maximum $\delta(x)/x$ of $1/61$. To appreciate

Table 9. Thickness of the adapted layer $\delta(x)$ and minimum ratio $\delta(x)/x$. Mean minimum ratio $[\delta(x)/x]_{\min.} = 1/66$.

Date	Mast	Number of runs	Upper height of measurement - d (m)	$\delta(x)$ (m)	x (m)	$[\delta(x)/x]_{\min.}$	
1975-08-19	4	9	5.42	1.43	3.99	270	1/67.7
1975-08-27	1	7	5.42	1.43	3.99	270	1/67.7
1975-09-02	1	5	5.42	1.43	3.99	270	1/67.7
1976-08-14	1	8	4.30	1.16	3.14	280	1/89.2
1976-08-16	1	6	4.30	1.16	3.14	280	1/89.2
1976-08-20	2	3	4.30	1.16	3.14	200	1/63.7
1976-08-23	1	6	4.30	1.16	3.14	170	1/54.1
1976-08-26	1	3	4.30	1.16	3.14	160	1/51.0
1976-08-26	2	4	4.30	1.16	3.14	200	1/63.7

Table 10. Thickness of the adapted layer $\delta(x)$ and maximum ratio $\delta(x)/x$, obtained from wind-profile measurements with a kink in the wind profile. Mean maximum ratio $[\delta(x)/x]_{\max.} = 1/61$.

Date	Mast	Number of runs	Upper ht of measurement - d (m)	$\delta(x)$ (m)	x (m)	$[\delta(x)/x]_{\max.}$	
1975-08-19	3	8	4.28	1.43	2.85	160	1/56.1
1975-08-27	3	6	4.28	1.43	2.85	180	1/63.2
1975-08-28	1	9	4.85	1.43	3.42	220	1/64.3
1975-08-28	3	7	4.28	1.43	2.85	180	1/63.2
1976-08-14	2	7	4.00	1.16	2.84	220	1/77.5
1976-08-16	2	6	4.00	1.16	2.84	200	1/70.4
1976-08-20	1	8	4.00	1.16	2.84	160	1/56.3
1976-08-23	2	6	4.00	1.16	2.84	140	1/49.3

the significance of this result, one must remember however, that the least height at which the wind profile starts to deviate from the logarithmic model cannot be observed precisely since only a few heights of measurement were available. Nevertheless a fair indication for the maximum ratio may be obtained from this procedure.

From all these considerations, as a liberal estimate for the present experiment, $\delta(x)/x$ was taken equal to $1/64$. According to Munro & Oke (1975), such a value could be expected where large changes in surface roughness are involved.

In this experiment, the measurements were taken in a neutral or near-neutral atmosphere with a moderate wind velocity of 2 - 6 m/s. So instability and wind velocity would not have noticeably influenced the thickness of the adapted layer. Under unstable conditions, however, the thickness of the adapted layer would increase and the ratio $\delta(x)/x$ of $1/64$ should be a safe estimate.

For the estimation of the ratio $\delta(x)/x$ the dependence of the thickness of the adapted layer on small deviations from the daily mean wind velocity was not taken into account. Although there was a slight dependence (Sect. 5.3), this will not noticeably influence the mean ratio $\delta(x)/x = 1/64$, because for the estimation of $\delta(x)/x$ a mean fetch and a mean estimate of the height of the adapted layer for each day of measurement was used. Of course no conclusion can be drawn, from the present work, for wind velocities larger than 6 m/s.

5.5 MEASURING LAYER

Although the actual thickness of the adapted layer in this experiment was larger than the usual rule of thumb would suggest, the adapted layer was seldom developed to a height sufficient for workable and successful profile measurements. In practice, the fetch has been reduced for several reasons. As mentioned in Sections 4.2.1 and 5.1, actual fetch would be less than total field length and could decrease sharply with a small change in wind direction.

Moreover for a tall crop, part of the adapted layer was enclosed by the vegetation. Therefore the thickness of the layer actually available for profile measurements could differ considerably from the thickness of the adapted layer. For convenience, the part of the adapted layer actually available for profile measurements will be called the *measuring layer*.

To illustrate this point, in the following example (Fig. 22) the thickness of the measuring layer was estimated. For a crop height h of 2.60 m, the zero-plane displacement was assumed to be 1.40 m, the fetch 240 m and the ratio $\delta(x)/x$ $1/60$. The thickness of the adapted layer $\delta(x)$ was $(240/60) \text{ m} = 4.00 \text{ m}$ and the maximum height of measurement above ground level was $4.00 \text{ m} + 1.40 \text{ m} = 5.40 \text{ m}$. Figure 22 shows that the thickness of the measuring layer, then was $5.40 \text{ m} - 2.60 \text{ m} = 2.80 \text{ m}$, instead of 4.00 m. In this example, the thickness of the measuring layer would be reduced even more, because also a certain minimum height from the top of the crop to the lowest sensor has to be taken into account (Sect. 3.4).

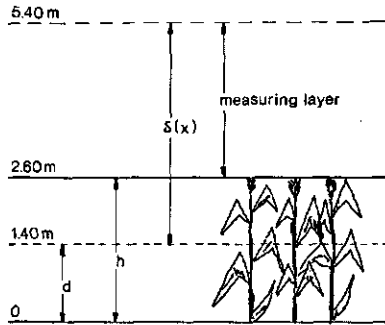

Fig. 22. Part of the adapted layer suitable for measurements: measuring layer. d = zero-plane displacement; h = crop height; $\delta(x)$ = adapted layer.

6 Zero-plane displacement and roughness length

6.1 ESTIMATION OF ZERO-PLANE DISPLACEMENT AND ROUGHNESS LENGTH

Some methods of estimating d , u_* and z_0 from wind-profile measurements were set out in Section 2.2. The graphical method and the regression analysis by the method of least squares have often been used in the literature. These methods were also applied in the present experiment, but they were not successful. So in this experiment, d , u_* and z_0 had to be estimated in a different way. Ultimately they were estimated from a comparison with the results of simultaneous eddy-correlation measurements.

6.2 DATA SELECTION

To estimate d , u_* and z_0 from the wind-profile data, only those measurements were chosen that were taken on days with almost ideal weather and for which also data were available from the eddy-correlation method. Only for those measuring days could the final results of both methods be compared later. Simultaneous measurements were taken in 1975 on 13, 14, 27 and 28 August and in 1976 on 14, 15, 19, 20 and 26 August.

For every run, the measured wind velocity was plotted on semi-logarithmic paper against the height above ground level. These curves serve to select heights of measurement suitable for estimation of d , u_* and z_0 . If a sufficient fetch is assumed, the height of the kink fixes the upper boundary of the adapted layer (when no kink is observed all heights of measurement may be supposed to lie within the adapted layer). All heights of measurement thus found to be within the adapted layer may be used for estimation of d , u_* and z_0 (Sect. 5.2).

From the 1976 experiments, the graphic plots sometimes looked like wind profiles measured in a stable atmosphere (Fig. 23). However in view of the actual weather, a stable atmosphere over the period during which most of the measurements were taken (from about 10.00 h to 16.00 h) was unlikely. This deceptively stable appearance of the profiles may result from the uppermost point of measurement being above the adapted layer. If so, this uppermost point deviates from the smooth curve through the lower points of measurement. These deviating points are rejected in the elaboration of these runs.

6.2.1 The graphical method

The plots of \bar{u} against $\ln z$ showed that the thickness of the adapted layer was often less than expected when the measuring equipment was set up. Consequently fewer heights of measurement were within that layer than expected. So d , u_* and z_0 were to be estimated from a profile with only 3 or 4 points of measurement instead of 5.

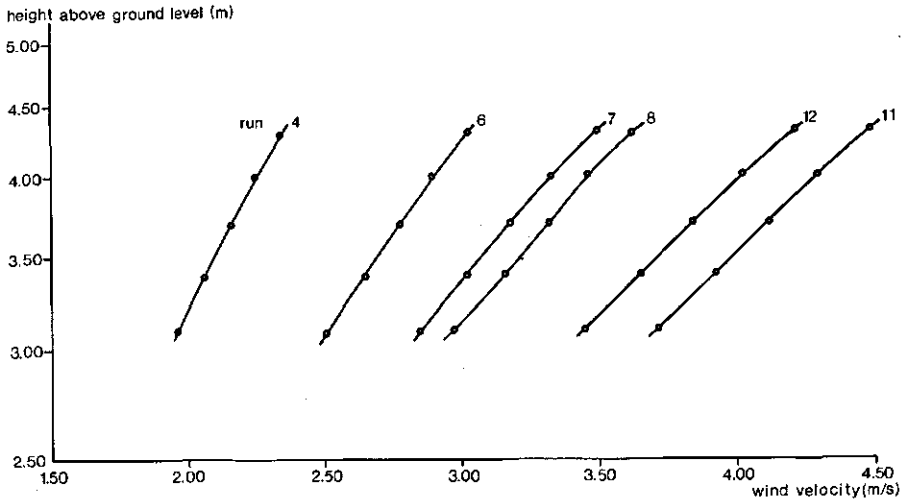

Fig. 23. Deviation of the uppermost point of measurement from the assumed logarithmic wind profile (1976-08-18, Mast 2).

In the present experiment, it proved impossible to estimate d graphically with an acceptable accuracy, i.e. variation about 10%. The parts of the plotted curves within the adapted layer often remained linear for a large range of d . Especially for the 1976 experiments with a smaller difference in height between the anemometers, a straight line could mostly be drawn through the points of measurement within about 1% error of measurement, even when d equals zero or exceeds crop height. One could expect improvement if the number of heights of measurement within the adapted layer increased. For that purpose, the difference in height between the sensors was reduced, but of course the total range of the profile did not increase. Therefore the curvature of the plot \bar{u} against $\ln z$ was still too small for estimation of d and z_0 , and consequently a workable estimate of u_* in this way was impossible.

6.2.2 Regression analysis by the method of least squares

Regression analysis was based on the principle that the plot \bar{u} against $\ln(z - d)$ is a straight line (Sect. 2.2.2). The method is set out in detail in Appendix 1.

The advantage is that this method is less time-consuming than the graphical method. Because the straightforward mathematical procedure, however, errors or discrepancies in the measurements could not easily be detected with this method. So it is difficult to interpret the results. To meet this disadvantage in this experiment, before all, the plots of \bar{u} against $\ln z$ were investigated first to eliminate errors of measurement and heights of measurement outside the adapted layer.

If 5 heights of measurement were used and the chance of deviations caused by a small fetch was not allowed for, the estimates of the zero-plane displacement ranged from -4.00 m to +2.50 m for a crop height of about 2.10 m (1976). If only the heights of measurement lying within the adapted layer were used, the estimate of d also varied considera-

bly and for a few runs d could not be estimated even with 20 iterations (App. 3). Here difficulties arose similar to those in Section 6.2.1 for the graphical method. When the difference in height of measurement was small and only a few heights of measurement were available, errors of measurement play an important role in this method. For instance a deviation of 1% in some of the measured wind velocities would cause a deviation already of about 5 cm in the zero-plane displacement. Just as for the graphical method, d , z_0 and u_* could not be estimated with the desired inaccuracy, for d for instance 10%.

6.2.3 Modified method of least squares

Sections 6.2.1 and 6.2.2 showed that d , u_* and z_0 could not be estimated from the present measurements by one of the generally used methods. A large range of d and z_0 resulted from use of either the graphical method or the method of least squares.

So a new approach was needed. Crucial point for the new approach suggested in this section is, that the zero-plane displacement is not solved from the experimental data but introduced in advance as a fixed value.

From a physical point of view, it is difficult to conceive how a zero-plane displacement larger than crop height or a negative zero-plane displacement could occur. So the value of d was chosen a priori within these limits. If d has been chosen, only two quantities remain unknown. So the method of least squares was employed again. The equations modified according to this new approach are listed in Appendix 4.

Extra requirements imposed on z_0 and \bar{u} are:

1. The roughness length z_0 should be about 0.06 - 0.13 times crop height. This estimate is based on values in the literature (Szeicz et al., 1969; Maki, 1975).
2. For each height of measurement used for the estimation of the parameters, it should hold that $|\bar{u}_{i,\text{calc}} - \bar{u}_{i,\text{meas}}| < 1\%$. This means that the measured wind velocity $\bar{u}_{i,\text{meas}}$ may not differ more than 1% from the wind velocity $\bar{u}_{i,\text{calc}}$ calculated from Equation 13 with the fixed d and the estimated u_* and z_0 .

A number of values of d , starting from zero and increasing in steps of 0.05 m was successively introduced into the equations. For each value of d the quantities u_* and z_0 were estimated. It appeared that a close correlation exists between d , u_* and z_0 estimated in this way (Fig. 24 and 25). If one of the two requirements mentioned before were not met, the introduced value of d was rejected. Even with these restrictions a large range of values still satisfied the logarithmic profile. For one and the same run of the 1975 measurements, d ranged from 1.30 m to 1.80 m and for the 1976 measurements from 0.90 m to 1.50 m. This variation is still too large for an acceptable estimate of the transport of momentum from these profile measurements. This is the reason why an effort is made to obtain a more reliable estimate of d from a comparison of eddy-correlation measurements and wind-profile measurements.

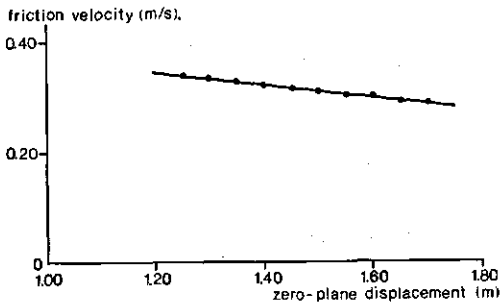

Fig. 24. Interdependence of friction velocity u_* and zero-plane displacement d estimated by the method of least squares (Run 1a, 1975-08-14).

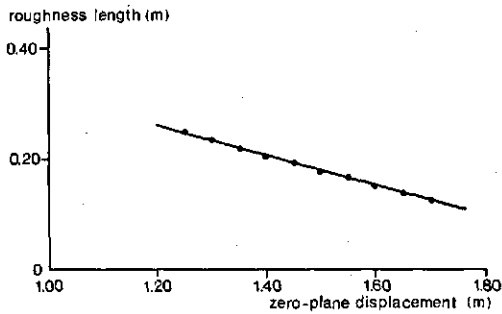

Fig. 25. Interdependence of roughness length z_0 and zero-plane displacement d estimated by the method of least squares (Run 1a, 1975-08-14).

6.2.4 Estimate of d and z_0 from simultaneous wind-profile measurements and eddy-correlation measurements

In Section 6.2.3, the profile method with the modified method of least squares led to an estimate of u_* and z_0 starting from a previously postulated value of d . However it was hardly possible to decide which of the successively postulated values of d was the best one. In Section 2.3, the eddy-correlation method was introduced, where u_* was estimated directly from the turbulent fluctuations. If u_* and \bar{u} be known, it must be possible to derive d and z_0 (Eq. 13). So two independent methods of finding d are available and simultaneous application could lead to a more precise result. This more precise d is used again to calculate u_* and z_0 by the method mentioned in Section 6.2.3.

In Section 2.3.2, a coefficient c was introduced, that can be written for the profile method as

$$c_p = u_{*,p} / \bar{u}_p = k / \ln ((z - d) / z_0) \quad (37)$$

From the profile measurements, a range of couples of interdependent values of u_* , d and z_0 was obtained for every run with the modified method of least squares. Apart from u_* , the

results of the profile method can also be represented as a set of discrete pairs (d, z_0) .

Analogously to Equation 37, the following substitution may be made for the eddy-correlation measurements

$$c_e = u_* / \bar{V}_h \quad (38)$$

where u_* is deduced from $-\overline{u'w'}$ according to Equations 10 and 31 and \bar{V}_h is the average horizontal wind vector. The quantities $-\overline{u'w'}$ and \bar{V}_h were measured at a fixed height with a propeller-bivane (Sect. 4.3.2). However in Equation 38, \bar{V}_h is taken instead of the actual \bar{u} , so c_e slightly underestimates c .

The assumptions necessary for a logarithmic profile - an adapted layer and a near-neutral or neutral atmosphere - and the assumption $\bar{u} \approx \bar{V}_h$ lead to

$$c_e = k / \ln ((z - d) / z_0) \quad (39)$$

For the fixed height where the eddy-correlation measurements are taken, this equation leads for every run to a relation between the unknown quantities d and z_0 . The simultaneous set of pairs (d, z_0) resulting from the profile method did not coincide with this relation, as shown for one particular measurement in Figure 26.

Figure 26 illustrates once more that d cannot be accurately estimated from the profile measurements: d varies from 0.90 m to 1.30 m! In great majority, the two simultaneous curves d against z_0 intersect for values of d within that interval. The point of intersection indicates values of d and of z_0 that fit the results of both methods of measure-

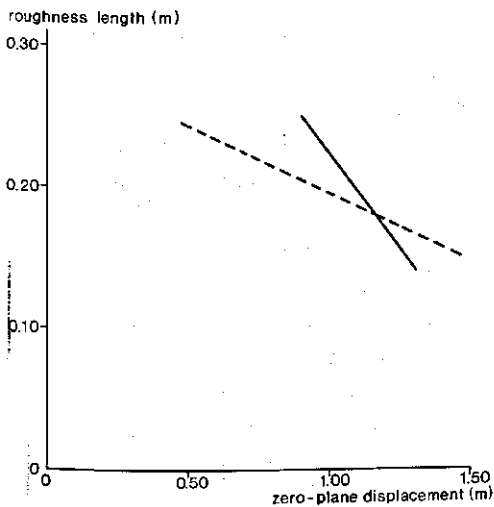

Fig. 26. Estimate of zero-plane displacement d and roughness length z_0 from wind-profile measurements and eddy-correlation measurements.

— = z_0 plotted against d estimated from wind-profile measurements;
 - - - = z_0 plotted against d estimated from eddy-correlation measurements.

ment. In this way, one value of d and z_0 was obtained for any run where profile measurements and eddy-correlation measurements were available. The Tables 11 and 12 show the results of this approach. For each run, the zero-plane displacement and the roughness length were estimated with the c_e of that particular run. Also a daily mean c_e could be applied, but led to the same final results. When the c_e of each particular run was used, the differences between the runs would not be eliminated at once and the identity of each run would be maintained.

If the adapted layer were assumed to extend above the greatest height of measurement, for the procedure described above to estimate d a profile was used with 5, 4 and 3 heights of measurement, respectively. The mean of these d values was chosen as the final estimate of d . This weighted mean was chosen because the upper boundary of the adapted layer and thus the number of heights of measurement within the layer were not always exactly known. If only 4 heights of measurement were in the adapted layer, d is in general estimated by averaging d from a profile with 4 heights and a profile with 3 heights.

When d was found, u_* and z_0 were estimated from the profile measurements by the modified method of least squares. For the underestimation of c_e caused by the use of \bar{v}_h instead of \bar{u} , a correction is made later (Sect. 6.5).

6.3 DEPENDENCE OF d AND z_0 ON WIND VELOCITY AND ON ATMOSPHERIC CONDITIONS

In the literature, there is no common opinion about the relationship between zero-plane displacement and wind velocity, nor about that of roughness length and wind velocity. For instance, Stanhill & Fuchs (1968) and Kalma & Stanhill (1972) did not find any dependence between d and wind velocity. However according to experimental results of Mikammal et al. (1966), d should depend on wind velocity and on atmospheric conditions.

To examine these dependences for the present experiment, the estimates of d and z_0 are plotted against the mean wind velocity at a fixed height (Table 13). The Figures 27, 28, 29, 30, 31, 32, 33 and 34 do not show any systematic dependence of d on \bar{u} or of z_0 on \bar{u} . In this experiment, however, the wind velocities ranged from 2 m/s to only 6 m/s and therefore the picture is not complete. In other words: for these low wind velocities no systematic relation could be demonstrated, but such a relation for larger wind velocities, for instance 8 - 12 m/s, is not excluded by the present research.

The atmospheric conditions are usually defined by the stability parameter z/L (Sect. 2.1.2). This parameter is estimated from the eddy-correlation measurements at 3 m above the zero-plane displacement. Table 13 shows that the measurements, selected for the estimation of d , z_0 and u_* (Sect. 6.2), were taken in a near-neutral or neutral atmosphere for in general $-0.03 < z/L < 0$. This range of z/L is too small for a thorough examination of the dependence of d or z_0 on z/L that could lead to conclusions about any interrelation between these quantities. But here again the experimental data do not exclude a definite relation, if a larger range of z/L were considered.

Table 11. Mean zero-plane displacement \bar{d} , mean roughness length z_0 and mean friction velocity u_* at Masts 1 and 3 estimated from a comparison of simultaneous wind-profile and eddy-correlation measurements in 1975.

Mast	Date	\bar{d} calculated from			Number of hts in adapted layer	Mean of				
		5	4	3		\bar{d} (m)	z_0 (m)	u_* (m/s)		
		hts of measurement								
1	1975-08-13	1.57	1.56	1.57	5	1.57	0.17	0.44		
		1.31	1.36	1.40	5	1.36	0.23	0.55		
		1.65	1.63	1.62	5	1.63	0.17	0.44		
		1.52	1.53	1.53	5	1.53	0.21	0.46		
	1975-08-14	1.25	1.29	1.32	5	1.29	0.26	0.44		
		1.50	1.50	1.41	3	1.41	0.22	0.50		
		.	1.51	1.39	3	1.39	0.21	0.52		
		.	1.54	1.43	3	1.43	0.21	0.53		
		1.67	1.65	1.57	3	1.57	0.17	0.46		
		1.32	1.34	1.26	3	1.26	0.22	0.46		
		1.57	1.57	1.46	3	1.46	0.18	0.45		
		1.47	1.48	1.48	5	1.48	0.21	0.41		
	1975-08-27	1.31	1.30	1.27	5	1.29	0.22	0.41		
		1.46	1.43	1.38	3	1.38	0.18	0.32		
	1975-08-28	1.23	1.23	1.19	3	1.19	0.26	0.45		
		1.57	1.54	1.46	3	1.46	0.18	0.53		
		1.58	1.58	1.51	3	1.51	0.22	0.54		
		1.59	1.58	1.48	3	1.48	0.19	0.47		
		1.16	1.12	1.02	3	1.02	0.29	0.46		
		1.57	1.55	1.46	3	1.46	0.17	0.42		
		1.57	1.57	1.49	3	1.49	0.19	0.41		
		1.80	1.80	1.79	3	1.79	0.16	0.38		
		.	1.52	1.39	3	1.39	0.23	0.37		
		1.71	1.70	1.61	3	1.61	0.16	0.37		
		3	1975-08-13	1.55	1.57	1.49	3	1.49	0.18	0.44
				1.51	1.53	1.47	3	1.47	0.22	0.53
	.			.	1.71	3	1.71	0.14	0.43	
	.			.	1.47	3	1.47	0.20	0.43	
1975-08-14	.		.	1.35	3	1.35	0.25	0.44		
	1.56		1.54	1.52	3	1.52	0.21	0.49		
	1.67		1.65	1.62	3	1.62	0.17	0.51		
	1.59		1.55	1.50	3	1.50	0.20	0.52		
	1.72		1.66	1.60	3	1.60	0.17	0.46		
	1.46		1.46	1.42	3	1.42	0.21	0.44		
	.		1.71	1.63	3	1.63	0.17	0.45		
	1.33		1.49	1.41	3	1.41	0.21	0.40		
1975-08-27	1.59		1.55	1.49	3	1.49	0.21	0.41		
	1.82		1.78	1.74	3	1.74	0.16	0.32		
1975-08-28	1.48		1.47	1.39	3	1.39	0.24	0.46		
	1.66		1.64	1.59	3	1.59	0.18	0.53		
	1.44		1.44	1.38	3	1.38	0.24	0.52		
	1.73		1.71	1.64	4	1.67	0.18	0.45		
	1.51		1.52	1.49	3	1.49	0.25	0.44		
	1.71		1.73	1.65	3	1.65	0.16	0.41		
	1.65		1.63	1.56	3	1.56	0.19	0.44		
	1.73		1.71	1.64	3	1.64	0.16	0.38		
	1.63		1.61	1.53	3	1.53	0.22	0.35		
	1.75		1.76	1.75	3	1.75	0.16	0.34		

Table 12. Mean zero-plane displacement \bar{d} , mean roughness length z_0 and mean friction velocity u_* at Masts 1 and 2 estimated from a comparison of simultaneous wind-profile and eddy-correlation measurements in 1976.

Mast	Date	\bar{d} calculated from			Number of hts in adapted layer	Mean of				
		5	4	3		\bar{d} (m)	z_0 (m)	u_* (m/s)		
		hts of measurement								
1	1976-08-14	1.12	1.09	1.04	5	1.08	0.23	0.48		
		1.05	1.05	1.06	5	1.05	0.21	0.45		
		1.23	1.23	1.16	5	1.19	0.19	0.45		
		1.33	1.33	1.27	4	1.33	0.16	0.48		
		1.28	1.29	1.29	4	1.29	0.16	0.47		
		1.32	1.32	1.29	5	1.31	0.17	0.53		
		1.45	1.42	1.36	5	1.41	0.15	0.50		
		1976-08-15	1.02	1.00	0.99	4	1.00	0.21	0.40	
			1.44	1.43	1.34	3	1.34	0.16	0.46	
			1.11	1.07	0.95	3	0.95	0.22	0.60	
	1.15		1.13	1.07	3	1.07	0.22	0.59		
	1.27		1.23	1.15	3	1.15	0.20	0.55		
	1.42		1.36	1.32	4	1.34	0.16	0.52		
	1.30		1.29	1.26	3	1.26	0.17	0.58		
	1976-08-19		1.37	1.37	1.29	3	1.29	0.15	0.39	
			1.26	1.24	1.16	3	1.16	0.22	0.59	
			1.28	1.26	1.20	3	1.20	0.20	0.57	
		1.45	1.40	1.35	5	1.40	0.16	0.56		
		1.34	1.31	1.25	5	1.28	0.21	0.67		
		1.35	1.31	1.24	5	1.27	0.19	0.63		
		1.29	1.27	1.22	4	1.27	0.17	0.64		
		1976-08-20	1.11	1.13	1.18	5	1.14	0.19	0.40	
			1.17	1.13	1.09	5	1.16	0.18	0.41	
			1.07	1.05	1.03	5	1.05	0.20	0.44	
	1.27		1.21	1.09	3	1.09	0.21	0.46		
	1.06		1.04	1.02	5	1.04	0.20	0.51		
	1.35		1.30	1.30	4	1.30	0.17	0.53		
	1.29		1.26	1.23	5	1.26	0.18	0.62		
	1.33		1.24	1.24	4	1.24	0.17	0.56		
	1976-08-26		1.38	1.36	1.39	5	1.37	0.16	0.44	
			1.43	1.40	1.42	5	1.42	0.15	0.47	
		1.15	1.09	1.08	3	1.08	0.21	0.57		
		1.29	1.20	1.13	3	1.13	0.21	0.59		
		1.38	1.32	1.37	4	1.34	0.18	0.70		
		1.45	1.38	1.31	3	1.31	0.17	0.69		
		1.45	1.38	1.33	3	1.33	0.16	0.60		
		2	1976-08-14	1.05	1.00	.	4	1.00	0.24	0.50
				1.13	1.11	1.03	3	1.03	0.21	0.47
				1.03	1.01	1.04	4	1.03	0.20	0.45
	1.16			1.18	1.08	3	1.08	0.18	0.48	
1.30	1.23			1.16	3	1.16	0.16	0.46		
1.12	1.10			1.07	3	1.07	0.19	0.55		
1976-08-15	1.29		1.23	1.23	4	1.23	0.16	0.49		
	0.93		0.91	0.83	3	0.83	0.22	0.39		
	1.20		1.20	1.20	3	1.20	0.17	0.48		
	1.10		1.07	1.07	4	1.07	0.21	0.59		
	1.14		1.13	1.13	5	1.13	0.22	0.58		
	1.31		1.24	1.22	3	1.22	0.19	0.59		
	1.29		1.24	1.16	3	1.16	0.18	0.53		
	1.25		1.20	1.18	3	1.18	0.18	0.59		

Table 12. continued

Mast	Date	\bar{d} calculated from			Number of hts in adapted layer	Mean of		
		5	4	3		\bar{d} (m)	z_0 (m)	u^* (m/s)
		hts of measurement						
2	1976-08-19	1.38	1.38	1.38	5	1.38	0.15	0.40
		1.14	1.08	1.05	4	1.06	0.22	0.58
		1.27	1.15	1.15	4	1.15	0.21	0.57
		1.43	1.33	1.29	4	1.31	0.17	0.56
		1.07	1.02	.	4	1.02	0.23	0.65
		1.15	1.07	1.07	4	1.07	0.21	0.63
		1.43	1.37	1.37	4	1.37	0.16	0.63
	1976-08-20	1.05	0.97	0.87	4	0.92	0.21	0.40
		1.16	1.09	0.95	3	0.95	0.20	0.41
		1.15	1.12	1.05	3	1.05	0.20	0.42
		0.99	0.99	0.96	5	0.98	0.22	0.47
		1.09	1.07	0.95	3	0.95	0.20	0.51
		1.11	1.00	0.82	3	0.82	0.21	0.53
		1.12	1.10	1.03	3	1.03	0.20	0.60
	1976-08-26	1.27	1.23	1.18	3	1.18	0.18	0.55
		1.18	1.22	1.17	5	1.19	0.17	0.44
		1.29	1.24	1.20	5	1.24	0.17	0.49
		1.20	1.14	1.05	3	1.05	0.22	0.58
		1.06	1.01	0.95	3	0.95	0.21	0.57
		1.19	1.13	1.10	3	1.10	0.20	0.73
	1.23	1.19	1.13	3	1.13	0.18	0.69	
	1.27	1.21	1.12	3	1.12	0.18	0.62	

Table 13. Wind velocity, atmospheric stability z/L , zero-plane displacement d and roughness length z_0 at Masts 1 and 3 in 1975 and at Masts 1 and 2 in 1976.

Mast	Height of measur. (m)	Wind velocity (m/s)	z/L	d (m)	z_0 (m)	Mast	Height of measur. (m)	Wind velocity (m/s)	z/L	d (m)	z_0 (m)		
1975													
1	4.15	2.96	-0.03	1.57	0.17	1	3.60	3.48	-0.01	1.15	0.20		
		3.40	-0.02	1.36	0.23			3.43	-0.02	1.34	0.16		
		2.97	-0.02	1.63	0.17			3.80	-0.01	1.26	0.17		
		2.90	-0.02	1.53	0.21			2.64	-0.03	1.29	0.15		
		2.63	-0.03	1.29	0.26			3.55	-0.02	1.16	0.22		
		3.16	-0.01	1.41	0.22			3.52	-0.02	1.20	0.20		
		3.35	-0.02	1.39	0.23			3.61	-0.02	1.40	0.16		
		3.40	-0.01	1.43	0.21			4.00	-0.01	1.28	0.21		
		3.00	-0.02	1.57	0.17			3.92	-0.01	1.27	0.19		
		2.92	-0.03	1.26	0.22			4.19	-0.01	1.27	0.17		
		3.05	-0.01	1.46	0.18			2.55	-0.05	1.14	0.19		
		4.45	2.75	-0.05	1.29			0.22	2.70	-0.04	1.16	0.18	
			2.75	-0.03	1.48			0.21	2.81	-0.05	1.05	0.20	
			2.28	-0.03	1.38			0.18	2.83	-0.03	1.09	0.21	
	2.89		-0.02	1.19	0.26		3.26	-0.02	1.04	0.20			
	3.74		-0.02	1.46	0.18		3.40	-0.02	1.30	0.17			
	3.52		-0.02	1.51	0.22		3.92	-0.01	1.26	0.18			
	3.27		-0.02	1.48	0.19		3.64	-0.01	1.24	0.17			
	2.83		-0.02	1.02	0.29		2.88	-0.01	1.37	0.16			
	3.00		-0.02	1.46	0.17		3.12	-0.02	1.42	0.15			
	2.82		-0.01	1.49	0.19		3.50	-0.02	1.08	0.21			
	2.69		-0.00	1.79	0.16		3.60	-0.01	1.13	0.21			
	2.36		+0.00	1.39	0.21		4.47	-0.01	1.34	0.18			
	2.64		+0.01	1.61	0.16		4.48	-0.01	1.31	0.17			
	3		4.15	2.95	-0.03		1.49	0.18	2	3.60	3.97	-0.01	1.33
		3.32		-0.02	1.47		0.22	3.03			-0.02	1.00	0.24
		2.97		-0.02	1.71		0.14	2.93			-0.03	1.03	0.21
		2.83		-0.02	1.47		0.20	2.84			-0.03	1.03	0.20
2.66		-0.03		1.35	0.25	3.21	-0.02	1.08			0.18		
3.10		-0.01		1.52	0.21	3.15	-0.02	1.16			0.16		
3.40		-0.02		1.62	0.17	3.58	-0.01	1.07			0.19		
3.39		-0.01		1.50	0.20	3.28	-0.01	1.23			0.16		
3.12		-0.02		1.60	0.17	2.50	-0.04	0.83			0.22		
2.82		-0.03		1.42	0.21	3.20	-0.02	1.20			0.17		
3.05		-0.01		1.63	0.17	3.67	-0.01	1.07			0.21		
4.45		2.69		-0.05	1.41	0.21	3.50	-0.01			1.13	0.22	
		2.73		-0.03	1.49	0.21	3.69	-0.01			1.22	0.19	
		2.29		-0.03	1.74	0.16	3.48	-0.02			1.16	0.18	
		2.93	-0.02	1.39	0.24	3.84	-0.01	1.18		0.18			
		3.73	-0.02	1.59	0.18	2.70	-0.03	1.38		0.15			
		3.31	-0.02	1.38	0.24	3.48	-0.02	1.06		0.22			
		3.13	-0.02	1.67	0.18	3.50	-0.02	1.15		0.21			
		2.74	-0.02	1.49	0.25	3.64	-0.02	1.31		0.17			
		2.93	-0.02	1.65	0.16	4.00	-0.01	1.02		0.23			
		3.03	-0.01	1.56	0.19	3.87	-0.01	1.07		0.21			
		2.74	-0.00	1.67	0.16	4.17	-0.01	1.37		0.16			
		2.28	+0.00	1.53	0.22	2.62	-0.05	0.92		0.21			
		2.38	+0.01	1.75	0.16	2.65	-0.04	0.95		0.20			
		1976											
1		3.60	2.92	-0.02	1.08	0.23	2.71	-0.05		1.05	0.20		
			2.81	-0.03	1.05	0.21	2.92	-0.03		0.98	0.22		
			2.82	-0.03	1.19	0.19	3.26	-0.02		0.95	0.21		
	3.17		-0.02	1.33	0.16	3.42	-0.02	0.82	0.21				
	3.19		-0.02	1.29	0.16	3.83	-0.01	1.03	0.20				
	3.45		-0.01	1.31	0.17	3.54	-0.01	1.18	0.18				
	3.32		-0.01	1.41	0.15	2.91	-0.01	1.19	0.17				
	2.54		-0.04	1.00	0.21	3.19	-0.02	1.24	0.17				
	3.10		-0.02	1.34	0.16	3.57	-0.02	1.05	0.22				
	3.73		-0.01	0.95	0.22	3.60	-0.01	0.95	0.21				
	3.59		-0.01	1.07	0.22	4.68	-0.01	1.10	0.20				
						4.52	-0.01	1.13	0.18				
						4.11	-0.01	1.12	0.18				

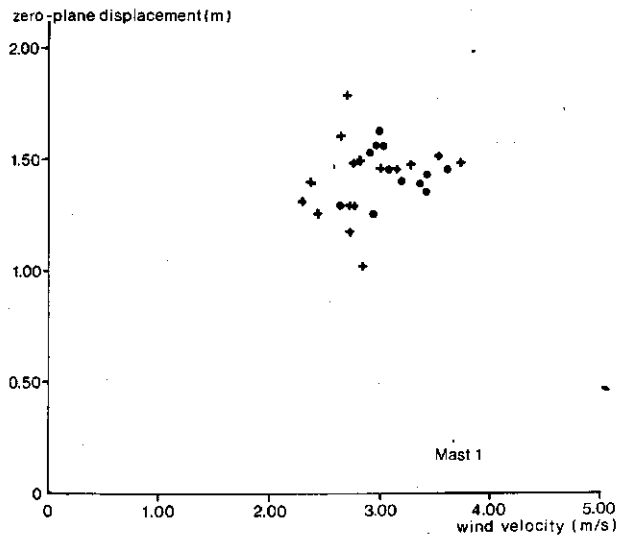

Fig. 27. Zero-plane displacement plotted against mean wind velocity above maize (Mast 1, 1975) 4.15 m above ground (●) and 4.45 m above ground (+).

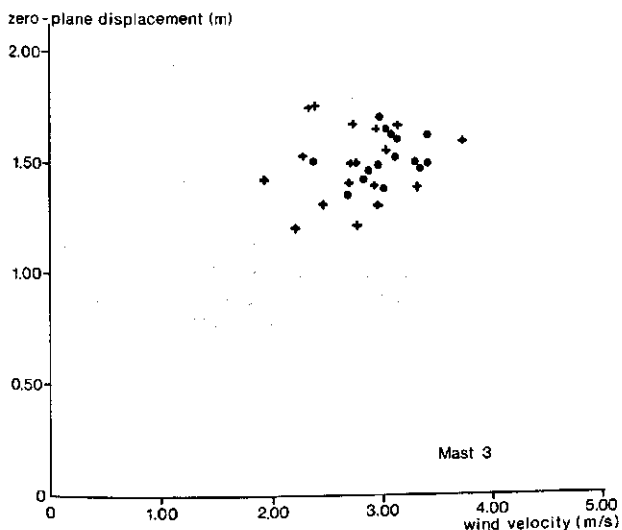

Fig. 28. Zero-plane displacement plotted against mean wind velocity above maize (Mast 3, 1975) 4.15 m above ground (●) and 4.45 m above ground (+).

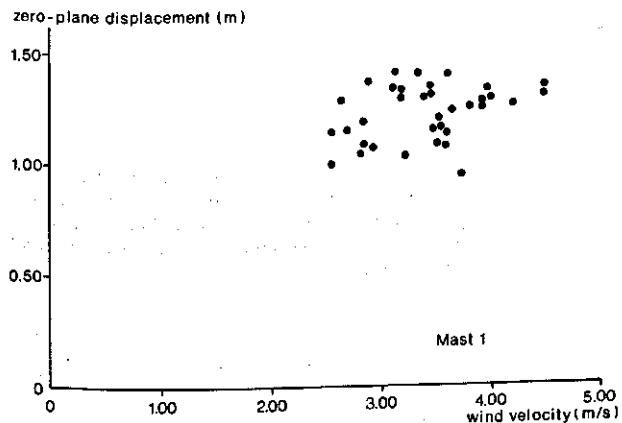

Fig. 29. Zero-plane displacement plotted against mean wind velocity above maize (Mast 1, 1976) at 3.60 m above ground.

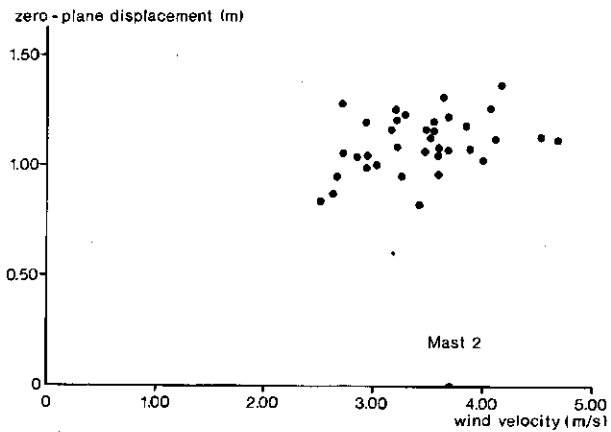

Fig. 30. Zero-plane displacement plotted against mean wind velocity above maize (Mast 2, 1976) at 3.60 m above ground.

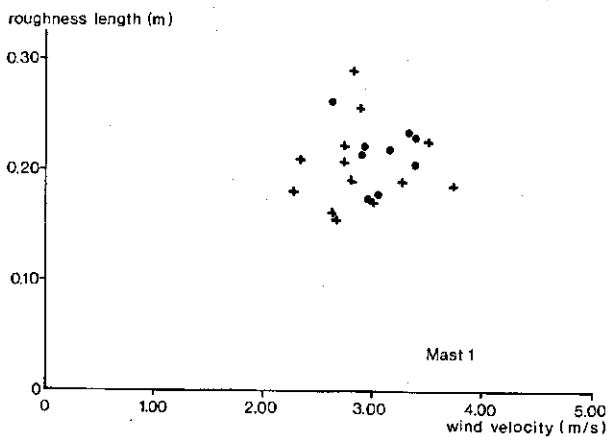

Fig. 31. Roughness length plotted against mean wind velocity above maize (Mast 1, 1975) 4.15 m above ground (●) and 4.45 m above ground (+).

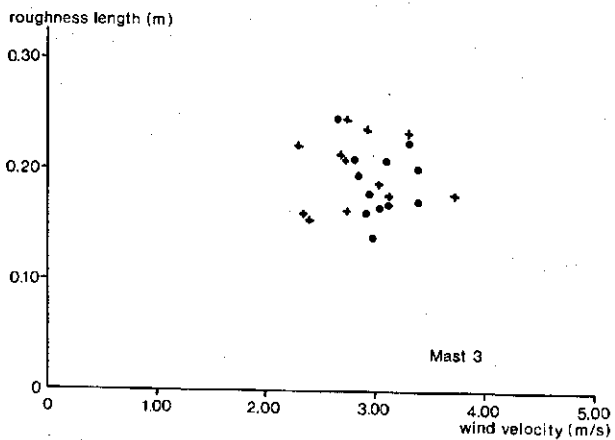

Fig. 32. Roughness length plotted against mean wind velocity above maize (Mast 3, 1975) 4.15 m above ground (●) and 4.45 m above ground (+).

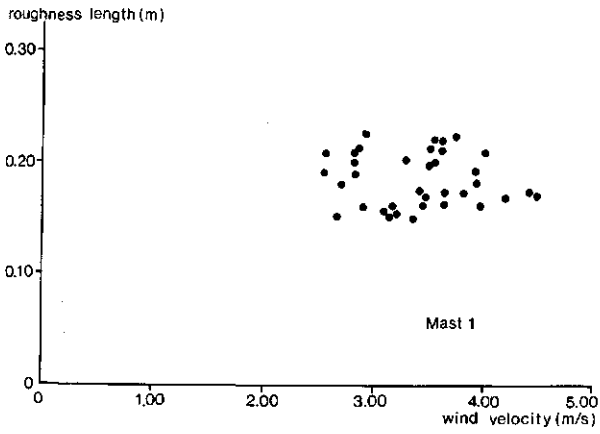

Fig. 33. Roughness length plotted against mean wind velocity above maize (Mast 1, 1976) at 3.60 m above ground.

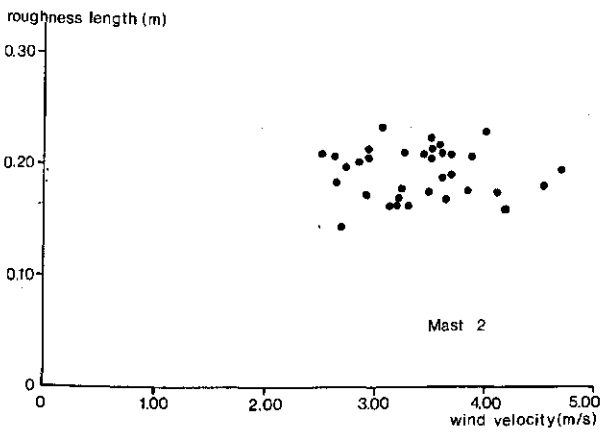

Fig. 34. Roughness length plotted against mean wind velocity above maize (Mast 2, 1976) at 3.60 m above ground.

6.4 MEAN ZERO-PLANE DISPLACEMENT AND ROUGHNESS LENGTH

The estimates of d and z_0 from the present measurements do not depend on wind velocity or atmospheric conditions (Sect. 6.3). So it was justifiable to estimate a daily mean of d and z_0 derived from measurements taken on the same day (Table 14). Also a mean of d and z_0 of the whole season was calculated from all measurements taken above the full-grown crop.

Table 14 shows that the means of d at Mast 1 and Mast 3 in 1975 and also those at Mast 1 and Mast 2 in 1976 differed from one to another. Before interpreting this difference, one should reconsider the method applied to estimate d and z_0 . To estimate d and z_0 from the results of the wind-profile method and the eddy-correlation method, the air flow over the site was assumed to be homogeneous. So within the adapted layer the mean wind velocity \bar{u} at a particular height would have the same value over the whole site of measurement, just as u_* and $c (= u_*/\bar{u})$.

Table 14. Mean zero-plane displacement d and mean roughness length z_0 and their standard deviations.

Date	Number of runs	Mast 1, daily mean		Mast 3, daily mean	
		d (m)	z_0 (m)	d (m)	z_0 (m)
1975-08-13	5	1.48 ± 0.14	0.21 ± 0.04	1.50 ± 0.13	0.20 ± 0.04
1975-08-14	6	1.42 ± 0.10	0.20 ± 0.02	1.55 ± 0.08	0.19 ± 0.02
1975-08-27	3	1.38 ± 0.10	0.20 ± 0.02	1.55 ± 0.17	0.19 ± 0.03
1975-08-28	10	1.44 ± 0.21	0.21 ± 0.04	1.57 ± 0.12	0.20 ± 0.04
		Mast 1, daily mean		Mast 2, daily mean	
		d (m)	z_0 (m)	d (m)	z_0 (m)
1976-08-14	7	1.24 ± 0.13	0.18 ± 0.03	1.09 ± 0.08	0.19 ± 0.03
1976-08-15	7	1.16 ± 0.16	0.19 ± 0.03	1.11 ± 0.13	0.19 ± 0.02
1976-08-19	7	1.27 ± 0.08	0.19 ± 0.03	1.19 ± 0.16	0.19 ± 0.03
1976-08-20	8	1.16 ± 0.10	0.19 ± 0.01	0.99 ± 0.16	0.20 ± 0.01
1976-08-26	7	1.28 ± 0.13	0.18 ± 0.03	1.11 ± 0.09	0.19 ± 0.02
		Seasonal mean		Mast	
		d (m)	z_0 (m)		
1975	24	1.43 ± 0.16	0.21 ± 0.03	1	
1975	24	1.54 ± 0.12	0.19 ± 0.03	3	
1976	36	1.22 ± 0.13	0.19 ± 0.02	1	
1976	36	1.09 ± 0.13	0.19 ± 0.02	2	
		General mean			
		d (m)	z_0 (m)		
1975	48	1.49 ± 0.15	0.20 ± 0.03	$d/h = 0.57$	$z_0/h = 0.08$
1976	72	1.16 ± 0.14	0.19 ± 0.02	$d/h = 0.55$	$z_0/h = 0.09$

Moreover regression analysis by the modified method of least squares was used to estimate d and z_0 , so that estimates of d , z_0 and u_* were mathematically interdependent (Sect. 2.2.2 and 6.2.4). So a difference between the estimates of d with the same u_* at both masts - the assumption of homogeneity - may also be interpreted as a difference between the estimates of u_* for each particular mast starting from the same d . More generally stated: a difference between the results for d could indicate a difference between the actual values of u_* .

Table 14 shows that these differences in d are *systematic*, because in 1975 d at Mast 1 is always less than d at Mast 3 and in 1976 d at Mast 1 is always larger than d at Mast 2. Therefrom it is improbable that the difference could be caused by the use of the method of least squares.

Physically, differences in the value of the zero-plane displacement d may be caused by irregularities of crop height, by irregularities of crop density or by irregularities of soil surface (unequal level of reference). However none of these irregularities was observed near the masts mentioned in this section. Therefore a physical interpretation of the systematic differences observed between masts could not be found in this way.

The next trial was to interpret the differences between the estimates of d from a difference in u_* between masts. This interpretation suggests that the air flow over the site of measurement was not homogeneous. Because crop and soil surface did not show obvious irregularities and upwind obstacles were absent, inhomogeneity of air flow might result from too small a fetch. To estimate d , z_0 and u_* , however, the effects of a small fetch were already eliminated, as all heights of measurement that were supposed to be outside the adapted layer were omitted. Nevertheless it is difficult to indicate exactly the upper boundary of the adapted layer, because only a few points of measurement were available in one wind profile. So one cannot exclude that some points of measurement were in reality outside the adapted layer.

To examine the homogeneity of air flow more rigorously, the mean wind velocity over one day at a fixed height at both masts was reconsidered (Table 15). Data were taken from the measuring days when the wind was constant in direction as well as in velocity and

Table 15. Daily mean wind velocity \bar{u} measured at one height and daily mean zero-plane displacement d at Masts 1 and 3 (1975) and at Masts 1 and 2 (1976).

Date	Mast	\bar{u}	d	Mast	\bar{u}	d	Height above ground level
		(m/s)	(m)		(m/s)	(m)	(m)
1975-08-13	1	2.97	1.48	3	2.95	1.50	4.15
1975-08-14	1	3.15	1.42	3	3.15	1.55	4.15
1975-08-27	1	2.59	1.38	3	2.57	1.55	4.45
1975-08-28	1	2.98	1.44	3	2.92	1.57	4.45
1976-08-14	1	3.10	1.24	2	3.15	1.09	3.60
1976-08-15	1	3.38	1.16	2	3.41	1.11	3.60
1976-08-19	1	3.63	1.27	2	3.62	1.19	3.60
1976-08-20	1	3.14	1.16	2	3.12	0.99	3.60
1976-08-26	1	3.72	1.28	2	3.80	1.11	3.60

measurements were collected for two masts. Comparison of these two daily mean values should bring to light any systematic differences between the two masts that might result from an inhomogeneous wind-velocity distribution. Mean wind velocity was chosen for this purpose, because this quantity is observed directly in contrast to the derived quantity u_* .

Table 15 shows that, based on a comparison of two mean wind velocities at only one height, air flow could be considered homogeneous on a few days, but on the other days homogeneity was not convincingly demonstrated. Differences in \bar{d} were more important, but there was no clear relationship between the differences in mean wind velocity and those between zero-plane displacements. Therefore, if differences in \bar{d} be interpreted as differences in u_* , it would also be impossible to indicate an unambiguous connexion between differences in \bar{u} and u_* . From the above, some irregularities may be supposed, but no definite conclusion could be drawn about the inhomogeneity of the air flow.

Therefore mean wind profile for each mast was calculated from all measurements taken in one season instead of from all measurements taken on one day. It was argued earlier in this section that all these measurements, when collected for the same wind direction and taken within the adapted layer, must coincide. Only incidental differences were eliminated by averaging. A comparison of mean wind profiles, instead of wind velocities at one height, means that for each mast five distinct heights of measurement (Table 16) were involved instead of only one height as in Table 15. Table 16 shows that the mean wind velocity in 1975 at Mast 1 for each height was systematically larger than at Mast 3. For the mean wind profiles in 1976 also a systematic difference can be found. Then the wind velocity recorded at Mast 2 was systematically larger than that at Mast 1.

To illustrate the effect of these differences, u_* was graphically estimated from the mean wind profiles in 1976 (Sect. 2.2.1 and Fig. 35), for each mast with the introduction of the seasonal mean \bar{d} of that mast, namely $\bar{d} = 1.22$ m at Mast 1 and $\bar{d} = 1.09$ m at Mast 2. From these graphs, the same u_* , 0.53 m/s, was obtained for the two masts, as expected, bearing in mind the method of estimating \bar{d} , z_0 and u_* (Sect. 6.2.4). This value also equals the mean of the values of u_* estimated directly from wind-profile measurements and

Table 16. Mean wind profiles in 1975 and 1976.

	Height of measur. (m)	Mast	Mean wind velocity (m/s)	Mast	Mean wind velocity (m/s)	$\bar{\Delta u}$ (m/s)
1975	3.14	1	2.39	3	2.33	+0.06
	3.71	1	2.71	3	2.67	+0.04
	4.28	1	2.97	3	2.92	+0.05
	4.85	1	3.20	3	3.17	+0.03
	5.42	1	3.38	3	3.35	+0.03
1976	3.10	1	3.08	2	3.12	-0.04
	3.40	1	3.27	2	3.31	-0.04
	3.70	1	3.45	2	3.47	-0.02
	4.00	1	3.61	2	3.63	-0.02
	4.30	1	3.88	2	3.89	-0.01

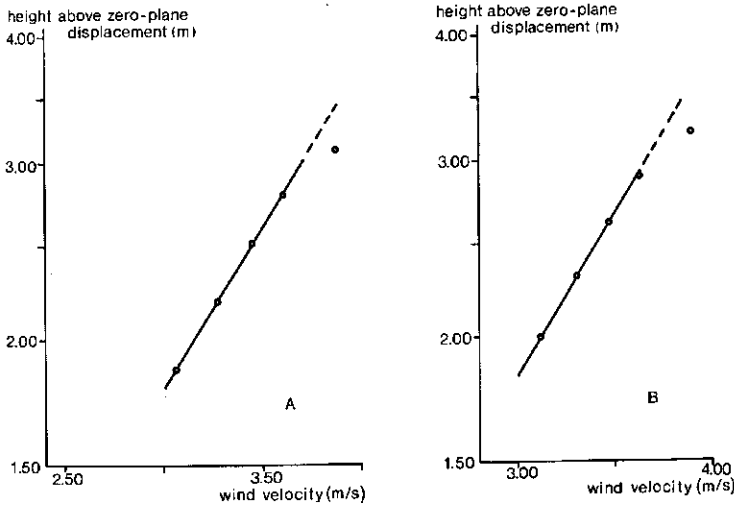

Fig. 35. Mean wind profile above maize at Mast 1 (A) and Mast 2 (B), 1976.

- A. Mast 1 $\bar{d} = 1.22$ m
 $z_0 = 0.19$ m
 $u_* = 0.53$ m/s
- B. Mast 2 $\bar{d} = 1.09$ m
 $z_0 = 0.20$ m
 $u_* = 0.53$ m/s

eddy-correlation measurements (Table 17). One can conclude from this latter result that estimation of a mean u_* from a mean wind profile, that is obtained from a large number of wind profiles measured over a long period and in a near-neutral or neutral atmosphere, is allowed.

Apart from a distinct \bar{d} for each mast, also a general mean \bar{d} was introduced for the two masts ($\bar{d} = 1.16$ m, Fig. 36). This leads to $u_* = 0.55$ m/s at Mast 1 and $u_* = 0.51$ m/s at Mast 2. This confirms the earlier conclusion that the values of u_* obtained in this

Table 17. Mean friction velocities u_* and mean roughness lengths z_0 and their standard deviations. A. Estimation from a comparison of wind-profile measurements and simultaneous eddy-correlation measurements. B. Estimation from wind-profile measurements at three heights of measurement with an empirical relationship for estimation of \bar{d} ($\bar{d} = 0.6 h$).

	Mast	u_* (m/s)	z_0 (m)	
A	1975	1	0.45 ± 0.06	0.21 ± 0.03
		3	0.44 ± 0.06	0.19 ± 0.03
	1976	1	0.53 ± 0.09	0.19 ± 0.02
		2	0.53 ± 0.09	0.19 ± 0.02
B	1975	1	0.43 ± 0.07	0.17 ± 0.02
		3	0.44 ± 0.07	0.19 ± 0.02
	1976	1	0.52 ± 0.09	0.18 ± 0.02
		2	0.50 ± 0.09	0.16 ± 0.02

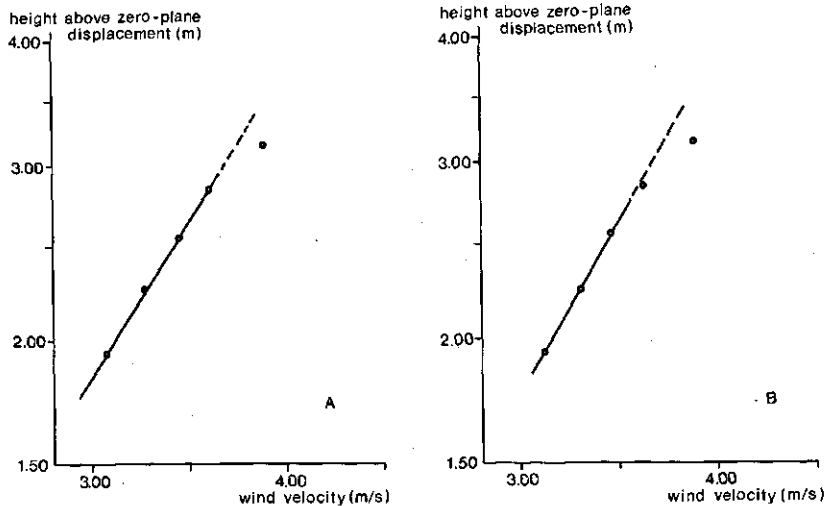

Fig. 36. Mean wind profile above maize at Mast 1 (A) and Mast 2 (B), 1976 with the same zero-plane displacement for both masts.

A. Mast 1

$$\bar{d} = 1.16 \text{ m}$$

$$z_0 = 0.21 \text{ m}$$

$$u_* = 0.55 \text{ m/s}$$

B. Mast 2

$$\bar{d} = 1.16 \text{ m}$$

$$z_0 = 0.17 \text{ m}$$

$$u_* = 0.51 \text{ m/s}$$

way differ from one to another, while the introduced values of \bar{d} were equal. The same procedure was applied to the mean wind profiles for 1975 with similar results (Fig. 37 and 38).

Moreover the graphs of the mean wind profiles (Fig. 35 and 37) show again the effects of a small fetch. At Mast 1 (1976), four heights of measurement were assumed to be in the adapted layer and thus suitable for estimation of \bar{d} , z_0 and u_* , at Mast 2 (1976) only three. However a definite conclusion about the thickness of the adapted layer could not be drawn (Chap. 5) and sometimes the third height of measurement might still have been influenced by the upwind change in surface roughness. A small systematic effect on wind velocity could cause a considerable systematic discrepancy in the estimate of \bar{d} or u_* .

From these considerations, the difference between the estimates of \bar{d} in the present research could be explained as a result of an inhomogeneity in air flow caused by a small or a too small fetch.

Differences between wind velocities in Table 15 could be explained in the same way, because the height at which the wind velocities were compared may be above the adapted layer on some days.

Although the differences in the final estimates of \bar{d} could not be exactly explained, a general mean \bar{d} and z_0 could be used for practical purposes in the present experimental field (Table 14). When measurements were taken at one single point for practical purposes in the field like the present one, a systematic error in \bar{d} should be expected of (at least) 8%, or a systematic error in u_* of 4%.

The estimates of \bar{d} for 1975 and 1976 were 1.49 and 1.16 m, respectively. The differ-

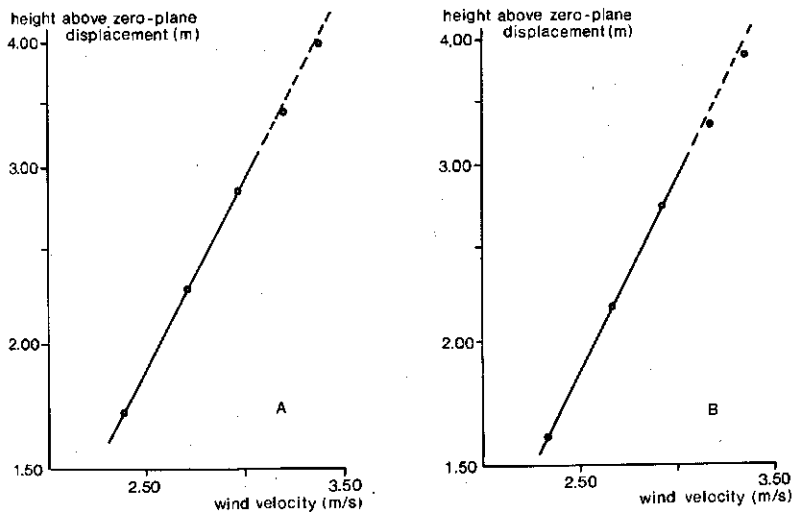

Fig. 37. Mean wind profile above maize at Mast 1 (A) and Mast 3 (B), 1975.

A. Mast 1

$$\bar{d} = 1.43 \text{ m}$$

$$z_0 = 0.21 \text{ m}$$

$$u_* = 0.45 \text{ m/s}$$

B. Mast 3

$$\bar{d} = 1.54 \text{ m}$$

$$z_0 = 0.19 \text{ m}$$

$$u_* = 0.44 \text{ m/s}$$

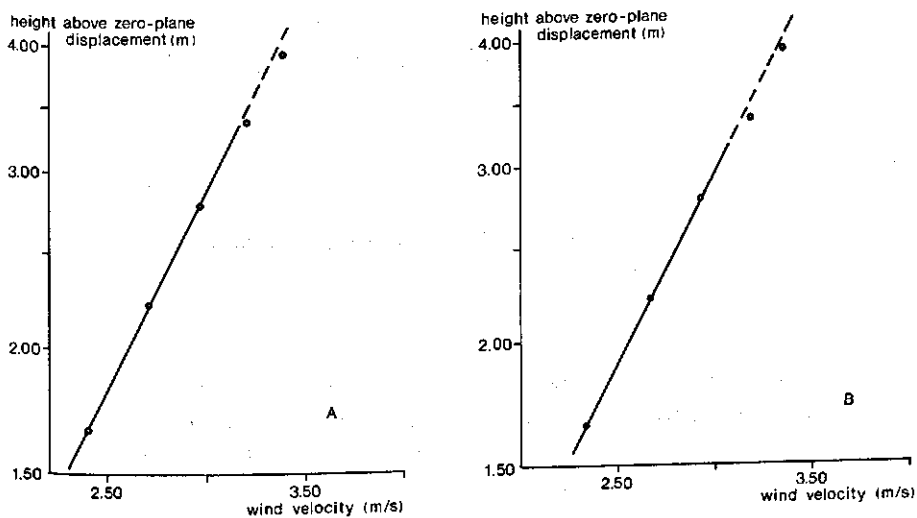

Fig. 38. Mean wind profile above maize at Mast 1 (A) and Mast 3 (B), 1975 with the same zero-plane displacement for both masts.

A. Mast 1

$$\bar{d} = 1.49 \text{ m}$$

$$z_0 = 0.19 \text{ m}$$

$$u_* = 0.44 \text{ m/s}$$

B. Mast 3

$$\bar{d} = 1.49 \text{ m}$$

$$z_0 = 0.21 \text{ m}$$

$$u_* = 0.45 \text{ m/s}$$

ence between these general mean estimates was considerably larger than the difference between the estimates of d at the two masts in one season. The present difference was explicable physically by a difference in crop height. The crop height in 1975 amounted to about 2.60 m and in 1976 to about 2.10 m.

Zero-plane displacement and roughness length often were assumed to depend only on crop height (Sect. 2.2.3). For the present maize crop, this assumption should lead to $d \approx 0.57 h$ and $z_0 \approx 0.08 h$ in 1975, and $d \approx 0.55 h$ and $z_0 \approx 0.09 h$ in 1976.

6.5 EFFECT OF OVERESTIMATION OF WIND VELOCITY

Several investigators state that cup-anemometers overestimate the actual wind velocity (Sect. 4.3.1.2). In general, the wind velocity measured with cup-anemometers is not corrected for an overestimation and so the friction velocity determined by the profile method will be overestimated to the same degree. This overestimation does not influence the quantities d and z_0 , because for d and z_0 holds $u_* / \bar{u} = k / \ln ((z - d) / z_0)$. In this equation, u_* and \bar{u} are affected to the same degree, so that $k / \ln ((z - d) / z_0)$ is insensitive to the overestimation of wind velocity.

A comparison of the wind velocities measured with cup-anemometers with results from the eddy-correlation measurements in the same field (Van Oosterum, 1977) showed that in the present experiment the wind velocity measured with a cup-anemometer (\bar{u}_p) was 7 to 8% larger than the total horizontal wind vector (\bar{V}_h) measured at the same height, so

$$\bar{u}_p \approx 1.07 \bar{V}_h \quad (40)$$

Also from eddy-correlation measurements in the same field (Bottemanne, 1977a; Van Oosterum, 1977), it follows that

$$\bar{V}_h \approx 1.05 \bar{u} \quad (41)$$

where \bar{u} is the actual mean horizontal wind velocity. From Equations 40 and 41,

$$\bar{u}_p \approx 1.12 \bar{u} \quad (42)$$

Thus the mean horizontal wind velocity \bar{u} is overestimated by about 12% when \bar{u} is measured with a cup-anemometer. This result is in agreement with Businger et al. (1971).

For estimation of d and z_0 , a coefficient c_e derived from the eddy-correlation measurements was used

$$c_e = u_* / \bar{V}_h \quad (38)$$

where u_* is the actual friction velocity and \bar{V}_h the measured total horizontal wind vector. Thus c_e was calculated with the total horizontal wind vector \bar{V}_h instead of the mean horizontal wind velocity \bar{u} as in the usual coefficient $c (= u_* / \bar{u})$.

The quantity c_e was applied for estimation of d and z_0 with the assumption

$$c_p = (u_{*,p}/\bar{u}_p) = c_e \quad (43)$$

From Equations 38, 40 and 43,

$$u_{*,p} \approx 1.07 u_* \quad (44)$$

So the actual friction velocity was overestimated by about 7% by $u_{*,p}$.

Equation 42 showed that overestimation of the actual \bar{u} amounted to about 12% and so an overestimation of about 12% of the actual u_* should be expected. However the coefficient c_e was calculated with \bar{V}_h instead of \bar{u} and so overestimation was reduced to about 7%.

When c_e is compared with the actual $c (= u_*/\bar{u})$, it follows from Equations 38 and 41 that in this experiment

$$c_e = u_*/\bar{V}_h = u_*/(1.05 \bar{u}) = 0.95 c \quad (45)$$

so c_e underestimates the actual c by 5%. If the actual c instead of c_e were introduced into the estimation of d and z_0 , c_p and so $u_{*,p}$ should be increased by 5%. Then $u_{*,p} \approx 1.12 u_*$.

The estimates of d and z_0 also change with a change of $u_{*,p}$, because these quantities are mathematically interdependent (Sect. 2.2.2). The effect of a change in c_e of 5% on the results on 20 August 1976 were calculated. They were assumed to be typical for the bulk of the measurements. Table 18 shows the quantities d , z_0 and u_* estimated in the way mentioned in Section 6.2.4 with the actual c and the influence of a small fetch also taken into account. It shows that $u_{*,p}$ increases by 5%, the actual u_* is overestimated by about 12%, d is reduced by about 14% and z_0 increased by about 23%. The roughness length considerably increased and the ratio z_0/h equalled 0.11. This ratio is in better agreement with the value of 0.1 from the literature. The ratio d/h equalled 0.5, which is less than most values in literature. Thom et al. (1975), however, found such a low value too.

Table 18. Effect of a 5% correction of c_e on zero-plane displacement d , roughness length z_0 and friction velocity u_* . Measurements 1976-08-20, Mast 1; d , z_0 and u_* were estimated with a daily mean c_e .

Run	d (m)	d (m) corr.	z_0 (m)	z_0 (m) corr.	u_* (m/s)	u_* (m/s) corr.	$\Delta u_*/u_*$ (%)
3	1.14	0.99	0.19	0.24	0.40	0.42	5.0
4	1.07	0.92	0.20	0.24	0.42	0.45	7.1
5	1.05	0.91	0.20	0.24	0.44	0.45	2.3
6	1.16	1.02	0.19	0.23	0.44	0.47	6.8
7	1.06	0.91	0.20	0.24	0.51	0.54	5.9
8	1.27	1.15	0.18	0.22	0.53	0.57	7.5
10	1.26	1.13	0.18	0.22	0.62	0.65	4.8
11	1.19	1.05	0.19	0.23	0.57	0.60	5.3
mean	1.15	1.01	0.19	0.23	0.49	0.52	5.6
s.d.	0.14	0.11	0.02	0.03	0.08	0.08	

6.6 AN EMPIRICAL RELATIONSHIP OF CROP PARAMETERS

In this research, the quantities d , z_0 and u_* were estimated from the results of wind-profile measurements and eddy-correlation measurements. In actual agricultural research, the zero-plane displacement is often estimated from empirical relationships of crop parameters (Sect. 2.2.3), because estimation of d from actual measurements is difficult, as confirmed again in this research.

An empirical relationship $d = 0.6 h$ is often applied, although in the literature several other values of d/h have been suggested. When this first relationship is applied in the present experiment, u_* and z_0 can be directly estimated from the wind-profile measurements by Equation 13. For this estimate, only the lower three points of measurement were used, in order to minimize the influence of a small fetch.

The estimates of u_* and z_0 resulting from this approach are listed in Table 17. If this empirical relationship be applied, however, a systematic error in u_* and z_0 would occur. In the present approach, this systematic error in the mean of u_* was 4 to 6% when u_* was compared with the mean of u_* from the wind-profile and eddy-correlation measurements (and $d = 0.55 h$). The actual systematic error in the mean estimate of u_* , however, amounted to about 10%, because u_* estimated from these measurements would increase by about 5% (Sect. 6.5). The actual systematic error in z_0 was considerably larger and amounted to 30 to 40%, if $d = 0.5 h$.

7 Measurements above grass

The period of measurement for grass is less restricted than for maize. As the pasture is regularly grazed, the grass lacks the extreme change in appearance of a developing maize crop till the full-grown stage. So a larger number of runs was available for estimation of u_* and z_0 of the grass plot.

7.1 WIND PROFILE ABOVE GRASS

In general, the wind-profile measurements above grass fitted the logarithmic model (Fig. 39). Moreover for a surface with small roughness elements like a pasture, the zero-plane displacement can be neglected. Sometimes, however, the upper heights of measurement deviated from the logarithmic model.

These deviations could be caused in the first place by unstable conditions. If the atmosphere be unstable, the influence on the wind velocity at the upper heights of measurement cannot be neglected (Sect. 2.1.2) and deviations from the straight line \bar{u} against $\ln z$ will occur (Fig. 40). For a small height of measurement, these deviations could be neglected and a neutral atmosphere could be accepted as a good approximation. So in the present experiment, stability corrections were not applied and, if there were deviations at

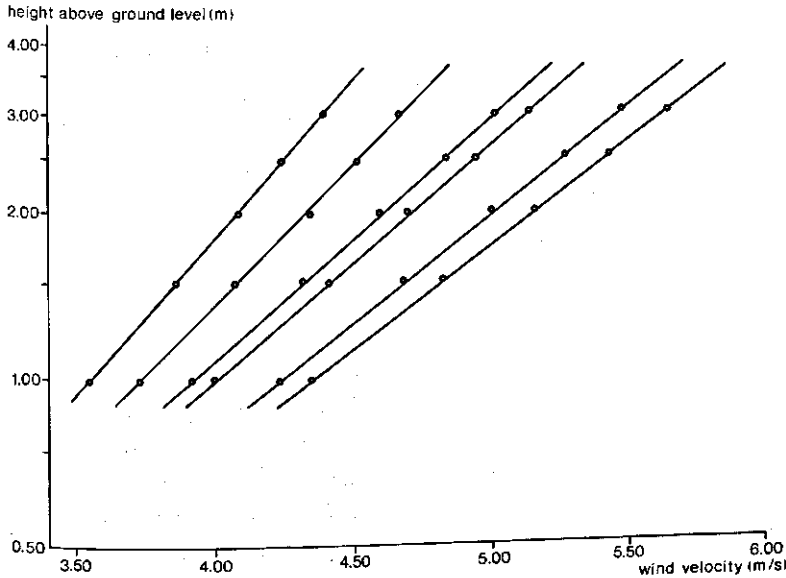

Fig. 39. Logarithmic wind profiles above grass under neutral conditions.

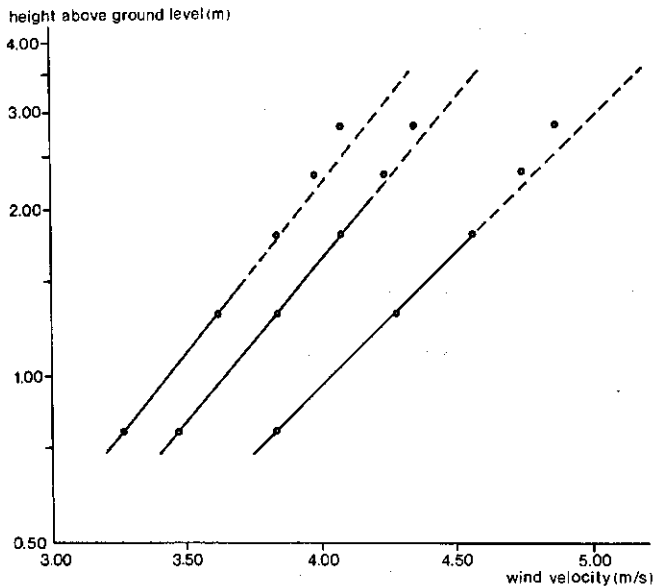

Fig. 40. Wind profiles above grass under unstable conditions.

the upper heights, only the lower heights were taken for estimation of u_* and z_0 .

The second possible reason for the deviations could be a small or a too small fetch. For a north-easterly wind, the buildings of the Experimental Station (Fig. 6) would disturb the air flow over the experimental pasture. Also the wire fence, separating Plot 9 and Plot 10 could disturb air flow over Plot 10 (Fig. 41). If so, the upper heights of measurement were omitted.

As mentioned before, for a pasture the zero-plane displacement can be neglected. Therefore under the same conditions, the measuring layer (Sect. 5.5) will be thicker than for a surface with tall roughness elements. Consequently in the arrangement above grass the difference in height between the successive sensors could be larger than in the arrangement above the maize crop. Probably as a result of this, the graphical method to estimate u_* and z_0 proved successful for the measurements above grass.

7.2 FRICTION VELOCITY AND ROUGHNESS LENGTH

The estimated friction velocity was plotted against the measured wind velocity at 2.50 m above ground level. For each plot, those measurements were used that were taken in a period during which the height and the condition of the grass did not appreciably change. Figure 42 shows that for the 1975 measurements, the relationship $u_* = 0.076 \bar{u}_{2.50}$ applied for Plot 10. Figure 43 and Figure 44 show that for the 1976 measurements $u_* = 0.080 \bar{u}_{2.50}$ for Plot 10 and $u_* = 0.061 \bar{u}_{2.50}$ for Plot 9. The straight lines were drawn by eye. The ratio u_*/\bar{u} had different values for an ordinary grass surface. More generally the estimate of u_*/\bar{u} depended on height of measurement, crop height and crop condition. This is evident from Equation 2:

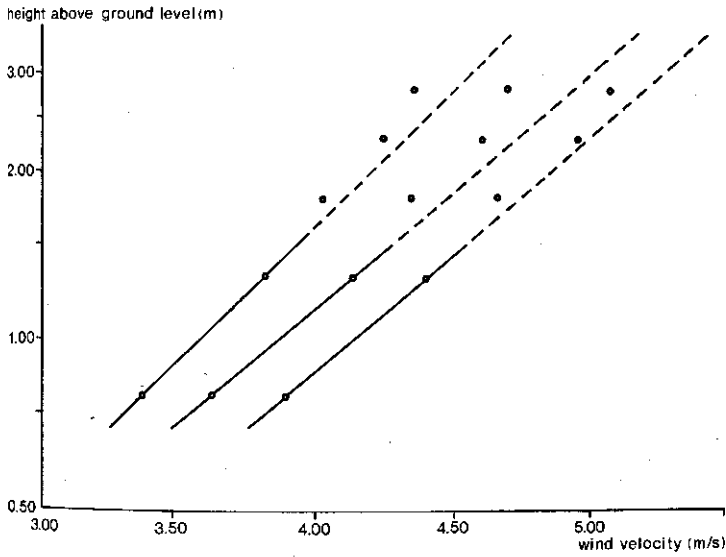

Fig. 41. Wind profiles above grass disturbed by the influence of the buildings of the Experimental Station or of wire fences.

$$u_* / \bar{u} = k / \ln(z/z_0) \tag{46}$$

With the introduction of the ratio u_* / \bar{u} , a mean roughness length was estimated from this equation: 0.013 m for Plot 10 in 1975 and 0.017 m for the same plot in 1976. For Plot 9 in 1976, z_0 was 0.004 m.

The roughness length was also estimated for each run directly from the wind-profile measurements with the graphical method (Sect. 7.1). The mean of these estimates of z_0 for

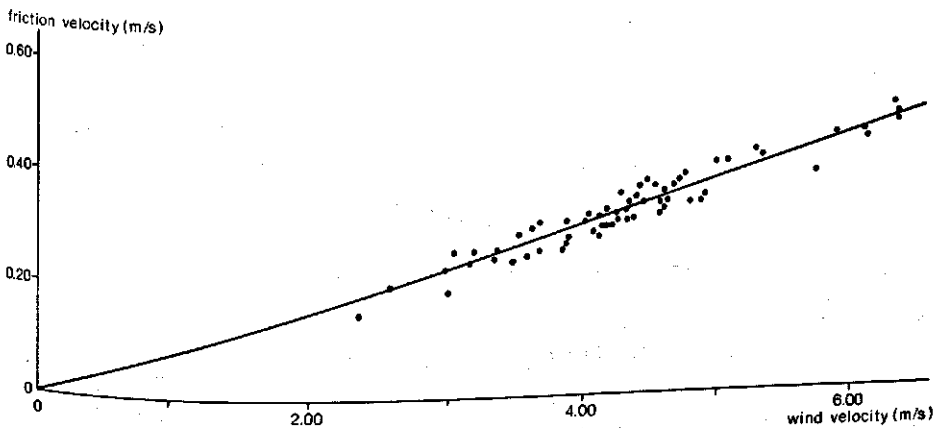

Fig. 42. Friction velocity above grass (Plot 10, 1975) plotted against mean wind velocity 2.50 m above ground: $u_* = 0.076 u_{2.50}$. The mean wind velocity was read from the assumed logarithmic wind profile drawn through the three lowest heights of measurement, and so corrected for unstable conditions or influences of a small fetch.

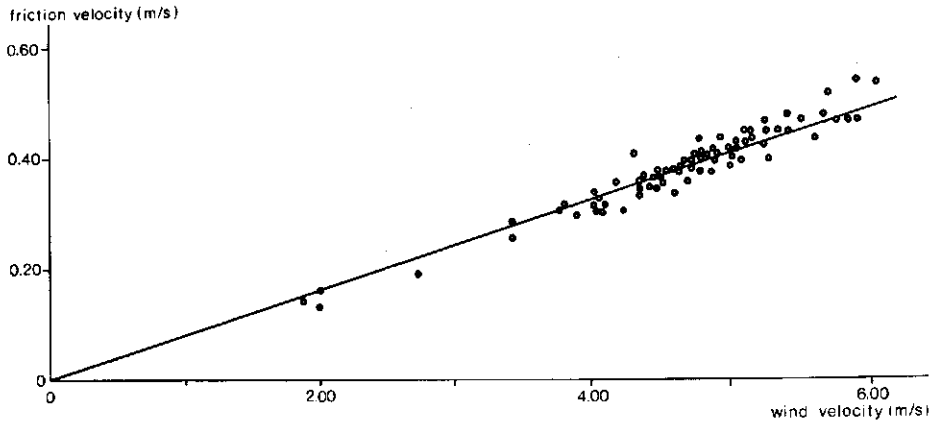

Fig. 43. Friction velocity above grass (Plot 10, 1976) plotted against mean wind velocity 2.50 m above ground: $u_* = 0.080 u_{2.50}$. The mean wind velocity was read from the assumed logarithmic wind profile drawn through the three lowest heights of measurement, and so corrected for unstable conditions or influences of a small fetch.

Plot 10 was in 1975 0.013 ± 0.005 m and in 1976 0.018 ± 0.005 m. The mean estimate of z_0 for Plot 9 in 1976 was 0.003 ± 0.002 m. So the mean estimates calculated from Equation 46 agree well with the mean z_0 estimated from the graphical method. The small value of z_0 for Plot 9 was attributable to the short grass on this plot (Sect. 4.2.1).

Table 19 shows the daily mean estimates of z_0 of all measurements on Plot 10 in 1976. It distinguishes the influence of drought on crop condition. After a period of drought in July, the grass became weedy and withered. Table 19 shows that in August the roughness length decreased considerably.

Figure 45 and Figure 46 show the roughness length plotted against the mean wind velocity 2.50 m above ground for Plot 10 in 1975 and 1976, respectively. No conclusion could be

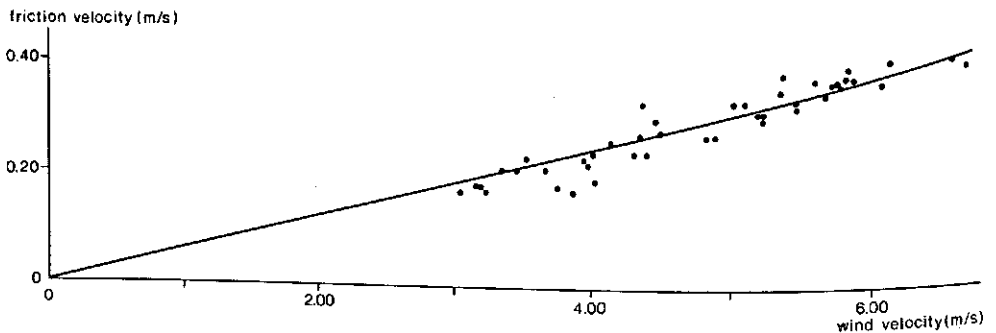

Fig. 44. Friction velocity above grass (Plot 9, 1976) plotted against mean wind velocity 2.50 m above ground: $u_* = 0.061 u_{2.50}$. The mean wind velocity was read from the assumed logarithmic wind profile drawn through the three lowest heights of measurement, and so corrected for unstable conditions or influences of a small fetch.

Table 19. Daily mean roughness lengths z_0 and standard deviations of grass. Plot 10 in 1976.

Date	Roughness length (m)
1976-06-16	0.018 ± 0.003
1976-06-17	0.015 ± 0.003
1976-06-29	0.015 ± 0.003
1976-06-30	0.018 ± 0.004
1976-07-01	0.019 ± 0.004
1976-07-02	0.018 ± 0.004
1976-07-06	0.023 ± 0.005
1976-07-07	0.031 ± 0.003
1976-08-10	0.017 ± 0.004
1976-08-11	0.012 ± 0.004
1976-08-12	0.009 ± 0.004

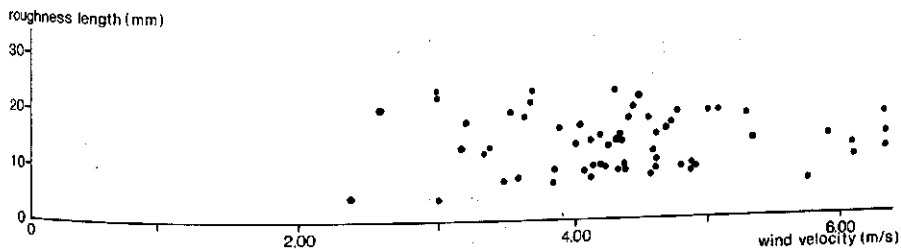

Fig. 45. Roughness length of grass (Plot 10, 1975) plotted against mean wind velocity 2.50 m above ground. The mean wind velocity was read from the assumed logarithmic wind profile drawn through the three lowest heights of measurement, and so corrected for unstable conditions or influences of a small fetch.

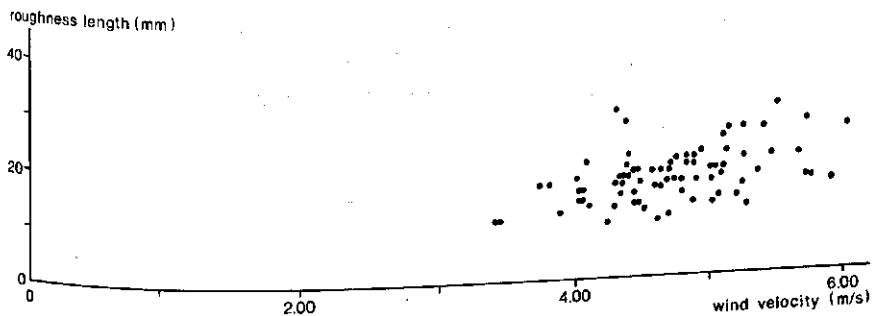

Fig. 46. Roughness length of grass (Plot 10, 1976) plotted against mean wind velocity 2.50 m above ground. The mean wind velocity was read from the assumed logarithmic wind profile drawn through the three lowest heights of measurement, and so corrected for unstable conditions or influences of a small fetch.

drawn about the dependence of the roughness length on wind velocity, because no data about z_0 for large wind velocities (e.g. 8 - 12 m/s) were available. However Figure 45 and Figure 46 do not show a relationship between z_0 and \bar{u} for the present range of wind velocities (3 - 6 m/s). The same result was derived for Plot 9 in 1976 (Fig. 47). Moreover for Plot 9, a perceptible dependence of z_0 on wind velocity could hardly be expected because z_0 was very small.

7.3 COMPARISON OF RESULTS FROM MEASUREMENTS ABOVE GRASS AND MAIZE

Figures 48 and 49 show the mean wind velocity above maize 2.50 m above zero-plane displacement plotted against the mean wind velocity above grass 2.50 m above ground. The graphical plots show that

$$\begin{aligned}\bar{u}_{\text{maize}} &= 0.70 \bar{u}_{\text{grass}} && \text{for Plot 10 in 1975} \\ \bar{u}_{\text{maize}} &= 0.67 \bar{u}_{\text{grass}} && \text{for Plot 9 in 1976}\end{aligned}\tag{47}$$

With these results and with the relationships between u_* and \bar{u} for grass and maize, a relationship between $u_{*,\text{maize}}$ and $u_{*,\text{grass}}$ was derived. The relationship between u_* and \bar{u} for the grass plots were (Sect. 7.2)

$$\begin{aligned}u_{*,\text{grass}} &= 0.076 \bar{u}_{\text{grass}} && \text{for Plot 10 in 1975} \\ u_{*,\text{grass}} &= 0.061 \bar{u}_{\text{grass}} && \text{for Plot 9 in 1976}\end{aligned}\tag{48}$$

and for the maize crop (Sect. 6.2.4)

$$\begin{aligned}u_{*,\text{maize}} &= 0.161 \bar{u}_{\text{maize}} && \text{in 1975} \\ u_{*,\text{maize}} &= 0.165 \bar{u}_{\text{maize}} && \text{in 1976}\end{aligned}\tag{49}$$

The estimates of u_* and \bar{u} in these results for grass and maize were not corrected for the overestimation of wind velocity from cup-anemometers. The relationships between u_* and \bar{u} for maize were derived from the mean coefficient c_e from the eddy-correlation measurements

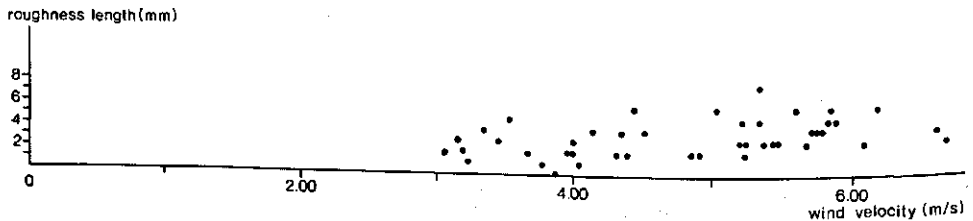

Fig. 47. Roughness length of grass (Plot 9, 1976) plotted against mean wind velocity 2.50 m above ground. The mean wind velocity was read from the assumed logarithmic wind profile drawn through the three lowest heights of measurement, and so corrected for unstable conditions or influences of a small fetch.

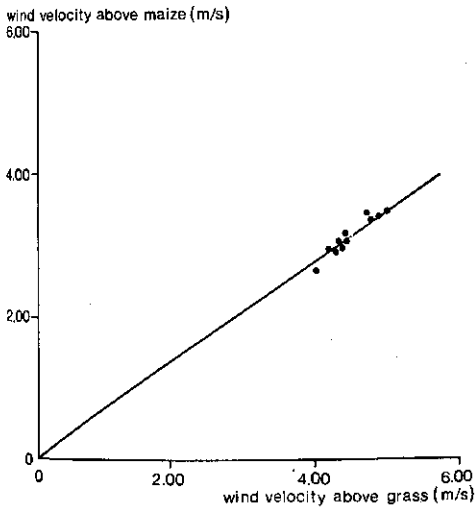

Fig. 48. Mean wind velocity above maize (Mast 1) 2.50 above zero-plane displacement plotted against mean wind velocity above grass (Plot 10) 2.50 m above ground in 1975:
 $u_{\text{maize}} = 0.70 u_{\text{grass}}$

(Sect. 6.2.4) with a correction of 5% for the introduction of \bar{v}_h instead of \bar{u} (Sect. 6.5).
 From the Equations 47, 48 and 49,

$$u_{*,\text{maize}} \approx 1.48 u_{*,\text{grass}} \quad \text{in 1975} \quad (50)$$

$$u_{*,\text{maize}} \approx 1.81 u_{*,\text{grass}} \quad \text{in 1976}$$

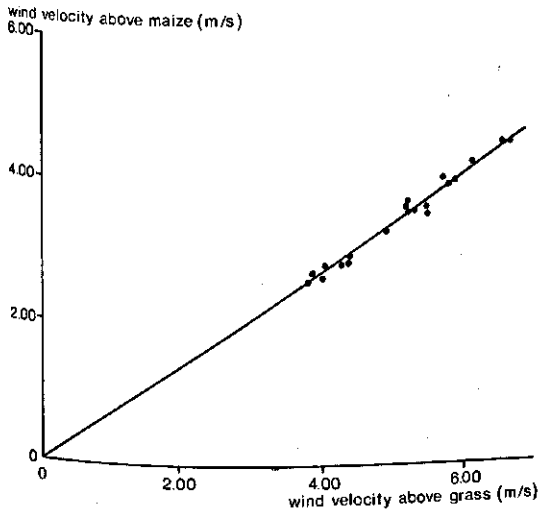

Fig. 49. Mean wind velocity above maize (Mast 1) 2.50 m above zero-plane displacement plotted against mean wind velocity above grass (Plot 9) 2.50 m above ground in 1976:
 $u_{\text{maize}} = 0.67 u_{\text{grass}}$

These results agree closely with the relationships when the estimated friction velocities above maize were plotted against the friction velocities above grass estimated from the wind profiles. Figures 50 and 51 show that from the measurements

$$\begin{aligned} u_{*,\text{maize}} &\approx 1.43 u_{*,\text{grass}} && \text{in 1975} \\ u_{*,\text{maize}} &\approx 1.74 u_{*,\text{grass}} && \text{in 1976} \end{aligned} \quad (51)$$

The friction velocity for maize plotted in these figures was estimated by the method described in Section 6.2.4, so that these values were corrected by about 5% for the over-estimation. If this correction is not made, the estimates of u_* increase by about 5%. Then the relationships derived from Figure 50 and Figure 51 (Eq. 51) become

$$\begin{aligned} u_{*,\text{maize}} &\approx 1.50 u_{*,\text{grass}} && \text{in 1975} \\ u_{*,\text{maize}} &\approx 1.83 u_{*,\text{grass}} && \text{in 1976} \end{aligned} \quad (52)$$

and these relationships agree with Equation 50.

Much more important than the relationships mentioned above is a relationship between wind velocity above grass, \bar{u}_{grass} , at a certain height and friction velocity above maize, $u_{*,\text{maize}}$. If such a general relationship could be derived, the friction velocity above maize could be directly estimated from routine wind-velocity measurements at a weather station.

If

$$\bar{u}_{\text{maize}} \approx 0.7 \bar{u}_{\text{grass}} \quad (\text{from Equation 47})$$

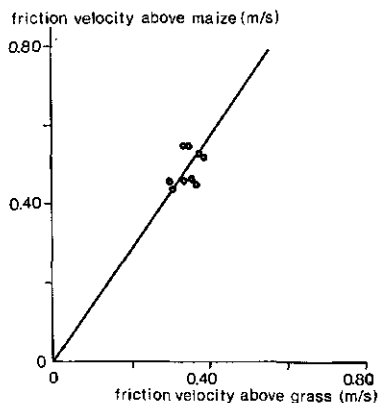

Fig. 50. Friction velocity above maize (Mast 1) plotted against friction velocity above grass (Plot 10) in 1975: $u_{*,\text{maize}} = 1.43 u_{*,\text{grass}}$.

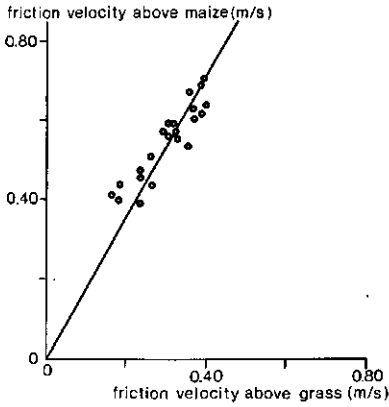

Fig. 51. Friction velocity above maize (Mast 1) plotted against friction velocity above grass (Plot 9) in 1976: $u_{*,\text{maize}} \approx 1.74 u_{*,\text{grass}}$.

and

$$u_{*,\text{maize}} \approx 0.16 \bar{u}_{\text{maize}} \quad (\text{from Equation 49})$$

a first approximation gives

$$u_{*,\text{maize}} \approx 0.11 \bar{u}_{\text{grass}} \quad (53)$$

where \bar{u}_{grass} was measured at 2.50 m above ground.

Figure 52 shows friction velocity above maize calculated from Equation 53 plotted against friction velocity derived from the measurements above maize by the method described in Section 6.2.4. For a reliable comparison these latter values of friction velocity had to be increased by about 5% (Sect. 6.5). So the relationship $u_{*,\text{calc}} \approx 1.06 u_{*,\text{meas}}$ derived from Figure 52 shows that $u_{*,\text{maize}}$ could be deduced reasonably well from the wind velocity above grass by Equation 53. After correction of $u_{*,\text{meas}}$, the relationship $u_{*,\text{calc}} \approx 1.06 u_{*,\text{meas}}$ turns to $u_{*,\text{calc}} \approx u_{*,\text{maize}}$ where $u_{*,\text{maize}}$ is the actual friction velocity above maize.

The relationships depend on height of measurement, roughness length and zero-plane displacement. The important role of roughness length of grass on the ratios of these quantities appears from the different relationships for Plot 9 (1976) and Plot 10 (1975). So the roughness length should be exactly known for a good estimate of \bar{u} and u_* above a certain crop deduced from one single measurement of the wind velocity above grass.

Also some requirements about the height of measurement must be met. Relationships like Equations 47 and 48 apply only if wind velocity is measured at a height within the adapted layer. Usually this requirement is not met for small fields.

To extrapolate the data of a weather station to another crop, knowledge of the air flow in the transition zone after a change in surface roughness is essential. In the present state of knowledge, a rule of thumb cannot be given, even when good estimates of

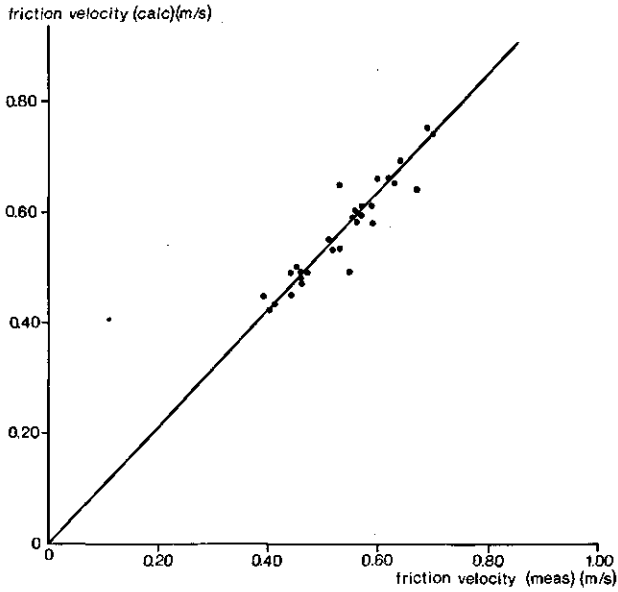

Fig. 52. Friction velocity above maize calculated from $u_{* \text{maize}} = 0.112 \bar{u}_{\text{grass}}$ plotted against the friction velocity derived from the measurements above maize: $u_{*, \text{calc}} \approx 1.06 u_{*, \text{meas}}$.

roughness lengths of different crops are known. Ditches, fences and zero-plane displacements disturb the development of the adapted layer. Knowledge about the influence of such factors on the adapted layer is necessary for reliable extrapolation of the data collected at a weather station.

8 Final discussion and conclusions

8.1 THICKNESS OF THE ADAPTED LAYER

For practical purposes, the well known rule of thumb for the ratio between the thickness of the adapted layer and the fetch $\delta(x)/x = 1/100$. The experiments discussed in this report have shown that, in a neutral or near-neutral atmosphere, this rule of thumb is safe when applied to the change in surface roughness between grassland and a maize field. From wind-profile measurements at two or three masts, a ratio $\delta(x)/x = 1/64$ was found for this experimental maize field.

Although the ratio between thickness of the adapted layer and fetch is no more than an estimate, this ratio leads to a considerably larger adapted layer than would follow from the rule of thumb $\delta(x)/x = 1/100$. However for tall crops like maize, for which a zero-plane displacement has to be taken into account, the benefit of the larger ratio $\delta(x)/x = 1/64$ is partly neutralized by the height of the crop (h). Part of the adapted layer, that is assumed to develop above the fictitious zero-plane (d), lies within the crop ($d < h$). So the layer suitable for profile measurements, the measuring layer, is smaller than the complete thickness of the adapted layer.

8.2 ESTIMATE OF d , z_0 AND u_* FROM WIND-PROFILE MEASUREMENTS ABOVE MAIZE

The parameters d , z_0 and u_* could not be estimated sufficiently accurately from the results of the wind-profile measurements above maize for a reliable estimate of transport of momentum. This has to be concluded from the results of the wind-profile measurements, despite the high requirements imposed on the crop, on equipment and its arrangement, and on weather conditions. Though the experimental field was situated in a flat polder and was extraordinarily large by Dutch standards, the fetch was not large enough to build up a sufficiently thick measuring layer.

As a consequence of too thin a measuring layer in the 1975 experiment, often only three heights of measurement could be used to estimate d , z_0 and u_* . Then small discrepancies, caused, for instance, by too small a fetch, or errors of measurement played an important role in the estimate of d and z_0 . In the 1976 experiment, the difference in height between the successive sensors was decreased and so more heights of measurement could be used. However then, the estimation of d and z_0 was again highly affected by errors of measurement, because the total range of the logarithmic profile above the maize crop, of course, did not increase. Consequently regression analysis by the method of least squares resulted for both 1975 and 1976 in estimates of d ranging from below the soil surface to above crop height.

The results obtained by application of the *modified* method of least squares, intro-

duced in this research and with some presumptions on zero-plane displacement and roughness length, were much better. This method still led to an inaccuracy in the estimate of d of $\pm 20\%$ for the 1975 experiment and of $\pm 25\%$ for the 1976 experiment. The inaccuracies in the estimate of z_0 were much larger (up to $\pm 35\%$). Though such inaccuracies in the estimate of d and z_0 implied a considerable improvement, compared with results obtained by the method of least squares, they are still too large to produce an accurate estimate of u_* . The estimate of the parameters d , z_0 and u_* will be improved only if, besides the number of heights of measurement, the range of the logarithmic wind profile also increases.

8.3 WIND-PROFILE AND EDDY-CORRELATION MEASUREMENTS

For the present maize crop, a sufficiently accurate estimate of d and z_0 could be derived from comparison of the results of simultaneously taken wind-profile measurements and eddy-correlation measurements. With the assumption that the ratio $c_e = u_* / \bar{V}_h$ derived from the eddy-correlation measurements is also valid for the wind-profile measurements, an acceptable estimate of d , z_0 and u_* was obtainable.

For a crop height of 2.60 m (1975), $d = 1.49 \pm 0.15$ m and $z_0 = 0.20 \pm 0.03$ m; and for a crop height of 2.10 m (1976) $d = 1.16 \pm 0.14$ m and $z_0 = 0.19 \pm 0.02$ m. When d and z_0 are expressed in relation to crop height, it follows that $d \approx (0.55 - 0.57) h$ and $z_0 \approx (0.08 - 0.09) h$.

In the combination of these two methods to estimate d , z_0 and u_* , the ratio c_e was used instead of c ($= u_* / \bar{u}$), and $c_p = u_{*,p} / \bar{u}_p$ was assumed to be equal to c_e . So for estimation of the parameters, a correction of only about 5% for the overestimation of wind velocity measured with cup-anemometers was already taken into account. The actual overestimation, however, appeared to be 12%. By allowing for this latter effect, the friction velocity derived from the profile measurements ($u_{*,p}$) would increase about 5%, zero-plane displacement would decrease about 14% and roughness length would increase about 23%. So the friction velocity obtained in this way will overestimate the actual friction velocity also by about 12%. When these final estimates of d and z_0 were expressed in relation to crop height, it followed that $d = 0.5 h$ and $z_0 = 0.11 h$.

8.4 HOMOGENEITY

With the assumption that u_* has the same value over the whole site of measurement, a different d is found from the comparison of wind-profile measurements simultaneously taken at two identical masts with eddy-correlation measurements. This difference in d amounts to 8% in 1975 and 11% in 1976.

As a consequence of the method used for estimating d , z_0 and u_* , a difference in d , with a constant u_* , could also be interpreted as a difference in u_* with the same d . Then the difference in u_* should amount to about 4% in 1975 and to about 6% in 1976. A difference in u_* over the field, however, means that the air flow is not homogeneous. A difference in u_* , and so this inhomogeneity could be caused by a small fetch together with a small difference in fetch between the two masts. This result shows, however, that under these conditions one should take into account a systematic uncertainty of at least 4 - 6%

in u_* , if u_* be estimated from measurements taken at one point that is assumed representative for the whole field.

8.5 THE RATIO d/h

The results of the present experiment show that the zero-plane displacement of the maize crop equals half the crop height. In the literature, several estimates of the ratio d/h for maize have been published. These estimates vary from 0.5 (Lemon & Wright, 1969; Stanhill, 1969) to 0.9 (Maki, 1969). With these data, it is well-nigh impossible to formulate a general empirical estimate of d/h for maize. The cause of these different estimates found in the literature cannot be exactly given. Information about experimental data in the literature is often insufficiently precise.

As shown again in this research, for practical reasons, the estimation of an accurate zero-plane displacement from wind-profile measurements is very difficult or even impossible. This might be a contributory cause to the great variety of estimates of d/h , apart from such factors as weather, climate, crop structure, crop density and too small a fetch.

If for practical application, the wind profile method is preferred for an estimate of the transport of momentum, then an empirical relationship for an estimate of d is needed. Based on the present results, the relationship $d = 0.5 h$ is recommended for a similar maize crop as the present and for weather usual in the Netherlands.

In the literature, several empirical relationships are suggested like $d = 0.64 h$ as recommended by Cowan (1968) or $d = 0.63 h$ according to Monteith (1973). These relationships are valid for several tall types of vegetation. When applied to special situations like in the present research, these relationships may result, however, in considerable systematic deviations in the estimates of z_0 and u_* . To illustrate this, the relationship $d = 0.6 h$ is introduced in the present measurements. Comparing the results obtained with the empirical relationship $d = 0.6 h$, with the results derived in the present research with $d = 0.5 h$, one can observe a systematic deviation of about 10% in u_* and 30 - 40% in z_0 .

If there is such a reliable empirical relationship, the application of the profile method has the advantage that the number of heights of measurement can be reduced. In principle not more than two heights of measurement are needed to estimate z_0 and u_* . Then it is easier to take all measurements within the adapted layer and also the difference in height between the sensors can be increased to reduce the risk of mutual interference of the sensors.

If also roughness length be estimated from a reliable empirical relationship, the profile method can be further simplified and then wind velocity at only one height is needed. However when wind velocity is measured at only one height, larger errors in the estimate of u_* may occur, by the introduction of an empirical relationship for d as well as for z_0 . These errors have to be added to errors resulting from overestimation of wind velocity measured with cup-anemometers. In general for this overestimation, a correction of about 10% will be sufficient.

8.6 A FLUCTUATING ZERO-PLANE DISPLACEMENT

The results of the present measurements show a considerable variation of the zero-plane displacement derived from successive runs. Keeping this in mind and considering the variety in the estimates of d/h in the literature, one may wonder how far the application of a fixed zero-plane displacement is allowed and how far zero-plane displacement will have a physical meaning. These questions should be investigated closer.

The present measurements also show that in general the wind profile above a grass surface can be described very well with the logarithmic model. Difficulties arise, however, when the zero-plane displacement cannot be neglected and has to be estimated from the measurements. Besides systematic deviations when an empirically derived zero-plane displacement is used, random errors will strongly influence the estimate of the actual u_* from run to run.

More difficulties will arise, when this model is applied to temperature profiles. It is not certain that the zero-plane displacement for the temperature profile is equal to the zero-plane displacement for the wind profile. When the zero-plane displacement for the temperature profile is not known, this interpretation remains questionable.

To estimate the transport of heat from simultaneously taken measurements of wind and temperature profiles, knowledge also of the physical meaning of the variation in zero-plane displacement of successive runs should be essential. Moreover the consequences of a fixed or empirical zero-plane displacement for wind as well as for temperature profiles should be studied.

Small fields have only a slightly developed adapted layer and measurements have thus to be taken in a transition layer, so that relationships between wind velocities cannot be predicted without more knowledge about the development of air flow over a surface with several changes in surface roughness.

8.7 RESULTS FROM MEASUREMENTS ABOVE GRASS AND MAIZE

A comparison of wind-profile measurements taken simultaneously above maize and above grass upstream of the maize field shows an empirical relationship between the representative wind velocities:

$$\begin{aligned}\bar{u}_{\text{maize}} &= 0.70 \bar{u}_{\text{grass}} && \text{for 1975} \\ \bar{u}_{\text{maize}} &= 0.67 \bar{u}_{\text{grass}} && \text{for 1976}\end{aligned}$$

The wind velocities \bar{u}_{maize} were taken 2.50 m above zero-plane displacement and \bar{u}_{grass} 2.50 m above ground. These relationships, however, depend closely on height of measurement and on the parameters d and z_0 . Present knowledge about the development of the internal boundary layer is insufficient to calculate \bar{u}_{maize} from measurements of \bar{u}_{grass} , only applying the crop parameters d and z_0 .

As a first approach, an estimate of the relationship between friction velocity above maize and wind velocity above grass can be deduced from the present measurements. With

the relations $\bar{u}_{\text{maize}} \approx 0.7 \bar{u}_{\text{grass}}$ and $u_{*,\text{maize}} \approx 0.16 \bar{u}_{\text{maize}}$, derived from the measurements, it follows $u_{*,\text{maize}} \approx 0.11 \bar{u}_{\text{grass}}$. The friction velocities above maize calculated by this relationship agreed within 2% with the friction velocities estimated directly from the measurements. However, too many empirical assumptions have to be made for this relationship to be advocated for practical purposes. Moreover (especially in the Netherlands), there are often large ditches or fences between successive (small) fields with different surface roughnesses. Then one needs to know which parameters, like roughness length, to introduce. Especially for small fields, such changes in roughness length play an important role. Unfortunately only little attention has been paid to that aspect.

Summary

The first aim of this study was to investigate if in practical research the profile method could be used to determine the turbulent transport of momentum, heat and water vapour between a maize crop and the atmosphere. Secondly an effort was made to deduce this vertical transport above a crop from routine measurements at a weather station. For these purposes, the logarithmic model for the vertical distribution of the wind velocity above a surface was assumed to be valid.

This research was part of a larger micrometeorological project that was performed by the Department of Physics and Meteorology of the Agricultural University in Wageningen. This project was done in 1974, 1975 and 1976 at the Experimental Station of the Agricultural University the Ir. A.P. Minderhoudhoeve near Swifterbant in East Flevoland. Measurements were taken in a maize field 320 m x 320 m and in a grassland plot upwind of the maize field.

Because the wind profile played a major role in estimation of vertical transport of momentum, heat and water vapour, much attention was paid to the arrangement and equipment for wind-profile measurements and the conditions of successful measurement in practical circumstances.

The results of the wind-profile measurements showed that the thickness of the adapted layer was larger than the rule of thumb often used for the ratio between thickness of the adapted layer $\delta(x)$ and fetch x : $\delta(x)/x = 1/100$ would indicate. The mean ratio $\delta(x)/x$ was $1/64$ for the present maize crop. This means that the thickness of the adapted layer equals on average $1/64$ times the fetch over the field. However for tall crops, part of this adapted layer lies within the crop and therefore the part of the adapted layer that is available for measurements is smaller than the thickness of the adapted layer would suggest.

Estimation of the parameters of the logarithmic model, d , z_0 and u_* from wind-profile measurements above a tall crop is very difficult. It proved even impossible to estimate the parameters from wind-profile measurements sufficiently accurately for practical purposes by a graphical method or by regression analysis. The modified method of least squares, introduced in this report, gave better results, but still did not lead to acceptable estimates of d , z_0 and u_* . Although measurements were taken in a field that was extraordinarily large by Dutch standards and that was situated in the flat polder, the difficulty of obtaining acceptable results was probably caused by a small fetch and consequently too thin a measuring layer.

However from a comparison of wind-profile measurements, and simultaneous eddy-correlation measurements, the parameters could be reliably estimated. If the mean zero-plane displacement and the mean roughness length were expressed in relation to crop height h , $d = 0.5 h$ and $z_0 = 0.11 h$. In the range of measured wind velocities (2 - 8 m/s) the zero-

plane displacement and the roughness length did not depend on wind velocity. Comparison with the results from eddy-correlation measurements showed also that cup-anemometers overestimated mean wind velocity by about 12%.

Measurements taken at several positions in the field showed that the air flow over the field was slightly inhomogeneous. This was probably caused by a small fetch and small differences in fetch at the two masts. Consequently for measurements at only one single mast, one may expect a systematic proportional error of u_* of 4 - 6%.

Moreover the use of empirical relationships between crop parameters for the estimation of d taken from the literature may lead to considerable systematic error for a maize crop like the present.

The wind profile above grass fitted the logarithmic wind profile well. The parameters z_0 and u_* could be pretty well estimated by the graphical method. To estimate vertical transport above maize from wind velocity above a grass surface, more knowledge is needed about the development of the adapted layer and about the transitional layer. Height of measurement, roughness length and zero-plane displacement influence the empirical relationships between the aerodynamic parameters to a high degree.

Especially in agricultural research with small fields, where the thickness of the adapted layer will be small, more knowledge is needed about the transitional layer and about the parameters that should be introduced.

Samenvatting

Doel van dit onderzoek was na te gaan of de profielmethode bruikbaar is voor de bepaling van de turbulente uitwisseling van impuls, warmte en vocht tussen gewas en atmosfeer in praktijkgericht onderzoek. Tevens is onderzocht of de turbulente uitwisseling boven een maisgewas geschat kon worden uit waarnemingen van de windsnelheid boven een naastliggend perceel grasland. De geldigheid van het logaritmische model voor de verticale verdeling van de windsnelheid boven een oppervlak is hierbij als uitgangspunt genomen.

Het onderzoek maakte deel uit van een groter micrometeorologisch onderzoek verricht door de afdeling Natuur- en Weerkunde van de Landbouwhogeschool. Dit project werd uitgevoerd in de jaren 1974, 1975 en 1976 op het proefbedrijf van de Landbouwhogeschool, de 'Ir. A.P. Minderhoudhoeve' te Swifterbant in Oostelijk Flevoland. Metingen zijn verricht op een 10 ha groot maisveld en op een windopwaarts van dit veld gelegen perceel grasland.

Daar in dit onderzoek het windprofiel centraal stond bij de bepaling van de turbulente uitwisseling van impuls, warmte en vocht, lag de nadruk op opzet en uitvoering van deze windprofielmetingen. Veel aandacht is besteed aan de eisen waaraan moet worden voldaan om in praktijkomstandigheden succesvolle profielmetingen te kunnen doen.

De resultaten van de windprofielmetingen tonen aan dat de vuistregel voor de verhouding tussen de dikte van de aangepaste grenslaag en de aanstrijk lengte $\delta(x)/x = 1/100$, voor dit maisgewas een te strenge eis is. Uit de metingen kon worden afgeleid dat voor deze situatie de verhouding $\delta(x)/x$ gemiddeld $1/64$ bedroeg. Dit betekent dat de dikte van de aangepaste grenslaag gemiddeld gelijk is aan $1/64$ -ste deel van de aanstrijk lengte over het gewas. Bij hoge gewassen bevindt een gedeelte van deze aangepaste grenslaag zich echter in het gewas. Het voor metingen beschikbare deel, de meetlaag, is derhalve kleiner dan verwacht zou worden op grond van de gevonden verhouding $\delta(x)/x$.

Uit dit onderzoek volgt nog eens dat het bij een hoog gewas zeer moeilijk is om de parameters van het logaritmische model, d , z_0 en u_* , te bepalen uit windprofielmetingen boven het gewas. Het bleek zelfs onmogelijk om, gebruikmakend van een grafische methode of van een regressie-analyse volgens de methode van de kleinste kwadraten, deze parameters met voor praktisch onderzoek voldoende nauwkeurigheid te schatten uit profielmetingen alleen. De in dit proefschrift geïntroduceerde gewijzigde methode van de kleinste kwadraten, waarbij verschillende vaste waarden van de nulvlaksverplaatsing werden aangenomen, leverde weliswaar betere resultaten op, maar nog altijd niet voldoende nauwkeurig. Hoewel de metingen zijn verricht op een voor Nederlandse omstandigheden buitengewoon groot veld, gelegen in een vlak polderlandschap is blijkbaar toch de aanstrijk lengte nog niet groot genoeg en dientengevolge de dikte van de meetlaag te gering.

Door de gegevens van de windprofielmetingen te vergelijken met de gegevens van gelijktijdig verrichte eddy-correlatiemetingen, was het wel goed mogelijk de parameters te bepalen. Uitgedrukt in de hoogte van het gewas h wordt voor de gemiddelde nulvlaksver-

plaatsing d gevonden $d = 0.5 h$ en voor de gemiddelde ruweidslengte $z_0 = 0.11 h$. Uit vergelijking met de resultaten van de eddy-correlatie methode kon verder worden afgeleid dat de gemiddelde windsnelheid bij meting met cup-anemometers werd overschat met ongeveer 12%. Een afhankelijkheid van de parameters d en z_0 van de gemiddelde windsnelheid was niet aantoonbaar in het traject waarin de metingen plaatsvonden (2 - 8 m/s).

Voorts is aangetoond dat het gebruik van empirische relaties ter schatting van de nulvlaksverplaatsing tot aanzienlijke systematische fouten kan leiden voor een gewas als dit onder vergelijkbare omstandigheden.

Uit metingen verricht op verschillende plaatsen in het veld, bleek dat de luchtstroming over het veld niet geheel homogeen was, waarschijnlijk een gevolg van een kleine aanstrijk lengte en geringe verschillen in aanstrijk lengte bij verschillende masten. Bij een onderzoek als hier beschreven moet men daarom bij meting op slechts één plaats rekening houden met een mogelijke systematische afwijking van 4 - 6% in u_* .

Voor het beschrijven van het windprofiel boven gras bleek het logaritmische model goed te voldoen. Met de grafische methode konden de parameters z_0 en u_* voor gras goed worden geschat. Om de turbulente uitwisseling boven mais te schatten uit de windsnelheid boven gras bleek echter een uitgebreide kennis van grenslaagopbouw en grenslaagovergangen noodzakelijk. Meethoogte, ruweidslengte en nulvlaksverplaatsing blijken van grote invloed op de onderlinge verhouding van de aerodynamische grootheden boven de verschillende gewassen. Vooral voor de praktijk, waarin men veelal te maken zal hebben met kleine velden zodat de dikte van de aangepaste grenslaag zeer gering is, is meerdere kennis omtrent grenslaagovergangen en in te voeren ruweidsparementen onmisbaar.

References

- Allen, L.H., Jr., 1968. Turbulence and wind speed spectra within a Japanese larch plantation. *J. Appl. Meteorol.* 7: 73-78.
- Bernstein, A.B., 1966. An examination of three wind profile hypotheses. *J. Appl. Meteorol.* 5: 217-219.
- Bernstein, A.B., 1967. A note on the use of cup anemometers in wind profile experiments. *J. Appl. Meteorol.* 6: 280-286.
- Biscoe, P.V., J.A. Clark, K. Gregson, M. McGowan, J.L. Monteith & R.K. Scott, 1975. Barley and its environment. I. Theory and practice. *J. Appl. Ecol.* 12: 227-247.
- Blom, J. & L. Wartena, 1969. The influence of changes in surface roughness on the development of the turbulent boundary layer in the lower layers of the atmosphere. *J. Atmos. Sci.* 26: 255-265.
- Boer-Waanders, A.G. de, 1972. Verticale profielen en transportprocessen in de oppervlaktengrens laag gewas-atmosfeer. Intern. Rep. 1972-2, Lab. of Phys. and Meteorol., Agric. Univ. Wageningen. 60 pp. (in Dutch).
- Bottemanne, F.A., 1977a. Test van een eenvoudige hitte-kruisdraad anemometer. Eddy-correlatie metingen boven mais. Intern. Rep., Lab. of Phys. and Meteorol., Agric. Univ. Wageningen. 31 pp. (in Dutch).
- Bottemanne, F.A., 1977b. Eddy-correlation measurements above a maize crop applying a simple hot cross-wire anemometer. (accepted by *Agric. Meteorol.*).
- Bradley, E.F., 1968. A micrometeorological study of velocity profiles and surface drag in the region modified by a change in surface roughness. *Q. J. R. Meteorol. Soc.* 94: 361-379.
- Businger, J.A., J.C. Wyngaard, Y. Izumi & E.F. Bradley, 1971. Flux-profile relationships in the atmospheric surface layer. *J. Atmos. Sci.* 28: 181-189.
- Charnock, H., 1967. Flux-gradient relations near the ground in unstable conditions. *Q. J. R. Meteorol. Soc.* 93: 97-100.
- Covey, W., 1963. A method for the computation of logarithmic wind profile parameters and their standard errors. In: The energy budget at the earth's surface. Part II. Prod. Res. Rep. No. 72. Agric. Res. Serv., U. S. Dep. Agric. Prep. by E.R. Lemon: 28-33.
- Cowan, I.R., 1968. Mass, heat and momentum exchange between stands of plants and their atmospheric environment. *Q. J. R. Meteorol. Soc.* 94: 523-544.
- Dabberdt, W.F., 1968. Tower-induced errors in wind profile measurements. *J. Appl. Meteorol.* 7: 359-366.
- De Boer-Waanders, A.G., 1972. Verticale profielen en transportprocessen in de oppervlaktengrens laag gewas-atmosfeer. Intern. Rep. 1972-2, Lab. of Phys. and Meteorol., Agric. Univ. Wageningen. 60 pp. (in Dutch).
- Dyer, A.J., 1963. The adjustment of profiles and eddy fluxes. *Q. J. R. Meteorol. Soc.* 89: 276-280.
- Echols, W.T. & N.K. Wagner, 1972. Surface roughness and internal boundary layer near a coastline. *J. Appl. Meteorol.* 11: 658-662.
- Elliott, W.P., 1958. The growth of the atmospheric internal boundary layer. *Trans. Am. Geophys. Union* 39: 1048-1054.
- Fritschen, L.J., 1967. A sensitive cup-type anemometer. *J. Appl. Meteorol.* 6: 695-698.
- Gill, G.C., L.E. Olsson, J. Sela & M. Suda, 1967. Accuracy of wind measurements on towers or stacks. *Bull. Am. Meteorol. Soc.* 48: 665-674.
- Goudriaan, J., 1977. Crop micrometeorology: a simulation study. Doctoral thesis. Pudoc Wageningen. 249 pp.
- Guyot, G., 1969. Diffusion turbulente au-dessus et à l'intérieur d'un couvert végétal: Application à l'étude des flux de chaleur et de masse. *La Houille Blanche* 4: 345-352.
- Hicks, B.B., P. Hyson & C.J. Moore, 1975. A study of eddy fluxes over a forest. *J. Appl. Meteorol.* 14: 58-66.
- Hyson, P., 1972. Cup anemometer response to fluctuating wind speeds. *J. Appl. Meteorol.* 11: 843-848.
- Izumi, Y. & M.L. Barad, 1970. Wind speeds as measured by cup and sonic anemometers and influenced by tower structure. *J. Appl. Meteorol.* 9: 851-856.

- Kalma, J.D. & G. Stanhill, 1972. The climate of an orange orchard: Physical characteristics and microclimate relationships. *Agric. Meteorol.* 10: 185-201.
- Kawatani, T. & R.N. Meroney, 1970. Turbulence and wind speed characteristics within a model canopy flow field. *Agric. Meteorol.* 7: 143-158.
- Klaassen, W., 1976a. Korrelatie metingen met de propeller-bivaan. Intern. Rep., Lab. of Phys. and Meteorol., Agric. Univ. Wageningen. 66 pp. (in Dutch).
- Klaassen, W., 1976b. IJking van de windtunnel met de laser-dopplersnelheidsmeter. Intern. Rep., Lab. of Phys. and Meteorol., Agric. Univ. Wageningen. 25 pp. (in Dutch).
- Kondo, J., 1971. Relationship between the roughness coefficient and other aerodynamic parameters. *J. Meteorol. Soc. Japan* 49: 121-124.
- Legg, B.J. & I.F. Long, 1975. Turbulent diffusion within a wheat canopy: II. Results and interpretation. *Q. J. R. Meteorol. Soc.* 101: 611-628.
- Lemon, E.R. & J.L. Wright, 1969. Photosynthesis under field conditions. XA. Assessing sources and sinks of carbon dioxide in a corn (*Zea mays* L.) crop using a momentum balance approach. *Agron. J.* 61: 405-411.
- Lemon, L., D.W. Stewart & R.W. Shawcroft, 1971. The sun's work in a cornfield. *Science* 174: 371-378.
- Lettau, H., 1959. A review of research problems in micrometeorology. Dep. Meteorol. Univ. of Wisconsin. (Final Rep. Contract DA-36-039SC-80063) (cited by Tanner, 1963).
- Lettau, H., 1969. Note on aerodynamic roughness-parameter estimation on the basis of roughness-element description. *J. Appl. Meteorol.* 8: 828-832.
- Lumley, J.L. & H.A. Panofsky, 1964. The structure of atmospheric turbulence. Interscience Publishers, New York. 239 pp.
- MacCreedy, P.B., Jr., 1966. Mean wind speed measurements in turbulence. *J. Appl. Meteorol.* 5: 219-225.
- Maki, T., 1969. On zero-plane displacement and roughness length in the wind velocity profile over a corn canopy. *J. Agric. Meteorol. (Tokyo)* 25: 13-18.
- Maki, T., 1975. Interrelationships between zero-plane displacement, aerodynamic roughness length and plant canopy height. *J. Agric. Meteorol. (Tokyo)* 31: 7-15 (in Japanese).
- McBean, G.A., 1972. Instrument requirements for eddy-correlation measurements. *J. Appl. Meteorol.* 11: 1078-1084.
- McCaughey, J.H. & J.A. Davies, 1975. Energy exchange in a corn canopy. *Can. J. Plant Sci.* 55: 691-704.
- McVehil, G.E., 1964. Wind and temperature profiles near the ground in stable stratification. *Q. J. R. Meteorol. Soc.* 90: 136-146.
- Monin, A.S. & A.M. Obukhov, 1954. Fundamentale Gesetzmäßigkeiten der turbulenten Vermischung in der bodennahen Schicht der Atmosphäre. Sammelband zur statistischen Theorie der Turbulenz. Akad. Verlag Berlin 1958: 199-226. (German translation from the Russian in *Geophys. Inst. Acad. Sci. USSR* 24 (151): 163-187).
- Monteith, J.L., 1973. Principles of environmental physics. E. Arnold, London, 241 pp.
- Moses, H. & H.G. Daubek, 1961. Errors in wind measurements associated with tower-mounted anemometers. *Bull. Am. Meteorol. Soc.* 42: 190-194.
- Mukammal, E.I., K.M. King & H.F. Cork, 1966. Comparison of aerodynamic and energy budget techniques in estimating evapotranspiration from a cornfield. *Arch. Meteorol. Geophys. Bioklimatol.*, Ser. B, Band 14: 384-395.
- Munn, R.E., 1966. Descriptive micrometeorology. Acad. Press, New York. 245 pp.
- Munro, D.S. & T.R. Oke, 1973. Estimating wind profile parameters for tall dense crops. *Agric. Meteorol.* 11: 223-228.
- Munro, D.S. & T.R. Oke, 1975. Aerodynamic boundary-layer adjustment over a crop in neutral stability. *Boundary Layer Meteorol.* 9: 53-61.
- Nkemdirim, L.C., 1974. Windshear, temperature gradient, and eddy diffusivity over growing crop. *Arch. Meteorol. Geophys. Bioklimatol.*, Ser. A, 23: 65-76.
- Nickerson, E.C., 1968. Boundary layer adjustment as an initial value problem. *J. Atmos. Sci.* 25: 207-213.
- Oliver, H.R., 1971. Wind profiles in and above a forest canopy. *Q. J. R. Meteorol. Soc.* 97: 548-553.
- Oosterum, M.A.M. van, 1977. Eddy-correlatie metingen boven mais. Intern. Rep., Lab. of Phys. and Meteorol., Agric. Univ. Wageningen. 98 pp. (in Dutch).
- Panofsky, H.A. & E.L. Petersen, 1972. Wind profiles and change of terrain roughness at Risø. *Q. J. R. Meteorol. Soc.* 98: 845-854.
- Panofsky, H.A. & A.A. Townsend, 1964. Change of terrain roughness and the wind profile. *Q. J. R. Meteorol. Soc.* 90: 147-155, and 91: 240-242.
- Penman, H.L. & I.F. Long, 1960. Weather in wheat: an essay in micrometeorology. *Q. J. R. Meteorol. Soc.* 86: 16-50.

- Petersen, E.L. & P.A. Taylor, 1973. Some comparisons between observed wind profiles at Risø and theoretical predictions for flow over inhomogeneous terrain. Q. J. R. Meteorol. Soc. 99: 329-336.
- Peterson, E.W., 1969. Modification of mean flow and turbulent energy by a change in surface roughness under conditions of neutral stability. Q. J. R. Meteorol. Soc. 95: 561-575.
- Peterson, E.W., 1972. Relative importance of terms in the turbulent-energy and momentum equations as applied to the problem of a surface roughness change. J. Atmos. Sci. 29: 1470-1476.
- Plate, E.J. & A.A. Quraishi, 1965. Modeling of velocity distributions inside and above tall crops. J. Appl. Meteorol. 4: 400-408.
- Randall, J.M., 1969. Wind profiles in an orchard plantation. Agric. Meteorol. 6: 439-452.
- Rao, K.S., 1975. Effect of thermal stratification on the growth of the internal boundary layer. Boundary Layer Meteorol. 8: 227-234.
- Rao, K.S., J.C. Wyngaard & O.R. Coté, 1974. The structure of the two-dimensional internal boundary layer over a sudden change of surface roughness. J. Atmos. Sci. 31: 738-746.
- Rider, N.E., 1960. On the performance of sensitive cup-anemometers. Meteorol. Mag. 89: 209-215.
- Rider, N.E., J.R. Philip & E.F. Bradley, 1963. The horizontal transport of heat and moisture - a micrometeorological study. Q. J. R. Meteorol. Soc. 89: 507-531, and 91: 236-240.
- Robinson, S.M., 1962. Computing wind profile parameters. J. Atmos. Sci. 19: 189-190.
- Rose, C.W., 1966. Agricultural physics. Pergamon Press, Oxford. 229 pp.
- Ruijschoot, J., 1976. Het meten van verticaal energietransport in de atmosferische oppervlaktegrenslaag met het fluxatron. Intern. Rep., Lab. of Phys. and Meteorol., Agric. Univ. Wageningen. 82 pp. (in Dutch).
- Sheppard, P.A., 1940. An improved design of cup anemometer. J. Sci. Instrum. 17: 218-221. (cited by Fritschen, 1967).
- Shir, C.C., 1972. A numerical computation of air flow over a sudden change of surface roughness. J. Atmos. Sci. 29: 304-310.
- Stanhill, G., 1969. A simple instrument for the field measurement of turbulent diffusion flux. J. Appl. Meteorol. 8: 509-513.
- Stanhill, G. & M. Fuchs, 1968. The climate of the cotton crop: Physical characteristics and microclimate relationships. Agric. Meteorol. 5: 183-202.
- Stearns, C.R., 1970. Determining surface roughness and displacement height. Boundary Layer Meteorol. 1: 102-111.
- Stigter, C.J., 1974. The epidermal resistance to diffusion of water vapour: an improved measuring method and field results in Indian corn (*Zea mays*). Agric. Res. Rep. 813. Pudoc Wageningen. 26 pp.
- Stigter, C.J. & A.D. Welgraven, 1976. An improved radiation protected differential thermocouple psychrometer for crop environment. Arch. Meteorol. Geophys. Bioklimatol. Ser. B 24: 177-188.
- Stigter, C.J., J.G. Lengkeek & J. Kooijman, 1976. A simple worst case analysis for estimation of correct scanning rate in a micrometeorological experiment. Neth. J. Agric. Sci. 24: 3-16.
- Sutton, O.G., 1953. Micrometeorology. McGraw-Hill, New York. 333 pp.
- Szeicz, G. & I.F. Long, 1969. Surface resistance of crop canopies. Water Resour. Res. 5: 622-633.
- Szeicz, G., G. Endrödi & S. Tajchman, 1969. Aerodynamic and surface factors in evaporation. Water Resour. Res. 5: 380-394.
- Tajchman, S.J., 1973. On vertical profiles of meteorological parameters above a layer of rough vegetation. J. Geophys. Res. 78 (27): 6381-6385.
- Tanner, C.B., 1963. Basic instrumentation and measurements for plant environment and micrometeorology. Soils Bulletin 6, Dep. of Soil Sci., Univ. of Wisconsin: AE 1-31; W 1-26.
- Tanner, C.B. & W.L. Pelton, 1960. Potential evapotranspiration estimates by the approximate energy balance method of Penman. J. Geophys. Res. 65: 3391-3413.
- Taylor, P.A., 1969. On wind shear stress profiles above a change in surface roughness. Q. J. R. Meteorol. Soc. 95: 77-91.
- Taylor, R.J., 1962. Small-scale advection and the neutral wind profile. J. Fluid Mech. 13: 529-539.
- Tennekes, H. & J.L. Lumley, 1972. A first course in turbulence. The M.I.T. Press, Cambridge, Mass. 300 pp.

- Thom, A.S., J.B. Stewart, H.R. Oliver & J.H.C. Gash, 1975. Comparison of aerodynamic and energy budget estimates of fluxes over a pine forest. Q. J. R. Meteorol. Soc. 101: 93-105.
- Townsend, A.A., 1965. The response of a turbulent boundary layer to abrupt changes in surface conditions. J. Fluid Mech. 22: 799-822.
- Udagawa, T., 1966. Variation of aerodynamical characteristics of a barley field with growth. J. Agric. Meteorol. (Tokyo) 22: 7-13.
- Van Oosterum, M.A.M., 1977. Eddy-correlatie metingen boven mais. Intern. Rep., Lab. of Phys. and Meteorol., Agric. Univ. Wageningen. 98 pp. (in Dutch).
- Voortman, D., 1976. Warmtestroommetingen in de grond. Intern. Rep., Lab. of Phys. and Meteorol., Agric. Univ. Wageningen. 39 pp. (in Dutch).
- Webb, E.K., 1970. Profile relationships: the log-linear range, and extension to strong stability. Q. J. R. Meteorol. Soc. 96: 67-90.
- Wright, J.L. & E.R. Lemon, 1966. Photosynthesis under field conditions. IX. Vertical distribution of photosynthesis within a corn crop. Agron. J. 58: 265-268.

Appendices

APPENDIX 1

Estimation of d , z_0 and u_ by regression analysis by the method of least squares (Robinson, 1962; Covey, 1963)*

The computing method is based on the existence of a logarithmic wind profile, which means that

$$\bar{u}_i = (u_*/k) \ln ((z_i - d)/z_0) \quad (\text{A1.1})$$

holds for any particular height. The application of the method of least squares means that the sum E of the squares of the differences between the measured wind velocities \bar{u}_i and the ideal wind velocities, which are equal to $(u_*/k) \ln ((z_i - d)/z_0)$, will be minimum. So the function

$$E = \sum_{i=1}^n \left[\bar{u}_i - (u_*/k) \ln ((z_i - d)/z_0) \right]^2 \quad (\text{A1.2})$$

is minimum, where n is the number of heights of measurement. From the need to minimize the function E , it follows that

$$\partial E / \partial u_* = -(2/k) \sum_{i=1}^n \left[\bar{u}_i - (u_*/k) \ln ((z_i - d)/z_0) \right] \cdot \left[\ln ((z_i - d)/z_0) \right] = 0 \quad (\text{A1.3})$$

$$\partial E / \partial d = 2 \sum_{i=1}^n \left[\bar{u}_i - (u_*/k) \ln ((z_i - d)/z_0) \right] \cdot \left[(u_*/k) (1/(z_i - d)) \right] = 0 \quad (\text{A1.4})$$

$$\partial E / \partial z_0 = 2 \sum_{i=1}^n \left[\bar{u}_i - (u_*/k) \ln ((z_i - d)/z_0) \right] \cdot \left[(u_*/k) / z_0 \right] = 0 \quad (\text{A1.5})$$

For simplicity, the following substitutions are introduced

$$\begin{aligned} w &= \ln z_0 & v_i &= \bar{u}_i - \bar{u} \\ x_i &= \ln (z_i - d) & r_i &= 1/(z_i - d) \\ \bar{x} &= \sum_{i=1}^n (x_i/n) & v_* &= u_*/k \\ y_i &= x_i - \bar{x} \end{aligned}$$

Then Equations A1.3, A1.4 and A1.5 turn to

$$\sum_{i=1}^n \left[(\bar{u}_i - v_*(x_i - w)) (x_i - w) \right] = 0 \quad (\text{A1.6})$$

$$v_* \sum_{i=1}^n \left[(\bar{u}_i - v_*(x_i - w)) x_i \right] = 0 \quad (\text{A1.7})$$

$$(v_*/z_0) \sum_{i=1}^n \left[\bar{u}_i - v_*(x_i - w) \right] = 0 \quad (\text{A1.8})$$

respectively.

From Equation A1.8 follows

$$n\bar{u} - nv_*\bar{x} + nv_*w = 0$$

and so

$$w = \bar{x} - \bar{u}/v_* \quad (\text{A1.9})$$

Substitution of Equation A1.9 in Equations A1.6 and A1.7 leads to

$$\overline{vy} - v_*\bar{y}^2 = 0 \quad (\text{A1.10})$$

and

$$\overline{vr} - v_*\bar{y}r = 0 \quad (\text{A1.11})$$

respectively. Finally these equations result in

$$\overline{vr}/\bar{y}r = \overline{vy}/\bar{y}^2 \quad \text{or} \quad (1/\bar{y}^2) - \overline{vr}/(\overline{vy} \bar{y}r) = 0 \quad (\text{A1.12})$$

Equation A1.12 is implicit in the single unknown d , which is to be solved. To find the desired value of d , a function

$$g(d) = 1/\bar{y}^2 - \overline{vr}/(\overline{vy} \bar{y}r) \quad (\text{A1.13})$$

is defined. For the desired d , $g(d) = 0$.

The root of the function $g(d)$ is approximated by iteration techniques (linear interpolation and bisection). The estimate of d is assumed to be sufficiently accurate when $|g(d)| < 10^{-4}/n$ where n is the number of heights of measurement. Usually the number of iterations is smaller than 10. When the number of iterations exceeds 20, the estimate of d , u_* and z_0 is written off, because then some of the data might be erroneous. When d is found, u_* and z_0 can be estimated from Equation A1.11

$$v_* = u_*/k = \overline{vr}/\overline{y^r} \quad (\text{A1.14})$$

and Equation A1.9

$$\ln z_0 = \bar{x} - \bar{u}/v_* \quad (\text{A1.15})$$

respectively.

Accuracy of the estimate of d by regression analysis with the method of least squares

For the fitting value of d ,

$$|g(d)| \leq 10^{-4}/n$$

To estimate the accuracy of the fitting value of d the differential $\partial g(d)/\partial d$ is calculated for $g(d) = 0$. This leads to

$$\frac{\partial g(d)}{\partial d_{g(d)=0}} = \frac{1}{y^2} \left[\frac{\overline{y^r^2}}{\overline{y^r}} - \frac{\overline{rs}}{\overline{y^r}} - \frac{\overline{vs}}{\overline{vy}} + \frac{\overline{2ys}}{y^2} - \frac{\overline{vr^2}}{\overline{vr}} \right] \quad (\text{A1.16})$$

where $s_i = r_i - \bar{r}$. This function depends on the value of d , \bar{u}_i and z_i .

To calculate this function, the data of 1976-08-14 Run 8 are introduced:

$z_1 = 3.10 \text{ m}$	$\bar{u}_1 = 2.90 \text{ m/s}$	$\bar{u} = 3.22 \text{ m/s}$
$z_2 = 3.40 \text{ m}$	$\bar{u}_2 = 3.08 \text{ m/s}$	
$z_3 = 3.70 \text{ m}$	$\bar{u}_3 = 3.24 \text{ m/s}$	
$z_4 = 4.00 \text{ m}$	$\bar{u}_4 = 3.38 \text{ m/s}$	
$z_5 = 4.30 \text{ m}$	$\bar{u}_5 = 3.50 \text{ m/s}$	

The estimate of d amounts to 1.373 m and $\partial g(d)/\partial d \approx 0.095$. The quantity $\partial g(d)/\partial d$ should be less or equal to $10^{-4}/5$. So $\partial d \approx 0.2 \text{ mm}$ when five heights of measurement are used and $\partial d \approx 0.4 \text{ mm}$ when only three heights are available. This deviation is small enough for an accurate estimate of d .

APPENDIX 2

Effect of errors of measurement on the estimate of zero-plane displacement

To find the effect of errors of measurement on the estimate of d (Covey, 1963), the effect of a small change in one of the measured wind velocities, $\Delta \bar{u}_i$, is considered. The zero-plane displacement is estimated by the function

$$g(d) = \frac{1}{y^2} - \frac{\overline{vr}}{\overline{vy} \overline{yr}}$$

depending on d and \bar{u}_i .

So the error in d can be estimated by

$$dg(d) = \frac{\partial g(d)}{\partial d} \Big|_{\bar{u}_1, \bar{u}_2, \dots, \bar{u}_n} dd + \sum_{i=1}^n \frac{\partial g(d)}{\partial \bar{u}_i} \Big|_{\bar{u}_{i \neq j}, d} d\bar{u}_i$$

Divide this equation by $d\bar{u}_1$ and put $0 = d\bar{u}_2 = d\bar{u}_3 = \dots = d\bar{u}_n = dg(d)$. This leads to

$$\frac{\partial g(d)}{\partial d} \cdot \frac{\partial d}{\partial \bar{u}_1} \Big|_{\bar{u}_2, \dots, \bar{u}_n} + \frac{\partial g(d)}{\partial \bar{u}_1} \Big|_{\bar{u}_2, \dots, \bar{u}_n, d} = 0 \quad \text{for } i = 1$$

or

$$\frac{\partial d}{\partial \bar{u}_1} \Big|_{\bar{u}_2, \bar{u}_3, \dots, \bar{u}_n, g(d)} = - \frac{\partial g(d) / \partial \bar{u}_1 \Big|_{\bar{u}_2, \dots, \bar{u}_n, d}}{\partial g(d) / \partial d \Big|_{\bar{u}_2, \dots, \bar{u}_n}} \quad (\text{A2.1})$$

The error in d is given by

$$E(d) = \frac{\partial d}{\partial \bar{u}_1} \cdot E(\bar{u}_1) + \frac{\partial d}{\partial \bar{u}_2} \cdot E(\bar{u}_2) + \dots + \frac{\partial d}{\partial \bar{u}_n} \cdot E(\bar{u}_n)$$

Suppose that $\Delta \bar{u}_1$ is the error of measurement of wind velocity \bar{u}_1 and $\Delta \bar{u}_2, \dots, \Delta \bar{u}_n = 0$. Then

$$\frac{\partial g(d)}{\partial \bar{u}_1} = \frac{\partial}{\partial \bar{u}_1} \left[\frac{1}{y^2} - \frac{\overline{vr}}{\overline{vy} \overline{yr}} \right] = \frac{1}{\overline{vy} \overline{yr}^2} \frac{y_1}{n} - \frac{1}{\overline{vr} \overline{yr}^2} \frac{s_1}{n}$$

and

$$\frac{\partial g(d)}{\partial d} = \frac{1}{\overline{y}^2} \left[\frac{\overline{yr}^2}{\overline{yr}} - \frac{\overline{rs}}{\overline{yr}} - \frac{\overline{vs}}{\overline{vy}} + \frac{2\overline{ys}}{\overline{y}^2} - \frac{\overline{vr}^2}{\overline{vr}} \right] \quad (\text{A1.16})$$

The error in d can be found from Equation A2.1

$$\frac{\Delta d}{\Delta \bar{u}_1} = - \frac{\partial g(d) / \partial \bar{u}_1}{\partial g(d) / \partial d}$$

With the example from Appendix 1 and $\Delta \bar{u}_1 = 5 \text{ mm/s}$, the error in d amounts to -0.14 m .

For $\Delta \bar{u}_2 = 5 \text{ mm/s}$ and $\Delta \bar{u}_i = 0$ for $i \neq 2$ $\Delta d = +0.10 \text{ m}$

$\Delta \bar{u}_3 = 5 \text{ mm/s}$ and $\Delta \bar{u}_i = 0$ for $i \neq 3$ $\Delta d = +0.13 \text{ m}$

$\Delta \bar{u}_4 = 5 \text{ mm/s}$ and $\Delta \bar{u}_i = 0$ for $i \neq 4$ $\Delta d = +0.03 \text{ m}$

$\Delta \bar{u}_5 = 5 \text{ mm/s}$ and $\Delta \bar{u}_i = 0$ for $i \neq 5$ $\Delta d = -0.13 \text{ m}$

A small error in one of the measured wind velocities causes a considerable error in the estimate of d . However in practice each of the measured wind velocities will have a certain error of measurement and this may lead to a smaller error in d than estimated in the example above.

APPENDIX 3

Zero-plane displacement estimated by the method of least squares
 . = no estimate after 20 iterations.

Run No.	Zero-plane displacement estimated from			Run No.	Zero-plane displacement estimated from		
	5	4	3		5	4	3
	heights of measurement (m)				heights of measurement (m)		
Mast 1, 1976-08-14							
3	0.26	.	.	9	0.65	1.90	1.44
4	0.50	.	1.64	10	.	.	.
5	1.25	1.53	1.94	11	.	-0.80	.
6	0.70	-0.72	1.14	12	-0.34	0.43	.
7	0.82	.	.	Mast 2, 1976-08-14			
8	1.37	1.11	0.85	3	-0.00	0.67	0.39
9	1.40	0.91	1.96	4	0.57	1.54	2.13
10	0.30	.	-2.21	5	0.41	0.24	2.23
11	1.32	0.94	1.54	6	1.16	1.75	2.09
Mast 1, 1976-08-15				7	0.79	.	1.74
4	0.77	1.25	2.14	8	1.27	1.74	.
5	0.49	.	0.84	9	0.65	0.99	1.86
6	-1.06	.	1.54	10	-0.19	1.38	1.59
7	0.32	0.02	1.96	11	1.41	1.77	-4.03
8	-0.41	.	1.54	Mast 2, 1976-08-15			
9	0.10	0.91	1.96	4	0.22	-0.26	2.11
10	0.49	.	0.55	5	1.24	1.54	2.13
11	-0.28	.	.	6	0.50	1.19	1.44
12	0.78	-0.45	.	7	1.06	1.53	1.99
Mast 1, 1976-08-19				8	.	1.07	1.68
1	0.17	0.46	1.74	9	.	-0.51	1.86
2	1.80	1.96	2.24	10	-0.13	1.57	2.26
3	-0.03	-4.95	.	11	1.32	1.80	1.79
4	0.90	0.74	.	12	-0.12	1.15	1.94
5	0.48	.	.	Mast 2, 1976-08-19			
6	-0.09	.	.	1	0.20	1.93	2.48
7	0.50	-0.14	1.44	2	2.87	2.98	3.04
8	-0.33	-0.45	.	3	0.54	1.99	2.51
9	0.34	.	.	4	-0.84	1.50	2.26
10	-0.77	.	.	5	1.35	1.41	1.14
11	0.34	-0.69	0.10	6	-0.92	1.86	2.28
Mast 1, 1976-08-20				7	.	1.43	1.97
1	1.28	1.99	1.74	8	.	-0.29	0.40
2	1.51	1.33	0.06	9	-0.37	1.91	2.34
3	1.42	1.59	-0.64	10	0.12	1.93	2.16
4	0.10	-0.37	-0.64	11	0.20	1.73	2.38
5	0.23	-0.62	.	Mast 2, 1976-08-20			
6	-4.23	.	.	1	1.80	1.49	1.74
7	0.27	1.15	.	2	0.80	1.49	1.74
8	0.08	0.73	.	3	.	.	1.59
9	-0.32	0.52	0.26	4	.	.	-0.35
10	0.13	-0.76	.	5	0.08	-0.20	2.04
11	.	1.34	1.44	6	0.92	0.86	1.94
Mast 1, 1976-08-26				7	-0.27	.	1.84
1	.	0.46	1.74	8	.	.	.
2	1.12	1.56	1.29	9	0.13	-0.76	.
4	1.18	1.62	.	10	-0.13	.	0.55
5	1.13	1.48	0.69	11	0.09	0.06	1.54
6	-0.81	-0.17	.	Mast 2, 1976-08-26			
7	.	.	.	1	1.85	1.85	1.59
8	0.14	0.28	.	2	1.44	1.67	2.04
				3	.	.	.

Run Zero-plane displacement
No. estimated from

	5	4	3
heights of measurement (m)		(m)	(m)

Mast 2, 1976-08-26

4	1.17	.	.
5	-0.26	0.46	1.74
6	.	.	.
7	.	.	-1.87
8	0.12	.	1.44
9	-0.95	0.08	-0.20
10	-0.45	.	0.07
11	.	.	1.34
12	0.33	-0.33	1.34

APPENDIX 4

Modified method of Least squares

In this method, the zero-plane displacement is not solved from the experimental data but d is chosen a priori. So only u_* and z_0 remain unknown. The method of least squares (App. 1) leads then to

$$\frac{\partial E}{\partial u_*} = -2 \sum_{i=1}^n (\bar{u}_i - (u_*/k) \ln(z_i - d) + (u_*/k) \ln z_0) \cdot (\ln(z_i - d) + \ln z_0) = 0 \quad (A4.1)$$

$$\frac{\partial E}{\partial z_0} = 2 \sum_{i=1}^n (\bar{u}_i - (u_*/k) \ln(z_i - d) + (u_*/k) \ln z_0) \cdot (u_*/k) \cdot (1/z_0) = 0 \quad (A4.2)$$

With the substitutions mentioned in Appendix 1, these equations turn to

$$\sum_{i=1}^n (\bar{u}_i - v_* x_i + v_* w) \cdot (x_i - w) = 0 \quad (A4.3)$$

and

$$\sum_{i=1}^n (\bar{u}_i - v_* x_i + v_* w) = 0 \quad (A4.4)$$

From Equation A4.4 follows

$$w = \bar{x} - (\bar{u}/v_*) \quad (A4.5)$$

Equation A4.5 equals Equation A1.9.

Substitution of Equation A4.5 in Equation A4.3 leads to

$$\overline{v y} - v_* \overline{y^2} = 0$$

or

$$v_* = \overline{vy/y^2} \quad (A4.6)$$

Then z_0 can be estimated from Equation A4.5.

Comparison of the method of least squares (App. 1) and the modified method of least squares (App. 2)

A comparison of the estimates of v_* according to Equation A1.14 and Equation A4.6 shows that Equation A4.6 can be obtained from Equation A1.14 by replacing \overline{vr} by \overline{vy} and \overline{yr} by $\overline{y^2}$, respectively. To estimate z_0 , the same equation can be used for both methods. The estimate of v_* , used in the equation for z_0 , however, is different for the two methods. Only if $g(d) = 0$ are the estimates of v_* from the two methods equal, since

$$g(d) = (\overline{1/y^2}) - \overline{vr}/(\overline{vy} \overline{yr}) = 0$$

then

$$\overline{vy/y^2} = \overline{vr/yr}$$

The difference between v_* estimated from Equation A1.14 and v_* estimated from Equation A4.6 if $g(d) = 0$ can be estimated. From Equation A1.14

$$v_{*,1} = \overline{vr/yr}$$

and from Equation A4.6,

$$v_{*,2} = \overline{vy/y^2}$$

If these equations are substituted into Equation A1.13,

$$g(d) = (v_{*,2}/\sqrt{\overline{vy}}) - v_{*,1}/\sqrt{\overline{vy}}$$

or

$$\overline{vy} g(d) = v_{*,2} - v_{*,1}$$

So the difference between the estimates of v_* is $\overline{vy} g(d)$.

This difference becomes considerable when

$$k g(d) \overline{vy} = k(v_{*,2} - v_{*,1}) \geq 5 \text{ mm/s}$$

For $k = 0.4$, $g(\bar{d}) \bar{v}_y \approx 12$ mm/s.

With $\bar{v}_y \approx 10$ mm/s - a usual value in the present experiment -,

$$g(\bar{d}) \geq 1.2$$

If the chosen \bar{d} differs widely from the optimum \bar{d} , $g(\bar{d})$ will be about 1.2. Then the difference between $u_{*,2}$ and $u_{*,1}$ will still be small.

In general, the difference between the estimates of v_* and u_* derived from Equation A1.14 and Equation A4.6 will be negligible and so Equation A1.14 may be used for the estimate of u_* in the modified method of least squares.