

## **FLOW-AID – a Deficit Irrigation Management System using Soil Sensor Activated Control: Case Studies**

J. Balendonck<sup>1\*</sup>, A. Pardossi<sup>2</sup>, H. Tuzel<sup>3</sup>, Y. Tuzel<sup>4</sup>, M. Rusan<sup>5</sup>, F. Karam<sup>6</sup>

<sup>1</sup> Greenhouse Horticulture, Wageningen University and Research Centre, Wageningen, the Netherlands

<sup>2</sup> Dept. of Biology of Crop Plants, University of Pisa, Pisa, Italy

<sup>3</sup> Dept. of Agriculture Structure and Irrigation, Ege University Faculty of Agric., Bornova-Izmir, Turkey

<sup>4</sup> Dept. of Horticulture, Ege University Faculty of Agriculture, Bornova-Izmir, Turkey

<sup>5</sup> Faculty of Agriculture, Jordan University of Science and Technology, Irbid, Jordan

<sup>6</sup> Dept. of Irrigation and Agro-Meteorology, Lebanese Agric. Research Institute, Tal Amara - Zahle, Lebanon

### **ABSTRACT**

This paper presents a deficit irrigation management system that can be used at the farm level, when there is a limited water supply, poor water quality or when leaching is prohibited. It consists of a network of in-field irrigation controllers and soil sensors, connected via a wireless link to a farmer's computer. Further, a decision support system (DSS) that helps farmers to choose an appropriate irrigation scheduling strategy in view of the amount and quality of available irrigation water, plant status, weather and local constraints. Scheduling strategies and sensor thresholds can be programmed into the irrigation controllers. During three growing seasons from 2007 to 2009, different versions of the system were evaluated for high value vegetable and ornamental crops in Italy, Turkey, Lebanon, Jordan and the Netherlands. The sites differed in local goals and constraints, the irrigation infra-structure and the availability and quality of irrigation water. We observed that, compared to common grower practices, sensor-activated deficit irrigation scheduling largely enhances water use efficiency and saves from 16% up to 69% of water, as well as reduces leaching. Good marketable crop qualities were obtained using moderate deficit regimes. We achieved acceptable marketable yields at higher depletion values or when using poor-quality water. Deficit depths must be chosen carefully, and an optimized fertigation strategy is a pre-requisite to maintain sustainability of the growing media or soils. The system worked well, but to ensure fail-safe operation, it must be extended with a fault detection and warning system. The system was implemented by using commercially available technologies and integrating them into an irrigation management system by adding new hardware and software components. Although parts of the system are commercially available and are used in practice, the FLOW-AID system as a whole is not yet available on the market, but irrigation equipment suppliers are encouraged to implement the presented principles.

---

\* Corresponding author: jos.balendonck@wur.nl

## INTRODUCTION

Fresh water (FW) sources are becoming scarce, and since agriculture is the largest water user, it is the main competitor for domestic and industrial water users. Therefore, farmers try to avoid spilling of water and ensure that all available irrigation water is being used by the crop. To compare cropping system efficiencies, Water Use Efficiency (WUE) defined as the dry matter production per water loss (g/kg) is being used as an index. To raise WUE, and to achieve “more crop per drop”, growers may implement fairly simple changes to their irrigation equipment and cropping system. For instance, to avoid leakage and evaporation, closed pipes instead of open channels; to enhance water application efficiency, drip instead of furrow or sprinkler irrigation; to avoid evaporation losses, a soil-coverage could be used. To improve WUE further after optimizing the irrigation and cropping system, growers can match water supply with actual crop water demand. A common approach for this is to estimate daily crop water demand by using an evapo-transpiration model like the Penman–Monteith equation (PMe) (Allen et al., 1999) or derivatives such as the CIMIS (California Irrigation Management Information System) equation proposed by Pruitt and Doorenbos (1977). Besides climatic data, these models require input for crop and phenological stage dependent parameters like the crop coefficient ( $K_c$ ), as can be obtained from a FAO database (Allen et al., 1999). Though less used, another method which is based upon an estimate of the crop available water in the root zone, is soil moisture sensor (SMS)-activated irrigation scheduling (IS) (Meron, 2001 and Pardossi et al., 2009b).

In case the actual crop water demand is larger than the amount of water available from FW resources, grower must use higher values for the Management Allowable Depletion (MAD) factor, and apply lesser water or additionally use non-FW resources like saline, treated or reclaimed wastewater (RW). Limiting water supply or using marginal water resources may easily lead to a lower crop yield and quality. However, Geerts and Raes (2009) state that DI is successful in increasing water productivity for various crops without causing severe yield reductions, under the condition that growers are careful with their water and fertilizer management. Tools informing them about crop health, soil water availability, water quality and the climatic conditions, may help to make sound decisions about water and fertilizer doses, water source and irrigation timing. We present a farm-level DI system based upon a distributed control concept for SMS-activated IS and the allocation of multiple quality water sources called: FLOW-

AID<sup>†</sup>. With various system implementations and for different crops, as compared with common grower practices, we demonstrate the potential to save fresh water and reduce leaching while maintaining acceptable product yields.

## METHODS AND MATERIALS

The FLOW-AID system (Fig. 1) consists of irrigation controllers (IC), placed in each individual controllable area (a plot) for all irrigated crops at the farm (zones). IC's, working continuously and autonomously, regularly read-out SMS's and initiate irrigation events through opening and closing a valve based upon a set of irrigation rules and set-points. They safe-guard the operation of the system by employing a set of safety rules. More sophisticated IC's might have added complexity like data logging and advanced calculating options, to be able to perform e.g. ET-model based irrigation. They can drive multiple water sources of distinct water qualities through a set of valves. The IC's are connected via a wireless link to a local (farm) computer (Balendonck et al., 2008).

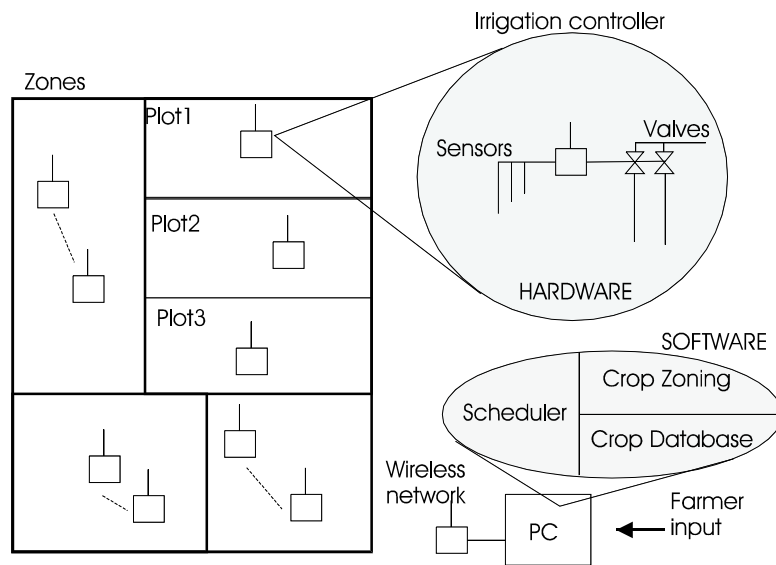

**Figure 1** – Schematic representation of the FLOW-AID system.

A Decision Support System (DSS) helps growers to optimise their irrigation and fertilizer management in view of their selected crop, cropping system, the expected water availability, climatic conditions as well as crop development on a day-to-day basis (Anastasiou et al., 2009). For this, the DSS incorporates a database of crops and “best practice irrigation strategies” as well as a crop stress model for DI. It further contains an advisory module

<sup>†</sup> FLOW-AID is the acronym for: Farm-Level Optimal Water management, an Assistant for Irrigation under Deficit.

(Incrocci and Pardossi, 2009) that computes an optimal fertigation recipe based upon cropping stage, deficit depth and water quality. It also incorporates a farm zoning and economic crop planning tool which advises growers upon selecting crops giving the largest gross margin under given constraints (Dominguez et al., 2008). The DSS may run either on the same local computer or on a remote host computer located at a service provider (e.g. an advisory service, river basin water management, growers association or a computer/software supplier). On a day-to-day basis, but not necessarily strict regularly, growers may check IC performance, crop status and water availability. In addition, they can consult the DSS and, if needed, they may decide upon changing the IS strategy.



**Figure 2** – A WET-sensor (Delta-T-Devices, UK) installed in the rooting zone at 15 cm and a 5TE (Decagon, US) installed underneath the rooting zone at 30 cm depth, both to measure water content, EC and temperature (left); a wireless sensor network (eKo, Crossbow, US) and irrigation controller (GPI, Delta-T Devices, UK) installed just after planting Iceberg lettuce in a Dutch case study.

During three growing seasons (2007 – 2009), the system was evaluated in Italy, Turkey, Lebanon, Jordan and the Netherlands. Sites differed in constraints like climatic condition, irrigation structure, crop, water supplies, availability and quality of irrigation water and local goals. Each trial was performed as a randomized-block experiment with at least 4 replicates per treatment. The controller network was implemented using standard irrigation equipment, like WET-sensors and programmable IC's (GPI), both from Delta-T Devices (UK) as shown in Figure 2. Equipment was added as required by the specific case study needs. The evaluated systems were all different, covering a wider scale of complexities, especially the way fertigation was handled. In Italy and Turkey a modern fertigation computer (Spagnol Automation, Italy) was used, in other cases fertigation was done according to

local practices. After assembly and installation, a wired or wireless connection (Crossbow-Eko, US) was established with a PC, and the DSS (Geomations S.A., Greece) was set-up to control the IC network (Figure 3).

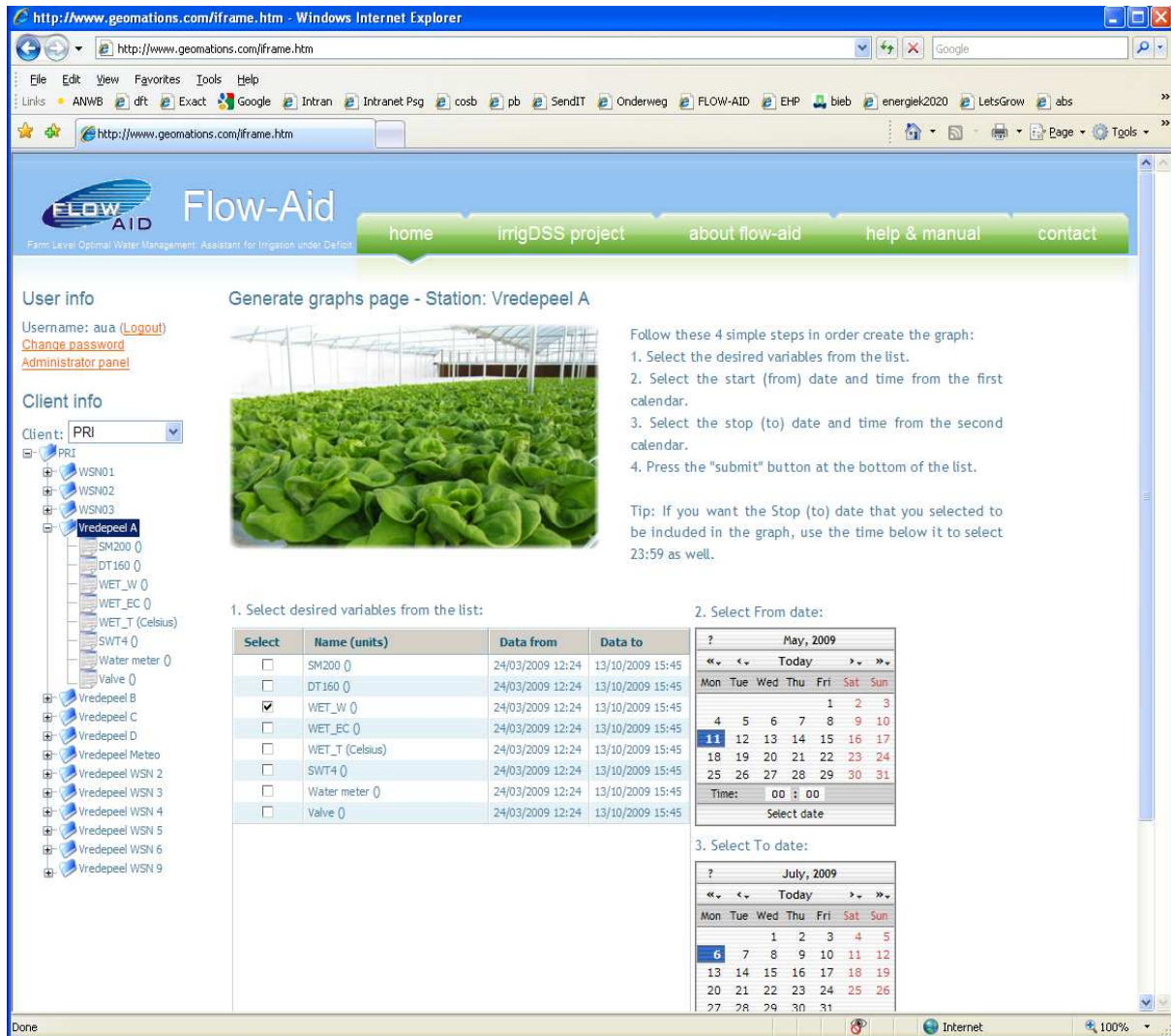

**Figure 3** – A web-based DSS tool, containing, a platform for data exchange and presentation (Geomations S.A., Greece).

Case Study: Container-grown landscaping ornamentals in a Mediterranean climate (Italy)

In Tuscany (Italy), the major European region for container-grown ornamentals in outdoor nurseries, growers use drip or sprinkler irrigation, but WUE is low because of over-irrigation (Pardossi et al., 2009b). The quality of available water is getting worse every year, especially along the coast with rising EC levels. In future, probably high saline waste water may be the main source for crop irrigation. A prototype fertigation controller (Incrocci et al., 2010) was developed making use of a WET-sensor to obtain volumetric water content and electrical conductivity

(EC) of the substrate. A dual water source was used with low-salinity groundwater (GW) and saline reclaimed wastewater (RW) and the IS strategy was based upon using as much RW as possible, and using GW only when the EC passed a pre-defined threshold. The water source and fertigation regime were chosen based upon a crop stress index derived from the pore water EC in the substrate. WET-sensors were calibrated for pore water EC for the peat-pumice growing media used in this area as an alternative for the Hilhorst-equation which is defined as:

$$EC_p = \frac{\varepsilon_{\text{water}}}{\varepsilon - \varepsilon_{\sigma=0}} EC , \quad (1)$$

where  $\varepsilon$  is the measured permittivity,  $\varepsilon_{\text{water}}$  the permittivity for pure water corrected for temperature and  $\varepsilon_{\sigma=0}$ , a constant depending on the substrate material (Hilhorst, 2000). The prototype was evaluated at the experimental research station Centro Sperimentale Vivaismo (CeSpeVi) in Pistoia, and the cultivation of different species in the same plot (*Photinia x fraseri*, *Viburnum tinus*, *Prunus laurocerasus* and *Forsythia intermedia*) was simulated following an accustomed practice in the Pistoia nurseries (Incrocci et al., 2010, these proceedings). This approach was compared with three IS strategies using only GW: Timer control (standard farmers practice), an ET-model and SMS-activated IS with hydraulic tensiometer (SWT4, Delta-T Devices, UK) or WET-sensor (Pardossi et al., 2009a).

Case Study: Drip-irrigated cucumber grown in greenhouses under a mild-winter climate (Turkey)

The Tahtalı Dam supplies fresh drinking water to Izmir, the third largest city in Turkey. Due to pollution risks, authorities have issued a regulation discouraging leaching into the catchment area of the dam, affecting largely local greenhouse vegetable production, being the major local agricultural activity. To introduce SMS-activated IS and to define practical recommendations to prevent leaching while keeping acceptable crop yields, five on-farm trials were conducted in a poly-ethylene greenhouse in Yeniköy-Menderes/İzmir (Tuzel et al., 2009) with cucumber (*Cucumis sativa* L.). The cultivar was ‘AT 191’ in first trial, being suitable for a long crop cycle, and in the remaining four trials it was ‘Champion’ because of the short cycle. Fertilizers were applied automatically (Figure 4) via a pressure compensated drip irrigation system. Besides water use, crop growth, water stress and drain (lysimeter), soil and irrigation conditions were monitored at 15 - 20 and 40 cm depths with WET-sensor, SM200, water-filled-tensiometers, theta-probes (Delta-T-Devices, UK) and dielectric tensiometers (Whalley, 2009). Three DI strategies (MAD = 20, 40 and 60%) were compared with current farmers practice. IS was based upon a WET-sensor placed (15-20 cm) in the first two trials. In other trials, irrigation started based upon a dielectric tensiometer and stopped at a certain water dose. In the fourth trial this dose was modulated on-the-fly by the DSS.





**Figure 4** – A fertigation unit installed at the Turkish site (Spagnol Automation, Italy).

Case Study: Drip-irrigated eggplant in semi-arid climate (Lebanon)

The Bekaa Valley is a semi-arid area accounting for about half of the agricultural production in Lebanon. A quarter of the area is used for irrigated agriculture using surface, furrow, basin and flooding techniques (64%), sprinkler irrigation (28%) and drip-irrigation (8%). About 52% of the water comes from deep-well GW sources. Irrigation costs have gone up drastically (energy) and water quality has shown a gradual deterioration. Farmers with an improper farm-level water management need to adopt new water saving techniques.

In summer 2009 (May-September), at the Tal-Amara Research Station, a field trial with drip-irrigated eggplant (*Solanum melongena* L.) cultivar 'Baladi', was conducted on a fairly-drained, clay soil with an average bulk density of  $1.41 \text{ g cm}^{-3}$  in the 90 cm top layer (Chazbeck, 2008; Saliba, 2009). The field capacity (FC) at  $-0.33$  bar and permanent wilting point at  $-15$  bar averaged 29.5% and 16.0% respectively by weight, resulting in a plant available water holding capacity of 170 mm. SMS-activated irrigation was used with GP1 controllers and SM200 sensors (Delta-T-Devices, UK) with a MAD of 30%. As a reference strategy, a well-watered treatment at 100% was used. Three deficit treatments were evaluated at respectively 75%, 50% and 25% of the gross irrigation volume.

Case Study: Drip-irrigated tomato in arid climate (Jordan)

Jordan has very limited fresh surface and ground water resources. The demand on water is ever increasing and the average yearly rainfall, of which 94% evaporates, leaves very little addition to available water. The government

promotes efficient water use and the use of reclaimed waste water. Consequently, farmers need to adopt their usual irrigation practices to the use of treated waste water with high salt and nutrient content. At the Research Centre of Jordan University of Science and Technology in Irbid, two field trials (see Figure 5) with drip-irrigated tomato (*Solanum Lycopersicum* L.) cultivar 'Super Red' were conducted (Rousan et al., 2008). Automatic SMS-activated IS for different water quality and deficit levels using SM200 and WET-sensor (Delta-T devices, UK) were compared with farmer practice using tensiometers and Watermarks (Irrometer, Co. Riverside California). Soil was prepared according to common growers practice and covered with a black foil after planting to prevent evaporation losses. The standard FAO advice (MAD = 40%; Allen et al., 1999) was used as a reference (Full 1 and 2) and compared with a DI strategy (MAD = 60%), while using two water qualities (Deficit 1 and 2): fresh ( $EC_{\text{average}} = 0.8 \text{ dS}\cdot\text{m}^{-1}$ ) and RW ( $EC_{\text{average}} = 2.0 \text{ dS}\cdot\text{m}^{-1}$ ).



**Figure 5** – *Jordan Case Study. Tomato grown with fresh water under Full Irrigation (left-side) and Deficit Irrigation (right-side).*

*Case Study: Drip-irrigated lettuce under rain-fed conditions (The Netherlands)*

Water and fertilizers drain very rapidly into the sandy soils found in Limburg, in the south of the Netherlands. Crops suffer rapidly from drought and nutrients leach into the ground water during heavy rain-fall. To reduce nitrate emission, while keeping a high crop quality and yield, growers must apply water and fertilizers more precisely. In summer 2009 (48 days), an experiment was conducted at the PPO Research Station at Vredepeel evaluating the use of SMS-activated IS, controlled fertigation and drip irrigation. Iceberg lettuce (*Lactuca sativa* L.) was grown on loamy-sandy soil beds covered with black plastic foil preventing infiltration of rain. The aim was to prevent leaching



by maintaining a constant water level in the root zone at two depths. Irrigation was triggered with a WET-sensor at 15 cm, and the threshold level and initial dose (3 mm) were set using a MAD = 35%. After well rooting (21 days), the dose was computed by the DSS using a WET-sensor just underneath the root-zone at 30 cm. With an upward trend in water content the dose was lowered, and with a downward trend the dose was raised. Standard farmer practice (no foil; granular fertilization at 100 kg N/ha) was compared with three fertilizing strategies: (1) granular fertilization (100%) and two fertigation (83%, 58%) strategies (2 and 3) for which the dose matched crop growth.

## RESULTS

Table 1 gives a summary of the most important data related to water use. Instead of using the standard definition for WUE, we used the Fresh, Marketable WUE (Geerts and Raes, 2009) defined as the total fresh crop weight produced per volume of the total applied water including rain water ( $\text{kg}/\text{m}^3$ ). We computed a water saving index (%) for each case by comparing the WUE for each treatment to the WUE obtained by a common farmers practice.

**Table 1** – Case study results with obtained Water Use Efficiencies (WUE) and Water Saving Indices.

<i>Case Study</i>	<i>Strategy</i>	<i>Marketable Crop Yield</i>	<i>Water Use</i>	<i>Drainage</i>	<i>Ratio Fresh to Total Water</i>	<i>Fresh Marketable WUE</i>	<i>Water Saving Index<sup>8</sup></i>
	<i>(MAD%, dose)</i>	<i>(kg/m<sup>2</sup>)</i>	<i>(mm)</i>	<i>(mm)</i>	<i>(%)</i>	<i>(kg/m<sup>3</sup>)</i>	<i>(%)</i>
Ornamentals <sup>8</sup>	Farmer (Timer)	-	540 (n=3)	237	100	-	0 <sup>1</sup>
	ET-Model	-	410 (n=1)	94	100	-	24
	SMS (WET+TM) <sup>2</sup>	-	379 (n=3)	84	100	-	<b>30</b>
	WET (GW+RW) <sup>2</sup>	-	413 (n=2)	119	66	-	24
Cucumber	Farmer	25.4	717 (n=5)	92.4	100	35.4	0 <sup>1</sup>
	Deficit 1 (20/100%)	29.0	683 (n=5)	10.3	100	42.4	17
	Deficit 2 (40/100%)	23.8	545 (n=5)	0	100	43.7	<b>19</b>
	Deficit 3 (60/100%)	21.2	495 (n=5)	0	100	42.7	17
Tomato	Full 1	1.8	425 (n=2)	-	100	6.1	0 <sup>1</sup>
	Full 2	2.3	410 (n=2)	-	0 <sup>3</sup>	7.0	13
	Deficit 1	1.6	275 (n=2)	-	100	7.0	13
	Deficit 2	1.6	275 (n=2)	-	0 <sup>3</sup>	8.1	<b>25</b>
Egg plant	Full (30/100%)	3.4	94.6 (n=1) <sup>6</sup>	-	100	35.7	0 <sup>1</sup>
	Deficit 1 (30/75%)	3.9	71.0 (n=1) <sup>6</sup>	-	100	54.4	<b>35</b>
	Deficit 2 (30/50%)	2.0	47.3 (n=1) <sup>6</sup>	-	100	41.3	14
	Deficit 3 (30/25%)	1.3	23.7 (n=1) <sup>6</sup>	-	100	23.7	-51
Lettuce	Farmer	4.1	186 (n=1)	-	50.5 <sup>4</sup>	22.2	0 <sup>1</sup>
	Deficit 1 (35/- <sup>7</sup> )	4.2	67.6 (n=1)	-	59.2 <sup>5</sup>	62.5	64
	Deficit 2 (35/- <sup>7</sup> )	4.7	69.6 (n=1)	-	60.3 <sup>5</sup>	68.0	67
	Deficit 3 (35/- <sup>7</sup> )	4.8	65.6 (n=1)	-	57.9 <sup>5</sup>	72.6	<b>69</b>

<sup>1</sup>Values not obtained or available; <sup>2</sup>Reference treatments; <sup>3</sup>WET = WET-sensor, TM = Tensiometer, GW = Ground Water, RW = Reclaimed Wastewater; <sup>4</sup>RW; <sup>5</sup>Including 92 mm rain water; <sup>6</sup>Including an estimate of 30% of 92 mm rain water leaked through the foil coverage; <sup>7</sup>Water use calculated based upon an ET-model; <sup>8</sup>Dose variable and computed with DSS; <sup>8</sup>Refers to a multi-crop irrigation scheme with four different ornamental species; <sup>8</sup>Maximum Water Saving Index printed in bold type characters.

### Ornamentals

In this trial, WET-sensors were used to obtain Pore Water EC by using the model from Hilhorst (2000). It showed that the Hilhorst model was not appropriate for the peat-pumice mixtures used, and a new model (Incrocci et al., 2009) was obtained yielding the following equation (see Figure 6):

$$EC_p = (2088.5 \cdot \varepsilon^{-1.836}) \cdot EC \quad (2)$$

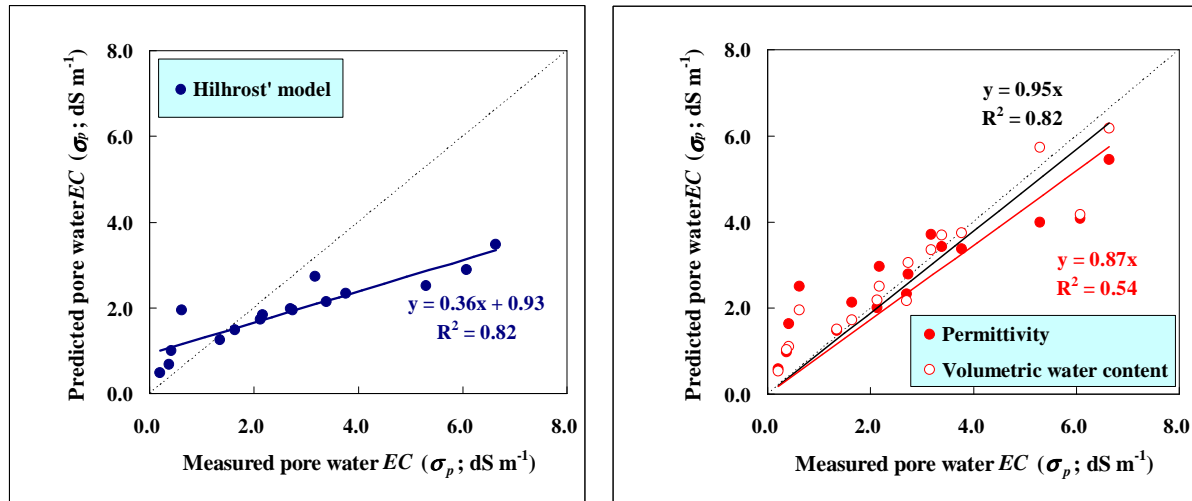

**Figure 6** – Results of a WET-sensor calibration for pore water EC in a peat-pumice mixture for container-grown ornamentals using Hilhorst model (left) compared to a new specific calibration (right).

As crop yields were not recorded, WUE could not be obtained and to compute the Water Saving Index we used the Water Use directly. Compared to farmer practice (a timer control), all DI strategies did not significantly influence plant growth. They all reduced significantly the seasonal water consumption (24 – 30%) as well as the drainage fraction because of a lower irrigation frequency (85 – 119 mm compared to 237 mm). For both the ET-model as well as SMS-activated IS, the water saving performance was similar. The dual water source approach had a slightly higher drain fraction.

### Cucumber

With the Deficit 1 treatment a higher marketable crop yield (14%) than with farmer’s practice was obtained. The Deficit 1 regime reduced the leaching considerably (10.3 mm) compared to farmers practice (92.4 mm). Deficit 2 and 3 gave slightly smaller yields, but with nearly no noticeable percolation losses. All deficit treatments lead to

similar water saving results (17 – 19%). The new dielectric tensiometer (Whalley et al., 2009, Figure 7) performed better than hydraulic tensiometers due to the larger dynamic range, especially in the drier deficit regimes (Figure 8).



**Figure 7** – A prototype dielectric tensiometer (DT160, Delta-T-Devices, UK) used in Turkey case study on cucumber, shown while wetted prior during installation.

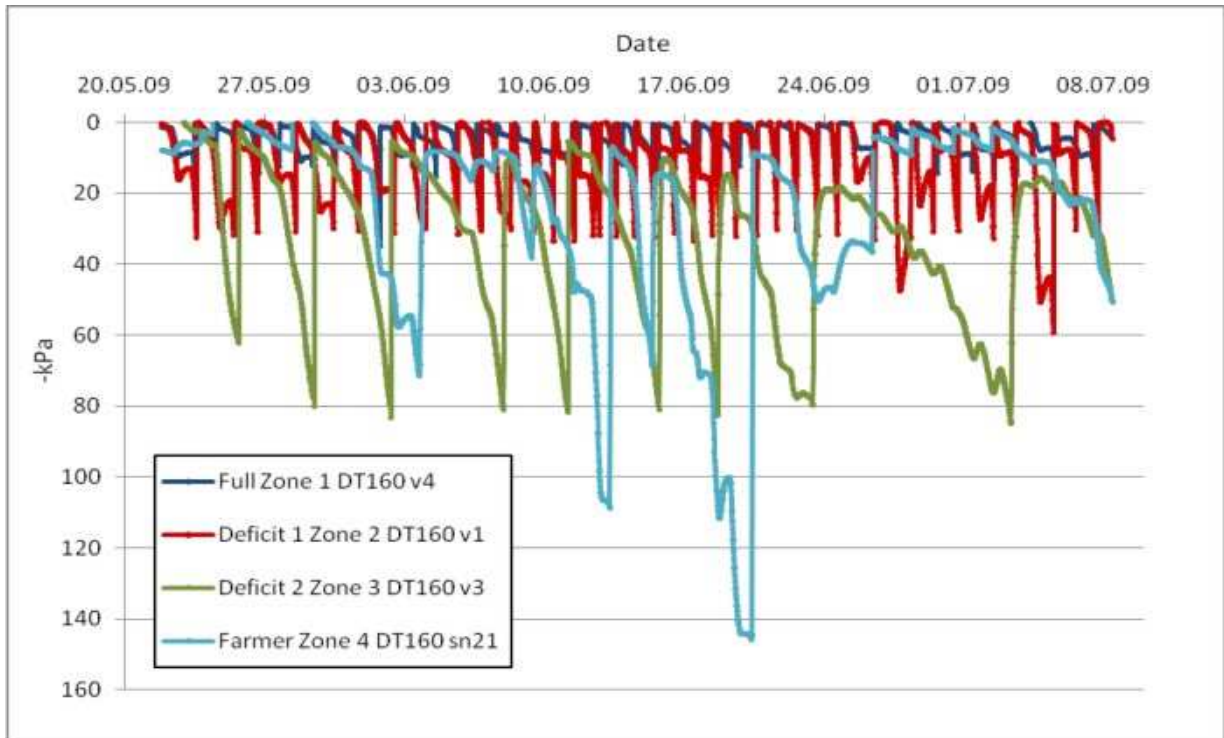

**Figure 8** – Readings from the DT160 for several deficit treatments.

### Tomato

The marketable yield was highest with FI (1.8 – 2.3 kg/m<sup>2</sup>), both for FW and RW. The Water Use was significantly smaller for the deficit treatments (275mm compared to 410 – 425mm). Deficit 1 with FW gave a small water saving of 13%. Water Use Efficiencies were slightly higher (12 – 13%), and higher nitrogen, phosphorus and potassium contents in the plant tissue were found, when RW was used. Compared to FI, smaller size and more injured fruits (non-marketable) were found with DI. Use of RW resulted in accumulation of salt in the top soil, which was observed more under DI (Figure 9). A continuous control was not possible because water availability was limited to two times per week.

### Egg-Plant

The Deficit 1 regime (75%) had the highest yield (3.9 kg/m<sup>2</sup>) and water saving index (35%). The yield is slightly more than with FI (3.4 kg/m<sup>2</sup>), but considerably more than common farmer's production levels with a traditional furrow irrigation system (1.5 – 2.0 kg/m<sup>2</sup>). The Deficit 1 regime led to less fruits (about 33%) but with a 50% higher mean fruit weight. DI with 50% and 25% dose, gave considerably lower yields, even resulting in a negative water saving index for a dose of 25%.

### Lettuce

For all treatments the crop quality was high and similar, and most of the produce (97.2 – 98.8%) was ranked as Class 1. Marketable crop yield was about 15% higher for the fertigated deficit regimes. During heavy rainfall events, infiltration through the foil occurred in the DI plots, and an estimated amount of 30% of the rainfall was added to the Water Use. The SMS-activated treatments used considerable less water (65.6 – 67.6 mm) compared to farmer practice (186 mm). For the farmer treatment, after harvest, nearly no Nitrogen was found in the top soil-layer (0 – 30 cm), while in the DI treatments still some Nitrogen was found, the most in Deficit 1 for which bulk fertilizers were used. For Deficit 1 crop yield was slightly smaller than for Deficit 2 and 3, in spite of the Nitrogen left in the soil. This was probably due to the dryer regime and granular fertilizer that did not mineralize. Compared to farmers practice, the SMS-activated DI treatments started irrigation more frequently and used a smaller dose, which lead to a significant large water saving (64 – 69%) and a lesser dynamical trend in soil water contents. The results of the automatic dose calculation by the DSS to prevent leaching are shown in Fig. 10. Based upon these observations, and although actual drainage was not measured, we concluded that in farmers practice a fairly large portion of Nitrogen leached to deeper layers, as well causing a smaller yield.

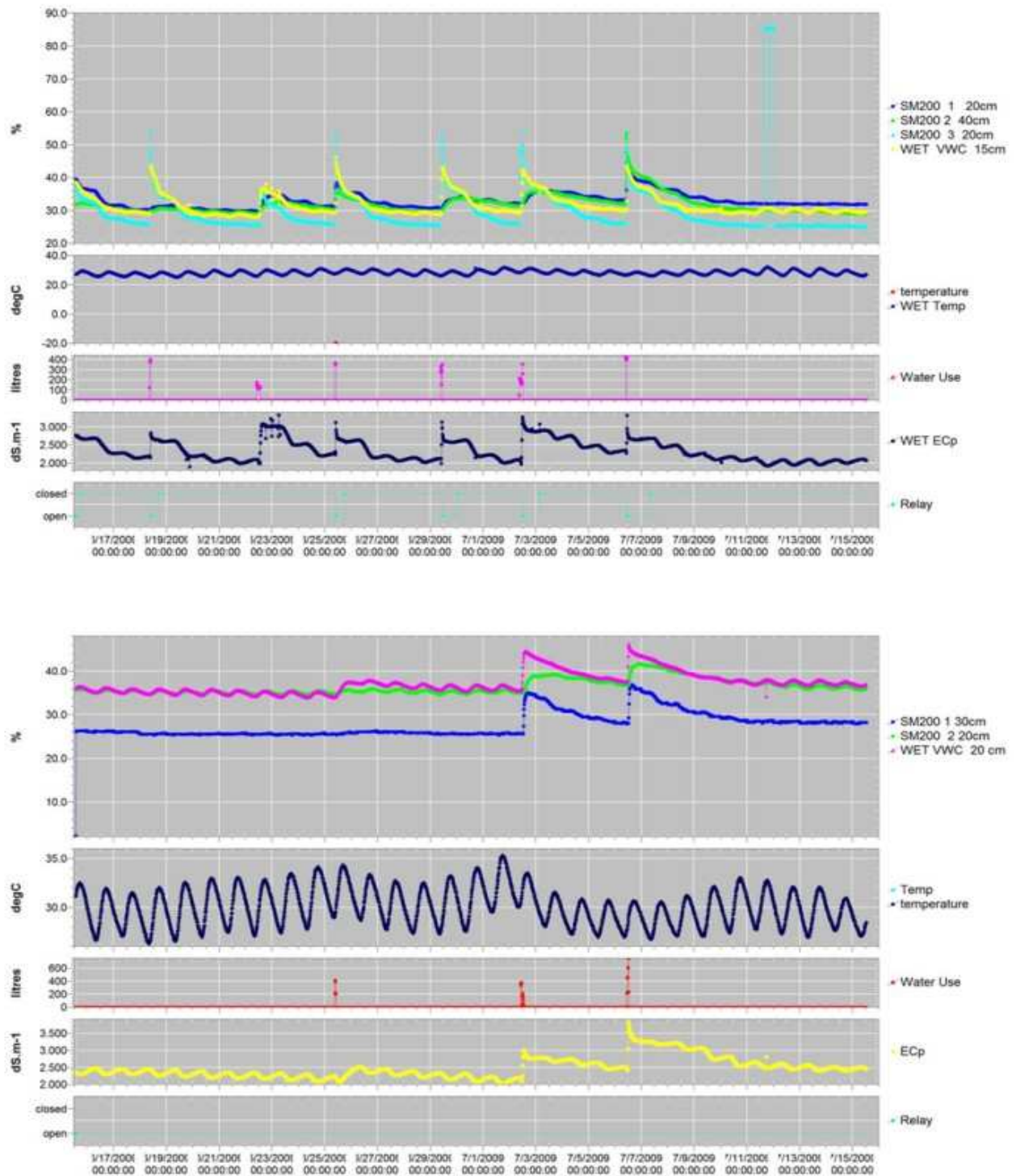

**Figure 9** – Results from the Jordan case study. Sensor readings of SM200 and WET-sensor for treatment with treated wastewater, for Full Irrigation (top) and Deficit Irrigation (bottom). Pore Water EC ( $EC_p$ ) values obtained from WET-sensor by using the Hilhorst equation (Hilhorst, 2000).



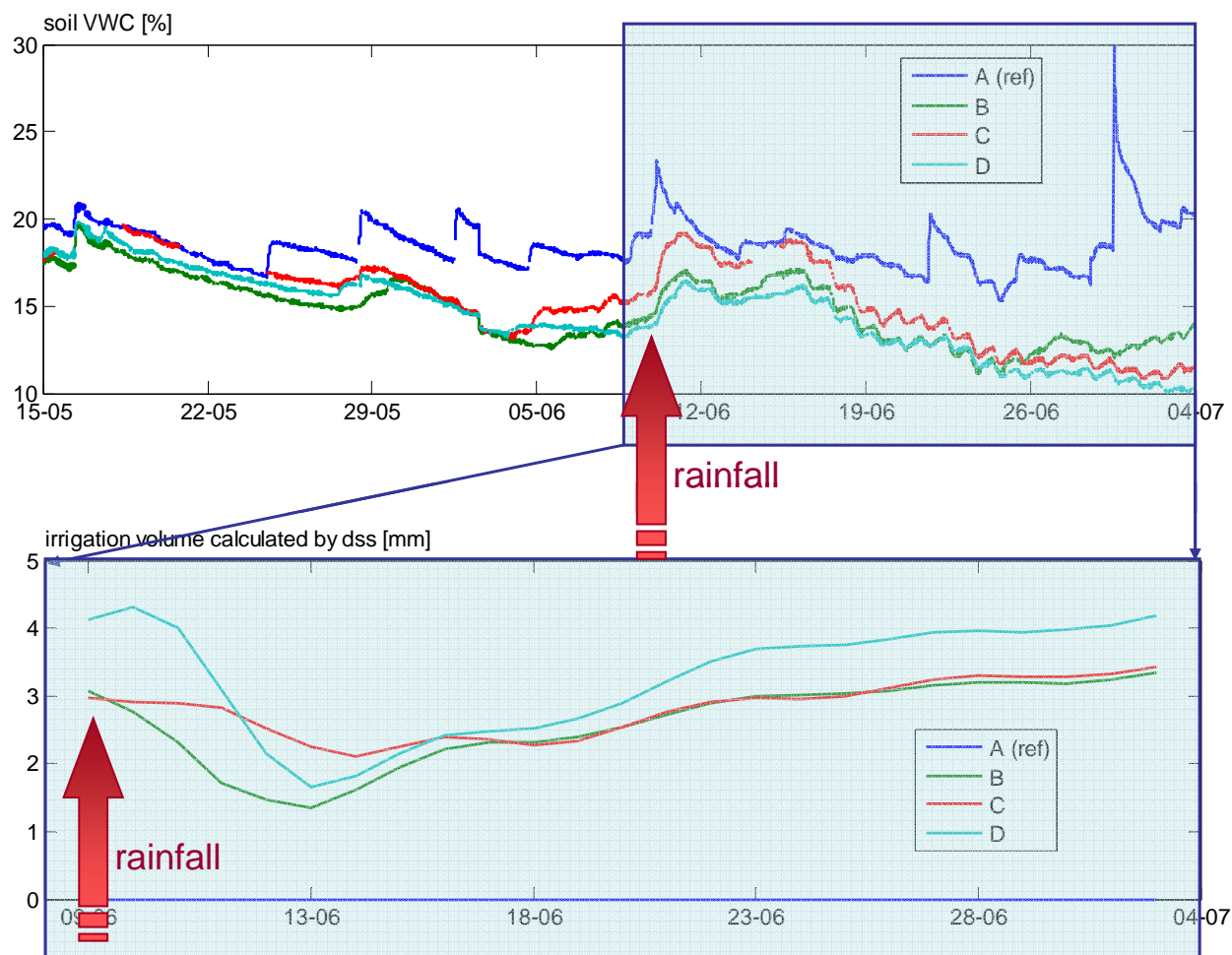

**Figure 10** – Dutch case study example on DSS functionality; drip-irrigated and fertigated Iceberg lettuce under rain-fed conditions. Above: Volumetric Water Content for all 4 treatments, and the blue line refers to the farmer treatment. Below: Calculated irrigation dose. After rainfall the dose is decreased and then slowly increased again.

## DISCUSSION

### Saving water

Geerts and Raes (2009) state that DI is successful in increasing water productivity for various crops without causing severe yield reductions. Indeed, we see in our case studies that DI leads to higher water use efficiencies, with maximum values ranging from 19% to 69% for moderate DI regimes with MAD-values ranging from 30 – 40%. Over this range, product quality may vary largely, as e.g. fruits may vary in total and sizes. Marketable yields vary from -11% up to +17%, compared to farmers practices or FI. Maximum marketable yields are not necessarily

obtained using the DI strategy with the highest water saving ratio. It was seen that farmers sometimes tend to overirrigate their crop, resulting in leaching of fertilizers and consequently a yield reduction, which was observed by Geerts and Raes (2009) as well. Therefore, when using DI, farmers must choose the DI-depth based upon local situations like availability and costs of water as well as market prices.

#### Prevention of leaching

For cucumber and lettuce, compared to farmers practices, we were able to reduce leaching with a considerable amount by using moderate DI. By using optimized (drip-irrigated) fertigation, compared to bulk fertilization, slightly higher yields could be obtained taking advantage of non-leached fertilizers. In container ornamental crops, SMS-activated IS reduced considerably the leaching of nitrates and phosphates compared to the conventional grower's practice. With more severe DI zero leaching could be obtained, but this implies that the composition of the irrigation water must match exactly crop nutrient uptake. Zero leaching is not sustainable when a saline water source is used. In the ornamental trial we allowed for a small leaching fraction to prevent salinity build-up. To make such a system sustainable, the drain water could be collected and re-used after mixing and desalinization. We showed that while irrigating with a saline water source, and by monitoring substrate salinity using WET-sensors, we were able to maintain a pre-set EC-level in the growing media, making only minimal use of a FW source. In rain-fed agriculture, as was observed in the lettuce trial, rain and over-irrigation are the main cause of leaching. The foil only partly blocked the rain, but it reduced leaching considerably. However, farmers have indicated not to be keen on implementing the foil because of the short cropping time, material costs and labour intensive handling.

#### Use of reclaimed wastewater

A high water saving ratio (25%) was obtained in tomato trials with a DI strategy. Use of RW led to higher yields due to higher organic compounds and plant nutrients. However, it is not likely that farmers will use RW in combination with such a DI strategy, due to the lesser fruit quality and yield and the fact that IS is more critical. Nevertheless, even when using RW, a moderate DI regime can be used for which acceptable fruit quality and yield, as well a lower water use can be obtained. As such, SMS-activated DI is a good tool. However, a straightforward programmed SMS-threshold with a preset dose was not optimal due to a non-continuous water supply. We suggest to make use additionally of ET-forecasting to find an optimal dose or to use a local water buffer. Considerable FW savings were obtained in the ornamental trials, when using high saline RW in combination with a small leaching fraction. A FW

source was used only when the crop approached a salinity stress threshold level. This was made possible by using WET-sensors giving feedback about salinity, which was not possible using a timer or an ET-model.

#### Decision Support System

A minimal version of the DSS was implemented at a remote host computer (Anastasiou et al., 2009) and tested in the lettuce and cucumber trials with a limited set of DI-rules. On a daily basis, or upon reception of new data, the DSS computed new irrigation control parameters (thresholds, doses and timing) which were sent via e-mail to the farmer, who set the irrigation controllers manually. The DSS could have updated the irrigation schedulers directly and without growers intervention. However, it showed that to make such a system fail-safe and robust, the DSS should not only incorporate DI expertise, a crop database and stress model, but as well an observer of the performance of the irrigation controllers, detecting any faulty condition (leakage, power failures etc.) and major changes in crop development and growing media. The DSS should use, combine and analyse all available data, and alert the grower upon any critical event needing his intervention. Such warning system would be very beneficial for growers, even while using a manual control. The full capabilities and flexibility of the DSS and the crop stress database upon reprogramming the irrigation controllers on-the-fly and adapt the DI-strategy to changing constraints was not explored in the case studies. We anticipate that by doing so, the water saving performance, crop yield and crop quality could be enhanced even more.

#### Costs and farmers use of the DSS and SMS

With respect to the aim to save water or reduce leaching, the system performed well. The system could be adapted to several different farmer practices, and apart from a few minor failures, the technical implementations of sensors, controllers and wireless systems performed well. However, investments, operating and maintenance costs are relatively high. Therefore, successful implementation will depend solely on the outcome of an economic evaluation. Costs must be covered by extra income from savings on water, fertilizer and energy and benefits from a higher product yield and quality. All depends on local constraints and especially on the price for FW and water treatment besides the enforcement of legislation. In many cases water is still too cheap to change over to SMS-activated DI, but in cases where farmers use RW we feel that the break-even point has been reached already. SMS's are useful for IS but its application demands extra skills, especially due to soil variability. It is advisable to adapt the DSS so that it automatically checks sensor calibration and fine-tunes set-points. Farmers are interested to use sensors and a DSS, even for just monitoring soil water dynamics, but there is a demand for more accurate and cheaper sensors.

## **RECOMMENDATIONS**

Growers are advised to give more frequently water and nutrients with smaller doses, matching more closely the crop demand over time, preferably by using an automated system, which can save a lot of work. SMS-activated IS is a tool that can help farmers to manage DI in a controlled way under severe conditions of water availability and quality. Industry may take up the FLOW-AID concept and should focus on accurate, low-cost sensor and controller technology and a robust DSS capable to serve a broad diversity of cropping systems and constraints.

## **CONCLUSIONS**

SMS-activated DI scheduling may significantly enhance water use efficiency and reduce leaching. In our case studies and compared to common grower practices, it saved water from 19% up to 69% while maintaining acceptable yields (-6% to +17%) and crop quality. Large DI depths influence crop quality and yield severely, but it is possible to achieve acceptable crop quality and yields at moderate DI-depths. RW or saline water sources can be used, even under DI regimes. However, to prevent crop losses and salinity built-up it is advised to use eventually lower EC water to maintain the soil EC at an acceptable level and to initiate a leaching event when needed. Continuous EC-monitoring with WET-sensors is an useful tool for this. An optimized fertigation strategy, matching crop demands is a pre-requisite to maintain sustainability of the soil or growing media, especially when RW or saline water is being used. The DSS works well, and to ensure a fail-safe operation in growers practice, an automatic fault detection and warning system must be implemented.

## **ACKNOWLEDGEMENTS**

The FLOW-AID system ([www.flow-aid.eu](http://www.flow-aid.eu)) was developed through a close partnership between research institutes, universities and SME's; mainly funded by the European Union under the contract 036958 in the 6<sup>th</sup> Framework Programme. We thank all (un-mentioned) national funds that contributed to this work and the companies GEOMATIONS s.a. (Greece), Spagnol Automation (Italy) and Delta-T Devices Ltd (UK) for their contributions to the experiments and the supply and adaptations of the software, sensors and fertigation equipment.

## GLOSSARY OF TERMS

CIMIS	California Irrigation Management Information System equation	IS	Irrigation Scheduling
DI	Deficit Irrigation	K <sub>c</sub>	crop coefficient
DSS	Decision Support System	MAD	Management Allowable Depletion factor
EC, EC <sub>p</sub>	Electrical Conductivity, Pore Water EC	PC	Personal Computer
ET	Evapo-Transpiration	PMe	Penman–Monteith equation
ε	Dielectric permittivity	RW	Reclaimed Wastewater, also used for treated waste water
FC	Field Capacity	SMS	soil moisture sensor
FW	Fresh Water	WET	Sensor for Water, EC and Temperature sensor (introduced by Delta-T-Devices Ltd, UK)
IC	Irrigation Controllers	WUE	Water Use Efficiency

## REFERENCES

- Allen, R.G.; Pereira, L.S.; Raes, D.; Smith, M., 1999. Crop Evapotranspiration. Guidelines for Computing Crop Water Requirements. Food and Agriculture Organization of the United Nations (FAO), Irrig. Drain. Paper 56, Rome, Italy, 14 January 1999. <http://www.fao.org/docrep/X0490E/X0490E00.htm>.
- Anastasiou, A., Savvas, D., Pasgianos, G., Sigrimis, N., Stangellini, C. and Kempkes, F.L.K. 2009. Decision Support for Optimized Irrigation scheduling. Acta Hort. (ISHS) 807:253-258. [http://www.actahort.org/books/807/807\\_33.htm](http://www.actahort.org/books/807/807_33.htm).
- Balendonck, J., C. Stanghellini, J. Hemming, F. Kempkes, B. v. Tuijl. Farm Level Optimal Water management: Assistant for Irrigation under Deficit (FLOW-AID). ISHS Symposium on Protected Cultivation for Mild Winter Climates, Izmir, 2008.
- Chazbeck, A. 2008. Les effets du stress hydrique sur la croissance, la production, et l'efficience d'utilisation d'eau de l'aubergine (*Solanum melongena* L.). B.Sc. Thesis. Holly Spirit Univ., Faculty of Agricultural Sciences, Jounieh, Lebanon, 54 pages.
- Dominguez, A., E. Lopez-Mata, A. de Juan, A. Artigao, J.M. Targuelo, 2008. Deficit Irrigation under Water Stress and Salinity Conditions. The Use of the MOPECO Model. CIGR Int. Conf. of Agr. Eng., Conbea, Brazil Aug. 31 – Sept. 4, 2008.
- Food and Agriculture Organization of the United Nations (FAO). 2000. Deficit irrigation practices. Water Rep., 22, Rome, Italy. 6 January 09. <<http://www.fao.org/docrep/004/Y3655E/y3655e13.htm#m>>
- Food and Agriculture Organization of the United Nations (FAO). 2002. Crops and Drops - Making the best use of water for agriculture. Rome, Italy. 26 pg. 6 January 09. <http://www.fao.org/docrep/005/Y3918E/y3918e00.htm>
- Geerts, S. and D. Raes (2009). "Deficit irrigation as an on-farm strategy to maximize crop water productivity in dry areas." *Agricultural Water Management* 96(9): 1275-1284.
- Hilhorst M.A. 2000. A Pore Water Conductivity Sensor. *Soil Sci. Soc. Am. J.* 2000, 64, 1922–1925.
- Incrocci L., Incrocci G., Pardossi A., Lock G., Nicholl C., Balendonck J., 2009. The Calibration of WET-Sensor for Volumetric Water Content and Pore Water Electrical Conductivity in different Horticultural Substrates. Int. ISHS Symp. "Strategies towards Sustainability of Protected Cultivation in Mild Winter Climate", Antalya, 7-10 April 2008. Acta Hort.(ISHS) 807:289-294.
- Incrocci, L., P. Marzioletti, G. Incrocci, Balendonck J., S. Spagnol and A. Pardossi, 2010. The Application of the WET Sensor for the Management of Reclaimed Wastewater Irrigation in Container-Grown Ornamentals (*Prunus laurocerasus* L.). 3<sup>rd</sup> Int. Symp. on Soil Water Measurement Using Capacitance, Impedance and TDT, Murcia, Spain, April 7–9, 2010.
- Incrocci L., Pardossi A., 2009. Crop Stress Response Database version 1.2, 2 December 2009, available from: <http://www.flow-aid.wur.nl/UK/Activities/Crop+Response+Model/>
- Meron, M., Hallel, R., Bravdo, B. and Wallach, R. 2001. Tensiometer Actuated Automatic Micro Irrigation of Apples. Acta Hort. (ISHS) 562:63-69.
- Pardossi A., Incrocci I., Incrocci G., Marzioletti P. (2009a). What limits and how to improve Water and Nutrient Efficiency in Outdoor Container Cultivation of Ornamental Nursery Stocks. Int. Symp. "Soilless Culture & Hydroponics", Lima, Peru, 25-28 August 2008. Acta Horticulturae (ISHS) 843: 73-80.



- Pardossi A., Incrocci I., Incrocci G., Malorgio F., Battista P., Bacci L., Rapi B., Marzioletti P., Hemming J., Balendonck J. (2009b). Root Zone Sensors for Irrigation Management in Intensive Agriculture. *Sensors* 9, 2809-2835. Available at <http://www.mdpi.com/1424-8220/9/4/2809>
- Rousan, L. M., M. J. Rusan and J. Amayreh. 2008. Irrigation with Treated Wastewater under Full and Deficit Soil Moisture Conditions. Eds: Hashem Al-Mattarneh, Lariyah Mohd Sidek and Mohd Zamri Yusoff: Proceeding of the International Conference on Construction and Building Technology (ICCBT): Innovations in Water Resources and Environmental Engineering. Kuala Lumpur, Malaysia. (38): 405-416.
- Pruitt, W.O. and J. Doorenbos, 1977. Empirical calibration, a requisite for evaporation formulae based on daily or longer mean climatic data. ICID Conf. Evapotranspiration, Budapest, Hungary, May 26-28, 1977.
- Saliba, R. 2009. Monitoring the effects of soil water deficit on eggplants 'Solanum melongena L.' using the smart irrigation controller GP1. B. Sc. Thesis. Lebanese University, Faculty of Agricultural and Veterinary, Beirut, Lebanon, 71 pages.
- Tuzel, I.H., Y. Tüzel, M.K Meriç, G.B. Oztekin, R. Whalley, G. Lock, 2009. Response of cucumber to deficit irrigation. *Acta Hort.* 807:259-264. Available at <http://www.mdpi.com/1424-8220/9/4/2809>.
- Whalley, W. R., G. Lock, M. Jenkins, Tony Peloe, K. Burek, J. Balendonck, W. A. Take, I.H. Tuzel and Y.Tuzel, 2009. Measurement of Low Matric Potentials with Porous Matrix Sensors and Water-Filled Tensiometers. *Soil Sci. Soc. Am. J.*: Vol. 73: No.:6, Nov.-Dec. 2009.