

**Integrating Geo-information Models with
Participatory Approaches**
Applications in Land Use Analysis

Uday Bhaskar Nidumolu

Promoters:

Prof. Dr. A.K. Skidmore
Professor of Vegetation and Agricultural Land Use Survey
International Institute for Geo-information Science and Earth Observation
(ITC), Enschede and Wageningen University, The Netherlands

Prof. Dr. Ir. H. van Keulen
Professor, Plant Research International / Group Plant Production Systems
Wageningen University, The Netherlands

Co-promoter:

Dr. C.A.J.M. de Bie
Associate Professor
Department of Natural Resources
International Institute for Geo-information Science and Earth Observation
(ITC), Enschede, The Netherlands

Examining Committee:

Prof. Dr. A. K. Bregt, Wageningen University, The Netherlands

Prof. Dr. A. Veldkamp, Wageningen University, The Netherlands

Dr. K. Radhakrishnan, INCOIS, India

Prof. Dr. Ir. J.D. Van der Ploeg, Wageningen University, The Netherlands

**Integrating Geo-information Models with
Participatory Approaches**
Applications in Land Use Analysis

Uday Bhaskar Nidumolu

Thesis

To fulfil the requirements for the degree of Doctor on the authority of the Rector
Magnificus of Wageningen University, Prof. Dr. Ir. L. Speelman, to be publicly
defended on Thursday, December 2, 2004 at 15:00 hrs in the auditorium
at ITC, Enschede, The Netherlands

ISBN: 90-8504-138-4

ITC Dissertation Number: 117

International Institute for Geo-information Science & Earth Observation,
Enschede, The Netherlands

© 2004 Uday Bhaskar Nidumolu

Contents

| | |
|---|-----|
| Abstract | vii |
| Samenvatting | ix |
| Acknowledgements | xi |
| | |
| 1 General Introduction | 1 |
| 1.1 Setting of the current study | 1 |
| 1.2 Objective of the study..... | 3 |
| 1.3 Thesis Outline..... | 3 |
| References | 5 |
| | |
| 2 Review of a Land Use Planning Programme through the Soft Systems Methodology | 9 |
| 2.1 Introduction..... | 10 |
| 2.2 IMSD | 12 |
| 2.3 Soft Systems Methodology (SSM)..... | 14 |
| 2.3.1 Hard versus Soft Systems..... | 14 |
| 2.4 The SSM Review of IMSD..... | 15 |
| 2.4.1 Stages 1 and 2: The Problem Expression and Rich Pictures..... | 16 |
| 2.4.2 Stage 3: The Root Definition..... | 18 |
| 2.4.3 Stage 4: Conceptual Model..... | 18 |
| 2.4.4 Stage 5: Comparison of Stage 4 with Stage 2..... | 19 |
| 2.4.5 Stage 6: Definition of Feasible Desirable Changes..... | 21 |
| 2.4.6 Stage 7: Action to Solve the Problem Situation | 22 |
| 2.5 Conclusions | 25 |
| References | 27 |
| | |
| 3 Enhancement of Area-specific Land Use Objectives for Land Development | 35 |
| 3.1 Introduction..... | 36 |
| 3.2 Study area | 38 |
| 3.3 Data..... | 40 |
| 3.3.1 Map data..... | 40 |
| 3.3.2 Field data | 42 |
| 3.4 Method | 42 |
| 3.4.1 Analysis | 43 |
| 3.5 Validation of results | 45 |
| 3.6 Conclusions | 52 |
| References | 53 |

| | | |
|----------|---|------------|
| 4 | Identifying Options to Improve Irrigated Rice Cropping Systems through Comparative Performance Analysis | 57 |
| 4.1 | Introduction..... | 58 |
| 4.2 | Study Objective | 59 |
| 4.3 | Study Area | 59 |
| 4.4 | Study Method..... | 61 |
| 4.4.1 | Comparative Performance Analysis (CPA) | 61 |
| 4.4.2 | Field data collection | 61 |
| 4.5 | Descriptive statistics | 63 |
| 4.5.1 | Soils | 64 |
| 4.5.2 | Rice variety | 65 |
| 4.5.3 | Land preparation (ploughing and puddling)..... | 66 |
| 4.5.4 | Seed Rate..... | 66 |
| 4.5.5 | Transplanting days (with reference to January 1, 2002)..... | 66 |
| 4.5.6 | Fertiliser application | 66 |
| 4.5.7 | Weeding..... | 67 |
| 4.5.8 | Pests and diseases..... | 67 |
| 4.5.9 | Water shortage..... | 67 |
| 4.5.10 | Date of harvesting (length of growing season) | 68 |
| 4.6 | Multiple Regression..... | 68 |
| 4.7 | Yield gaps and yield constraints..... | 71 |
| 4.8 | Discussion and Conclusions..... | 71 |
| | References | 73 |
| 5 | Integrating Multiple Goal Linear Programming and Stakeholder Communication Matrix to generate Land Use options | 77 |
| 5.1 | Introduction..... | 79 |
| 5.2 | Study area | 81 |
| 5.3 | Method | 83 |
| 5.3.1 | The MGLP model for Pitlam Mandal | 83 |
| 5.3.2 | SCM development..... | 87 |
| 5.4 | Analysing the MGLP model and the Stakeholder Communication Matrix..... | 91 |
| 5.5 | Discussion and Conclusions..... | 91 |
| | References | 93 |
| 6 | Fuzzy Modelling of Farmers' Knowledge for Land Suitability Classification | 103 |
| 6.1 | Introduction..... | 104 |
| 6.2 | Fuzzy modelling | 105 |
| 6.3 | The case study area..... | 108 |

| | | |
|----------|---|------------|
| 6.3.1 | Background | 108 |
| 6.3.2 | Geography and agricultural practices | 109 |
| 6.3.3 | Farmers' knowledge of land suitability..... | 110 |
| 6.4 | FK-based fuzzy modelling of land suitability..... | 112 |
| 6.4.1 | Generation of fuzzy factor maps | 113 |
| 6.4.2 | Generation of land suitability maps..... | 117 |
| 6.4.3 | Evaluation of land suitability maps | 118 |
| 6.5 | Results | 119 |
| 6.6 | Discussion | 123 |
| 6.7 | Conclusions | 127 |
| | References | 128 |
| 7 | Synthesis | 133 |
| | Resume | 145 |

To my loving and affectionate parents

Abstract

Remotely-sensed data coupled with GIS-derived biophysical data have been key components in land use studies during the past decades. Natural Resource Managers relied on biophysically-oriented 'top down' approaches for the design of land and water management systems as a basis for regional planning. However, it is increasingly realised that the systems originating from these approaches often have limited success with land users. To generate practically applicable and attractive options for farmers, consideration of the aspirations of land users and their involvement from the plan formulation to the implementation stages is essential. The challenge for biophysical scientists involved in traditional land evaluation and land use planning therefore is the integration of socio-economic characteristics with biophysical data for land use analysis.

In this thesis we demonstrate some methods to integrate biophysical data with socio-economic variables with applications in agricultural land use analysis. Part of Nizamabad District of Andhra Pradesh State in India is considered for developing and testing the methods developed. First the study area is stratified as a pre-field work exercise for a focused land use analysis. Stratification of the land into categories on the basis of land use analysis objectives, such as crop management improvement, crop selection and conservation helped focus on these distinct areas with different analysis requirements. The relations between 'land' as a biophysical factor and its 'use' as a socio-economic factor were analysed using GIS techniques to spatially differentiate these categories. Two categories viz., Crop Management Improvement and Crop Selection were analysed further. Identifying yield-limiting factors in support of planning and extension agencies is the focus of study in areas identified for Crop Management Improvement. While traditional yield gap studies compared yields at research stations and in farmers' fields, we considered yield variability among farmers' fields in similar socio-economic and environmental conditions. In this situation, the yield gaps are mainly due to differences in management practices. What if?- scenarios, generated using the multiple goal optimisation modelling tool, were integrated with a stakeholder communication matrix (SCM) in the Crop Selection areas. SCM indicates the level of communication and information-sharing among key stakeholders in the district. The multiple goal model considered the aspirations of various stakeholders and the matrix presented the communication and information-sharing dynamics, understanding of which is essential for participatory land use analysis. Integration of the goal model with the SCM allowed identification of the possible bottlenecks in the implementation of the model results, allowing resource managers to initiate curative measures where required. Fuzzy modelling of farmers' perceptions of land suitability emphasised the need for biophysical planners to consider the views of farmers while formulating land

use options. The preference of farmers for crops was based on variables such as cropping season, soils and water availability. The study explores similarities and contrasts in the way scientists and farmers perceive land suitability.

The research feedback workshop conducted in the study area with the stakeholders was useful in terms of eliciting views on the relevance of the research to the users. The enthusiastic participation of the users, the demand for extending the study spatially to neighbouring districts and for the software developed to generate scenarios was encouraging.

Key words: Land use analysis, GIS, remote sensing, yield gaps, regression models, crop management improvement, crop selection, conservation, multiple goal optimisation model, stakeholder communication matrix, fuzzy modelling, soft systems methodology

Integratie van geo-informatie modellen met participatieve methoden: Toepassingen in analyse van landgebruik

Samenvatting

In de laatste decennia is gebleken dat de combinatie van via remote sensing technieken verkregen gegevens en biofysische informatie afgeleid uit GIS bestanden een essentiële component is binnen landgebruikstudies.

Regionale planning van land- en watergebruik gebeurt meestal via een “top down” benadering. Deze benadering blijkt echter lang niet altijd succesvol. Om praktisch toepasbare en aantrekkelijke mogelijkheden voor boeren te realiseren is het van wezenlijk belang om hun overwegingen en ideeën mee te nemen in de planning en implementatie van regionaal landgebruik. De uitdaging voor wetenschappers betrokken bij productie-ecologisch onderzoek, landevaluatie en landgebruiksplanning ligt dus in het integreren van sociaal-economische en biofysische factoren in landgebruiksanalyses. In dit proefschrift worden enkele methoden gedemonstreerd om deze integratie op een betere manier tot stand te brengen.

Het onderzoek, de ontwikkeling en het testen van de methoden, zijn uitgevoerd in een gedeelte van de deelstaat Andhra Pradesh in India. De eerste stap was het opsplitsen van het onderzoeksgebied in eenheden waarvoor in de landgebruiksanalyse verschillende doelstellingen nagestreefd worden, zoals verbeterde teeltmaatregelen, gewassenkeuze of bodembescherming. Op basis van deze analyses werd onderscheid gemaakt tussen gebieden met specifieke eisen op het gebied van methoden nodig voor planning en implementatie van landgebruik.

De ruimtelijke samenhang tussen “land” als biofysische factor en “landgebruik” als economische factor is onderzocht met behulp van GIS technieken.

Twee aspecten zijn in meer detail onderzocht: verbetering van teeltmaatregelen en gewassenkeuze. Voor het identificeren van betere teeltmaatregelen ter ondersteuning van voorlichtingsdiensten of planbureaus, is het van belang onderzoek te doen naar opbrengstbepalende factoren. In traditionele ‘yield-gap’-studies wordt meestal een vergelijking gemaakt tussen gewasopbrengsten op onderzoeksstations en opbrengsten behaald door boeren. In deze studie wordt een vergelijking gemaakt tussen de opbrengsten van verschillende boeren die opereren onder overeenkomstige sociaal-economische en ecologische omstandigheden. De verschillen in opbrengst kunnen dan voornamelijk worden toegeschreven aan verschillen in productiemethoden.

Voor de gebieden waarvoor gewassenkeuze als doelstelling was geselecteerd, zijn verschillende scenario's ontwikkeld waarin verschillende doelstellingen die boeren en andere belanghebbenden nastreven, kunnen worden geoptimaliseerd. Die optimalisaties zijn uitgevoerd met een lineair programmeringsmodel met meervoudige doelstellingen (MGLP). De resultaten van die scenario's zijn geïntegreerd met een matrix waarin de mate van communicatie en uitwisseling van informatie tussen de verschillende belanghebbenden wordt weergegeven (de zogenaamde "stakeholder communication matrix"). Dus, in het MGLP-model worden de consequenties voor de gewassenkeuze bekeken van de verschillende doelstellingen van de diverse belanghebbenden. En de "communicatiematrix" laat zien waar communicatie tussen de belanghebbenden en de mate waarin gezamenlijk gebruik gemaakt wordt van informatie mogelijke beperkingen vormen in het streven naar het bereiken van die verschillende doelstellingen. Inzicht hierin is essentieel voor effectief gebruik van de resultaten van landgebruiksstudies waarin alle belanghebbenden een rol spelen en meewerken.

Een andere modelleertechniek, genaamd "fuzzy modelling", is gebruikt om de perceptie van boeren met betrekking tot de geschiktheid van hun land voor bepaalde gewassen in kaart te brengen. Bij de ontwikkeling van landgebruiksplannen is het van groot belang om te weten hoe boeren zelf de geschiktheid van hun grond inschatten en niet alleen af te gaan op de resultaten van door onderzoekers geformuleerde modellen. Uit dit onderzoek bleek dat de voorkeur van boeren voor bepaalde gewassen gebaseerd was op karakteristieken zoals de groeiperiode van de gewassen, de kwaliteit van hun grond en de waterbeschikbaarheid. Deze studie illustreert de overeenkomsten en verschillen in de manier waarop wetenschappers en boeren aankijken tegen de geschiktheid van land voor bepaalde typen landgebruik.

De workshop die naar aanleiding van deze studie is gehouden in het onderzoeksgebied met de betrokken boeren en andere belanghebbenden leverde veel enthousiaste reacties op. De vraag naar uitbreiding van deze vorm van planning naar andere gebieden en naar de software die gebruikt is om de verschillende scenario's te ontwikkelen was groot. Deze reacties vormen een goede basis voor verdere uitbreiding en toepassing van deze methode.

Acknowledgements

This thesis is result of support by a number of people and organisations. I thank National Remote Sensing Agency (NRSA) and Department of Space, India for permitting leave to study and ITC, The Netherlands for the PhD fellowship. Prof Karl Harmsen believed in the utility of the IMSD programme and encouraged me to develop improved methods. He has been a source of constant support and guidance. Prof Andrew Skidmore, my ITC & University Promoter was most supportive and positive, always there when I needed. My morale always went up after our discussion meetings. It was a privilege. Prof Herman van Keulen, encouraging and supervising young researchers is an art and you have perfected it! As my University Promoter, I couldn't have asked for a better teacher. I can't thank you enough. Dr Kees de Bie, my Co-Promoter, constructively critical, supported me all the way through and made time when I needed despite a pressing time schedule, dank u wel.

Dr DP Rao, Dr K Radhakrishnan, Prof SK Bhan, Dr A Perumal at NRSA encouraged and supported me to start my PhD and consequently during the research work. You have been very kind, thank you. NRSA is acknowledged for permission to use IMSD data set of part of Nizamabad District. Discussions with Dr Herman Huizing, Dr David Rossiter, Dr Ali Sharifi, Prof Michael Stocking, Dr Mukund Rao, Dr Vinay Kumar Dadhwal, Dr Santiago Dogliotti, Marcel Lubbers, Dr Kamar Iqbal were very helpful. Colleagues at former Integrated Surveys division in NRSA viz., Dr SVCK Rao, Dr J Ramanamurthy, Dr YVS Murthy, G. Hanumantha Rao and Dr SK Subramanian were very supportive of my research effort. Thank you.

Prof Martin Hale, Dr Elisabeth Kusters (former Research Coordinator) and Loes Colenbrander made sure I had excellent research administration. Loes thanks also for helping format this book. Andries Menning for cover page design and Iris van Duren for the Samenvatting, thank you. Esther Hondebrink and Daniela Semeraro, thank you for your logistical support in the NRS department. Bettine Geerdink, Theresa van den Boogaard, Marie Chantal Metz, Thea de Kluijver, Marion Pierik, Frans Gollenbeek, thank you for your administrative support. Cecille Plomp, Ard Kusters, Harold Borkent, Gerard Leppink, Gerard Reinink thank you for your computer systems support. Carla Gerritsen, no document is difficult for you to procure, always helpful, thank you for your services at the Library.

Several fellow PhD students shared time with me and made friends, thank you. Thanks to support and camaraderie of my office-mates over the past few years: Javier Martinez, Pravesh Debba, Cheng Jianquin, Grace Nangendo, Chudamani Joshi, Istiak Sobhan and Richard Onchaga. Rodrigo Sicat supported me with his MSc research, thank you for your friendship. Devika Chitranayana, Andrew

Mapfumo and Haig Alfred Sawasawa, thank you for supporting me with field data collection. The Indian student community at ITC was very supportive, thank you.

Field work and institutional support was facilitated by NRSA (Dr Ranganath Naval Gund, Director) and the district Administration of Nizamabad (KV Satyanarayana, Project Director, District Rural Development Agency and DV Raidu, Collector). Several field level officials made the entire field data collection exercise participatory and fruitful one. But for the enthusiastic and whole-hearted participation of the farmers of Nizamabad, this work would have lost its essence. Thank you.

We made several friends during our stay at Enschede. Karl Harmsen and Vidya have become family to us. Arbind and Salina Tuladhar, Hans and Vasantha, Sebastian and Sabina Koneker, Hendrik Eijgelaar and Sigrid Posthuma, thank you for including us in your social life.

My parents back in India were a pillar of strength and took our absence in their stride. We know their blessings are always with us. My wife Bhanu and son Prasanna settled into Enschede life quickly without demanding a lot of my attention. They were my strongest support and their love and affection helped me go through this sometimes demanding period with ease. We have very pleasant memories of our stay in the Netherlands and we will carry the most beautiful memory personified with us, our daughter 'Shreya' who was born here in Enschede. Our siblings kept regular contact and made sure we didn't feel homesick. Thank you.

Chapter 1

General Introduction

1.1 Setting of the current study

Expanding human requirements and economic activities are placing ever increasing pressures on land resources, creating conflicts and resulting in sub-optimal use of both land and land resources. Land is a finite resource, while the natural resources it supports can vary over time and according to the management conditions and uses. A decline in land quality caused by human activities, has been a major global issue during the 20th century (Penning de Vries et al., 1998; Oldeman et al., 1991) and will remain high on the international agenda in the 21st century. The importance of land degradation among global issues is enhanced because of its impact on world food security and quality of the environment (Eswaran et al., 2001).

The UN Conference on Environment and Development (UNCED, 1992), reinforced by the Johannesburg Summit (United Nations, 2002) emphasized the need for better monitoring of the earth's natural resources, including land and water. Chapter 10 of Agenda 21 strongly recommends an integrated approach to the planning and management of land resources. This refers specifically to improving planning and management systems through strengthening information systems and technological capacity. Chapter 14, 'Sustainable Agriculture and Rural Development' (SARD), which refers specifically to land resource planning information and education concerning the development of databases and GIS, encourages integrated planning at watershed and landscape level to reduce soil loss and protect surface and groundwater resources.

This conference triggered the introduction of new concepts in land use planning (FAO, 1995), emphasising the important role of stakeholders' involvement in research supporting sustainable development (Parker et al., 2002). The recognition of the importance of intense communication with stakeholders as a means of increasing chances of scientific knowledge being used in decision making also evolved (Loevinsohn et al., 2002; Parker et al., 2002). Farming Systems Analysis (FSA) and Land Evaluation (LE) developed as complementary research methodologies. FSA viewed the farm and the rural household in a comprehensive manner, recognizing the interdependencies

between natural and human environments (van Ittersum et al., 2004). Gibbon (1994) identified two developments in FSA: (i) a focus on participation of farmers and the inclusion of farmers' knowledge and experimentation in the research process and (ii) development of techniques of agro-ecosystems analysis and their incorporation in rapid rural appraisal. Land Evaluation on the other hand was originally defined as the assessment of the suitability of land for human use in agriculture, forestry or for other purposes (van Diepen et al., 1991), as part of land use planning. Many countries developed their own systems of land evaluation. Summaries of a number of these systems are presented in "Approaches to Land Classification" (FAO, 1974) and in "Land Classifications" (Olson, 1974). One of the widely used systems is the USDA Land Capability Classification (Klingbeil and Montgomery, 1961). In the 1970's, it was realized that a more universal approach to LE problems was needed and "A Framework for Land Evaluation" was realized by FAO (FAO, 1976). While FSA's main focus is on current land use and possible improvements, starting at holding level, involving mainly agronomists and social scientists, LE's is on future and potential land uses with a strong methodological and bio-physical orientation (Fresco et al., 1992). An integrated LEFSA development and implementation for improving land use analysis and planning combining the strengths was suggested by Fresco et al. (1992). Based on previous experiences, increasingly calls are being made for multi-scale approaches and integration of natural and social sciences (cf. Röling, 2001; 1994a; van Ittersum et al., 2004). The *ecoregional approach* (Horton et al., 2002; Rabbinge, 1995) is an example of this view. As enunciated by Sayer and Campbell (2001, quoted by van Ittersum et al., 2004), since the beginning of the 21st century, integrated natural resource management (INRM) research is the notion that covers interdisciplinary research, aiming at sustainable management of natural resources, emphasizing both the role of human actors and socio-economic and biophysical research methodologies.

These ideas serve as a broad agenda setting for the current study. The land degradation situation in India: out of a total geographical area of 329 million hectares, about 57% has been estimated to be in various stages of degradation (Sehgal and Abrol, 1994) and the expected further decline in the arable land resource base from the present 145 million hectares to 123 million hectares by 2030, while the population is expected to increase from the present 1040 million to 1400 million over that period, creating an additional food grain requirement of 240 million tonnes (MOA, 1999) is the context in which the study is set. A number of initiatives to address these concerns were taken up by various governmental departments (Reddy and Rao, 1999; Yugandhar et al., 1999). One

of the initiatives was the large-scale geo-information project called 'Integrated Mission for Sustainable Development (IMSD)', covering an area of about 83 million ha. The project aimed at generating 'action' plans for land and water management to be consulted by the District administration.

1.2 Objective of the study

The IMSD approach is predominantly that of LE, where methodologically a biophysical approach is used for land use planning. The current study was motivated by the desire to move towards an integrated biophysical-socio-economic approach to land use analysis in support of land use policy formulation, building on the IMSD methodology, developed for applications at regional scale. The crucial question that came up was why do 'action' plans (suggesting alternate land and water management practices) have low acceptance rates among planners and farmers? The follow-up question was 'what improvements in the methods can be developed?'. The current research set out to critically analyse the current methods in land use planning in the IMSD approach to identify their weaknesses as a basis for development of improved methods. The study is application-driven with the explicit purpose that the results should have relevance to stakeholders and contribute to improvements in land use analysis, currently in the IMSD programme, but in a broader context to bridge the domains of remote sensing and GIS-derived (geo-information) bio-physical variables and socio-economic variables.

1.3 Thesis Outline

This thesis has been developed as a series of papers; each chapter can be read as a standalone unit. However, there is an underlying logic that connects the chapters (Figure 1.1).

Chapter 2 focuses on an analysis of the existing land use planning programme within IMSD, using a soft systems methodology (SSM). Applying the SSM in the context of a land use planning programme is rather innovative, as most previous studies have applied it in organisational and management contexts (Röling, 1994b). We argue that since *land* and *use* are *hard* and *soft* components of a system (land use planning programme), respectively, SSM would be an ideal tool for its analysis. From Chapter 3 onwards the focus is on development of methods for land use analysis.

Chapter 3 emphasises the need to stratify a study area based on different analysis requirements at regional level. The objective is to support the extension agencies focus on identified requirements. We developed a method that stratifies the study area into three classes based on *land* and its *use*, (i) crop management improvement (ii) crop selection and (iii) conservation. For example, for areas characterized by a predominant cropping system, in this case paddy rice, farmers could benefit from recommendations on crop management improvement to increase yields. In areas characterized by a mixture of crops, farmers could benefit from models that can generate what if?-scenarios, considering such factors as profit, labour, irrigation water, government policies, dietary preferences, and environmental impact. In areas that are identified for conservation, alternative sources of income for farmers that focus on conservation agriculture, such as agro-forestry or on activities such as livestock, have to be generated.



Figure 1.1. Linkages of Chapters

Following from the ideas developed in Chapter 3, Chapter 4 focuses on areas identified for crop management improvement and develops a method to study yield gaps in irrigated rice. Data collected from 55 farms surveyed, and data generated from interviews with farmers were analysed and a step-wise multiple linear regression model was developed identifying key variables contributing to the yield gap. We limited ourselves to studying yield gaps in rabi season rice as a demonstration of the method. However, in operational land use analysis, yield gaps for other seasons, such as kharif and summer, and other crops such as sugarcane, cotton, sorghum in the area need to be analysed.

Chapter 5 pertains to areas identified for crop selection. Multiple goal linear programming (MGLP) is used to generate what if?-scenarios in support of discussions among scientists, policy makers and farmers. The innovation is the integration of the MGLP model with a stakeholder communication matrix (SCM) to identify possible bottlenecks in implementation of the results of the MGLP model. While the MGLP model considers biophysical and economic criteria, the SCM analyses the social context in which the MGLP model results are to be considered.

In Chapter 6, we apply a fuzzy modelling approach to compare farmers' criteria for land suitability and that of scientists using GIS. The objective is to examine how farmers make decisions on land use. Such information is of utmost importance in the development of participatory land use analysis tools in support of land use policy formulation.

Chapter 7 presents the synthesis of the thesis.

References

- Eswaran, H., Lal, R., Reich, P.F., 2001. Land degradation: an overview. In: Bridges, E.M., I.D. Hannam, L.R. Oldeman, F.W.T. Penning de Vries, S.J. Scherr and S. Sompatpanit (Eds.). Responses to Land Degradation. Proc. 2nd International Conference on Land Degradation and Desertification, Khon Kaen, Thailand. Oxford Press, New Delhi, India.
- FAO, 1995. Planning for sustainable use of land resource. Towards a new approach. Background paper to FAOs Task Managership for Chapter 10 of Agenda 21 of the United Nations Conference on Environment and Development (UNCED). Prepared by Land and Water Development Division and approved by Interdepartmental Working Group on Land Use Planning, FAO, 60p.

- FAO, 1976. A framework for Land evaluation. FAO Soils Bulletin No. 22. FAO, Rome, Italy.
- FAO, 1974. Approaches to land classification. Soils Bulletin 22. FAO, Rome. 120 p.
- Fresco, L.O., Huizing, H.G.J., Van Keulen, H., Luning, H.A., Schipper, R.A., 1992. Land evaluation and farming systems analysis for land use planning. FAO working document, Rome, Italy/ITC, Enschede, The Netherlands/Wageningen Agricultural University, Wageningen, The Netherlands. 209 pp.
- Gibbon, D., 1994. Farming systems research/extension: background concepts, experience and networking. In: Dent, J.B., McGregor, M.J. (Eds.), Rural and Farming Systems Analysis–European Perspectives. CAB International, Wallingford, UK. pp. 3–18.
- Horton, D., Manicad, G., Andriessse, W., Neuman, F., Berdegule, J., Escobar, G., Schlooz, P., 2002. Organizing and Managing Ecoregional Programs: Analytical Description, Reviews, and Stakeholder Issues. The Hague: International Service for National Agricultural Research. 103 pp.
- Klingebiel, A.A. and Montgomery, P.H. (1961) Land-capability classification. Agricultural Handbook 210, Soil Conservation Service. U.S. Govt. Printing Office, Washington, D.C. 21 p.
- Loevinsohn, M.E., Berdegúe, J.A., Guijt, I., 2002. Deepening the basis of rural resource management: learning processes and decision support. *Agricultural Systems* 73, 3-22.
- MOA (Ministry of Agriculture, Government of India), 1999. Agricultural situation in India, New Delhi.
- Oldeman, R.L., Hakkeling R.T.A., Sombroek, W.G., 1991. World map of the status of human-induced soil degradation. An explanatory note. ISRIC/UNEP, 34 pp.
- Olson, G.W. (1974) Land classifications. *Search, Agriculture*, 4(7): 34 p. Cornell University, Ithaca, New York
- Parker, P., Letcher, R., Jakeman, A., 2002. The potential for integrated assessment and modelling to solve environmental problems: vision, capacity and direction. In: Costanza, R., Jørgensen, S.E. (Eds.), *Understanding and Solving Environmental Problems in the 21st Century. Toward a New, Integrated Hard Problem Science*. Elsevier, Amsterdam. pp. 19-39.
- Penning de Vries, F.W.T., Agus, F., Kerr, J. (Eds.), 1998. Soil erosion at multiple scales. Principles and methods for assessing causes and impacts. IBSRAM, Bangkok/CABI Publishing, Wallingford. 390 pp.
- Rabbinge, R., 1995. Eco-regional approaches, why, what and how. In: Bouma, J., Kuyvenhoven, A., Bouman, B.A.M., Luyten, J.C., Zandstra, H.G. (Eds.).

- Eco-regional approaches for sustainable land use and food production. Kluwer Acad. Publ., Dordrecht, the Netherlands. pp. 3-11.
- Reddy, P.L.S., Rao, K.P., 1999. Watershed Development Programmes in India: Experiences, Issues and Future Agenda. *Journal of Rural Development, India*, 18, 3, 335-358
- Röling, N.G., 1994a. Platforms for decision-making about eco-systems. In: Fresco, L.O., Stroosnijder, L., Bouma, J., van Keulen, H. (Eds.), *The Future of the Land; Mobilising and Integrating Knowledge for Land Use Options*. Wiley, Chichester, UK, pp. 386-393.
- Röling N., 1994b. Interaction between extension services and farmer decision making: new issues and sustainable farming. In: Dent, J.B., McGregor, M.J. (Eds.) *Rural and farming systems analysis: European perspectives*. CAB International, Wallingford. pp. 280-291.
- Röling, N.G., 2001. Gateway to the global garden: Beta/gamma science for dealing with ecological rationality. Eight Annual Hopper Lecture, Centre for International Programs, Univ. of Guelph, Guelph, Canada. 51 pp.
- Sayer, J.A., Campbell, B., 2001. Research to integrate productivity enhancement, environmental protection, and human development. *Conservation Ecology* 5(2), 32 [online] URL: <http://www.consecol.org/vol5/iss2/art32>.
- Sehgal, J., Abrol, I., 1994. *Soil degradation in India: Status and Impact*. Oxford and IBH Publication, New Delhi. ?? pp.
- UNCED, 1992. Agenda 21, Chapter 14, Paragraph 44, The Earth Summit, Rio de Janeiro.
- United Nations, 2002. Report of the World Summit on Sustainable Development. Johannesburg, South Africa, 26 August-4 September 2002.
- Van Diepen, C.A., Van Keulen, H., Wolf, J., Berkhout, J.A.A., 1991. Land evaluation: from intuition to quantification. *Advances in Soil Science* 15, 139-204.
- Van Ittersum, M.K., Rötter, R.P., van Keulen, H., de Ridder, N., Hoanh, C.T., Laborte, L.G., Aggarwal, P.K., Ismail, A.B., Tawang, A., 2004. A systems network (SysNet) approach for interactively evaluating strategic land use options at sub-national scale in South and South-east Asia. *Land Use Policy* 21, 101-113.
- Yugandhar, B.N., Venkateswarulu, J., Kochar, V., 1999. Watershed-based development in Arid and Semi-Arid areas of Andhra Pradesh. *Journal of Rural Development, India*, 18, 3, 471-504

Chapter 2

Review of a land use-planning programme through the soft systems methodology

Abstract

Traditional land use planning approaches relied significantly on biophysical data and followed a hierarchical top-down approach. The component of primary stakeholders as being critical to the success of implementing such plans is often ignored. In India, a large-scale geo-information project called “integrated mission for sustainable development (IMSD)” was undertaken in aid of land use planning. Biophysical data were generated at regional scale using remote sensing data and conventional survey methods. Land and water management plans have been developed for use by district level land use planning officials. However, it is observed that the acceptance rate of the plans by farmers is below the expectations of the land use planners. To understand the reasons, this paper applies the soft systems methodology to systematically analyse the programme and to suggest modifications in the existing procedures. The FAO guidelines for land use planning have been taken as a reference for evaluating technically the existing IMSD procedures. It is concluded that in the current approach the emphasis is predominantly on biophysical components with a low priority for the socio-economic factors. To increase the acceptance rate of the plans, it is argued that the socio-economic context has to be better integrated in the generation of the plans.

Keywords: Land use planning; IMSD; Soft Systems Methodology

Based on: Uday Bhaskar Nidumolu, Kees de Bie, Herman van Keulen, Andrew K Skidmore and Karl Harmsen. Review of a land use-planning programme through the soft systems methodology (*In Press: Land Use Policy*)

2.1 Introduction

Land use planning is the systematic assessment of land and water potentials for alternative land uses considering economic and social conditions in order to select and adopt the best land use options (FAO, 1993). Its purpose is to select and put into practice those land uses that will best meet the current needs of the people, while safeguarding resources for the future. The driving force in planning is the need for change, the need for improved management or the need for quite different pattern of land use dictated by changing circumstances (FAO, 1993). Planning to make the best use of land is not a new idea. Farmers have made plans, season after season, deciding what to grow and where to grow it. Their plans have been made according to their needs, their knowledge and the technology, labour and capital available. As the size of the cultivated area, the number of people involved and the complexity of the problems increase, so does the need for information and rigorous methods of analysis and planning (FAO, 1989). Land use systems are functionally complex i.e. many factors influence the manner land is used (Louckes, 1977). Biophysical, climatic, demographic, economic and political variables, all directly or indirectly influence land use practices (Turner II et al., 1995). Moreover, factors do not act independently, but form a web of interactions and feedback and these characteristics act on different temporal and spatial scales. Thus the FAO (FAO, 1993) pointed out the need for comprehensive new approaches in land use and development planning: "How people or nations use their land depends on complex, interrelated factors which include the characteristics of the land itself, economic factors, social, legal and political constraints and the needs and objectives of the land users. In order to make rational decisions, it is necessary to collect the right information about the physical, social and economic aspects of the land area in question; and to assess the land's relative suitability for different uses in the light of the needs and objectives of the land user and the community." The UNCED (1992) emphasised the role of stakeholders in land use planning which subsequently led to new concepts in land use planning by the FAO (1995). Several studies have been reported on participatory land use planning: Hahn (1998) on the community land management (CLM) approach for land conflict management through participatory process in Burkina Faso; Integrated Catchment Management (ICM) as stakeholder-oriented approach for natural resources management in Australia (Queensland Government, 1991); Integrated Systems for Knowledge Management in New Zealand (Allen et al., 1995); Hagman and Murwira (1994) on the participatory approaches for soil and water conservation in southern Zimbabwe; Kutter et al., (1997) on the

application of the new FAO approach to land use planning with a case study in Sierra Leone; World Bank (2002); Pimbert and Wakeford (2002) on farmer's response to Government's vision for 2020 in Andhra Pradesh, India. A number of case studies across the world are listed by World Summit on Sustainable Development focusing on the role of participation in planning and decision making as critical for success in sustainable development (WSSD, 2002) and Hinchcliffe et al., (1999). Reddy and Rao (1999), Sarma (1999), Srivastava (1999), Yugandhar et al., (1999) give elaborate and critical evaluation of the watershed management, land use planning and participation process operational in India; Pasteur (2002) on changing organisations for watershed management in India.

The importance of watershed development as a strategy of agricultural and overall rural development in rainfed areas has been recognised in India for the past several years. A number of Government Departments as well as NGOs and external agencies are involved in promoting watershed development projects in various rainfed areas (Planning Commission of India, 1997, 2002). However, an integrated approach to watershed programmes as a strategy for overall development of rainfed areas was initiated during the period 1975-83. Integrated watershed development programme as a movement for agricultural development in the country has been operationalised since the seventh five year plan (1987-92) (Reddy and Rao, 1999). The severe drought conditions prevailing in many parts of India during 1985-1987, prompted the Government of India to focus its attention on fostering sustainable use of land and water resources in order to increase available water resources for agriculture and thus alleviate the effect of drought, in particular, in the rainfed agricultural areas. One of the programmes initiated in this context was the Integrated Mission for Sustainable Development (IMSD). It is an advanced geo-information project, which was launched at the national level by the Department of Space, Government of India, in 1992. The IMSD is an example of an advanced land-use planning approach, using remote sensing data from Indian earth observation satellites as well as from conventional survey methods. The goal of the programme is to generate plans for land and water resources development for use by district level resources managers to advise farmers about optimal use of their lands.

The objective of this paper is to review the IMSD land use planning procedures through applying Soft Systems Methodology and discuss ways in which this and similar land-use planning programmes can be made more effective in terms of adoption by agricultural producers, conservation of soil and water resources and biodiversity, and impact on poverty alleviation in rural environments.

Quantitative information on the adoption of IMSD action plans is available on a very limited scale only. Therefore, the intention is to draw attention to the constraints rather than quantitative overview of constraints to the adoption of IMSD action plans. Firstly we describe the IMSD programme, secondly we describe the theoretical aspects of SSM, and thirdly we apply the SSM techniques to review the IMSD programme. Then we discuss results and draw some conclusions.

2.2 IMSD

Land and water management plans were prepared for 175 districts spread across all the states of the country, covering nearly 84 million hectares (25 %) of the country. Spatial databases on natural resource themes, i.e. land use, soil, slope, aspect and altitude, geomorphology, groundwater prospects, rainfall and climate, drainage, watershed and surface water body, transport network, and settlement location and village boundary, have been generated using temporal satellite remote sensing data (1:50,000 scale) and conventional survey and analysis methods (e.g. soil mapping using the USDA approach upto series level, with physical and chemical analysis of soils samples). Using GIS technology, the resource themes are integrated and analysed to arrive at management plans that focus on land and water resources development, i.e. on evaluating alternate land uses, based on resource potential, groundwater exploration and recharge, surface water harvesting and soil conservation (NRSA, 1995; 1999). The IMSD approach is given in Figure 2.1. Although these action plans and the associated geo-spatial databases have certainly contributed to watershed development and promoting the rational and efficient use of land and water resources, it is observed that the degree of implementation of the action plans and the degree of adoption of the land-use recommendations by the farmers is lower than expected. This view is also supported by the surveys and interviews conducted in the IMSD study areas by Puri (2003). Also, The IMSD (Figure 2.1) is typically a top-down approach and is limited by lack of participation at the grass root level (Kutter et al., 1997) and as Radhakrishnan (1999) opines “the need for spatial database and action plans did not originate from the *user* but the selection was made at higher levels of Government hierarchy”, a possible reason for a lower than expected acceptance rate among stakeholders at grass root level.

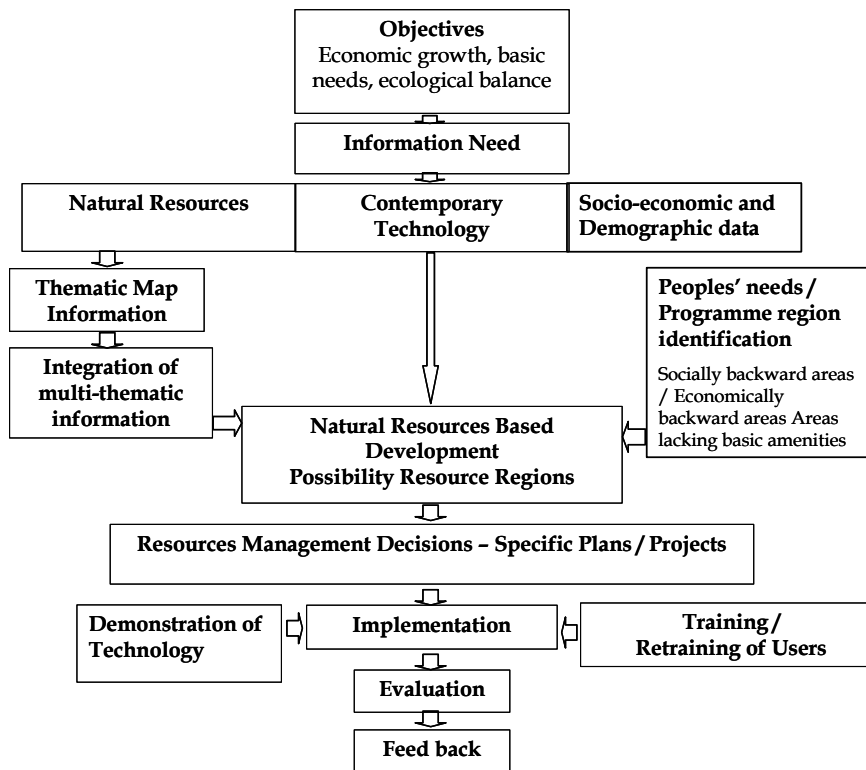

Figure 2.1. The IMSD Approach (NRSA, 1995)

The low acceptance and implementation of the land use plan is a cause for concern in the context of aggravating land degradation situation in India. Out of a total geographical area of 329 million hectares, about 57% of the land has been estimated to be in various stages of degradation (Sehgal and Abrol, 1994), where the term "land degradation" covers a wide range of degradation processes, including the loss of topsoil due to water or wind erosion, salinization or alkalinization of irrigated lands, nutrient depletion, degradation of the physical structure of the soil, and accumulation of toxic chemicals in the soil. Furthermore, the arable land resource base is expected to further shrink from the present 145 million hectares to 123 million hectares by 2030, whereas at the same time the population is expected to increase from the present 1040 million to 1400 million by 2030, with an additional food grain requirement of 240 million tonnes (MOA, 1999).

2.3 Soft Systems Methodology (SSM)

The SSM approach to problem solving has been developed by Peter Checkland (Checkland, 1981). It is an evolving methodology that has been steadily developed into a systemic process of enquiry. It is structured around a comparison between real-world problem situation and conceptual models of relevant systems of purposeful activity (Checkland, 1992). The concepts were developed through practical application and experience in a wide variety of complex managerial systems. The approach is designed to allow human element of such systems to be incorporated into system design work. Checkland's central argument is that conventional systems analysis, which he terms 'hard' systems analysis, has proved an inappropriate vehicle for investigating human systems. Valuable insights available from systems theory needed to be recast into a softer more interpretative methodology for investigating human activity (Reeve and Petch, 1999).

2.3.1 Hard versus Soft Systems

Hard systems thinking originated in engineering to generate solutions to technical problems. The soft systems approach emerged when modelling complex human activity processes. Hard systems assume that making a choice between alternatives to achieve a known objective can solve problems. Soft systems express a perceived problem in terms of structure and study the relation between the two (Checkland, 1992). Hard problems have clearly defined desirable goals (e.g. to manufacture a motor vehicle) and are characterised by these goals (Berry and Fourie, 2002); soft problems have obscure goals and if goals can be identified they may be in conflict with each other. Hard systems may give rise to a project with clearly defined objectives and deliverables and a defined project completion date (Berry and Fourie, 2002); soft systems are applicable when problem definition is itself a problem! The hard systems engineering approach involves a series of steps involving problem definition, choosing objectives, analysing alternative systems, prototyping and systems development and engineering (Checkland, 1992). The soft systems approach involves a seven-stage process of analysis, which uses the concept of human activity as a means of getting from finding out about the problem to taking action to improve the problem (Wilson, 1984). In the present case study, low acceptance of the land use plans by the users is the problem. Figure 2.2 shows the approach to SSM as developed by Checkland (1981) and adapted by Finegan (1994).

Based on the above discussion, the analysis of the IMSD land use programme adequately qualifies to be modelled through SSM. The following sections describe the method in detail through the predefined seven stages. The FAO guidelines (FAO, 1993) are used as a reference to review the IMSD planning programme. The FAO's Guidelines for land-use planning (FAO, 1993) and FAO's The Future of Our Land – Facing the Challenge (FAO/UNEP, 1999) have been taken as reference for the following reasons:

- a) The outcome of the Land Use Planning Approach of FAO is a culmination of several years of research by the international organisation in a number of countries across the world and in varied biophysical, social, political, economic and cultural settings (see Kutter et al., 1997 for details)
- b) The planning guidelines are an accumulated 'wisdom' of several experts drawn from the international community of scientists in this multi-disciplinary area.
- c) India (ref IMSD) has been an important contributor and a beneficiary of FAO efforts in the area of natural resources management and agriculture.
- d) The IMSD approach conceptually adopts the FAO approach to land evaluation.

2.4 The SSM Review of IMSD

The current IMSD model has a predominantly biophysical emphasis. In systems analysis terminology, biophysical data are referred to as "hard data" or as "the systematic component". In a land use planning process socio-cultural-political-economic data form another critical component. In systems analysis terminology, they are referred to as "soft data" or as "the systemic component". If the IMSD model integrates socio-economic variables, which is deemed appropriate, then the shift is from systematic to systemic i.e. from hard to soft systems.

The Soft Systems Methodology (SSM) is adopted to carry out the required analysis. The IMSD land use planning programme can be treated as a system whose main characteristics include interconnected parts, boundary conditions, emergence, sub-systems and processes. The interconnected parts comprise of the biophysical thematic data of the suggested land use model. The boundary conditions include e.g. scale or detail of the system, GIS layers that represent the full system, available technology, and technical manpower. Sub-systems cover operational aspects like mapping, integration, organization, logistics and

finance. Processes include feedback from the users; they control information flows between interconnected parts. The IMSD “system” can assumed to be embedded in an organizational setting consisting of the Central Government and its various agencies, the State and District Administrations, defining policies, guidelines, funding procedures, monitoring and evaluating mechanisms. The IMSD programme is reviewed over a seven-step SSM.

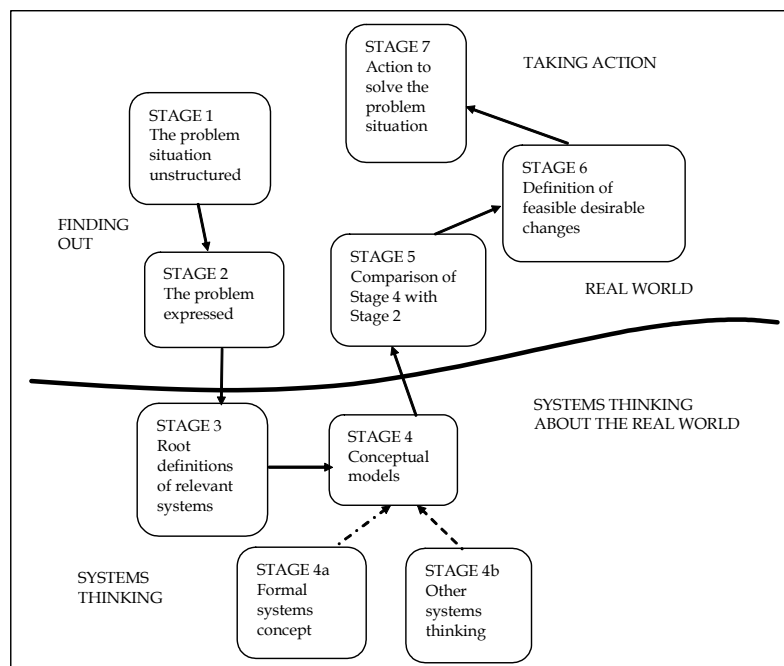

Figure 2.2. The Soft Systems Methodology (Finegan 1994).

2.4.1 Stages 1 and 2: The Problem Expression and Rich Pictures

The first two stages form the expression phase of the methodology and involve the examination of the background of the problem. This is expressed in the form of rich pictures (Finegan, 1994); Figure 2.3). Bell and Harper (1992) provide a list of techniques that an analyst might use during the expression phases of the methodology, including interviews with stakeholders, regular discussion groups, workshops and observation techniques. The intention should be to capture all relevant information about a problem: quantitative and qualitative, objective, subjective and official (Reeve and Petch, 1999).

Data available for these two stages comprise of the FAO Guidelines, IMSD reviews and related documents, interviews with stakeholders (with the IMSD team, District level officials and Farmers' groups) and weighted charts from stakeholders generated during the Participatory Rural Appraisal exercise during the course of this work conducted in an IMSD study area.

The rich picture for the case study is shown in Figure 2.3. It indicates inter-relationships among variables and process bottlenecks. A clear bottleneck is that integration of socio-economics with biophysical data is missing and that developed land use plans form no real input into rural development programmes.

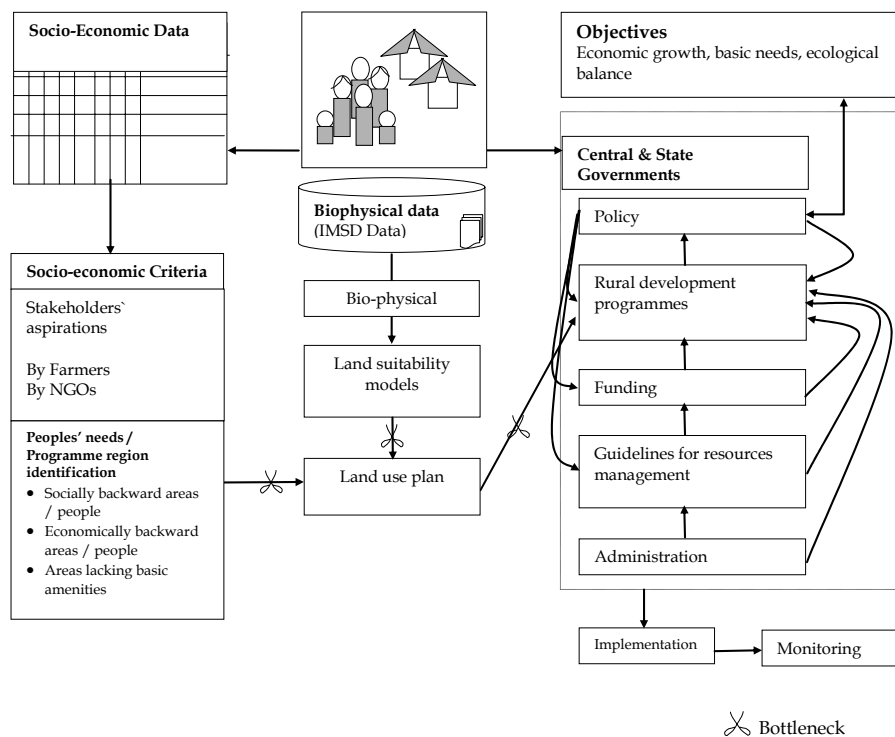

Figure 2.3. Rich Picture of the Case Study

2.4.2 Stage 3: The Root Definition

A root definition is essentially a sentence that describes, in an abstract way, the fundamental nature of a system when viewed from a particular viewpoint. As a guide to the construction of root definitions, (Checkland, 1981) provides the CATWOE elements by which he means that a complete root definition should identify the Client (C), the Actors (A), the Transformation (T), the Worldview (W), the Ownership (O) and the Environmental constraints (E) of the system (Reeve and Petch, 1999). In less formal terms, the CATWOE elements require that the root definition should state *who* is doing *what* to *whom*, and to whom are they *answerable*, what *assumptions* are made, and in *what* environment is it happening? (Avison and Fitzgerald, 1988 in Reeve and Petch, 1999; Table 2.1).

Two key stakeholders are considered for this study: the Government (read as IMSD data and 'action plan' developers) who represents both the Actor and Owner and the Farmer who is the Client. The root definitions for both stakeholders are given below:

- *Root Definition 1 (as seen by the government)*
Improved use of land by the farmers to mitigate drought with the help of land and water use plans developed by the IMSD, owned by the Central government in the framework of rural development policy, funding, guidelines and monitoring.

- *Root Definition 2 (as seen by the farmers)*
Improved use of land to mitigate impacts of drought in terms of increased incomes, decreased land degradation, increased food production, decreased soil loss, decreased surface run-off and increased ground water use with the help of land (water) use maps developed with their active involvement in plan formulation, so that the plan is owned by them to improve adoption and implementation in the framework of formulated rural development programmes of the government. This root definition was arrived at based on a PRA exercise conducted in the study area.

2.4.3 Stage 4: Conceptual Model

Based on the root definitions, the conceptual model is adapted from FAO (FAO, 1989), which is considered to be the most relevant with respect to the present case study. The FAO's core model is a ten-step approach incorporating the

various components of the problem situation, root definition and rich pictures. Each step in the conceptual model is composed of a series of sub-steps; details are given in Annexure 1.

2.4.4 Stage 5: Comparison of Stage 4 with Stage 2

This stage takes the methodology back to the 'real world' of the organisation and compares the conceptual model of the proposed system with aspects of the rich picture developed in stage 2 (Reeve and Petch, 1999). In the following paragraphs the comparison of the conceptual model and the existing model is made i.e. IMSD is theoretically derived from the FAO approach to land use planning, however, the deviation lies in the physical model, in this case implementation of land and water management 'action plans'.

- The establishment of goals viz., management of natural resources on a sustainable basis has been carried out in the existing IMSD model. The goal has been defined as "Mapping natural resources and their integration with socio-economic data to generate "site-specific action plans" to combat drought" (NRSA, 1995). It is well defined.
- The biophysical component relating to the database generation on natural resources has been adequately developed. There is limited degree of interactions with the 'line' department official machinery like with extension services, District Rural Development Agencies (DRDA), District Agriculture, Horticulture, Irrigation, Groundwater, Forestry, Animal Husbandry, Panchayat Raj (Village local self-governance Institutions) and Soil Conservation departments, Water Users Associations and Watershed Development Committees
- The people's role component is deficient to identify opportunities for change.
- Land-suitability aspects have been taken into account purely as a biophysical model while socio-economics of the study areas are not explicitly reflected in the outputs.
- A major deficiency appears in relation to the appraisal of alternatives (as a consequence of implementing the land use plan) with respect to

environmental impact, economic analysis, strategic planning and social planning.

- An important and critical insufficiency is in the area of integrating the diverse information and knowledge with respect to biophysical and socio-economic aspects into a negotiation support system.
- The work organisation has been systematically accomplished.

Table 2.1: CATWOE Analysis Applied to the IMSD Case

| | Elements | Description |
|-----------------|--|---|
| Clients | Farmers | The persons, or groups, who benefit from the outputs of the system |
| Actors | Government | People that are part of the system and carry out its functions |
| Transformations | Improved use of land | Land use modifications and/or conversions |
| World view | Land (water) use planning to mitigate drought | The view point from which the system is being considered |
| Owners | Government | Those who have the power to guide or support how the system performs |
| Environment | <i>Planning environment context viz., rural development policy, funding, guidelines, monitoring, politics; supplying conditions of land with its possible use capabilities; socio-economic context conditions by which optional land uses are supported and/or constrained</i> | Other systems with which the target system interacts and which impose constraints or pressures upon target system |

Figures 2.5 and Annexure 1.1 summarize further the step-wise comparison carried out between the conceptual model and the existing situation. The FAO sub-steps have been investigated as reported in Annexure 1. Note that the number of sub-steps differ by step. Figure 2.4 illustrates the number of matching and non-matching sub-steps when comparing the conceptual and the existing models. The match between the two decreases progressively from step 1 to step 6. At step 5, which is the biophysical component analysis (the core area of in IMSD) there is a balance between the number of matching and non-

matching sub-steps. The non-matching count peaks at steps 6 (appraisal of alternatives) and steps 7 and 8.

It can be seen from Annexure 1 that there is information flow between steps and sub-steps (first column). The output of a step or sub-step is an input into subsequent step and sub-step. If the step or sub-step is highlighted, it indicates that it has been accomplished in the IMSD programme. If the accomplished step contributes as input to an unaccomplished step then it is clear that required data is available but a procedure to utilise the data is missing. For example in Steps 5 and 7, the accomplished sub-steps outweigh the non-matching sub-steps indicating that the procedure to integrate these data is missing. However, in Step 6 the non-matching sub-steps outweigh the matching sub-steps. This is due to the fact that the input from the other sub-steps is low or entirely new inputs which have not been generated under the IMSD programme are required.

With reference to the above discussion, feasible/desirable changes in the IMSD programme are discussed in subsequent sections.

2.4.5 Stage 6: Definition of Feasible Desirable Changes

This stage assumes that from the comparison of the conceptual model with the actual situation as represented in the rich picture, a series of recommendations for change will emerge which will then need to be considered for action (Reeve and Petch, 1999).

Sustainable Land Management objectives, which capture the feasible and desirable changes, are given in a model proposed by de Bie (2000) and de Bie et al., (1995). Some of the feasible and desirable changes due to improved land use (see Level 1, Table 2.2) are decrease in land degradation, conservation of the environment, improvement in water quality, decrease of topsoil loss, decrease in surface water runoff, increase of the groundwater level, and increase in productivity leading to improved incomes.

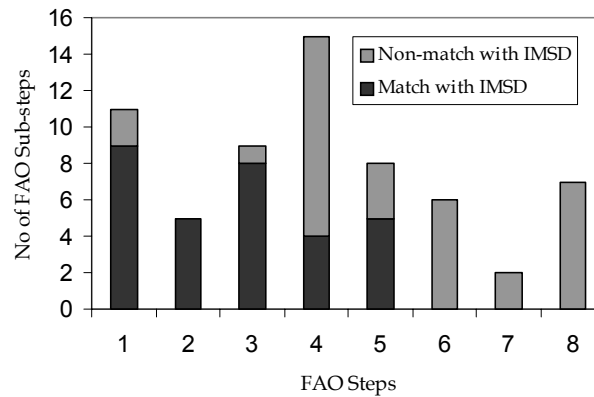

Figure 2.4. Comparative conformity diagram of FAO versus IMSD methods

Achievement of these objectives depends on the biophysical management as occurs at Level 1, i.e. at Field (LUS) Level. Decisions on that management depend in turn on the objectives and parameters at Holding Level (Level 2). These decisions in turn depend on Context Conditions (Level 3). Land use planning must consider these inter-dependencies. In case of IMSD, the plans are prepared at Level 3 and are meant to be implemented at Level 1. It is clear from Figure 2.5 that Holding Level (see dashed line in Figure 2.5) is clearly bypassed. However, it is understood that primary stakeholders at the Holding level, make actual decisions on their lands. Enhancing sustainable agriculture development requires insight in the dynamics of agriculture systems at both the holding and regional level. At holding level, insight is required in the way management affects the development of soil fertility, food security and incomes etc. At regional level, insight is required into the interactions of agro-ecological and socio-economic aspects (Struif Bontkes and van Keulen, 2003). The implementation then is carried out at the Field Level (Level 1).

2.4.6 Stage 7: Action to Solve the Problem Situation

Although theoretically land evaluation (hard systems) recognises that land use types are part of farm systems and therefore not independent, in practice (in this case the IMSD model), it only assesses the suitability of land use types for land units. Holding as a unit of decision-making or alternatives as required /identified by other stakeholders is not taken into account (soft systems). In a way it looks at land use at a (sub-) regional level, omitting the holding level (socio-economic factors). Many suitability assessments, although still relevant, are therefore less applicable for land use planning and certainly not fit for

implementation ((Polman et al., 1982, Fresco et al., 1992, Erenstein and Schipper, 1993 as quoted in Schipper, 1996).

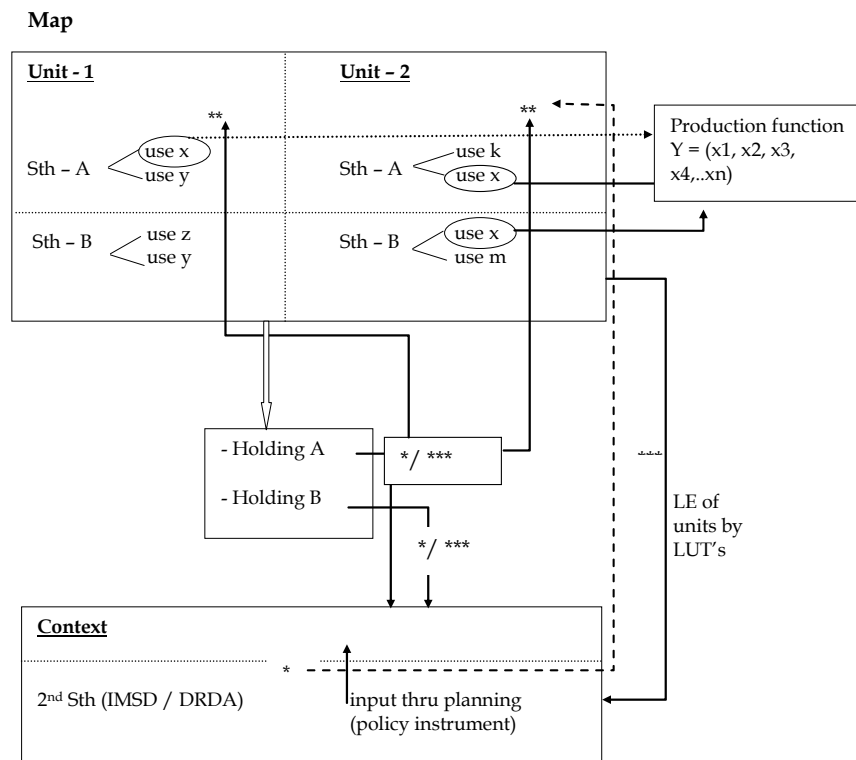

Sth = Stakeholder
 IMSD = Integrated Mission for Sustainable Development
 DRDA = District Rural Development Agency
 LE = Land Evaluation

LUT = Land Use Type
 * = Problem / requirement/needs/wants
 ** = Desirable key attributes values
 *** = Applying key attribute by LUT

Figure 2.5. Relationship between stakeholders, planners and their linkage to mapping units

Adoption of management plans depends on three fundamental factors viz., (a) Information and technology, (b) People's aspirations/participation and (c) Governmental policies (Skidmore, 1997). It is seen that in order to generate resource management plans in tune with the FAO approach (FAO, 1993; FAO/UNEP, 1999), identification of opportunities for change regarding steps iv to vii are essential. These Steps broadly relate to generating / gathering data for land evaluation in biophysical terms, to evaluate socio-economic aspects, to

assess and integrate stakeholders' aspirations, and to integrate these data to arrive at a resource management options.

Table 2.2: Functions in the model relate SLM-objectives to SLM-parameters at three hierarchical levels. The functions have the following form: [SLM-Objectives] = f [SLM-Parameters].

| 1. Land use system (LUS) level: (Land management takes place here) | |
|--|------------------|
| <p>SLM Objectives</p> <ul style="list-style-type: none"> • Achieve set benefits / yields targets • Minimize production variability • Conserve the environment, i.e.: <ul style="list-style-type: none"> - soil quality/quantity - water quality/quantity - nutrient balances - others | <p>=f</p> |
| <p>SLM Parameters</p> <ul style="list-style-type: none"> • Land conditions: <ul style="list-style-type: none"> - climate/weather - landform; soil - flora; fauna (incl. crops & livestock) - infrastructure • Management aspects dictated by land use purposes, e.g.: <ul style="list-style-type: none"> - maintenance of soil cover - use of conservation practices | |
| 2. Holding level: (The land user/holder acts here; basic decisions on SLM are made) | |
| <p>SLM Objectives</p> <ul style="list-style-type: none"> • Decisions on land management aspects, e.g.: <ul style="list-style-type: none"> - maximize the level of holding's profit/production - reduce costs and the use of non-renewable inputs - optimize labor use - conserve the environment | <p>=f</p> |
| <p>SLM Parameters</p> <ul style="list-style-type: none"> • Condition of fields within holding • Socioeconomic setting • Acquired SLM-knowledge • Tenancy arrangements by parcel • Indigenous LUS-knowledge • Flexibility, awareness, social acceptance • Household specifications • Off-farm economic activities | |
| 3. Local, regional, national, and global levels: (set the context for level 2) | |
| <p>SLM Objectives</p> <ul style="list-style-type: none"> • Create the required socioeconomic framework, e.g.: <ul style="list-style-type: none"> - maintain food security - generate wealth/welfare - preserve biological production potentials - protect rural landscapes - prevent excess production • Develop SLM technologies • Extension of SLM technologies • Improve tenancy arrangements land property rights | <p>=f</p> |
| <p>SLM Parameters</p> <ul style="list-style-type: none"> • LUS aspects • Holding aspects • Rural infrastructure and facilities • Incentives and barriers, quota, etc. • Input/product prices • Legislation, e.g. on: <ul style="list-style-type: none"> - land conversion rates / urbanization of good lands / use of marginal lands - inputs, implements, land use operations • Long-term development policies, support, and investment programs • Agricultural support systems and institutional structures • Trading opportunities | |

Based on the above, the general suggestions for modification of the IMSD approach are:

- a) Identify and involve stakeholders (at Holding Level) at the very early stages of plan making and ascertain their expectations from the proposed plan using for example well established methods like stakeholder analysis, participatory rural appraisal etc. It is seen from the analysis that the stakeholders (in this case, district officers at implementation level and the farmers who would be affected by implementation of the plans) are not adequately involved in preparation of the plans. Hence, their low acceptance level of the plans.
- b) Identify the gaps in the existing database with reference to those essential to realize the FAO Guidelines. Collect/generate (where possible) the missing information, e.g. data on stakeholders' knowledge, interests and aspirations and information on possible conflicts that may arise by plan implementation.
- c) Compare environmental, social and economic impacts of implementing alternative options. What if? scenarios must be generated as discussion tools among stakeholders. Impacts by maximizing or minimizing goal options must be evaluated using methods like multiple goal linear programming. For example scenarios could be generated where income is maximised and its impact seen on types of crops selected, labour employed, water used.
- d) Finally, develop a 'negotiation support system', which will be used by the stakeholders to generate 'their plans'. The tool provided must be user friendly and based on existing (biophysical) data and on data like stakeholder interests and aspirations.

2.5 Conclusions

This review has led to a number of findings. Some require still further study and elaboration.

A distinction has to be made between plans aimed at soil and water conservation on the one hand and those aimed at changing agricultural land-use practices on the other hand. The distinction should be made in terms of scale, farmer and stakeholder involvement, problem analysis and the development of viable alternatives, and the consideration of socio-economic

(including market) conditions and the policy (including subsidy) environment. In addition, it is important to consider indigenous knowledge, empowering weaker sections of the rural society, in particular women and tribal populations. At the district- and lower levels, there is a need to develop the skills and capabilities required to analyse spatial data and to develop land-use planning scenario's in an interactive and iterative way, with a view of reaching a consensus between farmers' objectives and the interests of other stakeholders. The action plans in the current IMSD approach do not seem to contain a clear economic analysis of the benefits of action plans to the local communities. If stakeholders at the local level would not benefit economically from the changes in land use proposed in the plans, they would not be motivated to accept the recommendations of these plans nor would they execute them. Therefore, in order to be adopted by farmers, the plans should address the immediate needs of the farmers, improve productivity of existing cropping patterns and farming systems, create off-farm income or, at least, indicate and quantify how farmers will benefit from adopting the land use plans. Typically, the degree of success of a land use plan is currently measured in terms of increased biomass (e.g., trees) in the watershed rather than through increased farmers' incomes (poverty alleviation), increased literacy rates, empowerment of women or any other, relevant socio-economic parameter. The spatial scales of the action plans (1:50,000) may be adequate for soil and water conservation plans, which relate largely to common (state-owned) land or land owned by larger landlords. However, for recommendations regarding changes in land-use by individual farmers, a scale of 1:50,000 would be too small. Farmers need to be able to clearly see their own property on the map. With plot sizes typically being <2 hectares, one would need map scales in the range of 1:5,000 to 1-10,000 to enable farmers to clearly identify their plots and adopt land use options.

In summary, IMSD mission has been successful to the extent of creating a land evaluation database for a considerable extent of the country. It has a predominantly biophysically orientation and coupled with a top-down planning approach suffers from lack of adoption by stakeholders. The soft systems review approach is relevant for land use planning models such as IMSD where a convergence of soft and hard systems occurs and is particularly useful for organizational environments where success essentially depends on considering human components adequately. A change from a predominantly biophysical approach of planning to an integrated biophysical-socio-economic approach wherein all stakeholders participate in making the plan is required. Only an integration of the soft and hard systems will establish a planning

framework that will enable stakeholders to manage their natural resources in a sustainable way. The experiences and results of this study could be relevant to similar land use planning programmes operating in several developing countries.

In the next chapter, a case study is presented which builds on ideas developed in this chapter (specifically related to Step-4 of the FAO guidelines). The relations between *land* and its *use* are investigated as a pre-field exercise to identify areas with specific land use analysis objectives such as Crop Management Improvement (CMI), Crop Selection and Conservation. These objectives are then assessed in the field with the stakeholders' perceptions, with statistical and biophysical data.

References

- Allen, W.J., Bosch, O.J.H., Gibson, R.G., Jopp, A.J., 1996. Co-learning our way to sustainability: an integrated and community-based research approach to support natural resource management decision-making. In: El-Swaify, S.A., and Yakowitz, D.S. (Eds.). *Multiple Objective Decision Making for Land, Water and Environmental Management*. Lewis Publishers, Boca Raton
- Avison, D.E., Fitzgerald, G., 1988. *Information systems development: Methodologies, Techniques and Tools*. Oxford: Blackwell.
- Bell, S., Wood-Harper, T., *Rapid Information systems development: A non-specialists guide to analysis and design in an imperfect world*, London: McGraw-Hill Book Co, 1992.
- Berry, M., Fourie, C., 2002. Analysing cadastral systems in uncertain situations: a conceptual framework based on soft systems theory. *International Journal of Geographical Information Science* 16(1), 23-40.
- Checkland, P., 1992. From framework through experience to learning: the essential nature of action research. In: Bruce, C.S., Russell, A. L. (Editors), *Second World Congress on Action Learning*. ALARPM Ass Inc, University of Queensland, Brisbane, Australia, pp. 14-17.
- Checkland, P.B., 1981. *Systems thinking, systems practice*. John Wiley and Sons, London.
- de Bie, C., 2000. *Comparative performance analysis of agro-ecosystems*, Wageningen University, Wageningen.
- de Bie, C., Beek, K., Driessen, P., Zinck, J., 1995. Towards operationalisation of soil information system for sustainable land management, Brazil Soil conference, ITC, Enschede, pp. 20.

- Erenstein, O.C.A., Schipper, R. A., 1993. Linear programming and land use planning: a case study of Matara district, Sri Lanka. 28, Wageningen Economic Studies, Wageningen.
- FAO., 1989. Guidelines for Land use planning. FAO, Rome.
- FAO., 1993. Guidelines for Land use planning. Development Series 1. FAO, Rome.
- FAO, 1995. Planning for sustainable use of land resource. Towards a new approach. Background paper to FAOs Task Managership for Chapter 10 of Agenda 21 of the United Nations Conference on Environment and Development (UNCED). Prepared by Land and Water Development Division and approved by Interdepartmental Working Group on Land Use Planning, FAO, 60pp.
- FAO/UNEP., 1999. The Future of Our Land: Facing the Challenge. FAO, Rome.
- Finegan, A., 1994. Soft systems methodology: an alternative approach to knowledge elicitation in complex and poorly defined systems. Complexity International 1.
- Fresco, L. O., Huizing, H., van Keulen, H., Luning, H., Schipper, R. A., 1992. Land evaluation and farming systems analysis for land use planning: FAO Working document, ITC/Wageningen Agricultural University/FAO, Enschede, Wageningen, Rome.
- Hagman, J., Murwira, K., 1994. Indigenous soil and water conservation in southern Zimbabwe: a study on techniques, historical changes and recent development under participatory research and extension. Project Research Report 13, Department of Agricultural and Extension Services (AGRITEX), Zimbabwe and GTZ.
- Hahn, A., 1998. Institutionalising participation on village level - the example of one community in the south-west Burkina Faso. In: Scherler C and Forster R (Eds.). Beyond the toolkit: experiences with institutionalising participatory approaches of GTZ supported projects in rural areas. Eschborn: GTZ
- Hinchcliffe, F., Thompson, J., Pretty, J., Gujit, I., Shah, P., 1999. Fertile Ground - The impacts of participatory watershed management. Intermediate Technology Publications Ltd, Southampton Row, London. 385pp
- Kutter, A., Nachtergaele, F., Verheye, W., 1997. The new FAO approach to land use planning and management and its application in Sierra Leone. ITC Journal 3/4, 278-283.
- Louckes, O., 1977. Emergence of research on agro-ecosystems. Annual Review of ecology and systematics 18, 173-192.
- Ministry of Agriculture, Government of India (MOA), 1999. Agricultural situation in India, New Delhi.

- NRSA., 1995. IMSD Technical Guidelines. NRSA, Hyderabad.
- NRSA., 1999. Integrated Mission for Sustainable Development (IMSD): A national endeavour to reach the benefits of space technology to the common man. National Remote Sensing Agency (NRSA), Hyderabad. 8 pp.
- Pasteur, K., 2002. Changing Organizations for Watershed Management in India: from policy to practice Lessons for Change in Policy and Organizations, No. 4, Brighton: Institute of Development Studies. University of Sussex, Brighton. 28pp
- Planning Commission, Government of India, New Delhi. 1997. Report of the Committee on Twenty-five Years Perspective Plan for the Development of Rainfed Areas, 224pp + Annexure I
- Planning Commission, Government of India, New Delhi. 9th Five Year Plan (1997-2002), Vol 2.
<http://planningcommission.nic.in/plans/planrel/fiveyr/9th/vol2/v2c4-1-1.htm> (accessed on March 3, 2004)
- Polman, F.J., Samad, M., Thio, K.S., 1982. A demonstration of resource based socio-economic planning in Matara district. 1, Agrarian Research and Training Institute, Colombo, Sri Lanka.
- Pimbart, M.P., Wakeford, T., 2002. Prajateerpu: A Citizens jury/scenario workshop on Food and Farming Futures for Andhra Pradesh, India. IIED publication. 80pp
- Puri, S.K., 2003. Participation in GIS for Land Management in India: Problems and Prospects. In: Laukkanen, S and Sarpol, S (Eds.). Proceedings of the Information System Research Seminar in Scandinavia (IRIS'26). August 9-12, 2003.
- Queensland Government. 1991. Integrated Catchment Management: A strategy for Achieving Sustainable and Balanced Use of Land, Water and related Biological Resources. Queensland Department of Primary Industries, Brisbane, Australia.
- Radhakrishnan, K., 1999. Some Strategies for the Management of Indian Earth Observation System. PhD Thesis. The Indian Institute of Technology, Kharagpur, India
- Reeve, D., Petch, J., 1999. GIS, Organisations and People, A Socio-technical approach. Taylor and Francis Ltd, London.
- Reddy, P.L.S., Rao, K.P., 1999. Watershed Development Programmes in India: Experiences, Issues and Future Agenda. Journal of Rural Development, India, 18, 3, 335-358

- Sarma, J.S., 1999. People's Participation and Community Organisations in Management of Watersheds. *Journal of Rural Development, India*, 18, 3, 421-438
- Schipper, R. A., 1996. Farming in a fragile future: Economics of land use with applications in the Atlantic Zone of Costa Rica, Wageningen Agricultural University, Wageningen.
- Sehgal, J., Abrol, I., 1994. Soil degradation in India: Status and Impact. Oxford and IBH Publication, New Delhi.
- Skidmore, A., 1997. World's Apart. *ITC Journal*, 3/4, 240-245.
- Srivastava, O.N., 1999. Participatory Planning and Management of Watershed Projects - Some Considerations. *Journal of Rural Development, India*, 18, 3, 381-394
- Struif Bontkes, T., van Keulen, H., 2003. Modelling the dynamics of agricultural development at farm and regional level. *Agricultural Systems*, 76, 379-396.
- Turner II, B.L., Skole, D.L., Sanderson, S., Fischer, G., Fresco, L.O., Leemans, R., 1995. Land use and land cover change. Science Research Plan. IGBP Report no 35 and HDP report no 7, Stockholm and Geneva.
- UNCED, 1992. United Nations Conference on environment and Development, Agenda 21, Chapter 14, paragraph 44, The Earth Summit, Rio de Janeiro.
- Yugandhar, B.N., Jagarlapudi, V., Kochar, V., 1999. Watershed-based development in Arid and Semi-Arid areas of Andhra Pradesh. *Journal of Rural Development, India*, 18, 3, 471-504
- Wilson, B., 1984. Systems: Concepts, Methodologies, and Applications. John Wiley & Sons, Brisbane.
- World Bank, 2002. Building Institutions for Markets. World Development Report 2002. Oxford University Press, Oxford, UK. 249pp
- WSSD, 2002. World Summit for Sustainable Development, Johannesburg, South Africa. 26 August - 4 September, 2002. http://www.Johannesburgsummit.org/html/sustainable_dev/sustainable_dev.html) accessed on March 4, 2004

Annexure 1.1. FAO Guidelines for Land use Planning versus IMSD

 = IMSD Match

| Steps that provide needed inputs | FAO Step. | Description | Output |
|----------------------------------|-----------|--|---|
| 1. Establish Goals | | | |
| Problem area, Govt policy etc | 1.1 | Define the planning area | Nature and extent of the study area |
| | 1.2 | Contact the people involved | Nature and severity of problem, history etc |
| | 1.3 | Acquire the basic information about the area | General overview of the problems |
| 1.2 | 1.4 | Establish the Goals | Land and water management |
| 1.2 1.3 | 1.5 | Make a preliminary identification of problems and opportunities | Land degradation, drought prone, under / over exploited etc |
| 1.2 1.3 | 1.6 | Identify constraints on implementing improvements | Bio-physical, Social, political, policy, cultural factors |
| 1.2 1.3 1.5 | 1.7 | Establish the criteria for making decisions on land use | Land degradation, wastelands, soil/water conservation etc |
| 1.3 | 1.8 | Set the scope of the plan | Plan contains suggestions for land and water management; land suitability for given use etc |
| | 1.9 | Set the planning period | Budgetary year etc |
| | 1.10 | Agree on the content and format of the plan | Land and water management / maps, tables reports etc |
| | 1.11 | Decide operational questions | Logistics, manpower, field visits, travel etc |
| 2. Organise the work | | | |
| | 2.1 | List the planning tasks and activities | |
| | 2.2 | Decide the sequence of tasks | |
| | 2.3 | Draw up a work plan for the project as whole | |
| | 2.4 | Draw up individual, personal work plans | |
| | 2.5 | Allocate money and equipment | |
| 3. Analyse the problems | | | |
| | 3.1 | Collect data on the existing situation; Where possible compile maps | Database on: <ul style="list-style-type: none"> • population • land resources • employment and income • present land use • production and trends • infrastructure Sources: <ul style="list-style-type: none"> • maps • satellite imagery • air photographs • censuses • departmental records |
| 1.3 | 3.2 | Identify and map <ul style="list-style-type: none"> • land units • land use systems | Information (spatial / non-spatial) |
| | 3.3 | Identify problems of land use: | |
| 1.1 1.2 1.5 | 3.3.1 | Nature and severity, land units and land use systems affected | Land degradation, under / over exploitation of available resources etc |
| 1.2 1.3 | 3.3.2 | Analysis of causes | Soil erosion due to agriculture on steep slopes, soil degradation due to soil salinity etc |

Review of a land use-planning programme

| | | | |
|---|----------------|--|--|
| 1.2 3.1 | 3.4 | Interviews with: <ul style="list-style-type: none"> • Land users • Local leaders • Extension staff • Agencies Field reconnaissance | Clarifications on problems, aspirations / expectations, possible solutions |
| 1.1 1.2 1.5 1.6 1.8 | 3.5 | Prepare problem statements | |
| 4. Identify opportunities for change | | | |
| 4.1 Opportunities | | | |
| 1.2 1.3 3.4 | 4.1.1 | People | Aspirations, participation, labour, skills etc |
| 1.5 3.1 3.2.1 3.2.2 3.3 | 4.1.2 | Land | Underdeveloped regions, unexploited resources |
| 3.4 4.1.1 | 4.1.3 | Crops and land uses (Crop Selection/ Conservation)) | Feasibility of land use conversions as the existing use may not be relevant |
| | 4.1.4 | Improved technology (Crop Management Improvement)) | Feasibility of e.g. improving fertilizer use, pesticides use, and drainage or irrigation practices |
| | 4.1.5 | Economic opportunities | Feasibility of using new sources of capital, new or improved markets, changes to price structures, improved transport facilities etc. |
| | 4.2 | Options for change (Crop Selection) | |
| | 4.2.1 | Non-land use planning options : Population, food aid | |
| 3.1 3.2 3.3.2 | 4.2.2 | Allocations of land use | |
| 3.4 | 4.2.3 | New Land uses A complete change of land use | |
| 1.2 3.3.2 3.4 | 4.2.4 | Improvements to land use types (Extension services, improved infrastructure and services) | |
| | 4.2.5 | Standards Planning guidelines or limits | |
| | 4.3 Procedures | | |
| | 4.3.1 | Focus on questions regarding what action can be taken within the plan | Integration with existing plans |
| 3.1 3.2 3.3.2 3.4 | 4.3.2 | Consider alternative land use strategies | Identification of alternatives between extremes viz., no change - maximum production - minimum public investment - maximum conservation - maximum equity |
| | 4.3.3 | Identify a range of possible solutions | Identification of solutions viz., selecting types of production: commercial, subsistence or combination of both. Production/conservation. Self reliance / outside investment |
| 1.6 1.8 3.3 3.4 | 4.3.4 | Develop options within extremes Moderate the maximum range of options by social imperatives, budgetary and administrative constraints, the demands of competing land uses and an initial assessment of land | |
| 5. Evaluate Land suitability | | | |
| 1.3 1.6 3.1 3.2 3.3.2 | 5.1 | Description of promising land use types | Detailed account of potential areas for specific land use |
| 3.2.1 3.2.2 | 5.2 | Selection of land qualities and land characteristics | Table with combinations of the different resources |

| | | | |
|--|-----|--|--|
| 3.2.1 3.2.2 | 5.3 | Mapping of land units and their characteristics | Spatial distribution |
| 4.3.2 4.3.3 5.1 | 5.4 | Setting limiting values | Boundaries defined based on the potential of the existing resources |
| 3.3.1 3.3.2 3.4 4.1.1 4.1.2 5.1 5.3 | 5.5 | Matching land use with land | Gaps and limitations in the existing land use system |
| 4.1.2 5.1 5.2 | 5.6 | Qualitative and quantitative land evaluation | Identification of critical importance of certain areas, estimates of crop yields etc |
| 5.3 5.5 | 5.7 | Land suitability classification | Comparison of requirements of land-use types with properties of land units |
| | 5.8 | Planning for research | Scope for doing research on the information deficiencies found during this step |
| 6. Appraise alternatives | | | |
| 5.4 5.5 | 6.1 | Environmental impact | Compare the consequences of alternate land management system |
| | 6.2 | Economic analysis | Economic consequences of the alternate land management strategy |
| | 6.3 | Limitations of economic analysis | |
| 1.2 1.6 3.3.1 4.1.1 4.1.2 4.3.2 6.2 | 6.4 | Strategic planning | Critical importance of land for specified uses. Realistic alternative scenarios of future needs devised and compared with estimates of the potential production with the target production |
| 1.2 1.6 3.1 3.5 | 6.5 | Social Planning | The effects of proposed changes on different groups of people |
| 3.4 4.1.1 4.1.4 4.2.2 4.2.4 5.5 | 6.6 | Interface of land use planning with rural development planning | The required investments in infrastructure, services etc as result of the implementation of the alternate land management plan |
| 7. Choose the best option | | | |
| 1.2 1.7 1.8 3.2.1 3.2.2 3.3.1 3.3.2 3.4 4.1.1 4.1.2 4.2.5 4.3.2 5.1 5.2 5.3 5.4 5.5 5.6 | 7.1 | Planning as a decision support system | Assemble and summarise the facts (results from previous steps) needed to make an informed decision. Decision Support System |

Review of a land use-planning programme

| | | | |
|---|-----|---|--|
| | 7.2 | Land use allocation, recommendation and assistance | Policy guidelines for new 'allocated' or existing land uses; land units delineated by land survey and land use types designed to be sustainable and economically viable within the planning area |
| 8. Prepare land use plan | | | |
| 1.3 3.2.1 3.2.2 3.4 5.1 5.2 5.5 | 8.1 | Preparation of maps - the basic or master land use plan and supporting maps | |
| | 8.2 | Set out the land use allocations and recommendations based on the preferred option selected in Step 7 | |
| 2 | 8.3 | Set targets for achievement, by land use type, area and agency. Specify how the will be reached | Details on what should be done, how should it be done and reasons for taking the decision |
| 1.11 2 | 8.4 | Logistic planning | |
| | 8.5 | Staffing, timing and costs | |
| 1.10 | 8.6 | Format of the plan | Executive summary, main report, maps and appendixes |
| | 8.7 | Public relations material | |
| 9. Implement the plan | | | |
| 10. Monitor revise the plan | | | |

Chapter 3

Enhancement of area-specific land use objectives for land development

Abstract

Maps of land use classes and soil series were analysed to identify areas having specific priorities with respect to agricultural land use analysis. Remote sensing data supported by field investigations was used to generate land use and soil maps. Present relationships between soils and associated land cover/use are analysed and patterns in these relationships are identified using GIS techniques. Relationships observed on the basis of *a priori* knowledge of the area and the available statistics are compared and these relationships in the field and through interviews with farmers are correlated. This allows three land use analysis objectives to be formulated: Crop Management Improvement, Crop Selection and Conservation. The results can be used to focus the efforts of planning and extension services in the area. The method was tested using a participatory rural appraisal in eighteen villages in which the areas for the three land use analysis objectives were identified. The findings are that the areas identified for Crop Management Improvement require knowledge about management practices for a specific crop to optimise yield and water use. Most areas identified for Crop Selection are occupied by smallholder subsistence farmers with insufficient water for irrigation, and lack of contact with the extension service. In these areas, identifying suitable crops to minimise risk and allow subsistence for the resource-poor farmers may be the priority. In areas identified for Conservation the question to be addressed is whether to grow a crop at all, or to encourage alternative activities.

Key Words: Land use; soils; land use objective; Conservation; Crop Management Improvement; Crop Selection; GIS; remote sensing.

Based on: Uday Bhaskar Nidumolu, Kees de Bie, Herman van Keulen and Andrew K Skidmore. (2004). Enhancement of area-specific land use objectives for land development. (*Land Degradation and Development, Volume 15, Issue 5, Pages 513 - 525*)

&
In: Proceedings of XXth ISPRS Congress, Istanbul, Turkey, 12-23 July, 2004

3.1 Introduction

Biophysical conditions and in particular soil conditions are considered important determinants of land use and receive ample attention, both in land use analysis and in analysis of actual land use patterns (Ravnborg and Rubiano, 2001). Land use refers to a series of operations on land, carried out by humans, with the purpose to obtain products and/or benefits through using land resources (de Bie, 2000). Human resource management strategies, characterized by the arrangements, activities and inputs to produce, change or maintain a desired land cover (Di Gregorio and Jansen, 1998) for arable farming and livestock grazing, significantly influence land use (Nielsen and Zobisch, 2001). Land use, defined in this way, is linked directly to the actions of people in their environment. The general assumption is that land use decisions are primarily driven by socio-economic-cultural considerations of land users. Through experience, often going back generations, farmers have developed land use systems that are well adapted to the potentials and constraints of their land (Cools et al., 2003). It is also assumed that farmers, if they have lived long enough in an area, know the spatial distribution of 'good soils' and the distribution of all soils of different degrees of suitability for production (Messing and Fagerström, 2001). Ravnborg and Rubino (2001) quoting Talwar (1996) and Talwar and Rhoades (1998) state that many studies provide evidence of farmers' detailed knowledge of their soils and of their ability to translate this knowledge into agronomic management options. Hence, where land use systems are being practiced *not* in accordance with the potentials or the suitability of the land, these practices can often be traced back to socio-economic factors as discussed by FAO (1976) and Rossiter and van Wambeke (1993). This is also in agreement with Daba's (2003) observation that in addition to climate, inherent soil properties, topography, vegetation cover and other environmental factors, the socio-economic conditions of farmers can play a significant role in preventing or promoting land degradation. Understanding the relations between socio-economic factors, human use of the land resources and their degradation is essential for the development of appropriate and sustainable land-use systems (Nielsen and Zobisch, 2001 quoting Hare, 1985; Roe et al., 1998).

The present study is part of an ongoing land use planning programme called the 'Integrated Mission for Sustainable Development (IMSD)' in India. Databases on land use/cover, soils, terrain, geomorphology, groundwater prospects and infrastructure are generated at 1:50, 000 scale using remote

sensing data and conventional surveys. These data are then integrated to generate 'action plans' for land and water management (NRSA, 1995, Nidumolu and Alanga, 2001, Harmsen and Nidumolu, 2002). The databases are intended for use by district-level planning officials in the area of agricultural development and water and soil conservation in the wider perspective of district rural development. The IMSD study areas have been identified by the respective State and District Administrations as relatively less developed areas, experiencing resource-related problems such as land degradation, topsoil loss and sub-optimal yields. The selection of such areas for the study is supported by the views expressed by Ruben et al., (2003), who argue that a substantial impact on poverty-alleviation and sustainable natural resource management might be expected from targeting investments in less-favoured areas (LFAs). The existing approach for generation of 'action plans' relies on generic prescriptions for entire study areas based on the resource potentials. We argue that land use analysis requirements vary for different areas and that stratification of a region for analysis will focus attention on specific requirements. For example, if in an area a dominant cropping system exists (for example rice), then the farmers could benefit from advice on improved management practices for higher yields, while in another area, characterized by a multitude of crops, the farmers would benefit from advice on crop selection. Alternatively, in areas where soil and water conservation to limit land degradation is an issue; policy initiatives could support farmers who move from agriculture to activities that demand less of the land such as agro-forestry. Therefore, identifying areas with different requirements as a precursor to a detailed land use analysis would make the analysis better targeted and more efficient.

In this paper, a method is described that uses the association between soils and broad land use classes to identify areas with specific agricultural land use objectives viz., Crop Management Improvement, Crop Selection and Conservation. In case of areas designated for Crop Management Improvement the focus is on optimising land use management without a change in the crops grown. The objectives of a Crop Management Improvement process include improving water and fertiliser use-efficiencies through identifying the factors that limit production and alleviating their impact through improved management. In Crop Selection areas suitable crop can be chosen based on land suitability, market demands and in rain-fed areas reducing risks of investments and production, while facing uncertain weather-specific yield-limiting conditions. Conservation is relevant in case of doubt about the suitability of the

land for cropping and raises the question of whether to crop the land at all. A mismatch between land quality and land use results in land degradation (Beinroth, 1994); this may be associated with strong negative impact of use on land quality and/or low productivity. In practice, large areas of such land are not cultivated or have been abandoned after cultivation.

The objectives of this study are to stratify an area as a pre-field exercise for a focused land use analysis. To attain those objectives we: (a) identify relationships between soils and associated land cover/use and identify patterns in these relationships (b) analyse the relationships observed on the basis of *a priori* knowledge of the area and the available statistics and (c) verify these relationships in the field and through interviews with farmers. The results are intended to support district land-use planners in focusing on specific objectives in detailed land use policy formulation.

3.2 Study area

The study area is on the Deccan Plateau in the western part of Nizamabad district of Andhra Pradesh State, India (Figure 3.1). The soils in the study area can be classified into four major orders – Inceptisols (67% by area), Alfisols (15%), Vertisols (10%) and Entisols (8%). Geomorphological features in the study area are of structural, denudational and fluvial origin. Nearly 69% of the land is in the 0-1% and 12% in the 1-3% slope category. The climate is tropical; average annual rainfall is 897 mm received in 57 days, of which about 95% is received during the southwest monsoon. There are hot summers (maximum mean monthly about 40 °C) and generally cool and dry winters (minimum mean monthly about 13 °C).

Administratively, the study area comprises the mandals¹ Kotgir, Birkur, Bichkunda, Madnur, Jukal and Pitlam, with a total area of about 1300 km². It comprises 220 villages and a population of 294,000 (Census of India, 2001). Historically, agriculture is the primary occupation of the local population with about 80% depending on it for its livelihood (Chief Planning Officer, 2001; District Gazetteer, 1973). Total agricultural land is about 90,000 hectares and non-cultivated areas with or without scrub is about 18,000 hectares. Annual *per capita* income of the farmers is about Indian rupees 33,000 (approx. US\$ 700). The literacy rate is about 25%. Large numbers of farmers have holding sizes

¹ A mandal is an administrative sub-division of a district.

ranging from 0.5 ha to 3 ha. Population in the area increased from 222,000 in 1991 to 294,000 in 2001, an increase of about 3.2% per year (Chief Planning Officer, 1991, 2001). Statistical data from the same source indicate a reduction of 20% in area of permanent pastures and an increase of 34% in agricultural area during the same period (Figure 3.2). These statistics indicate that land resources in the area are under pressure, largely because of population pressure. The Deccan Plateau of central India (of which the study area forms a part), consisting of fertile soils derived from basalt, where soil loss is expressed in meters rather than in millimetres, is a typical example of the worldwide problem of increasing pressure on land as a result of rising population (Hudson, 1987). This problem and its consequences for arable and pastoral production and environmental degradation have been discussed extensively and fundamentally by for instance Boserup (1965) and Mortimore (1995). Eswaran et al., (2001) in line with Boserup's (op cit) argument state that high population density does not necessarily lead to land degradation; it is what a population does to the land that determines the extent of degradation. Therefore, analysis of the *land* versus *use* could indicate of what the population does to the land.

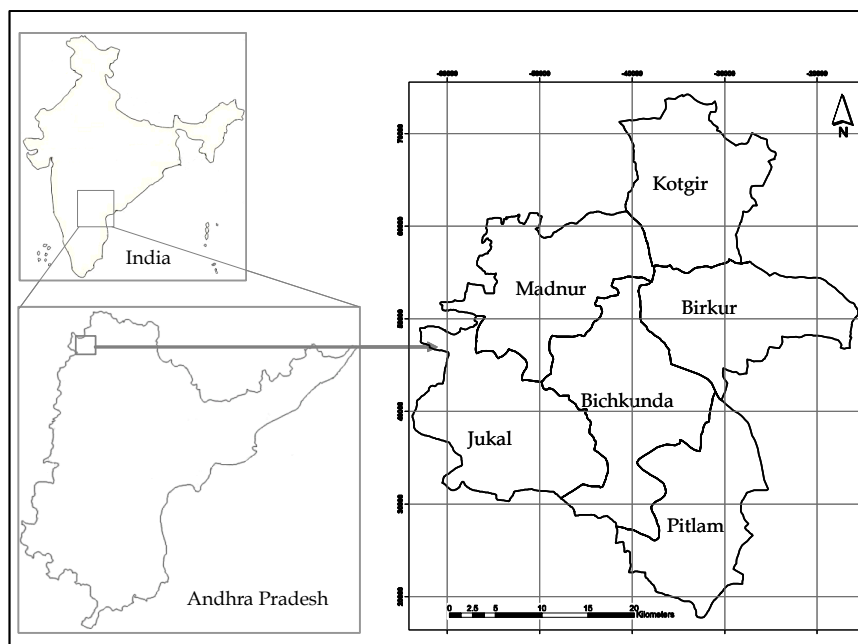

Figure 3.1. Location of the study area with mandal boundaries

There are two major agricultural seasons viz., Kharif (from June to October) and Rabi (November to March). About 33.8% of the study area is irrigated (including both the Kharif and Rabi seasons). Average rainfall in the Rabi season is only 158.7 mm, therefore Rabi crops are mostly grown where irrigation exists or in heavy black cotton soils that retain moisture from the monsoon. Crops such as jowar (*Sorghum bicolor* (L.) Moench) and bajra (*Pennisetum L. Rich.* (Poaceae)), with low water demands, are grown in these soils.

In heavy textured soils, sorghum is the principal crop, followed in rank order by cotton. While other crops include safflower (*Carthamus*), bengal gram (*Cicer arietinum*) and dry chillies (*Capsicum annuum*; *C. frutescens*) (Table 3.1). Under assured irrigation on heavy textured clay loam soils, rice and sugarcane are the principal crops. Rice is cultivated in both the Kharif and Rabi. On light textured soils (sandy loams and loamy sands), groundnut, sunflower, green gram (*Vigna radiata*) and vegetables are the principal crops (Rao, 1995).

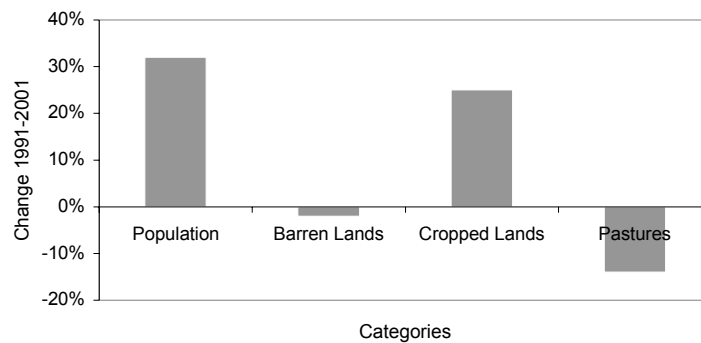

Figure 3.2. Change in population and land cover in the study area between 1991-2001 (Source: Chief Planning Officer, 2001)

3.3 Data

3.3.1 Map data

Land-use maps depicting spatial cropping patterns were generated from Indian remote sensing satellite data for both Kharif and Rabi of the same agricultural year. The maps were generated through visual interpretation techniques and the use of topographic maps, district records and field investigations. Soil maps at scale 1:50,000 were generated, up to series level, following the USDA soil

classification. Soils within a series are developed from the same parent material in the same environment and their profiles are almost alike with horizons that are similar in their properties (Dent and Young, 1981). The procedures adopted for generating the database have been discussed in detail in the IMSD Technical Guidelines (NRSA, 1995). GIS data have been generated according to the Indian National (Natural) Resources Information Systems (ISRO, 2000) standards.

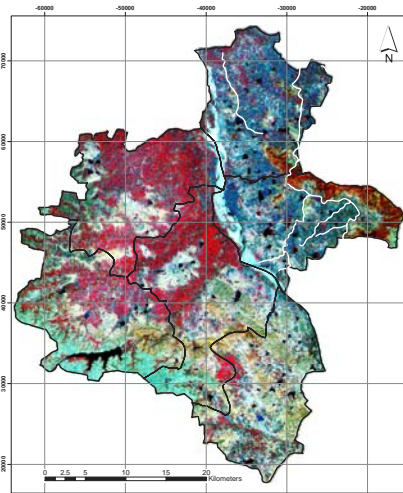

3.3A

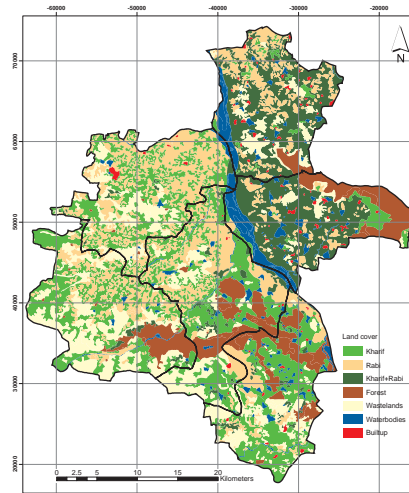

3.3B

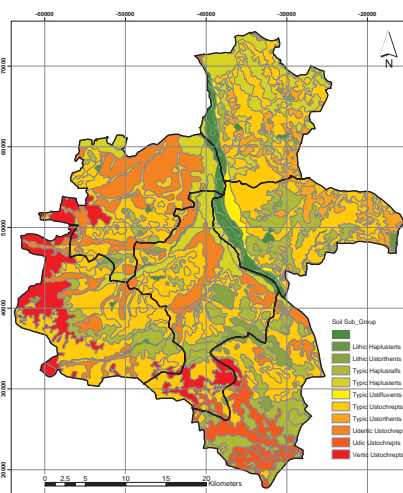

3.3C

Figure 3.3A: IRS Satellite imagery of January 18, 2001

Figure 3.3B: Land cover map depicting agricultural classes, Kharif, Rabi & Kharif + Rabi and other classes

Figure 3.3C: Soil Sub_Group map

3.3.2 Field data

Fieldwork consisting of field observations, interviews with farmers, and mandal and district line-department officials, was conducted in two phases during May-July and September-December 2002. Digitising/geo-referencing was made with a mobile GIS system; in the field, coordinates of the field interviews were recorded. Farmers' responses were defined as attribute data.

Table 3.1: Area devoted to major crops (percent of agricultural area) in the study area.

| | Rice | Jowar | Pulses | Sugarcane | Groundnut | Cotton | Others | Total |
|--|-------|-------|--------|-----------|-----------|--------|--------|-------|
| Kotgir | 42 | 9 | 9 | 16 | 2 | 10 | 12 | 100% |
| Birkur | 70 | 1 | 2 | 8 | 5 | 1 | 13 | 100% |
| Bichkunda | 17 | 20 | 23 | 4 | 2 | 18 | 16 | 100% |
| Madnur | 8 | 22 | 21 | 0 | 1 | 26 | 22 | 100% |
| Jukal | 2 | 28 | 28 | 0 | 0 | 23 | 19 | 100% |
| Pitlam | 37 | 16 | 21 | 6 | 8 | 5 | 7 | 100% |
| Total area in Ha (including Kharif and Rabi seasons) | 41290 | 18016 | 31073 | 4165 | 5494 | 6622 | 6861 | |

3.4 Method

The method is illustrated in Figure 3.4. Land-use data were combined with soil data using standard GIS operations. The relationship between soil series and the overlaying land use was inventoried using the query facility in ArcView[®], yielding data on areas of the major land use classes, Kharif-crops, Rabi-crops, (Kharif + Rabi)-crops, and non-cropped (divided into land with scrub and land without scrub) for each soil series. The soil order was used as the boundary condition for the inventory.

Following the inventory of the relationships between soil series and land use classes, a method was developed to categorise the relationship as the basis for theoretical interpretations. The method is based on interpreting: (i) percentage of cropped and non-cropped area occurring in each of the soil series and their spatial distribution; (ii) data on the spatial distribution of cropping pattern. The interpretation was to derive the land use objectives for the study area. It is formulated as described below:

[®] ArcView is a registered product of ESRI, Redlands, USA.

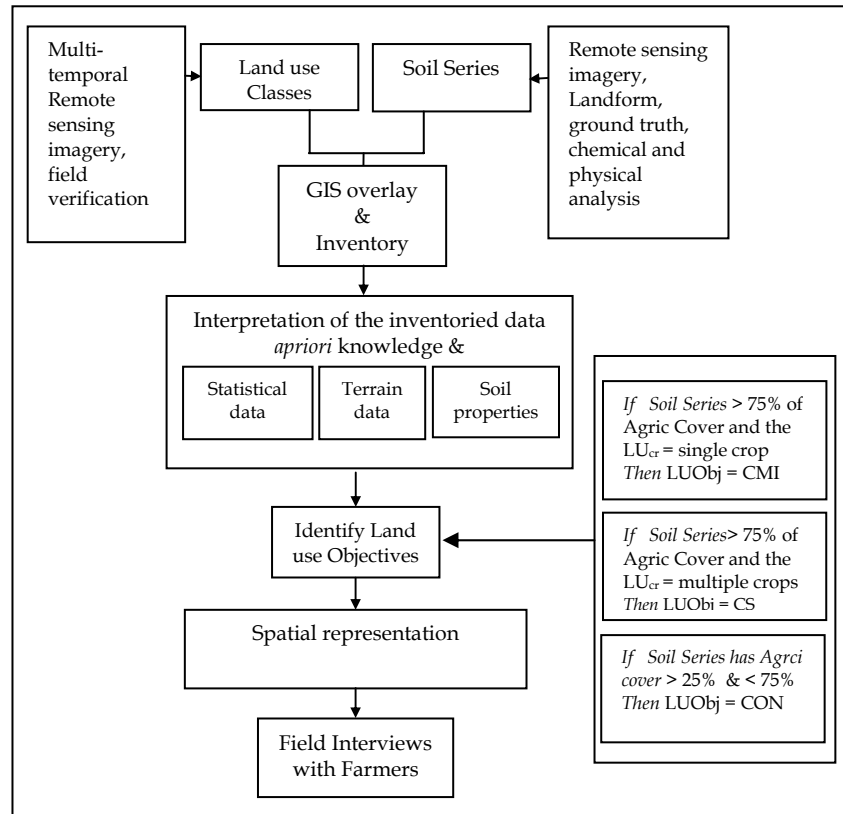

Figure 3.4. Schematic presentation of the analysis method (see text for explanation); $LUObj$ = Land Use Objective; CMI = Crop Management Improvement; CS = Crop Selection; CON = Conservation

- Let S_i be the area of soil series ($i = 1, 2, \dots, n$).
- Let LU_{cr} be the area of major land use class cropped land (Kharif only, Rabi only and Kharif and Rabi, split in predominantly cropped to a single crop and cropped to many crops).
- Let LU_{ncr} be area of major land use class non-cropped land (split in two cover classes, with and without scrubs).

3.4.1 Analysis

Based on the above discussion the land use analysis objectives are formulated:

If Soil Series S_1 is overlain by > 75% of LU_{cr} and predominantly a single crop, then the priority land use objective is 'Crop Management Improvement (CMI)'. If Soil Series S_1 is overlain by > 75% of LU_{cr} in the area and multiple crops of

cultivated, then the priority land use objective concerns “Crop Selection (CS)”. If the *Soil series* S_1 and LU_{cr} relationship is, $25\% < \text{Soils Series } S_1 > 75\%$, then the priority land use objective concerns “Conservation (CON)”, especially when the land has a poor cover (no scrubs). When Soil series S_1 overlain by $< 25\%$ LU_{cr} , then no priority regarding agricultural land use is set.

We propose that two groups of soil series, say A and B be distinguished: Group A, those Series that have agricultural area greater than 75% overlying them and Group B, series that have less than 75 % agricultural land overlying them. The t-test to test if the two groups are statistically different reveals a value of 1.60 at df 17 which is significant at 95% confidence level proving that the two groups are significantly different.

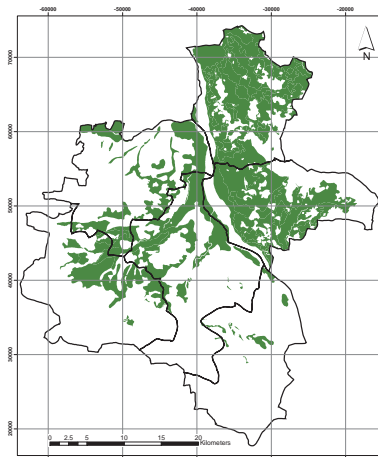

(i). Crop Management Improvement (CMI)

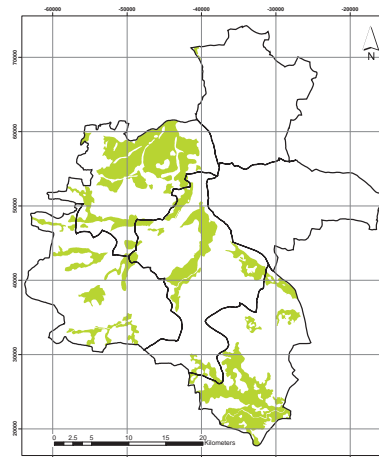

(ii). Crop-Selection

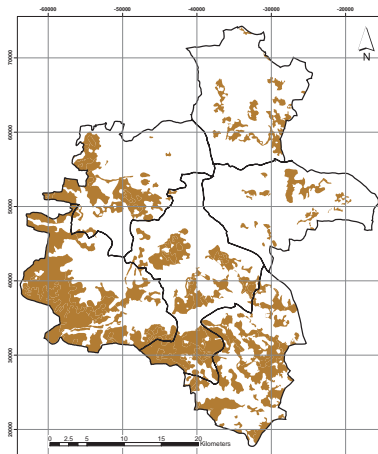

Figure 3.5A Areal spread of Land use Objectives.

(iii). Conservation



CMI : Rice fields in Kotgir Mandal



CON: Shrub land in Jukal Mandal



CS: Crop affected due to water shortage in Pitlam Mandal



CON: Shallow sandy soils in parts of Pitlam Mandal

Figure 3.5B. Field pictures of the CMI, CS and CON areas

If in a soil series the land use classes Kharif, Rabi and Kharif + Rabi occupy 75% or more of the area, the inference was made that the local farmers considered the land as 'suitable' for agriculture. If a soil-series/sub-group was distributed evenly among agricultural and non-agricultural land-use classes, this could be interpreted as either an indication of pressure on land (land less suitable for agriculture being used for agriculture) or of a limitation by (an)other constraint(s) (land suitable for agriculture, but not used). This interpretation forms the basis for the identification of broad land-use analysis objectives: Crop Management Improvement, Conservation, and Crop Selection. The results are spatially depicted in Figure 3.5A with field pictures in Figure 3.5B and graphically in Figure 3.6.

3.5 Validation of results

The results from the analysis were validated with reference to the following independent sources: (a) Statistical data obtained from the District Planning

Office; (b) Data on the physical and chemical properties of the soils obtained from the IMSD project (NRSA, 1995); (c) Terrain data in the form of a slope map; (d) Field visits and interviews with farmers.

a) Statistical data

Two sets of data available from the District Planning Office on extent of the irrigated area and the areal extent of crops, aggregated to mandal level, have been used. Areas covered by the three land use objectives have been calculated at mandal level for comparison with the crop statistics at mandal level. The comparison (Figures 3.7A & 3.7B) is between the percent area covered by each of the land use objectives in a mandal with: (a) percent area under irrigation in the mandal; and (b) percent area of a particular crop in the mandal. Percent areas have been used for ease of comparison. It can be seen from the Figure 3.7, that Kotgir and Birkur mandals (where the *Bodhan*, *Anksapuram*, *Birkur* and *Uppalvai* series occur) have significant areas covered by Crop Management Improvement (85 and 87% of the mandal agricultural area, respectively). The irrigated area in these mandals is 43 and 57%, respectively. Rice cultivation in these mandals covers respectively 42 and 70% of the agricultural area. Sugarcane is the next dominant crop with 16 and 7 %. These data support the analysis which concluded that in areas characterized by a single dominant crop the main objective could focus on the improvement crop management for higher yields.

Alternatively, in Jukal mandal a higher percentage of the area is diagnosed for Crop Selection. The mandal has a very small area under irrigation (2.5% of the agricultural area) and there is no single dominant crop. Similar situations are found in other mandals, like Pitlam, which is characterized by a significant area identified for Crop Selection. Here, in contrast to the areas identified for Crop Management Improvement (with predominantly rice cultivation), farmers grow a wide variety of crops. This conclusion is supported by the data in Figure 3.7, which shows that crops such as jowar, pulses, sugarcane, groundnuts, cotton and others cover an average 78% of the agricultural area. These statistical data support the interpretation that Crop Selection areas are characterized by multiple cropping systems with restricted irrigation facilities. Farmers here might benefit from advice from the extension service on suitable crop selection. Note further that mandals with higher percentages of Crop Management Improvement areas are characterized by highly demanding crops, such as rice and sugarcane, while mandals with higher percentages of Crop Selection and

Conservation areas are characterized by less-demanding crops, such as jowar and pulses. Correlations at mandal level between Crop Management Improvement, Crop Selection and Conservation areas and irrigated areas and crop types are shown in Figure 3.8.

(b) Comparing areas identified for Crop Management Improvement, Crop Selection and Conservation with slope data

Areas identified for Crop Management Improvement and Crop Selection occur significantly (52 and 27%) in slope category 0-1%. This observation is in agreement with the idea that Crop Management Improvement- and Crop Selection-areas (basically identified for agriculture) occur in flat land, while Conservation areas occur in relatively more sloping land. A typical example of the sloping land is the *Chapta* series, which shows visible signs of degradation, both on the remote sensing image and in our field investigations.

(c) Comparison with soil properties

Figure 3.9 shows that within the areas identified for Conservation by far the greatest area is characterized by very sandy soils (sand 80-88%), whereas areas identified for Crop Management Improvement and Crop Selection have less sand and deeper topsoils. Areas identified for Crop Selection are positively correlated with clay content. An example is Madnur mandal where 48% of the agricultural area is identified for Crop Selection, and 76% of the area has clay contents of 38-49.6%. These are basically areas of black cotton soils, exhibiting workability problems during the Kharif season. The farmers use these soils for agriculture during the post-monsoon period when they depend on residual soil moisture. They have limited supplementary irrigation. A variety of crops are grown, viz., rice (7.5%), jowar (22.4%), pulses (20.5%), sugarcane (0.1%), groundnut (1.0), cotton (26.4%) and other crops (22%). These characteristics support the conclusion that farmers in such areas (identified as Crop Selection) might benefit from advice on suitable crop selection.

A: Crop Management Improvement

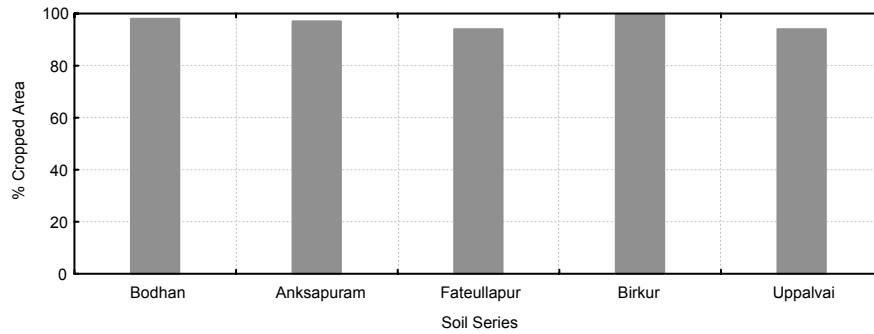

B: Crop Selection

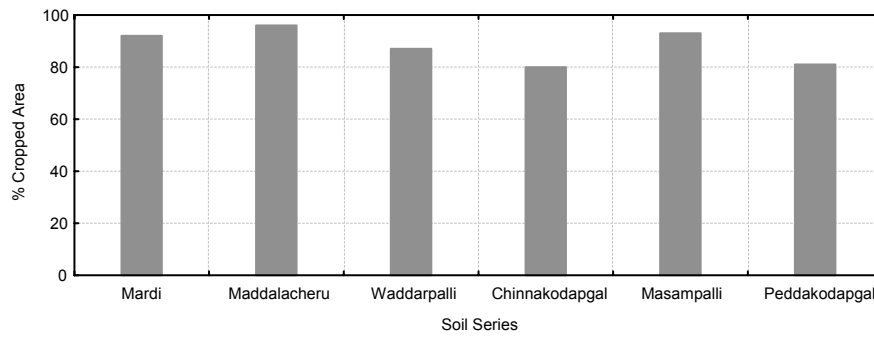

C: Conservation

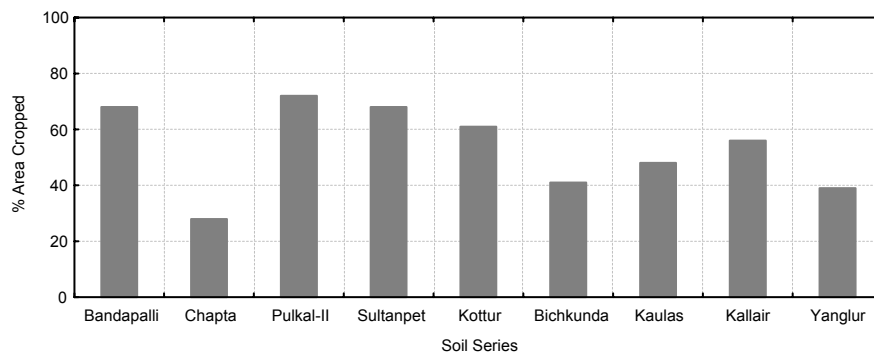
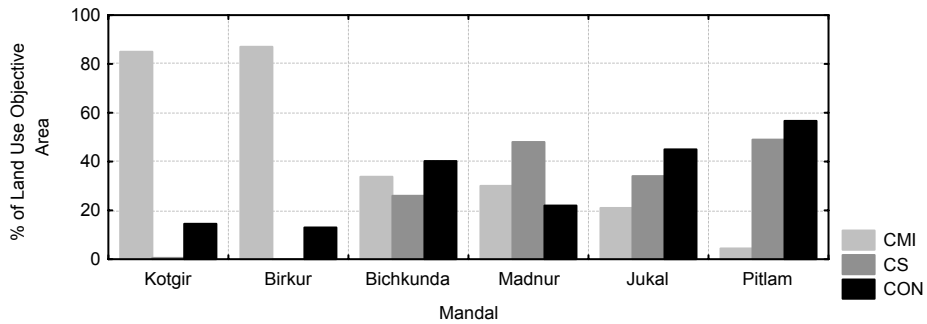
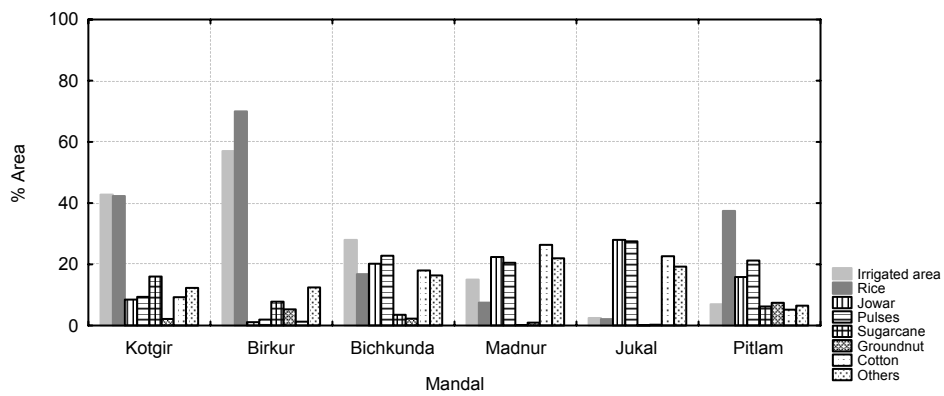

Figure 3.6. Area of current land uses for different soil series for three Land Use Objectives in the study area.



3.7A



3.7B

Figure 3.7A. Extent of land use objectives (per cent of total area) 3.7B. Area (ha) devoted to major crops (per cent area in the study area. CMI = Crop Management Improvement; CS = Crop Selection; CON = Conservation

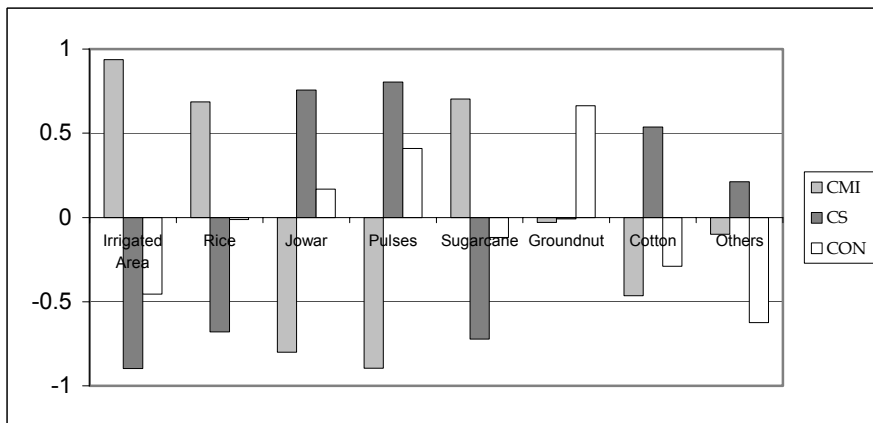
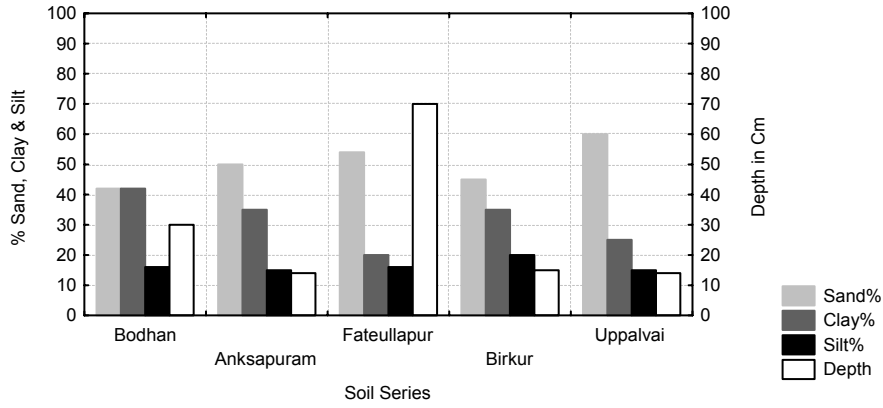
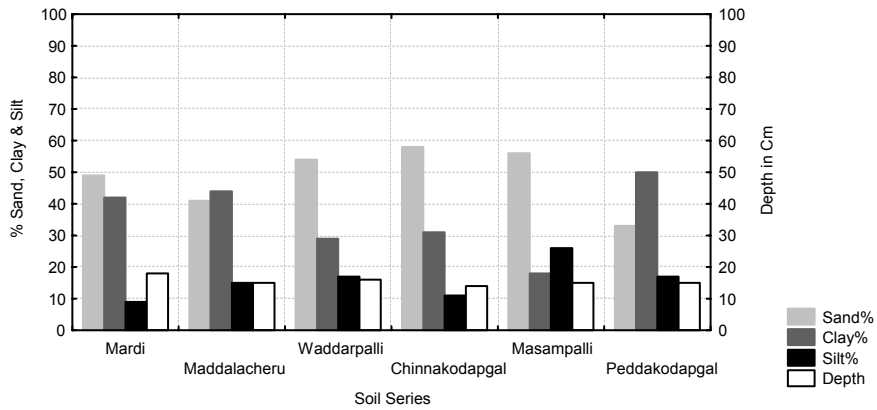

Figure 3.8. Correlations at mandal level between CMI, CS and CON areas and irrigated areas and crop types. CMI: Crop Management Improvement; CS: Crop Selection; CON: Conservation

A. Crop Management Improvement



B. Crop Selection



C. Conservation

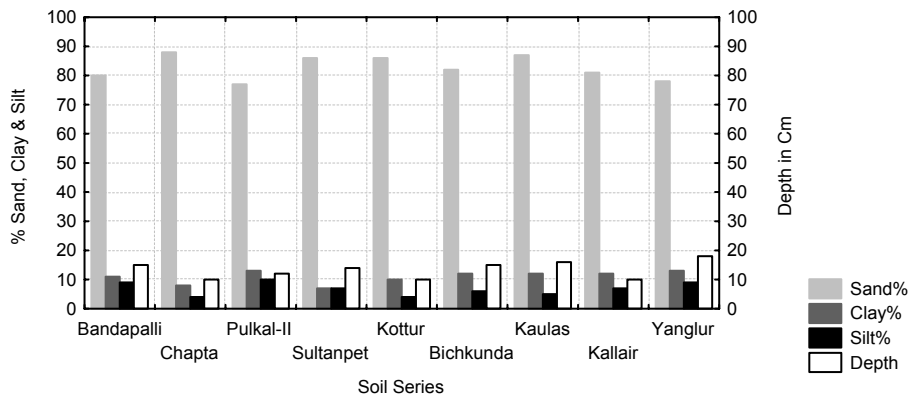

Figure 3.9. Soil texture and depth of soil series in relation to the Land use Objectives.

Table 3.2: Farmer interview locations with overview of their response

| No | Village/ Mandal | Land use Objective identified in the analysis | Cropping pattern as described by farmers | Overview of farmers' responses |
|----|---------------------------|---|---|--|
| 1 | Ethonda/Kotgir | CMI | Rice-Sugarcane Rice-Rice | Low yields due to lack of adequate water supply. Application of more fertilizer than recommended. Rice-Rice mono cropping |
| | | CON | Rice-Jowar | Subsistence farmer, no alternative |
| 2 | Chikatpalle/Kotgir | CON | Rice | Since water is available prefers rice like his ancestors |
| | | CS | Rice | Low yields due lack of adequate water supply. Inadequate extension service. Land tenure issue |
| 3 | Rampur/Kotgir | CON | Rice-Turmeric | Application of sufficient quantities of fertilizers may improve land quality |
| | | CMI | Rice | Extension service suggestions for improved yields are expensive to implement |
| 4 | Kodcherla/Kotgir | CMI /CS | Rice-Sugarcane-Sunflower | Crop rotation practiced to reduce pest risks, use of organic fertilizers |
| 5 | Sangam/Birkur | CMI | Rice | Yields decline with time, suggestions on management improvements needed from extension service |
| 6 | Bommandevpalle/ Birkur | CMI | Rice | Irrational use of fertilizer and pesticide. |
| 7 | Mylaram/Birkur | CON | Rice-Jowar-Sunflower | Subsistence farmer |
| 8 | Keroor/Madnur | CS | Cotton- Groundnut-Rice- Jowar-Bajra | Water is a constraint, small scale farmer, extension advice needed |
| 9 | Mainur/Madnur | CON | Rice-Cotton | Subsistence farmer |
| 10 | Dongli/Madnur | CMI/CS | Cotton-Pulses-Sunflower | Power problem to run pump sets for water supply, pest problem in cotton |
| 11 | Limboor/Madnur | CS | Cotton-Pulses | Flooding risk during monsoon, pest problem in cotton |
| 12 | Pulkal/Bichkunda | CS | Cotton-Tobacco-Pulses-Jowar-Chilli | Lack of extension service advice |
| 13 | Rajola/Bichkunda | CS | Rice-Sugarcane-Jowar-Maize | Water constraint |
| 14 | Padampalle/Jukal | CON | Rice | When water is available, the farmer will opt for rice even though he is aware that his land is not suitable for rice cultivation |
| 15 | Siddapur/Jukal | CON | Groundnut-Sunflower-Cotton | Shallow soils, no adequate irrigation, subsistence farmer |
| 16 | Siddapur/Pitlam | CS | Rice-Vegetables-Sugarcane | Water constraint, subsistence farmer |
| 17 | Potheredipalle/ Pitlam | CON | Groundnut-Rice-Vegetables | Sandy soils, low water retention, subsistence farmer |
| 18 | Nagampalle / Pitlam | CMI | Rice | Land is suitable for rice cultivation but water supply is limiting, electric power limitation to run pump sets |

CMI: Crop Management Improvement; CS: Crop Selection; CON: Conservation

(d) Field visits and overview of farmers' responses

The field visits and interviews with farmers were conducted in eighteen villages across the six mandals of the study area. The procedure consisted of identifying the Crop Management Improvement, Crop Selection and Conservation areas with the aid of a mobile GIS/GPS system and interviewing farmers in the field. The questions related to farmers views on their soils, such as suitability of their soils for certain crops, access to extension service, water availability. The location of villages, land use objectives identified through the analysis and an overview of the farmers' responses are given in the Table 3.2. Based on our interviews with farmers, the purpose of which was to identify driving forces behind farmers' decisions on land use, and field observations, we conclude that some of the reasons for either degradation or sub-optimal use of land are: (i) presence of subsistence farmers; (ii) insufficient water for irrigation; (iii) lack of or inadequate extension support; (iv) lack of funds to implement suggestions from the extension service; or (v) specific dietary preferences for rice.

3.6 Conclusions

This study shows that different land use analysis objectives exist for different parts of the study area. The relationship between land (soil as an important land parameter) and land use can be used to differentiate such areas, which can be spatially depicted with GIS techniques. The results can be used to focus the efforts (when existing planning procedures are operational in an area) of planning and extension services as follows: (a) Crop Management Improvement (CMI) areas are those that could benefit from improved management practices for higher yields. A detailed study of the management practices of farmers can help in identifying inadequacies in their current management and suggest appropriate improvements. Methods, such as the Comparative Performance Analysis, which aim at defining major yield constraints and quantified yield-gap functions, could be applied; in the present study this refers to rice cultivation. (b) Crop Selection (CS) areas are those that require farmers to be advised on suitable crop selection based on the constraints they face. Methods such as multiple goal optimisation techniques could be applied to generate cropping options, considering factors such as socio-economic conditions of the farmers, market opportunities and policy instruments and (c) Conservation areas present the most critical challenge to the resource managers. Questions as to why marginal lands are cultivated and why in some cases sub-optimal land

use occurs have to be answered. The areas need specific alternatives in terms of a balance between land degradation and livelihoods of subsistence farmers. The resource managers need to identify alternatives to intense farming to prevent further degradation, while providing adequate livelihoods to local farmers. Advising farmers on alternatives for off-farm activities, silvo-pastoral activities, agro-forestry, agro-horticulture and associated activities in combination with measures for soil and water conservation might be considered in the framework of integrated rural development schemes operational in the area. Although the method we have developed focused on the identification of land use objectives, identification of the driving forces underlying farmers' decisions on land use will be useful in understanding the dynamics of land use in the study area.

The next chapter focuses on the analysis of areas identified for Crop Management Improvement (CMI). Two mandals viz., Kotgir and Brikur (with predominant CMI areas) have been selected to conduct the study. Paddy rice which is the dominant crop has been chosen as an example to demonstrate the Comparative Performance Analysis and identify yield constraints.

References

- Beinroth, F.H., Eswaran, H., Reich, P.F., Van Den Berg, E., 1994. Land related stresses in agro-ecosystems. In: *Stressed Ecosystems and Sustainable Agriculture*. Virmani, S.M., Katyal, J.C., Eswaran, H., Abrol, I.P., (Eds), Oxford and IBH: New Delhi.
- Boserup, E., 1965. *The conditions of agricultural growth. The Economies of Agrarian Change under Population Pressure*. George Allen and Unwin: London.
- Census of India., 2001. *Andhra Pradesh, Provisional Population Totals. Paper 3 of 2001*, Director of Census Operations. Hyderabad, India.
- Chief Planning Officer., 1991 & 2001. *Handbook of Statistics- Nizamabad District*, Chief Planning Officer, Nizamabad, Andhra Pradesh.
- Cools, N., De Pauw, E., Deckers, J., 2003. Towards an integration of conventional land evaluation methods and farmers' soil suitability assessment: A Case study of North-western Syria. *Agriculture, Ecosystems and Environment* 95, 327-342.
- Daba, S., 2003. An Investigation of the physical and socio-economic determinants of soil erosion in the Hararghe Highlands, eastern Ethiopia. *Land Degradation and Development* 14, 69-81.

- De Bie, C.A.J.M., 2000. Comparative Performance Analysis of Agro-ecosystems. Ph.D. thesis. Wageningen University. Wageningen. 232 pp.
- Dent, D., Young, A., 1981. Soil Survey and Land Evaluation. George Allen and Unwin: London.
- Di Gregorio, A., Jansen, L., 1998. Land Cover Classification System (LCCS): Classification Concepts and User Manual. AGLS, SDRN: Nairobi/Rome.
- District Gazetteer., 1973. Andhra Pradesh District Gazetteers, Nizamabad District. Published by the Government Publication Bureau, Andhra Pradesh, Hyderabad.
- Eswaran, H., Lal, R., Reich, P.F., 2001. Land degradation: an overview. In: Bridges, E.M., I.D. Hannam, L.R. Oldeman, F.W.T. Penning de Vries, S.J. Scherr and S. Sompatpanit (Eds.). Responses to Land Degradation. Proc. 2nd International Conference on Land Degradation and Desertification, Khon Kaen, Thailand. Oxford Press, New Delhi, India.
- FAO., 1976. A Framework for Land Evaluation. Soils Bulletin 32. FAO. Rome.
- Hare, F., 1985. Climate, Variation, Drought and Desertification. World Meteorological Organisation: Geneva.
- Harmsen, K., Nidumolu, U.B., 2002. Land use Planning for Sustainable Development in South Asia: An example from India. In: Navalgund, R.R., Nayak, S.R., Sudarshana, R., Ravindran, S. (Eds), Resource and Environmental Monitoring. ISPRS & SIS, 34, 7, 1467-1475. Hyderabad, India.
- Hudson, N.W., 1987. Limiting Degradation Caused by Soil Erosion. In: Wolman, M.G., Fournier, F.G.A. (Eds), Land Transformation in Agriculture. John Wiley and Sons Ltd, Chichester.
- ISRO., 2000. National Natural Resources Information System (NRIS) Node Design and Standards: NNRMS, Indian Space Research Organisation (ISRO), Bangalore.
- Messing, I., Fagerström, M.H.H., 2001. Using farmers' knowledge for defining criteria for land qualities in biophysical land evaluation. Land Degradation and Development 12, 541-553.
- Mortimore, M., 1995. Caring for soils. Agricultural expansion, population growth and natural resource degradation in the Sahel. In: Reenberg, R., Secher Marcussen, H. (Eds). Ethnobotany, Agricultural and Pastoral Strategies and Development Aid Strategies, Proceedings of the 7th Danish Sahel Workshop, 4-6 January, Occasional Paper No. 1, SEREIN: 55-57.
- Nidumolu, U.B., Alanga, P., 2001. Natural Resources Information Generation for planning: An Indian Example. GIM International 15, 6.

- Nielsen, T.L., Zobisch, M.A., 2001. Multi-Factorial causes of Land-use change: Land use dynamics in the agropastoral village of Im Mial, Northwestern Syria. *Land Degradation and Development* 12, 143-161.
- NRSA., 1995. *IMSD Technical Guidelines*. National Remote Sensing Agency. Hyderabad, India.
- Rao, S.V.C.K., 1995. Cropping pattern analysis using temporal IRS-LISS II data- A case study of Madnur watershed, Nizamabad district, AP. Indian Institute of Remote Sensing, Dehradun.
- Ravnborg, H.M., Rubiano, J.E., 2001. Farmers' decision making on land use - The importance of soil conditions in the case of Rio Cabuyal watershed, Colombia. *Geografisk Tidsskrift* 101, 115-130.
- Roe, E., Huntsinger, L., Labnow, K., 1998. High reliability pastoralism. *Journal of Arid Environments* 39, 39-55.
- Rossiter, D.G., van Wambeke, A.R., 1993. *Automated Land Evaluation System*. Cornell University. Department of Soil, Crop and Atmospheric Sciences. New York, Ithaca.
- Ruben, R., Kuyvenhoven, A., Hazell, P., 2003. Investing in poor people in less-favoured areas: Institutions, technologies and policies for poverty alleviation and sustainable resource use. In: *International Conference on Staying poor: Chronic Poverty and Development Policy*, IDPM Manchester, 7-9 April, 2003.
- Talwar, S., 1996. *Local Soil Classification and Management Practices: Bibliographic Review*. Research paper 2. Laboratory of Agriculture and Natural Resource Anthropology. Department of Anthropology, Athens, University of Georgia.
- Talwar, S., Rhoades, R.E., 1998. Scientific and Local Classification and Management of Soils. *Agriculture and Human Values* 15, 3-14.

Chapter 4

Identifying Options to Improve Irrigated Rice Cropping Systems through Comparative Performance Analysis

Abstract

Crop management improvement studies explore existing land use systems to identify and quantify, amongst others, suffered yield gaps and to suggest management improvements. This study focused on identifying yield determinants of irrigated rice (*Oryza sativa*), grown during the post-monsoon (Rabi) cropping season in Nizamabad District, Andhra Pradesh, India. The impacts on yields of management factors and of site-specific land characteristics were studied in the irrigated parts of the district for the 2001-2002 season. Reported Yields by farmers varied from 2595 kg/ha to 8649 kg/ha with a mean of 6521 kg/ha and standard deviation of 1284 kg/ha. Yield constraints were identified through a comparative performance analysis using data collected through interviews with farmers. The stepwise multiple regression model produced a yield model with 5 land and management parameters which explained 55.7% variability of yields. The overall yield gap was estimated to be 2099 kg/ha by using calculated 'average' with calculated 'best' situation. The main yield constraints were water shortage (27%), number of fertiliser applications (22%), date of harvesting (21%), second weeding (19%) and ground water yield (11%). Water shortage was a function of availability and accessibility. Most of the tube wells in the area are power driven and frequent shortages of power limited access. Lower groundwater yields affected availability. The farmers in the area do not seem to follow a standard fertiliser regime and hence the effect of fertiliser on yields could not be clearly established except for the number of applications. Disease and pests do not seem to be a major constraint in Rabi rice in the study area. The result shows that the extension service is required to concentrate on water and nutrient management, weeding, date of transplanting and harvesting.

Key Words: Crop Management Improvement; rice yield gap; multiple stepwise linear regression; Remote Sensing; GIS; Comparative Performance Analysis

Based on: Uday Bhaskar Nidumolu, Kees de Bie and Herman van Keulen. Identifying Options to Improve Irrigated Rice Cropping Systems through Comparative Performance Analysis. (*In Review: European Journal of Agronomy*)

4.1 Introduction

In the Indian context, concerns are being expressed whether rice production increases can keep pace with the demand of the increasing population. As most of the area currently is double or triple cropped, intensification is not an option, so that yield increases are necessary to cope with the growing demand (RWC, 2003). The demand for rice in India is projected at 128 million tonnes for the year 2012, equivalent to a production level of 3000 kg/ha, significantly exceeding the present average of 1930 kg/ha (Tiwari, 2002). Reducing this yield gap increases production. The first step in narrowing the yield gap is to identify actual and potential production constraints that may vary among regions (Duwayri et al., 2000). Yield gap for rice varies from about 15 to 60% and yield constraints for rice include: floods and droughts, soil acidity/alkalinity, water shortage, nutrient shortage and incidence of pests and diseases, subsistence farming, ineffective transfer of technology (Siddiq, 2000). All these factors fuel the fears of agricultural scientists, policy makers and economists that it may not be possible to increase food production by 2.5% each year, the rate required to meet the demands of the growing population (RWC, 2003). However, rice production problems vary by region in India. Specific land management factors contributing to yield variability and yield gap at field level have to be identified to minimise yield gaps at regional scale.

Several studies have been reported on various aspects of rice yield gaps. Poussin et al., (2003) report on the effect of soil, weather variability and crop management on rice yield formation in the Senegal River valley. Applying principal component analysis, they conclude that most of the yield variability is due to differences in crop management at field level. Singh et al., (2002) in their study on rice-wheat systems in Bihar, India, conclude that the critical yield determinants include delayed seedling raising and transplanting of rice, and late sowing of wheat due to late availability of canal water and its heterogeneous distribution, inadequate number of shallow tube-wells, ineffective use of rain-water, and lack of conjunctive use of different irrigation water sources. Asch and Wopereis (2001) document yield variability in rice due to varying levels of floodwater salinity in a semi-arid environment of the Senegal River delta. Casanova et al., (1999) identified and quantified field-level soil properties limiting rice growth under fully irrigated, direct seeded conditions in the Ebro Delta, Spain. Becker and Johnson (1999) compared rice yields in farmers' fields and researcher-managed sub-plots in irrigated systems in West Africa, focusing on three variables viz., water control, weeds and

nitrogen, applying a General Linear Model. Yield losses, analyzed through multiple regression, were attributed to management practices of the farmers. Savary et al., (1997) analysed yield losses in rice due to diseases, insects and weeds in the rice-wheat system of India, using principal component analysis and step-wise multiple regressions. Dingkuhn et al., (1995) discuss climatic determinants of irrigated rice performance in the Sahel.

In this paper, we apply Comparative Performance Analysis (CPA) to a case study in Nizamabad district of Andhra Pradesh state in India to model crop management improvement as a component of a regional agricultural land use planning programme. First, we briefly describe the significance of rice in the study area. Theoretical concepts behind CPA are discussed subsequently. Then, we discuss descriptive statistics of the field data about the variables used in the study viz., soils, varieties, land preparation, transplanting, fertiliser application, weeding, pest control, water management, actual and expected rice yields and farmer's perceptions of the reasons causing yield differences. We use multiple stepwise-regression for analysing data and development of the model. Finally, we describe the results, provide discussions and draw conclusions.

4.2 Study Objective

The objective of the study is to identify the biophysical factors limiting the farmers' in the study area from realising the potential of their lands. The focus of the case study is on yield gap of rice. The study is a part of the crop management improvement objective identified in the area and in the larger context of contributing to the improvements in existing land use planning project for the study area.

4.3 Study Area

The study area is located in the south-western part of Nizamabad District in Andhra Pradesh state, India, comprising Kotgir and Birkur mandals² and a total of 70 villages (Figure 4.1). It measures 404 km², of which 223 km² is cultivated (Chief Planning Officer, 2001) and has a population of about 1, 00,000 (Census of India, 2001).

² A mandal is an administrative sub-division of a district.

The area consists predominantly of weathered pediplains and some flood plain areas along Manjira River. The dominant soils are red (inceptisols) and black (vertisols). Their characteristics range from moderately deep to very deep, calcareous to non-calcareous, fine to heavy textured, generally poorly drained (Rao, 1995) (Figure 4.2).

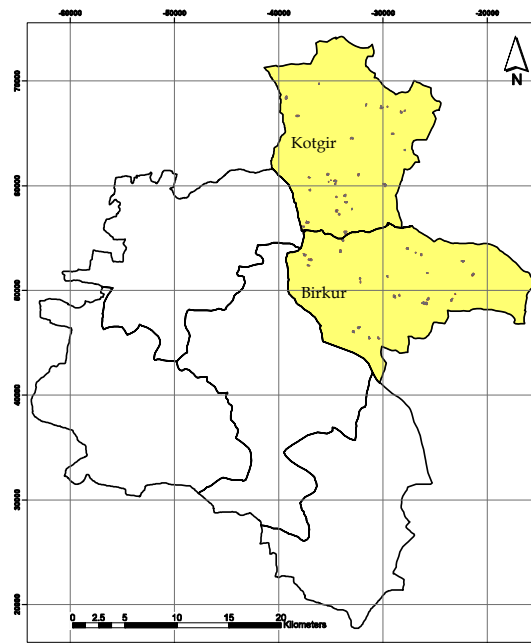

Figure 4.1. Location of the study area with Mandal boundaries and sample locations.

Two distinct agricultural seasons can be distinguished: (a) the wet season, locally called Kharif, extending from June till October with an average rainfall of about 870 mm, (b) the dry season, Rabi, extends from November till March with an average rainfall of 158 mm. Minimum mean monthly temperature is 13.3 °C in December and maximum 40 °C in May (Figure 4.3). The area is partly irrigated by water from Manjira River, canals, tanks and tube wells. Tube wells, equipped with electrical pumps are the main source of irrigation water in the post-monsoon cropping season serving 60% of the gross irrigated area. Canals serve 21% of the area. Major crops include rice, jowar (*Sorghum bicolor* (L.) Moench), sugarcane, groundnut and pulses. Rabi rice was planted on 7,947 hectares in the agricultural season 2000-01, representing about 64% of the area cultivated to major crops (Chief Planning Officer, 2001). About 70% of the holdings in the area are small holdings of less than 1 ha, accounting for 31% of

the cultivated area. Land holdings of 1-5 ha account for 50% of the cultivated area.

4.4 Study Method

4.4.1 Comparative Performance Analysis (CPA)

Comparative Performance Analysis (CPA) is a quantitative method for yield gap analysis (Herdt, 1982; de Bie, 2004). It aims at identifying major yield constraints and at defining quantified yield-gap functions. CPA compares production situations at actual on-farm sites. It assumes that land users operate at various technological levels, i.e. from conservative (traditional) to advanced (experimental), and applies management packages consisting of indigenous and improved technologies. For successful CPA, the study must focus on a particular land use class, in the present case, pertaining to irrigated rice cultivation in Rabi season and the survey must reflect the entire range of prevailing environmental conditions and all types and levels of technologies practised. CPA considers environmental conditions and management aspects as they occur in a specific study area (de Bie, 2000). CPA applies two basic functions:

- a. for quantifying yield (production) constraints:
Production = f (land, land use)
- b. for quantifying environmental impacts by the land use systems:
Impact = f (land, land use)

4.4.2 Field data collection

Fieldwork was carried out for five weeks during September-October 2002. Data were collected through field observations and site interviews with farmers, agricultural officers, extension services and research stations. Sampling was neither random nor representative for the study area as a whole, but included all levels of technology and different production levels achieved, to maximise the chance to identify major yield constraints. In the two mandals, 28 villages were randomly selected. 55 farmers were interviewed who cultivated rice during the Rabi season of 2001-2002 and were available and their rice fields sampled.

A hand-held computer, linked to a GPS was used to spatially mark the field samples on the Indian remote sensing satellite image (LISS III sensor) of March

2002 (Rabi season data relevant to the study) at a spatial resolution of six meters (Figure 4.4). Field data were normalised for statistical analysis and visualisation. Weighting factors were attached to each interview in the field (on a scale of 1-10), based on the researcher's perception of the quality of interview.

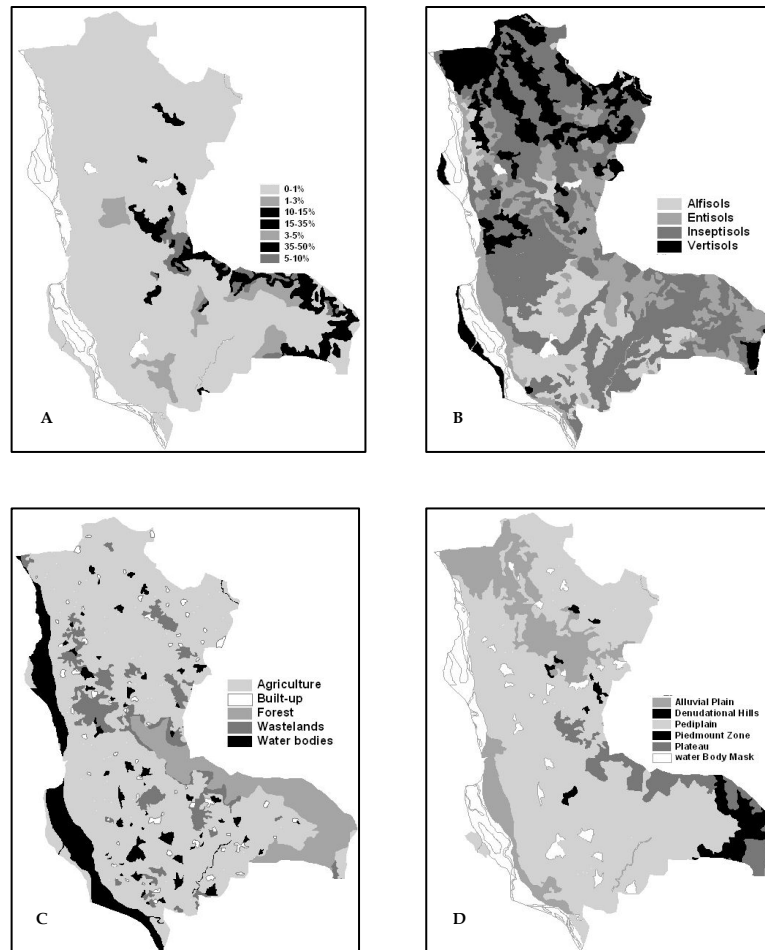

Figure 4.2. Natural resources setting of the study area A. Slope, B. Soils Order, C. Land cover, D. Geomorphology

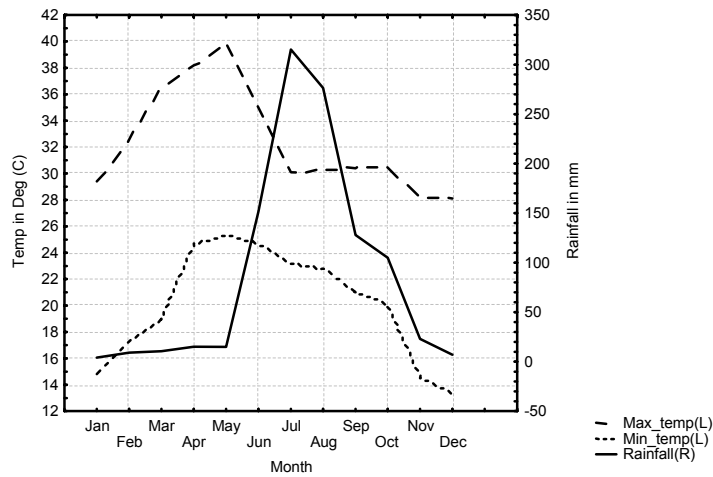

Figure 4.3. Average temperature and rainfall of Nizamabad District (Chief Planning Officer, 2001)

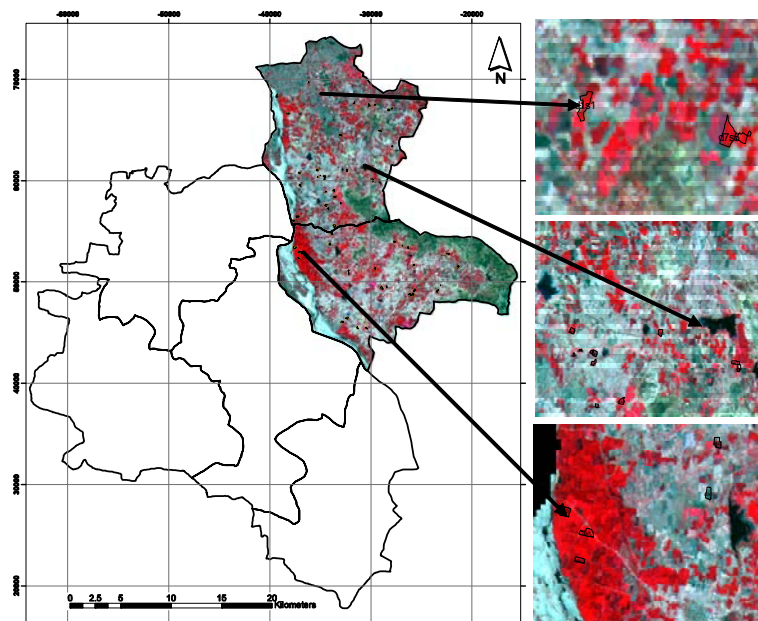

Figure 4.4: Sample fields digitised on the satellite image of March 2002

4.5 Descriptive statistics

All data were subjected to descriptive statistics. The crop management improvement objective was formulated as a model identifying the contributions

of individual yield constraints to the yield gap, using step-wise forward regression.

As a first step, the yield data (the dependent variable) were tested for normality. The normality condition has to be met to allow application of the regression analysis (Frank and Althoen, 1995). The yields from the survey data ranged from 2595 to 8649 kg/ha with a mean of 6521 and standard deviation of 1284 kg/ha. Figure 4.5 shows the distribution of yield fitted with a normal curve. Data normality was confirmed with the Shapiro-Wilk Test (*W Statistic* 0.95) and with a normal probability plot (Figure 4.6). The variables considered in explaining yield variation were grouped in the following categories: soils, rice variety, land preparation, sowing date, seed rate, date of transplanting, basal fertiliser application (date and rate), fertiliser top dressing (numbers, dates and rates), depth of water in the fields at the time of fertiliser application, weeding, incidence of pests and diseases, water shortage, date of harvesting, groundwater (depth and rate of flow in the pumps). All dates (number of days) are referenced to January 1, 2002.

4.5.1 Soils

Land factors, especially soil quality play a major role in crop yield, as it co-determines water and nutrient supply to crops. Natural properties of soils are important in the study area, as the farmers' economic situation does not permit large-scale physical or chemical modification of the soils for improved yield. The soil types were defined from the soil map of the area and field survey. Yield variation is smaller in Black_sandy soils than in Sandy soils, Black soils or Sandy_loam soils. Regression shows a significant impact of Black_sandy soil on yield, explaining 12.8% ($AdjR^2$) with a p value of 0.003. Black soil, which is the dominant soil type (34 out of the 55 samples), is used as the reference in the equation, for the effect of soil type on yield:

$$Y = a - b \text{ (If Black_sandy)} \pm c \text{ (If Sandy or Black or Sandy_loam)}$$

where, a (constant) is true for Black_sandy soil, Y is Yield, b and c are coefficients.

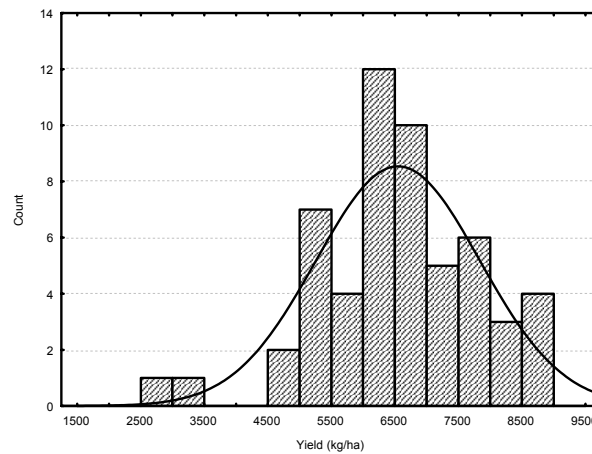

Figure 4.5. Distribution of yield fitted with a normal curve.

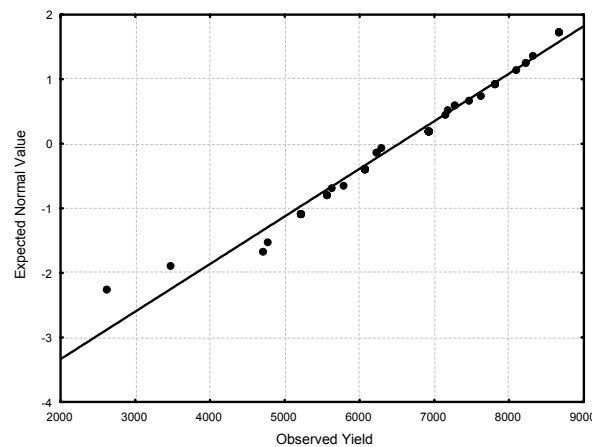

Figure 4.6. Normal Probability Plot of Yield

4.5.2 Rice variety

Improved rice (*Oryza sativa*) varieties, viz., BPT 5024, IR64, M7, MTU 1010, Tella Hamsa (TH), Erramalleu (Era) and Jagityal (Jgl) are grown in the area. The most common variety in the sample was MTU 1010 (37x), followed by TH (6x), BPT (5x), Era (3x), M7 (2x), Jgl and IR64 (1x each.) Only MTU, TH and BPT were considered in the analysis. ANOVA indicated no significant yield difference among varieties, compared ($p = 0.70$) to the dominant MTU (37 of 55) using the equation:

$$Y = a \pm b \text{ (If BPT)} \pm c \text{ (If TH)}$$

where, a (constant) is true for MTU, Y is Yield, b and c are coefficients.

4.5.3 Land preparation (ploughing and puddling)

Number of ploughings, either once (8x), twice (42x) or three times (5x) had no significant effect on yield (Adj R²= .009), nor did the number of puddlings, once (22x), twice (24x) or three times (9x), ($p = 0.13$). Tractor was the dominant implement for ploughing and puddling (52 and 53x, respectively). Hence, no comparison could be made between tractor and animal-drawn equipment for ploughing or puddling.

4.5.4 Seed Rate

Seed rate did not show a significant effect on yield with an Adj R² = -.01472056.

4.5.5 Transplanting days (with reference to January 1, 2002)

Traditionally in the area, rice is transplanted by hand, usually about thirty days after sowing, in tune with the recommendations (Brouwer et al., 1989), but the actual timing depended on labour availability. Regression analysis showed AdjR² = 0.066; $p = 0.03$.

4.5.6 Fertiliser application

All farmers applied urea at an average rate of 255 kg/ha (117 kg/ha of nitrogen), and additionally a variety of compound fertilisers viz., 20:20:0, 19:19:19, 17:17:17, di-amonium phosphate, 12:32:18 and 14:28:28. Potash was applied by 13 farmers at an average rate of 52 kg/ha (average of the 13 farmers). No clear relation was found between yield and fertiliser application, except for zinc (Zn, average application of 12 kg/ha), resulting in an increase in yield of 27 kg/ha, explaining 7.6% (AdjR²) of the yield variability ($p = 0.02$). This result is in agreement with Venkateswarlu (2001) and Rao (1995) indicating that the soils in the area are deficient in Zn and respond well to Zn application. Zinc applied as basal dressing was more effective ($p = 0.026$) than as top-dressing and accounted for 7.0% of the yield variability (AdjR²).

The number of fertiliser applications varied from two (5x), three (41x) to four (9x). Number of fertiliser applications had a significant effect ($p = 0.004$), with an increase in yield of 948 kg/ha for each additional fertiliser application. The

Pearson Correlation did not indicate significant correlation between number of fertiliser applications and rate of application of N, P₂O₅ and K₂O, therefore, no confounding effect of number and rate of fertiliser application was observed.

Basal dressing showed a weak correlation with yield, explaining 4.8% (AdjR²) of the variability ($p = 0.060$). Depth of standing water during fertiliser application did not affect yield ($p = 0.436$), probably because most farmers applied fertiliser with minimal water on the field. The relation between date of fertiliser application and yield was not significant. This might be associated with the wide variability in fertiliser application regimes followed by the farmers, who indicated that they often did not adhere to recommendations (with reference to timing and quantity). The effect of application of N, P₂O₅ and K₂O did not show any significance corroborating reports by Reddy and Raidu (1995) and Venkateswarlu (2001) that the soils in the area are high in potash and phosphorus

4.5.7 Weeding

Two thirds (36x) of the farmers in the area weeded twice during the crop growth cycle and another third once. Regression analysis shows that weeding twice reduced yield by 966 kg/ha (AdjR² = 11.5%; $p = 0.007$). Smith and Moody (1979) report that lack of irrigation water and poor water management, constraints in the area aggravate weed problems. Weeding is done by hand and timing is dictated by labour availability, rather than by considerations of effectivity with respect to minimising weed completion (Moody, 1992).

4.5.8 Pests and diseases

Farmers did not report major pest and disease problems. Regression showed non-significant relations for most pest types and yield, except for that of rodents ($p = 0.070$). Method and date of pesticide application also did not show any significant correlations. Minor damage due to insects was reported but with a poor significance ($p = 0.071$).

4.5.9 Water shortage

Eleven farmers reported water shortages at the flowering stage; sixteen reported irregular supply and twenty-eight did not report water shortages. Water shortage explained 21.9% (AdjR²) of the yield variability ($p = 0.00018$).

Yields were 1232 kg/ha higher in fields where no water shortage had been reported. Reported groundwater extraction rates from the tube wells in the area ranged from 60 to 300 litres per minute. Since Rabi rice depends on irrigation (mostly from tube wells), water yields may become critical. Regression showed a significant relation between groundwater yield and rice yield. Yields increased by 7.5 kg/ha with an increase of one litre/minute in groundwater yield, which explained 6.3% (AdjR²) of the yield variability ($p = 0.03$):

$$\text{Yield} = 5187 + 7.5 * \text{litres per minute}$$

4.5.10 Date of harvesting (length of growing season) (with reference to January 1, 2002)

Regression analysis on effect of date of harvesting on yield indicated that delayed harvesting resulted in a yield loss of 42 kg/ha/d ($p = 0.0003$) and explained 20.5% of the yield variability. According to the analysis, optimum harvesting time is 93 days after transplanting, while the average was 107 days.

4.6. Multiple Regression

Various management factors have been discussed in the previous sections, showing a significant influence on rice yields. A linear model was derived through a step-wise forward multiple regression (Table 4.1). The model explains yield variability through five independent variables having a significant impact on yield ($P < 0.00$) and has an Adjusted R² of 55.7%. The Durbin-Watson $d = 1.935$ is close enough to 2.00 for the null hypothesis of zero auto-correlation to be rejected.

The model did not include variables such as soil type, application of Zn (total and/or basal) and date of transplanting. The stepwise algorithm preferred date of harvesting (length of growing season) to date of transplanting, number of fertiliser applications to application of Zn. Water shortage and groundwater yield have been selected, because shortage of irrigation water refers to both, availability and accessibility. Most tube well pumps are power-driven and the power situation in the area is critical with less than nine hours of supply, while the requirement according to local farmers is at least 18 hours. Therefore, farmers who reported water shortages of water do not necessarily refer to inadequate groundwater yields from their tubes, but also to power shortages. Where groundwater yields are low, the problem of water availability is

aggravated through power shortages. As Rabi rice is dependent on irrigation water from tube wells, the water component (responses of farmers to both, water shortages and groundwater yields) shows a significant impact on yield. The coefficient for date of harvest declined from 42 to 31 (kg/ha); auto correlation to explain this decline could not be detected. The coefficient estimated for 'weeding done for a second time' is negative, which could be associated with damage to the crop during weeding., as the second (weeding by hand) weeding was done between 40 and 60 days after transplanting (during the reproductive phase of rice).

Table 4.1: Multiple regression model and causes of yield variation in Rabi rice -2001-2002.

| Linear Multiple Stepwise Regression | 5- Step Model AdjR ² = 55.7% S.E = 1392; Mean = 6521 | | |
|--|---|------------------|-------------|
| Dependent variable = Rice Yield (kg/ha) N = 55 | | | |
| Independents | R ² when entered | Coeff. Constant: | Probability |
| | | 7393.00 | |
| If no water shortage | 22.6 | 1169.83 | 0.0% |
| Date of Harvesting (ref 01.01.02) | 45.2 | -31.88 | 0.0% |
| If weeding done a 2 nd time (by hand) | 51.2 | -602.49 | 1.8% |
| Ground water yield (Litres Per Minute) | 56.4 | 5.44 | 3.1% |
| With each increase in the Number of Fertiliser application (2 or 3 or 4) | 59.8 | 490.83 | 4.5% |

The yield prediction model derived from the multiple regression analysis is:

$$Y = 7393 - (31.88 * \text{Date of harvesting ((length of growing season)))} + (1169 * \text{no water shortage} - (602 * \text{if weeded twice}) + (490 * \text{number of times fertiliser applied}) + (5.4 * \text{groundwater yield (l/min))$$

This 5-step model is used for more detailed analysis. The regression residuals of the 5 independent variables are normally distributed P = 96% (Figures 4.7 and 4.8), and the relation between predicted and reported yields (Figure 4.9) is:

$$\text{Predicted Yield} = 2641.4 + 0.82181 * \text{Reported Yield} \quad (\text{Adj R}^2 = 0.6686)$$

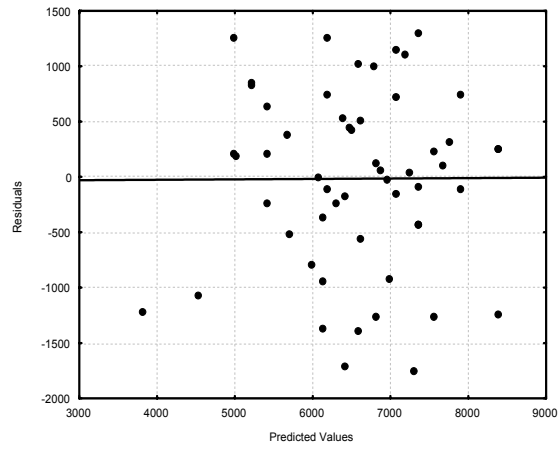

Figure 4.7. Residuals against predicted values

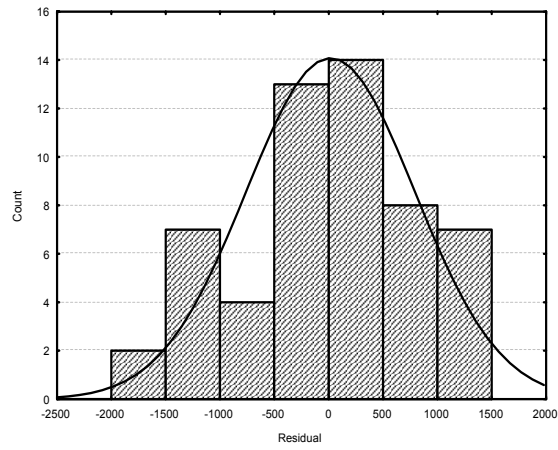

Figure 4.8. Distribution of residuals

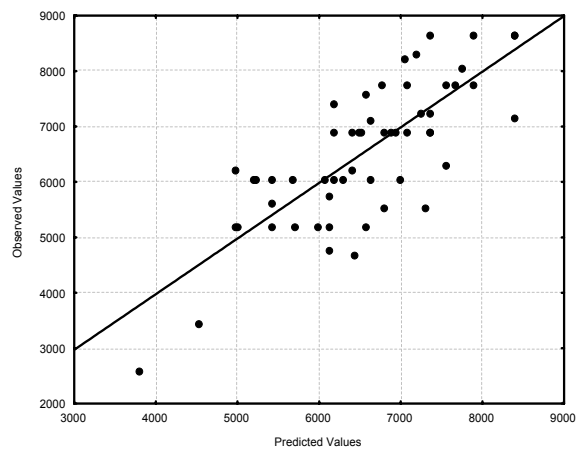

Figure 4.9. Scatter plot of predicted versus reported yields

4.7 Yield gaps and yield constraints

The contribution of each of the yield constraints to the overall yield gap in the 5 variable model is given in Table 4.1. The contribution of a yield constraint to the R^2 of a model is not necessarily related to its contribution to the overall yield gap (de Bie, 2000). The latter is established by comparing the average value of a particular constraint for the 55 plots with their best values. Estimated and actual yields tally for the 'average' and 'best' yields (Table 4.2). The yield gap of 2099 kg/ha could be attributed to: water shortage (27%), date of harvesting (21%), second weeding (19%), inadequate groundwater yields (11%) and number of fertiliser applications (22%). Only groundwater yield is a site-specific land property.

These results indicate that more attention is required by the extension services to advise farmers on more efficient use of fertilisers, the importance of timely harvesting, water management and weeding.

4.8 Discussion and Conclusions

Research supporting realisation of the crop management improvement objective for the study area focused on understanding the determinants of yields of the dominant crop, Rabi rice. The farmers in the area showed keen interest in sharing their knowledge on rice cultivation, and, more importantly, they looked for suggestions and 'guidance' for increasing their yields. Groundwater forms the primary source for irrigation in the dry season and detailed study of groundwater could contribute to improvements in the yield model. The soil data base available for this study was 'generic'. Detailed information on soil characteristics at field level should be incorporated in the model to further explain yield variability. Identification of the reasons underlying the apparently low fertiliser use efficiencies warrants further study. Remote sensing imageries were useful in cross-checking the validity of farmers' claims of having grown Rabi rice. Mobile GPS was useful in geo-referencing the field boundaries and location of interviews.

In this study a number of biophysical variables have been analysed with respect to their influence on rice yields. However, as discussed by Tran (1999), narrowing the yield gap of rice requires integrated and holistic approaches, including appropriate conceptualisation, policy intervention, understanding of

farmers' actual constraints in achieving high yields, design of new technologies and promotion of integrated crop management, adequate supplies of inputs and availability of farm credit and strengthening of research and extension and linkages to them. If one of these components is missing or weak, narrowing the yield gap in a particular rice production area cannot realise its full potential.

Table 4.2: Breakdown of the yield gap of Rabi rice in Kotgir and Birkur mandals by yield constraint (Kg/ha; 2001-2002 Rabi season)

| Independents | Coeff. | Measured Values | | Measured values * Coeff. | | Partial Yield Gap | Percent contribution to Yield Gap |
|--|---------|-----------------|--------|--------------------------|-------------|-------------------|-----------------------------------|
| | | Avg | Best | Avg | Best | | |
| Constant | 7393.00 | 1.00 | 1.00 | 7393.00 | 7393.00 | 0.00 | |
| If no water shortage | 1169.83 | 0.51 | 1.00 | 595.44 | 1169.80 | 574.40 | 27% |
| Date of Harvesting (ref 01.01.02) | -31.88 | 107.00 | 93.00 | 3411.20 | 2964.80 | 446.32 | 21% |
| If weeding done a 2 nd time | -602.49 | 0.65 | 0.00 | -391.62 | 0.00 | 391.62 | 19% |
| Ground water yield (Litres Per Minute) | 5.44 | 157.63 | 200.00 | 857.51 | 1088.00 | 230.49 | 11% |
| With each increase in the Number of Fertiliser application (2 or 3 or 4) | 490.83 | 3.07 | 4.00 | 1506.85 | 1963.32 | 456.47 | 22% |
| Estimated Yields (Kg/ha) | | | | 6550 | 8649 | | |
| Actual Yields (Kg/ha) | | | | 6522 | 8649 | | |
| | | | | | | 2099 | |

Close collaboration is essential between research, extension, local authorities, NGOs and the private sector to identify specific constraints and take concerted action to narrow yield gaps of rice through participatory approaches (Tran, 1999). Such actions should be predominantly driven by participation of the local farmers with information on their land use practices, i.e. a 'bottom-up' approach should be followed in achieving the crop management improvement objective for the study area. The major role of the researcher is to analyse the results, support identification of major yield constraints and design alternative

technologies that could be useful to the extension agencies and farmers in the area.

In Chapter 5, we develop analytical methods in the areas identified for Crop Selection (CS) for interactively evaluating strategic land use options. Pitlam mandal with a significant area identified for crop selection as discussed in Chapter 3. A multiple goal optimisation model is developed which considers, among others, yields, market prices (of inputs and outputs), labour requirements, water availability, policy and local preferences. The outcome of the model is then linked to a stakeholder communication matrix to identify bottlenecks in the utilisation of the model as a negotiation support tool. This chapter build on and links to the recommendations in chapter 2 of developing what if? scenarios. Integration of bio-physical with social dynamics (hard and soft systems) among stakeholders is also demonstrated.

References

- Asch, F., Wopereis, M., 2001. Responses of field grown irrigated rice cultivars to varying levels of floodwater salinity in a semi-arid environment. *Field Crops Research* 70, 127-137.
- Becker, M., Johnson, D.E., 1999. Rice yield and productivity gaps in irrigated systems of the forest zone in Côte d'Ivoire. *Field Crops Research* 60, 201-208.
- Brouwer, C., Prins, K., Heibloem, M., 1989. *Irrigation Water Management: Irrigation Scheduling* 4, FAO, Rome.
- Casanova, D., Goudriaan, J., Bouma J., Epema, G.F., 1999. Yield gap analysis in relation to soil properties in direct-seeded flooded rice. *Geoderma* 91, 191-216.
- Census of India., 2001. Andhra Pradesh, Provisional Population Totals. Paper 3 of 2001, Director of Census Operations, Hyderabad, India.
- Chief Planning Officer., 2001. *Hand Book of Statistics - Nizamabad District*, Chief Planning Officer, Nizamabad, Andhra Pradesh, India.
- de Bie, C.A.J.M., 2004. The yield gap of mango in Phrao, Thailand, as investigated through comparative performance evaluation. *Scientia Horticulturae*. In Press. Corrected proof available online.
- de Bie, C.A.J.M., 2000. *Comparative performance analysis of agro-ecosystems*, Ph.D. Thesis, Wageningen University, Wageningen.
- Dingkuhn, M, Sow, A., Samb, A., Diack, S., Asch, F. 1995. Climatic Determinants of Irrigated Rice Performance in the Sahel - I. Photo-thermal

- and Micro-climatic Responses of Flowering. *Agricultural Systems* 48, 385-410
- Duwayri, M., Tran, D.V., Nguyen, V.N., 2000. Reflections on Yield Gaps in Rice Production: How to Narrow the Gaps. Food and Agriculture Organization of the United Nations, Regional Office for Asia and the Pacific, Bangkok, Thailand.
- Frank, H., Althoen, S.C., 1995. *Statistics: Concepts and applications*. Cambridge University Press, Cambridge, UK. 853 pp.
- Herd, R.W., 1982. Focusing field research on future constraints to rice production. research paper series-76. IRRI, Los Baños, The Philippines. 18pp
- Moody, K., 1992. Weed management in wet-seeded rice in tropical Asia, International Rice Research Institute, Los Banos, Laguna, Philippines.
- Poussin, J., Wopereis M.C.S., Debouzie, D., Maeght, J.L., 2003. Determinants of irrigated rice yield in the Senegal River Valley. *European Journal of Agronomy* 19, 341-356.
- Rao, S.V.C.K., 1995. Cropping pattern analysis using temporal IRS-LISS II data- A case study of Madnur watershed, Nizamabad district, AP, Indian Institute of Remote Sensing, Dehradun, India.
- Reddy, K.C.K., Raidu, D.V., 1995. *Fertilisers. Soils of Andhra Pradesh - A Monograph*. Andhra Pradesh Agricultural University and Hyderabad Chapter of Indian Society of Soil Sciences, Rajendranagar, Hyderabad, India. 422 pp.
- RWC., 2003. *Rice-Wheat Consortium for the Indo-Gangetic Plains*, CIMMYT-India, New Delhi, India.
- Savary, S., Srivastava, R.K., Singh, H.M., Elazegui, F.A., 1997. A characterisation of rice pests and quantification of yield losses in the rice-wheat system in India. *Crop Protection* 16, 387-398.
- Siddiq, E., 2000. Bridging the Rice Yield Gap in India, Food and Agriculture Organization of the United Nations, Regional Office for Asia and the Pacific (RAP), Bangkok, Thailand.
- Singh, S., Kumar, U., Gautam, U.S., Sinha, S.K., Rahman, A., 2002. Groundwater Development to Enhance Surface and Rain Water Utilization and Agricultural Productivity in Southern Bihar, IWMI-TATA Water Policy Research Program.
- Smith Jr, R.J., Moody, K., 1979. Weed control practices in rice. In Kommedahl (Ed): *Integrated Plant Protection for Agricultural crops and forest trees*. 9th International Congress of Plant Protection, 2, T. Washington DC, 458-462.
- Tiwari, K., 2002. Rice production and nutrient management in India. *Better Crops International*, 16 (Special supplement, May 2002), 18-22.

- Tran, D., 1999. Reflections on yield gaps in Rice Production. Food and Agriculture Organization of the United Nations, Regional Office for Asia and the Pacific (RAP), Bangkok, Thailand.
- Venkateswarlu, J., 2001. Management of Soils of Andhra Pradesh. Acharya N.G. Ranga Agricultural University, Hyderabad, India.

Chapter 5

Integrating Multiple Goal Linear Programming and Inter-Stakeholder Communication Matrix to generate Land Use options

Abstract

Land use is dynamic and the result of farmers' decisions in the context of the prevailing biophysical and socio-economic conditions. It is important to understand the relationship between socio-economic conditions and land use to allow possible adjustment of socio-economic conditions through policy measures, in a way that allows land users to make the right strategic, tactical and operational decisions at each point in time. A Multiple Goal Linear Programming (MGLP) model is developed that considers objectives of multiple stakeholders, such as small and medium farmers, large-scale farmers, district agricultural officers and agricultural scientists. The analysis focuses on crop selection; ten cropping activities considering irrigated and non-irrigated crops such as rice, sugarcane, sorghum, cotton, millet, pulses and groundnut have been identified. Interests of a sample of the most important stakeholders: farmers, policy makers and the water users association are investigated. Two important objectives of the farmers are: increased income and retaining paddy area. Objectives of the policy makers include increased farmers income, maintaining rural employment, improve water-use efficiency, reduce fertiliser and biocide use and discourage farmers from cultivating marginal lands. The water user association's main objective is optimising water use. A number of scenarios can be constructed by different combinations of objectives and constraints. Three examples are discussed relating to a) Maximise profit; b) Minimise water use; c) Maximise employment. In each of the scenarios four options are explored: maintain the current paddy area; 50% reduction in the current paddy area; reduction of 20% in agriculture area, while maintaining the current paddy area; reduction of 20% in agricultural area and 50% in paddy area. The Stakeholder Communication Matrix (SCM) indicating the level of communication and information flow among stakeholders in the district was generated after a PRA conducted in the area. Sample scenarios generated with the MGLP model based on the objectives of the stakeholders were compared with the matrix. The relevance of analysing the results of the scenarios generated with the MGLP model in the context of a SCM is illustrated with a sample set of scenarios. In Scenario 1 (S1) paddy area is retained at the current level and no reduction in agricultural area is preferred by the farmers. However, the Agricultural Department would identify more easily with a scenario such as Scenario 10 (S10) in which the paddy area is reduced by 50% and the agricultural area by 20%, in accordance with the policy of

limiting the area of high water-demanding crops and dissuading farmers from cultivating the marginal lands. This conflicting situation is compounded by the fact that communication between small-scale farmers and the agricultural department is relatively weak. Another example is the conflict between scenarios 1 and 12. In this case, farmers prefer S1, while the Water Users Association's objective is minimising water use (scenario 12), i.e. encourage cultivation of crops that are relatively less water-demanding and thus its preference is S12. Compared to S1, income in S12 is 22% lower, while water use is 36% lower, and there is a significant reduction in biocide use. Therefore, analysing the scenarios generated with the MGLP model in the context of the SCM can be useful to gain insight in the interactions among stakeholders in the system and take curative measures if required for improved communication. While the MGLP model considers the bio-economics of the land use system, the SCM describes the social aspects of the system, which is critical for successful implementation of the MGLP model.

Key words: Multiple Goal Linear Programming (MGLP), Stakeholder Communication Matrix, Crop Selection Modelling, Scenarios.

Based on: Uday Bhaskar Nidumolu, Herman van Keulen, Marcel Lubbers and Andrew Mapfumo. Integrating Multiple Goal Linear Programming and Inter-Stakeholder Communication Matrix to generate Land Use options. *(In Review: Agricultural Systems)*

5.1 Introduction

Traditional land use analysis approaches have relied heavily on land evaluation and land suitability models. However, as decisions on land use are co-determined by social and economic criteria, information on biophysical suitability alone is not sufficient for land use planning (Huizing and Bronsveld, 1994). In situations where many different (groups of) stakeholders have an active interest in the way the land is (being, or going to be) used, new methodologies for land use studies are required as a basis for formulation of land use policies. In these methodologies, the aims and aspirations of the different stakeholders have to be taken into account, but they should be based on thorough knowledge of the agro-technical possibilities and socioeconomic boundary conditions under which land use has to take place (van Keulen et al., 2002). Agricultural policies should aim at directing agricultural development in a way that leads to attaining a number of socio-economic goals. These include increased production, employment and profit, but also other goals such as environmental stability, pollution abatement and political compensation. A feasible development objective must consider all these goals imposed on a region (de Wit et al., 1988). Such agro-ecological-social systems are complex and therefore difficult to model and no blue print solution exists. Policy makers have to consider different policy options and at the same time learn-by-doing (Holling et al., 1998). As learning-by-doing is time-consuming and as experiments are costly or may be impossible, the use of models may be helpful. By carrying out computer experiments and carefully analysing the results, such models may increase insight into the dynamics of these complex systems (Struif Bontkes and van Keulen, 2003). The models should aggregate the results in such a way that possibilities and limitations, relationships and interdependencies become explicit (Zander and Kächele, 1999). It is especially important to identify conflicting goals and to explicitly quantify the trade-offs among the multiple goals that contribute to sustainable agriculture (Romero and Rehman, 1989; van Kooten, 1993). One such modelling technique is multiple goal linear programming (MGLP), that has been widely used to integrate different types of information and to generate land use scenarios (de Wit et al., 1988; Rabbinge and van Latesteijn, 1992; Chuvieco, 1993; van Keulen et al., 1998; van Ittersum et al., 1998; Zander and Kächele, 1999; Sujith Kumar et al., 2001; Sarkar and Quaddus, 2002; Hengsdijk and van Ittersum, 2002; Lu et al., 2002; Dogliotti, 2003; Lu et al., 2004; Kaur et al., 2004).

In this study we develop a Multiple Goal Linear Programming model and discuss it in the context of stakeholder-communication in the study area. The stakeholder-communication context is important, because the MGLP model is expected to be applied as a negotiation support tool and communication is critical for negotiation. As land use is dynamic and co-determined by socio-economic conditions, it is important to understand the relationship between socio-economic conditions and land use to be able to adjust socio-economic conditions in a way that allows land users to make the right strategic, tactical and operational decisions at each point in time (Ganzert, 1995, as cited in Zander and Kächele, 1999). This requires communication and is only attainable if some kind of institutionalised driving force for sustainable development can be established (Röling, 1994). While several studies have used MGLP as a modelling tool for land use planning, an 'explicit' integration with Stakeholder Analysis (SA; though there is an implicit association with SA) has not been reported, nor has the use of a Stakeholder Communication Matrix (SCM) as a means of identifying bottlenecks in acceptance of the MGLP output. In formulating land use policies, many stakeholders at different levels are involved, e.g., primary stakeholders, including small and large-scale farmers, secondary stakeholders, i.e. planning and enforcement officials and policy makers, each with their own 'agenda', but with the overall objective of the 'development' of a particular area they are responsible for. Stakeholders, both primary and secondary, do not live in isolation but in a society, they communicate and share information on issues related to development, in this instance agricultural development, as the study focuses on agricultural land use. For the MGLP modelling exercise to be effective, the interactions and communication between the different stakeholders should be understood. Such understanding will assist in identifying bottlenecks in communication, and analysing the reasons and eventually removing them, will significantly improve interactions among stakeholders. We argue that the options generated with an MGLP model can be effectively implemented only when there is communication and information-sharing among various stakeholders, i.e. platform building (Clayton et al., 2003). Assuming that objectives of various stakeholders are known and can be analysed in the context of an SCM, a broad understanding of the attitudes of these stakeholders towards the outcome of the MGLP model may be achieved. For example, if objectives among stakeholders are conflicting, a strong communication links among them may facilitate finding a solution. However, if the communication links are relatively weak among stakeholders with conflicting objectives, our recommendations could include improving these communication channels, so that the MGLP outcome

can be fully utilised. In a land use analysis cycle, MGLP analysis can be considered a discussion phase with participation of the stakeholders involved. SCM is a useful tool for understanding the dynamics of the communication between stakeholders for effective land use policy formulation. While MGLP serves as a quantitative modelling tool, SCM represents qualitative information, reflecting the communication among the various stakeholders.

The work reported in this paper has been conducted in the context of a large land use planning programme initiated by the Government of India called the 'Integrated Mission for Sustainable Development', covering about 83 million hectares. Output of the project comprises land and water management 'action plans', to be implemented by District level resource managers. Databases on biophysical characteristics, such as soils, terrain, land cover and groundwater are available at 1:50,000 scale along with land suitability data (NRSA, 1995; Nidumolu and Alanga, 2001; Harmsen and Nidumolu, 2002). The main objective of the current study is development of an MGLP model and its integration with the SCM as a support tool in negotiating a sustainable crop selection for the study area by various stakeholders.

5.2 Study area

The study area is Pitlam mandal, Nizamabad District, Andhra Pradesh State in India (Figure 5.1), with an area of 19,292 hectares. The population of the area is 41,847 according to the 2001 census. The major land cover categories are agriculture (6170 ha), forests (3811 ha) and wastelands (3380 ha). Annual average rainfall is about 990 mm. Of the farmers' holdings 96% is less than less than 2 ha (small- and marginal-scale farmers, (FAO, 2002). This category of farmers owns about 81% of the agricultural area, the remainder being owned by farmers with greater than 4 ha holdings (medium to large-scale farmers). Two agricultural seasons can be distinguished: Kharif - rainy season between June and October and Rabi - post-rainy season from November to March. In Kharif, 2884 ha (out of 6170 ha) have irrigation facilities and in Rabi 2399 ha (out of 3944 ha). Tanks and tubewells constitute the majority of the irrigation sources (Figure 5.2). Paddy rice is the dominant crop with about 2700 ha cultivated in Kharif and about 1000 ha in Rabi. Sorghum (*Sorghum bicolor* (L.) Moench), green gram (*Vigna radiata*), black gram (*Vigna mungo*), sugarcane, cotton and groundnut constitute the other crops (Figure 5.3).

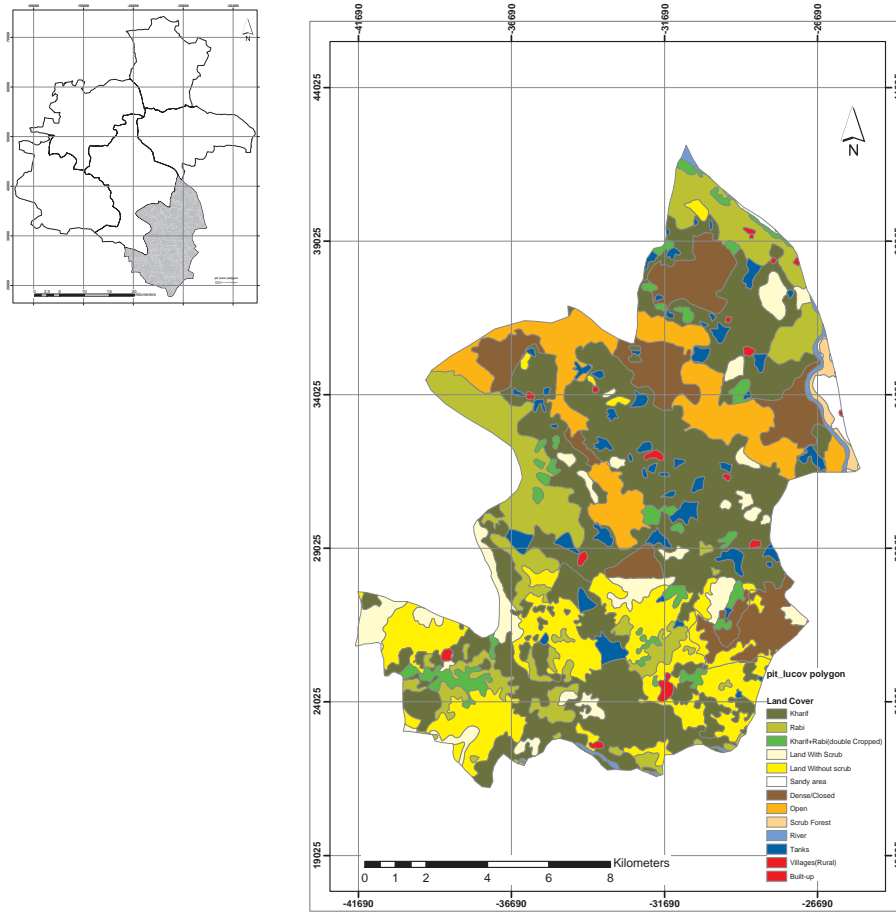

Figure 5.1. Land cover map of Pitlam Mandal

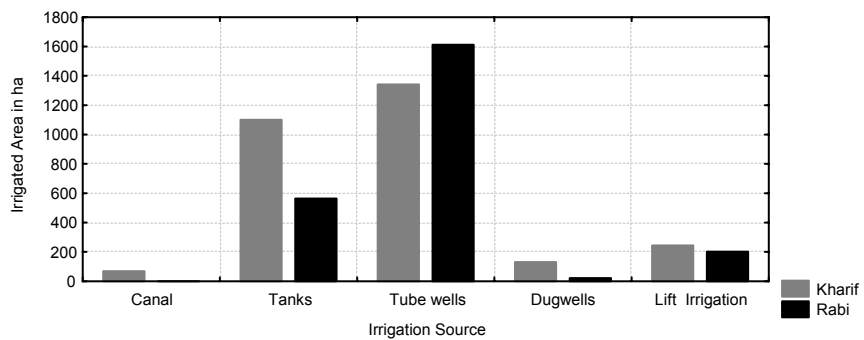

Figure 5.2. Irrigation sources and area irrigated

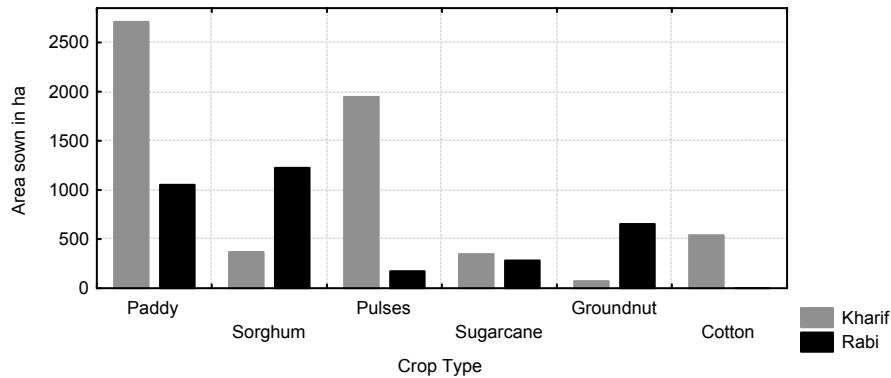

Figure 5.3. Crop type and areal extent (%) in Kharif and Rabi seasons (CPO, 2001)

5.3 Method

The conceptual model applied in the study is presented in Figure 5.4. First, we conducted a stakeholder analysis between June and December 2002 and developed the stakeholder communication matrix based on interviews with individual stakeholders. Second, we developed an MGLP model. The technical coefficients, describing a set of agricultural activities were derived from published statistics of the area, surveys, expert knowledge and stakeholder input. Moreover, resources and constraints were defined. The stakeholders identified the objectives. A number of scenarios can be generated with these combinations. Thirdly, we integrated the MGLP and Stakeholder communication matrix to identify bottlenecks in the possible adoption of the results of the MGLP model scenarios. The scenarios, that are acceptable to the stakeholders, depend on the level of communication among the various stakeholders. SCM provides a framework for identification of possible bottlenecks that might affect the adoption of the results of the MGLP scenarios. We now describe the details of the development of the MGLP model and the SCM for the study area. The MGLP model has been developed with a facility to incorporate additional functionalities over time and depending on the changing circumstances (activities such as new crop types, new technologies, changes in parameters including costs and prices of products, population dynamics, labour, change of dietary preferences, changes in infrastructure).

5.3.1 The MGLP model for Pitlam Mandal

A linear programming model is designed to optimise an objective function while respecting a set of constraints; both the functions and constraints are

formulated as linear equations (Chuvieco, 1993). An MGLP model, that is designed to optimise a number of objective functions in successive iterations, has four components (a) Objectives, (b) Constraints, (c) Activities or decision variables and (d) Scenarios. In the present study, we conducted a participatory rural appraisal and a stakeholder analysis in the first phase to specify the model components a, b and c.

Objectives

Based on societal, economic, environmental and policy concerns, seven objectives have been defined: (i) Economic: maximising farm income, minimising costs of production; (ii) Social: maximising food production; (iii) Government/policy: minimising agricultural area, maximising employment, minimising water use; (iv) Environmental: minimising fertiliser use, minimising biocide use. The objectives of the various stakeholder(s) (groups) are given in Table 5.1. The equations are given in Appendix 5.1 and the formulation is given in Appendix 5.2.

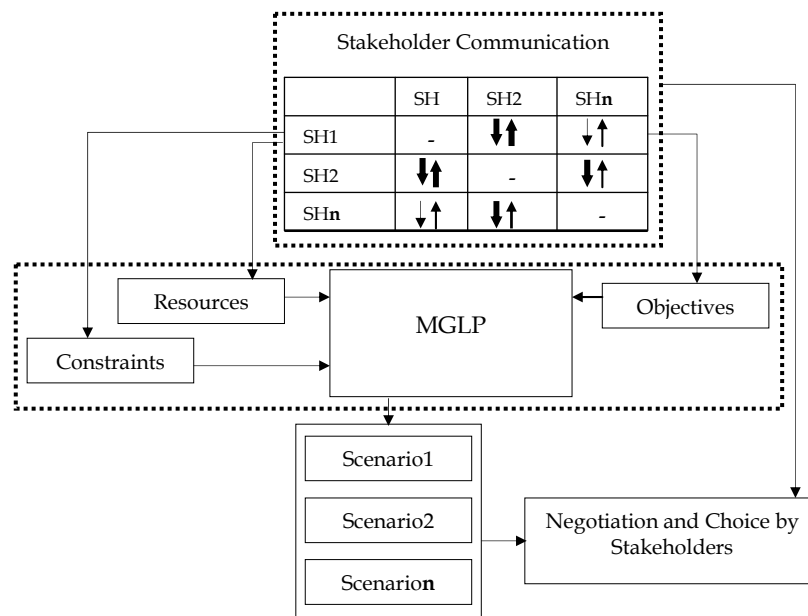

Figure 5.4. Conceptual model of integrating MGLP and Stakeholder Communication Matrix.

Constraints

The constraints relate to the resources available and include land, labour, capital and water: (i) Land allocated to various activities cannot exceed total agricultural land available, (ii) Labour allocated to the various activities cannot exceed the total available labour force, (iii) Costs cannot exceed total available capital, (iv) Water use cannot exceed total available water. In addition, the objectives not being optimized in a particular optimisation (can) act as constraints.

Activities

The analysis focuses on crop selection, therefore livestock activities are not considered in the model. Ten cropping activities have been identified as relevant for the current study: (i) Paddy Kharif_irrigated, (ii) Paddy Kharif_non-irrigated, (iii) Cotton Kharif_non-irrigated, (iv) Sorghum Kharif_non-irrigated, (v) Sorghum Rabi_non-irrigated, (vi) Green gram Kharif_non-irrigated, (vii) Green gram Rabi_non-irrigated, (viii) Black gram Kharif_non-irrigated, (ix) Black gram Rabi_non-irrigated, (x) Groundnut Kharif_non-irrigated. Only current technology level is considered, as the majority of the farmers are small to medium-scale and significant technology-related modifications are not foreseen in the near future. However, there is a provision in the model to incorporate different technology levels at a future date.

The technical coefficients have been derived from statistical records from the study area, field surveys, interviews with stakeholders and published literature (CPO, 1995 and 2001). The model was formulated in General Algebraic Modelling System Integrated Development Environment (GAMS IDE) (GAMS, 1998).

Scenarios

In this paper we consider the interests of a sample of the most important stakeholders: farmers, policy makers and the water users association. In the study area, two important objectives of the farmers are: increased income and retaining paddy area. The objectives of the policy makers include increased farmers income, maintaining rural employment, improve water-use efficiency, reduce fertiliser and biocide use and discourage farmers from cultivating marginal lands. The water user association's main objective is optimising water use. A number of scenarios can be constructed by different combinations of objectives and constraints. We discuss three examples:

- a) Maximise profit
- b) Minimise water use
- c) Maximise employment

In each of the scenarios the following four options are explored:

- (i) Maintain the current paddy area
- (ii) 50% reduction in the current paddy area
- (iii) Reduction of 20% in agriculture area, while maintaining the current paddy area
- (iv) Reduction of 20% in agricultural area and 50% in paddy area

Rice is the staple diet for the population of the region and because of food security considerations prefers to maintain the current paddy area. However, the policy of the District administration aims at reducing the paddy area, because of water-related limitations. Therefore, reducing the current paddy area by 50% is explored as an option.

A reduction of 20% in agricultural land is explored to mimic abandonment of marginal lands currently under cultivation. The reduction is confined to Kharif_ and Rabi_non-irrigated lands that comprise these marginal lands. The Pitlam MGLP model, containing equations 1-11 from Appendix 5.1 and the technical coefficients, has been used to generate the objective values for the different scenarios (Table 5.2). The formulation of the Pitlam Model is given in Appendix 5.2.

In Scenario 1 (S1), maximising income while maintaining the current area of paddy (3763 ha), leads to a high level of biocide use (Table 5.2), as a consequence of a 2576 ha being allocated to cotton (on which significant quantities of biocides are used). Scenario S2, where employment creation is maximised, leads to a 30% increase in labour use, a 44% reduction in income and about a five-fold reduction in biocide use, compared to S1. The reduced biocide use is the consequence of complete disappearance of cotton from the cropping pattern, while other commercial crops, such as sugarcane (1009 ha) and groundnut (981 ha) compensate for income generation. If the current paddy area and yields have to be maintained, reducing water use is not possible. Therefore, in this option (S3), in addition to the current paddy area, sugarcane (1615 ha) and groundnut (496 ha) are cultivated. When S3 is compared to S9, where water use is minimised, associated with a reduction of 50% in paddy

area, a significant reduction (59%) in water use is achieved. Alternative crops in the latter case are cotton (1479 ha), green gram (1545 ha) and groundnut (2884 ha).

Interactive workshop with stakeholders

An interactive workshop was conducted in January 2004, where the MGLP model was demonstrated and several scenarios were generated and discussed with the stakeholders. There was enthusiastic participation and keen interest among the planners and the farmers to further explore the tool. It is intended to install the modelling tool in the district planning office where adequate facilities are available.

Table 5.1: Stakeholder objectives

| | Max food production | Max Income | Max labour use | Min agric area | Min fertiliser use | Min biocide use | Min water use |
|---|---------------------------|---------------|----------------------|----------------------|--------------------------|-----------------------|---------------------|
| Marginal/small scale farmer | ✓ | - | - | - | - | - | - |
| Large scale farmer | - | ✓ | - | - | - | - | - |
| District Agricultural Dept. | ✓ | - | - | ✓ | ✓ | ✓ | ✓ |
| District Rural Development Agency | ✓ | ✓ | ✓ | ✓ | ✓ | ✓ | ✓ |
| Water Users Association | ✓ | - | - | - | - | - | ✓ |
| Agricultural Research Station/ Scientists | ✓ | - | - | ✓ | ✓ | ✓ | ✓ |
| Extension Service | ✓ | - | - | - | ✓ | ✓ | ✓ |

5.3.2 SCM development

As discussed earlier, we developed a MGLP model as a negotiation support tool in agricultural policy formulation at regional level. It is understood that while the policies are formulated at regional level, their implementation has to be realized at individual farms. Therefore, the stakeholders in the negotiations range from small farmers to District agricultural officials. For the negotiations to be successful there is a need for communication among the various stakeholders. To assess the current level of communication among the

stakeholders, a SCM was developed, on the basis of a stakeholder analysis, conducted in the study area with sixteen stakeholder categories over a period of several months during 2002.

Stakeholder analysis is a powerful tool for policy analysis and formulation, and has considerable potential in natural resource policy and programme development. It has been developed in response to the challenge of multiple interests and objectives, and particularly the search for efficient, equitable and environmentally sustainable development strategies (Grimble and Wellard, 1997). Stakeholder analysis aims at analysing how stakeholders interrelate, what multiple "hats" they may wear, and what networks exist (Ramirez, 1999). For the effectiveness of agricultural policy implementation, information sharing is the most important factor. Understanding of patterns, relationships and context of interactions among stakeholders is one of the key steps in stakeholder analysis. The study analyses the type of information that is shared among the stakeholders and how the information flows. In the study area, the relations among stakeholders are complex and at the centre of attention is the farmer who is the primary stakeholder. Figure 5.5 shows how the stakeholder setting within the land use sector at regional level.

A stakeholder communication matrix is a useful analytical tool for identifying and assessing the significance of conflicts of interest and co-operation among the stakeholders and as a way of analysing the need for information sharing among the different stakeholders (Grimble and Wellard, 1997).

In this study an SCM has been used as a way of analysing the subjects and mode of information-sharing among stakeholders. The stakeholder communication matrix (Figure 5.6) illustrates the way in which the stakeholders interact, and their level of interaction. The larger the circle, the more intensive the interaction among the stakeholders. We interviewed sixteen different groups of stakeholders, using different methods: brainstorming to generate ideas among the farmers, followed by semi-structured questionnaires for farmers and other stakeholders. The questions focused on key interests of the stakeholders, their influence on the land use system, and their participation in the process of land use planning. Inferences of each of these stakeholders' role, information-sharing, and communication among themselves were derived and a communication / information matrix was constructed.

The SCM developed in this way is *not* an objective picture for the area, but is based on our perceptions and discussions with the stakeholders involved. As socio-economic-political conditions are dynamic in nature, the matrix undergoes modifications, sometimes on a real-time basis. Therefore, it has to be constantly updated if it is to be appropriately consulted.

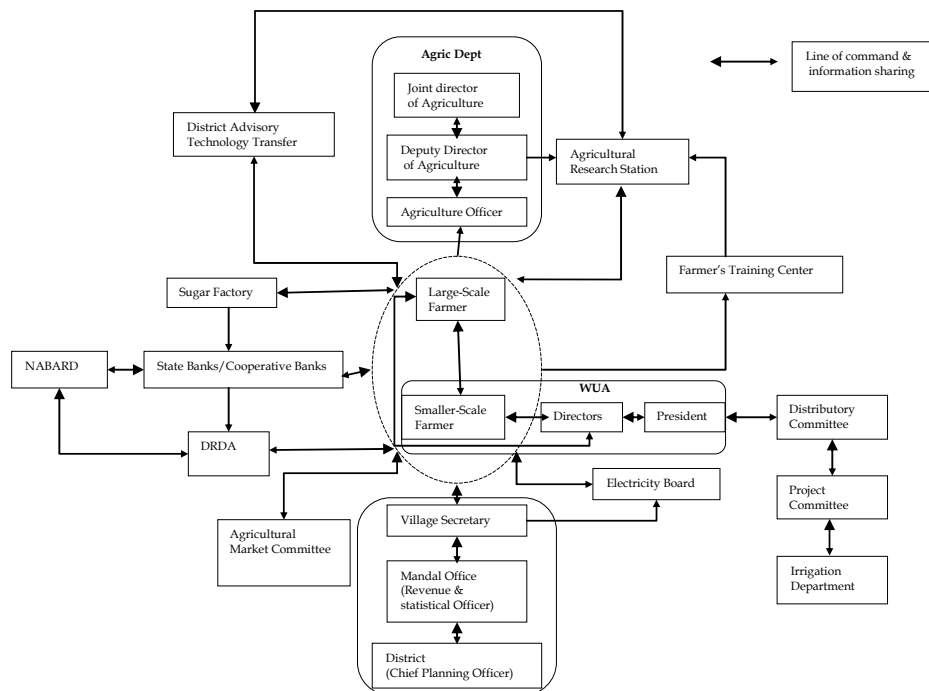

DRDA: District Rural Development Agency
 WUA: Water Users Association
 NABARD: National Agricultural bank for Rural Development

Figure 5.5. Stakeholder setting in the study area

Table 5.2: Objective values for different scenarios

| Scenarios | I (Rs '000) | L (Man- days '000) | F ('000 Kg) | B (kg) | W ('000 mm) | Paddy (ha) | | So (ha) | | SC (ha) | | Co (ha) | | GG (ha) | | BG (ha) | | G (ha) |
|-----------|-------------------|-----------------------------|-------------------|-----------|-------------------|------------|-------|---------|-------|------------|-------|------------|-------|---------|-------|---------|-------|-----------|
| | | | | | | Kirr | Rnirr | Rirr | Rnirr | Kirr | Rnirr | Kirr | Rnirr | Kirr | Rnirr | Kirr | Rnirr | |
| S1 | 30246 | 728 | 1139 | 7291 | 2908 | 2774 | - | 988 | - | - | - | 2576 | 1545 | - | - | - | - | 109 |
| S2 | 20917 | 948 | 1112 | 1391 | 2908 | 893 | 470 | 2399 | 2815 | 1545 | 1009 | - | - | - | - | - | - | 981 |
| S3 | 15606 | 831 | 1014 | 1368 | 2908 | 772 | 2990 | - | - | - | 1615 | - | - | - | - | - | - | 496 |
| S4 | 29376 | 728 | 1142 | 7271 | 2908 | 2628 | - | 1134 | - | - | - | 2579 | 1236 | - | - | - | - | 255 |
| S5 | 21093 | 921 | 1090 | 1386 | 2908 | 865 | 498 | 2399 | 2130 | 1236 | 1147 | - | - | - | - | - | - | 870 |
| S6 | 16522 | 831 | 1014 | 1368 | 2908 | 772 | 2629 | 361 | - | - | 1615 | - | - | - | - | - | - | 496 |
| S7 | 33211 | 593 | 965 | 8892 | 2139 | 1880 | - | - | - | - | 80 | 3286 | 1545 | - | - | - | - | - |
| S8 | 24701 | 863 | 914 | 1426 | 2220 | 1096 | - | 783 | 3286 | 1545 | 1787 | - | - | - | - | - | - | - |
| S9 | 21597 | 614 | 861 | 4784 | 1825 | - | 1806 | 73 | - | - | - | 1479 | 1545 | - | - | - | - | 2884 |
| S10 | 31686 | 620 | 933 | 7391 | 2144 | 1880 | - | - | - | - | 514 | 2629 | 1236 | - | - | - | - | - |
| S11 | 24877 | 836 | 892 | 1417 | 2209 | 1003 | - | 876 | 2629 | 1236 | 1880 | - | - | - | - | - | - | - |
| S12 | 23511 | 622 | 868 | 1498 | 1843 | - | 1048 | 831 | - | - | - | 1580 | - | - | - | 1236 | - | 2884 |

I-Income; L-Labour; F-Fertiliser; B-Bioicide; W-Water-used; So-Sorghum; SC-SugarCane; Co-Cotton; GG-GreenGram (pulses); BG-BlackGram (pulses); G-Groundnut; Kirr-Kharif irrigated; Rnirr-Kharif non-irrigated; Rirr- Rabi irrigated; Rnirr- Rabi non-irrigated

- S1: Maximise profit with current land and current level of Paddy area
- S2: Maximise employment with current land and current level of Paddy
- S3: Minimise water-used with current land and current level of Paddy a
current level of Paddy area
- S5: Maximise employment with 20% reduction in current land and
current level of Paddy area
- S6: Minimise water-used 20 % reduction in current land and with
current level of Paddy area
- S7: Maximise profit with current land and 50% of current level of paddy
- S8: Maximise employment with current land and 50% current level of Paddy
- S9: Minimise water-used with current land and 50% of current level of paddy
current level of Paddy area
- S10: Maximise profit with 20 % reduction in current land and with 50%
current level of Paddy area
- S11: Maximise employment with 20% reduction in current land and 50%
current level of Paddy area
- S12: Minimise water-used 20 % reduction in current land and with 50%
current level of Paddy area

5.4 Analysing the MGLP model and the Stakeholder Communication Matrix

The relevance of analysing the results of the scenarios generated with the MGLP model in the context of a SCM can be illustrated with a sample set of scenarios. For example, consider Scenario 1 (in Table 5.2), which is preferred by the farmers, as the paddy area is retained at the current level and there is no reduction in agricultural area. However, the Agricultural Department would identify more easily with a scenario such as Scenario 10 in which the paddy area is reduced by 50% and the agricultural area by 20%, in accordance with the policy of limiting the area of high water-demanding crops and dissuading farmers from cultivating the marginal lands. Although maximum attainable income in S10 is about 5% higher than in S2, farmers prefer to maintain the current paddy area. This conflicting situation is compounded by the fact that communication between small-scale farmers and the agricultural department is relatively weak (Figure 5.6). Another example is the conflict between Scenarios 1 and 12. In this case, farmers prefer S1, while the Water Users Association's objective is minimising water use, i.e. encourage cultivation of crops that are relatively less water-demanding and thus its preference is S12. Compared to S1, income in S12 is 22% lower, while water use is 36% lower, and there is a significant reduction in biocide use. Therefore, analysing the scenarios generated with the MGLP model in the context of the SCM, can be useful to gain insight in the interactions among stakeholders in the system and take curative measures if required for improved communication. While the MGLP model considers the bio-economics of the land use system, the SCM describes the social aspects of the system, which is critical for successful implementation of the MGLP model.

5.5 Discussion and Conclusions

The MGLP model is useful as a negotiation support tool in agricultural policy formulation. A modest risk-avoiding method can be incorporated in the model. As paddy cultivation is mainly water availability-driven, a delayed, inadequate or failed monsoon is an important risk factor to be considered. In the MGLP model, a scenario of for instance 0% or 10% paddy area (depending on how much area has already been planted before the situation of the monsoon is clear) can also be generated for discussion by the agricultural planners, based

on their local experience, crop calendars and discussions with the farmers. This could assist them in comparing alternative scenarios.

| | Marginal / small scale farmer | Large scale farmer | Agric Dept | Rural Development Agency | Water Users Association | Agric Research Station / Scientists | Extension Service |
|-------------------------------------|-------------------------------|--------------------|------------|--------------------------|-------------------------|-------------------------------------|-------------------|
| Marginal / small scale farmer | - | ● | ● | ● | ● | ● | ● |
| Large scale farmer | ● | - | ● | ● | ● | ● | ● |
| Agric Dept | ● | ● | - | ● | ● | ● | ● |
| Rural Development Agency | ● | ● | ● | - | ● | ● | ● |
| Water Users Association | ● | ● | ● | ● | - | ● | ● |
| Agric Research Station / Scientists | ● | ● | ● | ● | ● | - | ● |
| Extension Service | ● | ● | ● | ● | ● | ● | - |

Figure 5.6. Stakeholder Communication Matrix

The study also brought out the significance of developing a SCM as a means of understanding the social dynamics of the system. The conclusion is that while the MGLP model is a useful tool to model bio-economics of the land use system, the social context in which it is implemented determines the relevance of the model results. The SCM is a relevant tool to describe the interrelations among stakeholders with communication as an indicator. The MGLP scenarios analysed in the context of SCM provide insight into the bottlenecks obstructing negotiation and successful application of the model. The workshop and the interactions with the stakeholders provided an opportunity to interact with the users on the basis of the results of the MGLP model, and to discern the usefulness and relevance of the study. The scenarios generated with the MGLP model and the examples discussed in the context of the SCM serve as examples to demonstrate the model and the method to integrate both approaches. The aim of this study was not to generate land use planning options for the study

area, but to develop tools for the district level planners to negotiate with the various stakeholders on the options and their consequences. Eventually, the users take the final decision on land use, based on their socio-economic context and the policy instruments that the administration offers in support of its initiatives. Moreover, the model is applied to perform analyses at regional scale and farmers take land use decisions at farm level. Therefore, studies at a farm scale would be required to investigate farm level possibilities in terms of opportunities and constraints.

The approach developed in this study is intended to support district level planners (at a regional to sub-regional level) and as an input in their policy formulation rather than for operational decision-making.

In the next chapter, we demonstrate modelling farmers' knowledge of land agriculture suitability classification. This chapter builds on previous chapters on integrating the hard and soft systems (characteristics of the land and knowledge and perceptions of farmers of its suitability for agriculture).

References

- Chief Planning Officer (CPO), 1995 & 2001. Handbook of Statistics- Nizamabad District, Nizamabad, Andhra Pradesh, India.
- Chuvieco, E., 1993. Integration of linear programming and GIS for land use modelling. *International Journal of GIS* 7, 71-83.
- Clayton, B.D., Dent, D., Dubois, O., 2003. Rural Planning in Developing Countries: Supporting Natural Resource Management and Sustainable Livelihoods. IIED, Earth Scan Publications Ltd. London. P 226.
- De Wit, C.T., van Keulen, H., Seligman, N.G., Spharim, I., 1988. Application of Interactive Multiple Goal Techniques for Analysis and Planning of Regional Agricultural Development. *Agricultural Systems* 26, 211-230.
- Dogliotti, S., 2003. Exploring options for sustainable development of vegetable farms in South Uruguay. PhD Thesis. Wageningen University, Wageningen, The Netherlands. 145 pp.
- FAO, 2002. Smallholder Farmers in India: Food Security and Agricultural Policy. Food and Agricultural Organisation, FAO Regional Office for Asia and the Pacific, Bangkok, Thailand
- GAMS, 1998. GAMS Development Corporation. 1217 Potomac Street, N.W., Washington, DC 20007, USA.

- Ganzert, C., 1995. Konzeption für eine ökologische Agrarlandschaftsforschung. *Berichte der ANL, Beih. 12* (Festschrift zum 70. Geburtstag von Prof. Dr. Wolfgang Haber), 51-64.
- Grimble, R., Wellard, K., 1997. Stakeholder Methodologies in Natural Resource Management: a Review of Principles, Contexts, Experiences and Opportunities. *Agricultural Systems* 55, 173-193.
- Harmsen, K., Nidumolu, U.B., 2002. Land use Planning for Sustainable Development in South Asia: An example from India. In: Navalgubd, R.R., Nayak, S.R., Sudarshana, R., Ravindran, S. (Eds.), *Resource and Environmental Monitoring. ISPRS & SIS* 34, 1467-1475..
- Hengsdijk, H., van Ittersum, M.K., 2002. A goal-oriented approach to identify and engineer land use systems. *Agricultural Systems* 71, 231-247.
- Huizing, H., Bronsveld, K., 1994. Interactive multiple-goal analysis for land use planning. *ITC Journal* 4, 366-373.
- Holling, C.S., Berkes, F., Folke, C., 1998. Science, sustainability and resource management. In: Berkes, F., Folke, C., Colding, J. (Eds.), *Linking Social and Ecological Systems: Management Practices and Social Mechanisms for Building Resilience*. Cambridge University Press, Cambridge. pp. 342-362.
- Kaur, R., Srivastava, R., Betne, R., Mishra, K., Dutta, D., 2004. Integration of linear programming and a watershed-scale hydrologic model for proposing an optimised land use plan and assessing its impact on soil conservation – A case study of the Nagwan watershed in the Hazaribagh district of Jharkand, India. *International Journal of GIS* 18, 73-98.
- Lu, C.H., van Ittersum, M.K., Rabbinge, R., 2004. A scenario exploration of strategic land use options for the Loess Plateau in northern China. *Agricultural Systems* 79, 145-170.
- Lu, J., Zhaoqian, W., Penning de Vries, F.W.T., 2002. Application of interactive multiple goal programming for red soil watershed development: a case study of Qingshishan watershed. *Agricultural Systems* 73, 313-324.
- Nidumolu, U.B., Alanga, P., 2001. Natural Resources Information Generation for planning: An Indian Example. *GIM International*. 15, 77-79.
- NRSA, 1995. *IMSD Technical Guidelines*. National Remote Sensing Agency. Hyderabad, India.
- Rabbinge, R., van Latesteijn, H.C., 1992. Long-Term options for land use in the European Community. *Agricultural Systems* 40, 195-210.
- Ramirez, R., 1999. Stakeholder analysis and conflict management. In: Buckles, D. (Ed.). *Conflict and Collaboration in Natural Resource Management*. IDRC/World Bank Institute, Ottawa and Washington D.C. 126 pp.

- Röling, N., 1994. Platforms for decision making about eco-systems. In: Fresco, L.O., Stroosnijder, L., Bouma J., van Keulen, H (Eds.) *The Future of the Land. Mobilising and Integrating Knowledge for Land Use Options*. John Wiley, Chichester. pp. 386-393.
- Romero, C., Rehman, T., 1989. Multiple criteria analysis for agricultural decisions. Elsevier Science, Amsterdam. 257 pp.
- Sarkar, R.A., Quaddus, M.A., 2002. Modelling a nationwide crop planning problem using a multiple criteria decision making tool. *Computers Indust. Eng.* 42, 541-553.
- Struif Bontkes, T., van Keulen, H., 2003. Modelling the dynamics of agricultural development at farm and regional level. *Agric. Syst.* 76, 379-396.
- Sujith Kumar, S., Vasisht, A.K., Hoanh, C.T., Aggarwal, P.K., Kalra, N., 2001. Linking socio-economics to the biophysical evaluation: The MGLP model. In: Aggarwal, P.K., Roetter, R.P., Kalra, N., van Keulen, H., Hoanh, C.T., van Laar, H.H. (Eds.). *Land use analysis and planning for sustainable food security: with an illustration for the state of Haryana, India*. New Delhi: Indian Agricultural Research Institute; Los Baños: International Rice Research Institute; Wageningen: Wageningen University and Research Centre. 167 pp.
- Van Ittersum, M.K., Rabbinge, R., van Latesteijn, H.C., 1998. Exploratory Land Use Studies and their role in Strategic Policy Making. *Agricultural Systems* 58, 309-330.
- Van Keulen, H., Kuyvenhoven, A., Ruben, R., 1998. Sustainable Land Use and Food Security in Developing Countries: DLV's Approach to Policy Support. *Agricultural Systems* 58, 285-307.
- Van Keulen, H., van Ittersum, M.K., Roetter, R.P., de Ridder, N. and Hoanh, C.T., 2002. New approaches to support development of Sustainable Land Use Systems. In: *International Symposium on Sustaining Food Security and Managing Natural Resources in Southeast Asia - Challenges for the 21st Century*. Chiang Mai, Thailand, January 8-11, 2002. CD-Rom.
- Van Kooten, G.C., 1993. *Land resources economics and sustainable development*. UBC Press, Vancouver, BC.
- Zander, P., Kächele, H., 1999. Modelling multiple objectives of land use for sustainable development. *Agricultural Systems* 59, 311-325.

Appendix 5.1

Mathematics of Pitlam Model

Constraints

Land

$$\sum_c A_{c,lt} \leq TLan \quad (1)$$

A= Area allotted to crop c , $TLan$ =Total Land available
(for all valid c , lt combinations)

Labour

$$\sum_{c,lt} Lc \cdot A_c \leq TLab \quad (2)$$

(for all valid c , lt combinations)

A= Area allotted to crop c , L = Labour man-days required per crop per hectare,
 $TLab$ =Total labour available

Profit Constraint

$$\sum_{c,lt} (P_c \cdot Y_{c,lt} \cdot A_{c,lt}) - \sum_{c,lt} (Lc_c \cdot A_{c,lt} + Fc_c \cdot A_{c,lt} + Bc_c \cdot A_{c,lt} + Oc_c \cdot A_{c,lt}) > 0 \quad (3)$$

(for all valid c , lt combinations)

P =price per crop, Y =Yield per hectare, Lc = Labour cost per hectare, Fc =Fertiliser costs per hectare, Bc = Biocide costs per hectare, Oc =Other costs per hectare

Cost constraint

$$\sum_{c,lt} (Lc_c \cdot A_{c,lt} + Fc_c \cdot A_{c,lt} + Bc_c \cdot A_{c,lt} + Oc_c \cdot A_{c,lt}) \leq TC \quad (4)$$

(for all valid c , lt combinations)

Lc = Labour cost per hectare, Fc =Fertiliser costs per hectare, Bc = Biocide costs per hectare, Oc =Other costs per hectare, TC =Total Capital available

Water constraint

$$\sum_{c,lt} (Wc \cdot A_{c,lt}) \leq TW \quad (5)$$

(for all c)

Wc = Water required per crop per hectare in mm, A_c = Area allotted to crop c , TW =Total Water available; Note: All costs are in Indian rupees (1 US\$ = Rs 45 (approx))

Objective Functions

Profit

Max

P=

$$\left\{ \sum_{c,lt} (P_c \cdot Y_{c,lt} \cdot A_{c,lt}) - \sum_{c,lt} (L_c \cdot A_{c,lt}) - \sum_{c,lt} (F_c \cdot A_{c,lt}) - \sum_{c,lt} (B_c \cdot A_{c,lt}) - \sum_{c,lt} (O_c \cdot A_{c,lt}) \right\}$$

(for all valid c, lt combinations) (6)

Labour

$$\text{Max } L = \sum_{c,lt} (L_c \cdot A_{c,lt}) \quad (7)$$

(for all valid c, lt combinations)

Water-used

$$\text{Min } W = \sum_{c,lt} (W_c \cdot A_{c,lt}) \quad (8)$$

(for all valid c, lt combinations)

Costs

$$\text{Min } C = \sum_{c,lt} (L_c \cdot A_{c,lt} + F_c \cdot A_{c,lt} + B_c \cdot A_{c,lt} + O_c \cdot A_{c,lt}) \quad (9)$$

(for all valid c, lt combinations)

Fertiliser

$$\text{Min } F = \sum_{c,lt} (F_c \cdot A_{c,lt}) \quad (10)$$

(for all valid c, lt combinations)

Biocide

$$\text{Min } B = \sum_{c,lt} (B_c \cdot A_{c,lt}) \quad (11)$$

(for all valid c, lt combinations)

Appendix 5.2

Pitlam Model Formulation in GAMS

```

SETS
c          Crops      /Paddy, Jowar,Bajra,Sugarcane, Cotton, Greengram,
                    Blackgram, Groundnut /
LT         LandType   Irrigated or NotIrrigated /Kirr, Knirr, Rirr, Rnirr/
LU(c,lt)   /Paddy.Kirr,Paddy.Rirr, Sugarcane.Kirr, Cotton.Knirr,
                    Paddy.Knirr, Jowar.Knirr, Jowar.Rnirr, Bajra.Knirr,
                    Bajra.Rnirr, Greengram.Rnirr, Blackgram.Rnirr, Groundnut.Kirr/
LU_Paddy(c,lt) /Paddy.Kirr, Paddy.Knirr, Paddy.Rirr/
LU_Cotton(c,lt) /Cotton.Knirr/
LU_Jowar(c,lt)  /Jowar.Knirr, Jowar.Rnirr/
LU_Bajra(c,lt)  /Bajra.Knirr, Bajra.Rnirr/
LU_Greengram(c,lt) /Greengram.Knirr, Greengram.Rnirr/
LU_Blackgram(c,lt) /Blackgram.Knirr, Blackgram.Rnirr/
LU_Groundnut(c,lt) /Groundnut.Kirr/
;

$ontext
Kirr, Rirr: Kharif irrigated and Rabi irrigated resp; Knirr, Rnirr:
Kharif non-irrigated and Rabi non-irrigated resp
$offtext

PARAMETERS
Labor(c)      Amount of Labour required (labour days needed per ha)/
               Paddy = 112, Jowar = 50,
               Bajra = 50,Sugarcane = 230, Cotton = 92, Greengram = 40,
               Blackgram = 34, Groundnut = 78/
Waterreq(c)   Water requirements per ha in mm /
               Paddy = 540, Jowar = 60,
               Bajra = 60,Sugarcane = 512, Cotton = 306, Greengram = 50,
               Blackgram = 45, Groundnut = 100/
Price(c)      Price of crops in Rupees per ton /
               Paddy = 4050, Jowar = 5080,
               Bajra = 3890, Sugarcane = 560,Cotton = 20610,Greengram = 12960,
               Blackgram = 14400, Groundnut = 10440/
Fertiliser(c) Fertiliser use in kgs per crop per ha/
               Paddy = 165, Jowar = 44,
               Bajra = 44, Sugarcane = 219, Cotton = 180, Greengram = 30,
               Blackgram = 35, Groundnut = 80/
Land(lt)      /Kirr = 2884, Knirr = 3286,Rirr = 2399, Rnirr = 1545/
Totwater(lt)  Water available per ha
               /Kirr = 1203, Rirr = 1203, Knirr = 826, Rnirr = 600/

* Costs of production per crop per ha

LabC(c)       Labour(includes human draught and machine labour)costs per crop per ha/
               Paddy = 2598, Jowar = 638,
               Bajra = 2365, Sugarcane = 20410, Cotton = 2393, Greengram = 1900,
               Blackgram = 1700, Groundnut = 2300/
FertiC(c)     Fertiliser manure costs per crop per ha/
               Paddy = 970, Jowar = 344,
               Bajra = 500, Sugarcane = 6625, Cotton = 3387, Greengram = 300,
               Blackgram = 550, Groundnut = 850/
BioC(c)       Biocide costs per crop per ha/
               Paddy = 364, Jowar = 174,
               Bajra = 100, Sugarcane = 1540, Cotton = 7637, Greengram =500 ,
               Blackgram = 600, Groundnut = 500/
OtherC(c)     Other costs per crop per ha/
               Paddy = 3373, Jowar = 1815,
               Bajra = 100, Sugarcane = 2389, Cotton = 4311, Greengram = 3100,
               Blackgram = 2963, Groundnut = 8309/
;
Scalars
lab          Total labour available (labour days per year) /1242300/
profit      /20858695/
Money       Total costs of agric /83434781/
WaterLimit  Total amount of water that can be used (mm) /2908601/
WaterLimitIrr mm /1500/
PaddyLand   Minimum area allocated to paddy /3793/
CottonLand  Minimum area allocated to Cotton /529/
JowarLand   Minimum area allocated to Jowar /1603/

```

```

        BajraLand      Minimum area allocated to Bajra      /150/
        Greengramland  Minimum area allocated to Greengram    /1059/
        Blackgramland  Minimum area allocated to Blackgram      /1059/
        Groundnutland  Minimum area allocated to Groundnut     /727/
;
;
-----
*declaration of variables
-----
VARIABLES
vXcrop(c,lt)      cropping activity      (hectares)
;

Free Variables
vProfit          profit per crop per ha (rupees)
vLabor
vWater(lt)
vcosts
vferti
vbicide
vWaterUsed
;

POSITIVE VARIABLES
vXcrop
;

* Yield - tons / ha

table Yield(c,lt)
      Kirr      Knirr      Rirr      Rnirr
Paddy      2.126      1.5      2.126      0
Jowar       0      0.743      0      0.743
Bajra       0      0.422      0      0.422
Sugarcane   73.64      0      73.64      0
Cotton      0      1.2      0      1.2
Greengram   0      0.793      0      0.793
Blackgram   0      0.565      0      0.565
Groundnut   1.47      0      1.47      0
;

Equations
eLabor
ecLabor
ecLand(lt)
ecWaterNeededforaCrop(c,lt)
*eWater(lt)
eWaterUsed
ecWaterLimit
eProfit
ecProfit
ecCosts
eCosts
eferti
ebicide
*ecpaddy
*ecjowar
*ecbajra
*ecCotton
*ecGreengram
*ecBlackgram
*ecGroundnut
;

-----
* Constraints
-----

*Land constraint - Total land used for agriculture should be
*less than or equal to the Total land available

ecland(lt)..
SUM((c),vXcrop(c,lt)$lu(c,lt)) =L= Land(lt);
* Labour constraint - Total labour used for agriculture should be

```

Integrating MGLP and SCM

```
*less than or equal to the Total labour available
ecLabor..
SUM((c,lt)$lu(c,lt), vXcrop(c,lt) * labor(c)) =L= Lab;

*Minimum land that is allotted to paddy cultivation
$ontext
ecpaddy..
SUM((c,lt)$lu_paddy(c,lt), vXcrop(c,lt))=e= paddyland;

ecCotton..
SUM((c,lt)$lu_cotton(c,lt), vXcrop(c,lt))=g= Cottonland;
ecjowar..
SUM((c,lt)$lu_jowar(c,lt), vXcrop(c,lt))=g= jowarland;
ecbajra..
SUM((c,lt)$lu_bajra(c,lt), vXcrop(c,lt))=g= bajraland;
ecGreengram..
SUM((c,lt)$lu_greengram(c,lt), vXcrop(c,lt))=g= Greengramland;
ecBlackgram..
SUM((c,lt)$lu_blackgram(c,lt), vXcrop(c,lt))=g= Blackgramland;
ecGroundnut..
SUM((c,lt)$lu_groundnut(c,lt), vXcrop(c,lt))=g= Groundnutland;

$offtext

*Profit is price minus costs should always be greater than 0
ecProfit..
SUM((c,lt)$lu(c,lt),price(c) * Yield(c,lt)* vXcrop(c,lt))
- SUM((c,lt)$lu(c,lt),LabC(c) * vXcrop(c,lt))
- SUM((c,lt)$lu(c,lt),FertiC(c) * vXcrop(c,lt))
- SUM((c,lt)$lu(c,lt),BioC(c) * vXcrop(c,lt))
- SUM((c,lt)$lu(c,lt),OtherC(c) * vXcrop(c,lt))
=g=0;

* Costs should always be less than or equal to the total money available
ecCosts..
SUM((c,lt)$lu(c,lt),LabC(c) * vXcrop(c,lt))
+ SUM((c,lt)$lu(c,lt),FertiC(c) * vXcrop(c,lt))
+ SUM((c,lt)$lu(c,lt),BioC(c) * vXcrop(c,lt))
+ SUM((c,lt)$lu(c,lt),OtherC(c) * vXcrop(c,lt))
=L=Money;

* Water used per crop should be less than or equal to total water available
ecWaterNeededforaCrop(c,lt)..
Waterreq(c) =l= totwater(lt);

ecWaterLimit..
SUM((c,lt)$lu(c,lt), waterreq(c) * vXcrop(c,lt))=l= Waterlimit;
*-----
* Objectives
*-----

eProfit..
vProfit =e= SUM((c,lt)$lu(c,lt),price(c) * Yield(c,lt) * vXcrop(c,lt))
- SUM((c,lt)$lu(c,lt),LabC(c)*vXcrop(c,lt))
- SUM((c,lt)$lu(c,lt),FertiC(c) * vXcrop(c,lt))
- SUM((c,lt)$lu(c,lt),BioC(c) * vXcrop(c,lt))
- SUM((c,lt)$lu(c,lt),OtherC(c) * vXcrop(c,lt))
;

eLabor..
vLabor =e= SUM((c,lt)$lu(c,lt), vXcrop(c,lt) * labor(c));

*eWater(lt)..
* vWater(lt) =l= - SUM((c)$lu(c,lt),Waterreq(c) * vXcrop(c,lt))+ SUM((c),
* totwater(lt) * vXCrop(c,lt));

eWaterUsed..
vWaterUsed =l= SUM((c,lt)$lu(c,lt), vXcrop(c,lt)* waterreq(c));

eferti..
vferti =e= SUM((c,lt)$lu(c,lt),Fertiliser(c) * vXcrop(c,lt));

ebiocide..
vbiocide =e= SUM((c,lt)$lu(c,lt),BioC(c) * vXcrop(c,lt));
```

```
eCosts..
vCosts =E= SUM((c,lt)$lu(c,lt),LabC(c)*vXcrop(c,lt))
+ SUM((c,lt)$lu(c,lt),FertiC(c)* vXcrop(c,lt))
+ SUM((c,lt)$lu(c,lt),BioC(c)* vXcrop(c,lt))
+ SUM((c,lt)$lu(c,lt),OtherC(c)* vXcrop(c,lt));
```

```
*-----
MODEL Modell /all/;
*-----
SOLVE Modell USING LP Maximise vlabor;
*-----
```

Chapter 6

Fuzzy Modelling of Farmers' Knowledge for Land Suitability Classification

Abstract

In a case study, we demonstrate fuzzy modelling of farmers' knowledge (FK) for agricultural land suitability classification using GIS. Capture of FK was through rapid rural participatory approach. The farmer respondents consider, in order of decreasing importance, cropping season, soil colour, soil texture, soil depth and slope as factors of suitability of their land for certain crops. Multi-class fuzzy sets using S-membership functions were generated for soil texture, soil depth and slope because of correlation or equivalence between farmers' definitions and scientific classifications of such land characteristics. In contrast, binary fuzzy relations, which are also fuzzy sets, were generated for cropping season and soil colour because farmers' perceptions of such land characteristics are intrinsically binary. Despite variations in individual farmers' perceptions of land suitability, 12 unique FK rules for classifying land suitability were defined by hierarchical grouping of such different perceptions based on decreasing importance of factors. The FK rules form inference engines in combining fuzzy factor maps using appropriate fuzzy operators to create agricultural land suitability maps. Suitability maps resulting from application of Fuzzy AND and Fuzzy OR operators were found consistent with the FK rules. The FK-based suitability maps indicate either agreement or conflict with a Land Resource Development Plan for the case study area. Results of the study indicate usefulness of fuzzy modelling in FK-based classification of agricultural land suitability, which could provide useful information for optimum land-use planning.

Keywords: agricultural land suitability; land-use planning; farmers' knowledge; modelling; fuzzy sets; GIS

Based on: Rodrigo S. Sicat, Emmanuel John M. Carranza, Uday Bhaskar Nidumolu. 2004. Fuzzy Modelling of Farmers' Knowledge for Land Suitability Classification. (*In Press: Agricultural Systems*)

6.1 Introduction

Agricultural land suitability classification based on indigenous knowledge is vital to land-use planning - the systematic assessment of land and water potential, alternatives for land use and socio-economic conditions in order to select and put into practice those land uses that will best meet the needs of the people while safeguarding resources for the future (FAO, 1993). Authorities in top levels of government organizations usually develop land-use plans exclusive of indigenous knowledge. This non-participatory approach, however, commonly results in land-use plans that are poorly adopted by certain communities because such plans are often not agreeable with the desires of local people (FAO, 1997). On the other hand, farmers usually make their own agricultural land suitability classifications, which could also be socio-economically non-optimal due to a dichotomy of interests between farmers and the community to which they belong. Optimum land-use planning, therefore, should strive to identify improved and sustainable land-uses, through integration of the objectives and knowledge of the community and those of individual farmers.

It is generally agreed that the terms farmers' knowledge, indigenous knowledge, traditional knowledge, local knowledge, community knowledge, rural peoples' knowledge and indigenous technical knowledge all pertain to knowledge belonging to local people. While certain distinctions can be made, these terms often refer to the same thing (Roach, 1994; Mathias, 1995). In this paper, we use the term farmers' knowledge (FK) because it refers specifically to the knowledge of farmers in our study area, whether this knowledge is traditional, modern or mixed traditional-modern knowledge.

It has been shown that FK is important to agricultural land suitability classification (e.g., Habarurema and Steiner, 1997; Steiner, 1998; Ryder, 2003). It is even more useful when FK is integrated with scientific methods of land evaluation, which can be achieved effectively through application of geographic information systems or GIS (Lawas and Luning, 1996; Wandahwa and Van Ranst, 1996; Messing and Fagerstrom, 2001; Zurayk et al., 2001; Gonzalez, 2002; Cools et al., 2003; Oudwater and Martin, 2003). Common to previous works is the subjective or qualitative modelling of FK. However, FK is invariably portrayed as linguistic variables that are inherently vague or fuzzy, which could be inadequately modelled by subjective or qualitative approaches. A more adequate modelling of FK for agricultural land suitability classification

requires approaches capable of using vague or fuzzy concepts where a precise membership or non-membership in a land suitability class based on FK may be impossible or impractical to define.

Modelling of vague concepts is feasible by application of the theory of fuzzy sets (Zadeh, 1965). Fuzzy modelling of spatial data based on theoretical knowledge has been demonstrated to be useful in various GIS-based studies of land suitability classification (e.g. Van Ranst et al., 1996; Groenemans et al., 1997; Kollias and Kalivas, 1998; Nisar Ahamed et al., 2000; Triantafilis et al., 2001; Liu and Samal, 2002; Malczewski, 2002; Ceballos-Silva and López-Blanco, 2003). In addition, Beek (2000) avers that FK justifies fuzzy modeling in natural resource studies, in which certain properties are difficult to model, data are insufficient for statistical analysis or when relations between indicator variables are not clearly known. However, fuzzy modelling of spatial data based on FK to classify agricultural land suitability has not been reported yet.

In this paper, we demonstrate FK-based fuzzy modelling for agricultural land suitability classification using case spatial data sets from India. Firstly, we describe briefly theoretical concepts behind fuzzy sets, membership functions and operators. Secondly, we describe the case study area where local people, particularly farmers, have poorly adopted land-use plans developed through non-participatory approaches. Finally, we describe the knowledge bases and the spatial data captured into a GIS and the procedures followed for FK-based modelling of agricultural land suitability.

6.2 Fuzzy modelling

In classical set theory, membership in a set or a class is crisp and defined only as either non-complete (=0) or complete (=1). In fuzzy set theory, membership in a set or a class can range from non-complete (=0) to complete (=1) (Zadeh, 1965). Fuzzy sets are thus useful to classify attributes according to vague concepts of membership (e.g., McBratney and Odeh, 1997; Lawry, 2001; Carranza and Hale, 2001).

A fuzzy set X is a presupposed finite set (or space) of attributes. A fuzzy subset A of X is defined by a function, μ_A , in ordered pairs $A = \{x, \mu_A(x)\}$ for each $x \in X$. The relation $\mu_A(x)$ is a fuzzy membership function (FMF), which defines the grade of membership of x in A ; $x \in X$ indicates that x is in X . For all

A , $\mu_A(x)$ is a value in the unit interval $[0,1]$ (i.e. a value in a set of all real numbers r with $0 \leq r \leq 1$). A grade of zero (0) means that an attribute has complete non-membership in a fuzzy set while a grade of one (1) means that an attribute has complete membership in a fuzzy set and grades between 0 and 1 mean partial membership in a fuzzy set. Grades of membership are usually modelled by FMFs, which need not be linear or even continuous; indeed, many interesting fuzzy sets have extremely nonlinear FMFs (Zimmerman, 1991). Grades of membership in a fuzzy set always relate to a certain proposition. In this case, the FK-based proposition is: "This piece of land, based on a certain land characteristic, is suitable for agriculture".

Fuzzy membership grades can be determined using S-membership functions, which are appropriate and robust for linguistic variables (e.g., FK). A S-membership function for x attributes can be defined as (Robinson, 2003):

$$S(x; \alpha, \beta, \gamma) = \begin{cases} 0; & x \in [-\infty, \alpha] \\ 2[(x - \alpha) / (\gamma - \alpha)]^2; & x \in [\alpha, \beta] \\ 1 - 2[(x - \beta) / (\gamma - \alpha)]^2; & x \in [\beta, \gamma] \\ 1; & x \in [\gamma, +\infty] \end{cases} \quad \text{or (1)}$$

$$S(x; \alpha, \beta, \gamma) = \begin{cases} 1; & x \in [-\infty, \alpha] \\ 1 - 2[(x - \alpha) / (\gamma - \alpha)]^2; & x \in [\alpha, \beta] \\ 2[(x - \beta) / (\gamma - \alpha)]^2; & x \in [\beta, \gamma] \\ 0; & x \in [\gamma, +\infty] \end{cases} \quad (2)$$

Equations 1 and 2 represent, respectively, increasing and decreasing FMFs (i.e. fuzzy values) for x attributes (e.g., soil depth) representing a factor S ; α and γ are lower or upper limits of x attributes, and β is $(\alpha + \gamma) / 2$. In applying Equations 1 and 2 based on FK, the semantic import (SI) approach (McBratney and Odeh, 1997) can be employed to define multi-classes or fuzzy subsets based on conventionally imposed definitions or on experience (i.e. FK in this case). The SI approach can be seen as an extension of Boolean approaches and sensible comparisons can be made with strictly defined Boolean classes (Burrough et al., 1992). To illustrate how Equations 1 and 2 can be applied, suppose an area with soil depths (i.e. S) varying from 0 to 200 cm and suppose further that the soil depth data (i.e. x) has to be modelled into fuzzy subsets of 'shallow', 'deep' and 'very deep' soils according to a certain proposition. Fuzzy subset 'shallow' soils can be modelled by a decreasing FMF S-curve using Equation 2 with $\alpha=0$ cm and $\gamma=100$ cm (Figure 6.1). Fuzzy subset of 'very deep' soils can be modelled by an increasing FMF S-curve using Equation 1 with $\alpha=100$ cm and $\gamma=200$ cm.

Fuzzy subset 'deep' soils can be modelled by an FMF with increasing and decreasing S -curves; the increasing S -curve can be modelled using Equation 1 with $\alpha=0$ cm and $\gamma=100$ cm while the decreasing S -curve can be modelled using Equation 2 with $\alpha=100$ cm and $\gamma=200$ cm. The fuzzy subsets of 'shallow' and 'very deep' soils have asymmetrical FMFs while the fuzzy subset of 'deep' soils has a symmetrical FMF, representing a normal and convex FMF. Thus, for example, soils with depths of 100 cm have complete membership in the 'deep' soil fuzzy subset and have grades of membership of 1 whereas soils with depths of $0 \leq x < 100$ cm or $100 < x \leq 200$ cm have partial membership grades in this fuzzy subset. Fuzzy sets can thus overlap and the attribute value at the point where grades of membership equal 0.5 is called the 'crossover point', which illustrates that sets in the real world do not necessarily have sharply defined limits and that a continuum of attributes is not always classifiable with rigidly defined limits.

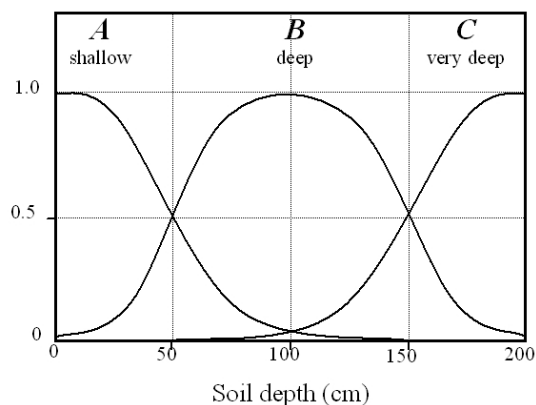

Figure 6.1. Fuzzy membership functions fitted to fuzzy subsets of (a) 'shallow' soils, (b) 'deep' soils and (c) 'very deep' soils (adapted from McBratney and Odeh, 1997).

As in classical set theory, set-theoretic operations can be performed to integrate fuzzy sets, including equality, containment, union and intersection, all of which have meanings analogous to their crisp set equivalents. Hence, an integrated fuzzy land suitability index can be derived using appropriate fuzzy operators (e.g., Bonham-Carter, 1994; Carranza and Hale, 2001), weight factors (Tang, 1993) and joint membership functions (Davidson et al., 1994). Typically, fuzzy modelling of spatial data involves three main feedforward stages: (1) fuzzification; (2) logical inference procedures performed with fuzzy set operations; and (3) defuzzification (Figure 6.2). Fuzzification, which can be

knowledge-driven or data-driven, involves generation of FMFs for input categorical or numeric data. Inference procedures involve implementation of parallel and/or serial rules that sequentially combine fuzzy sets through fuzzy set operators into a synthesized fuzzy set. There are no general guidelines for designing a logical inference procedure except that as much as possible it should simulate the human decision-making process. Defuzzification involves transformation of a synthesized fuzzy set back to a crisp set, which expresses the result of modelling. Defuzzification can make use of a subjectively- or objectively-defined threshold fuzzy value. Hellendoorn and Thomas (1993) describe a number of criteria that an ideal defuzzification procedure should satisfy. The most important criterion is that a small change in inputs of a fuzzy model should not cause a significant change in output.

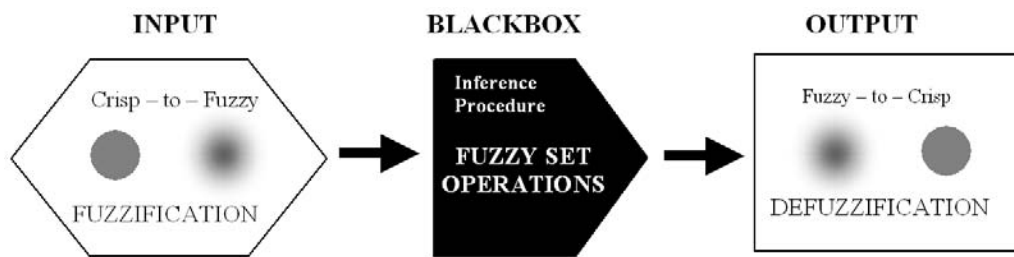

Figure 6.2. Main stages in fuzzy modeling.

6.3 The case study area

Agricultural land suitability classification through FK-based (i.e. knowledge-driven) fuzzy modelling of spatial data was tested in an area in Nizamabad District of Andhra Pradesh State in India.

6.3.1 Background

In India, a GIS-based land-use planning project called the 'Integrated Mission for Sustainable Development' generates, analyzes and integrates 1:50,000 scale natural resource thematic data, together with satellite remote sensing data, to create land resources development plans (LRDP) for alternate land-uses based on resource potential, groundwater exploration and recharge, surface water harvesting and soil conservation. The LRDPs were to be implemented by district level resource managers. However, such LRDPs were poorly adopted by several local communities (Harmsen and Nidumolu, 2002) because such

plans (a) failed to analyze the complete array of local circumstances and to diagnose the best points of local intervention and, consequently, (b) do not coincide with land-uses desired by primary stakeholders, particularly the local farmers. The Nizamabad District (Andhra Pradesh State, India) is one of the districts for which an LRDP was created. In this district, a suitable case area was found (i.e. soil database, digital elevation model, and a land-use map are available) for FK-based modelling of land suitability for comparison with the LRDP.

6.3.2 Geography and agricultural practices

The study area lies in the western part of Nizamabad District (Figure 6.3). It consists 220 villages belonging to six mandals (or administrative sub-divisions in a district) with a total area of about 1300 km², about 70-75% of which is used for agricultural purposes. Each village has its own Water Users Association (WUA), who, with the aid of the Mandal agriculture officer, determines which crops will be sown based on amount of available water. The Irrigation Office provides this information to the Mandal Office, which, in turn, provides information to the villages.

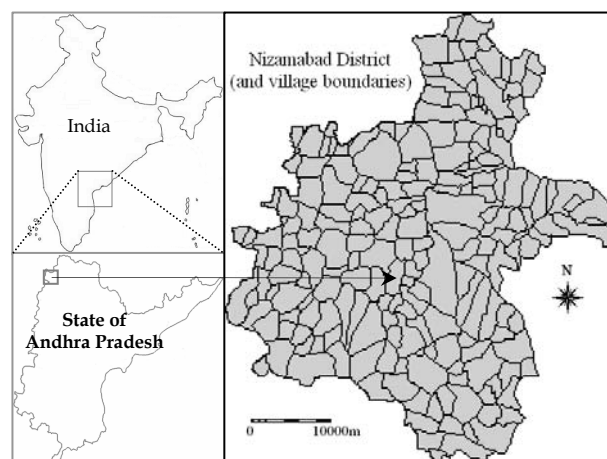

Figure 6.3. Location of study area.

Generally, agricultural practices do not greatly vary from village to village although, socio-economically, the peasantry ranges from affluent farmers to subsistence farmers. Between these extreme groups, various intensities of agriculture are practiced. A major consideration is availability of and

accessibility to water. Financially-capable farmers have electricity-driven irrigation systems. In most of the villages, however, electricity is not always available throughout a day.

There are two main cropping seasons (refer to land cover classes mapped) when rain and groundwater are available: (1) *Kharif* (June to October); (2) *Rabi* (November to March). '*Kharif+Rabi*' is the double cropped land cover class, areas where crops are grown both in Kharif and Rabi seasons. The summer cropping season is called *Zaid* (April to June) and depends on groundwater. In some villages, however, local farmers do not follow such distinct cropping seasons but have their own classification of cropping seasons. Whatever the cropping season, agricultural practice is either by mono-cropping, by multiple-cropping or by rotational cropping. The present trend is intensive rotational multiple-cropping in a year; however, relay-cropping (i.e. one crop sown in a standing crop) also occurs.

Around 40% of the gross cropped area is not assured of irrigation and such areas are categorized as 'rain-fed drylands'. Agriculture in these 'rain-fed drylands' is characterized by (a) lack of assured water supply for irrigation, (b) lack of technologies and cropping systems suited to dryland conditions, (c) poor resources and inadequate extension/support services, and (d) low productivity. Agriculture in these 'rain-fed drylands' are generally confined to relatively well-irrigated areas, where the traditional practice of subsistence multiple-cropping is shifting to commercial mono-cropping, largely because farmers feel it is the way to 'prosperity'. However, application of high doses of fertilizers and chemicals needed by certain crops hastens land degradation. Moreover, farmers with small land holdings tend to maximize utilization of their small plots in an unsustainable manner, thus depleting the full potential of the land for succeeding cropping activities. It is therefore not surprising that the 'rain-fed drylands' are among the least developed and poorest in the region.

6.3.3 Farmers' knowledge of land suitability

Farmers' knowledge and field data were gathered during a 3-week fieldwork in September-October 2002. The FK was gathered through interviews using a semi-structured questionnaire (Appendix A). The farmers interviewed generally belong to 'rural Telangana farmers' who have common traits, traditions and culture with respect to agriculture. The interviews were limited to a rapid rural participatory approach and not based on village immersion

methodologies (e.g., Lawas and Luning, 1996). The interviews were carried out in 26 randomly chosen localities representing zones that were classified, based on field verifications of existing land-uses. At each interview locality, at least 10 randomly chosen farmers were interviewed, each of who has land holdings of more than 3 hectares situated about and beyond each of the interview localities. Field observations were made about and beyond each of the interview localities to determine areas used or not used for agriculture during different cropping seasons and to corroborate farmers' perceptions about land suitability based on certain land characteristics. From the several field observations in agricultural and non-agricultural lands, it is believed that the number of interview localities, number of farmer respondents, and locations of farmer respondents' land holdings provide a representative sampling of FK about agricultural land suitability.

The farmers classify suitability of their land for certain crops based mainly on cropping season, soil characteristics (i.e. colour, texture, depth), and topographic slope (Table 6.1). The farmers' linguistic descriptions of soil characteristics (except colour) and topographic slope are analogous with scientific descriptions (Table 6.2). The farmers categorize soil colours into only either *Nala regadi* ('black' coloured) or *Chalka* ('red' coloured) even when soils have varying degrees of 'blackness' or 'redness' as indicated on the soil colour chart of Munsell and Birren (1969). The farmers' descriptions of soil texture are roughly equivalent to scientific classifications of soil texture based on clay content (Rao and Raj, 2001) while the farmers' classifications of soil depth and slope roughly correlate with the soil depth and slope classes of Venkateswarlu (2001); hence, the dashed lines in Table 6.2.

There are variations in the way individual farmers perceive suitability of their land based on a combination of several land characteristics (Table 6.1). However, variations in farmers' perceptions about land suitability can be organized into discrete rules by grouping of individual farmers' perceptions hierarchically, in which a major factor (i.e. cropping season) is considered first followed by the minor factors in order of their decreasing ranks (Table 6.3). Note that cropping season is not presented in Table 6.3 because the farmers rank relative importance of soil characteristics and topographic slope based on crops they have to grow in a cropping season. Each of the farmers' knowledge rules thus defined applies to a unique combination of possible crops per cropping season in view of their classification of certain soil characteristics and topographic slope (Table 6.4). The farmers' knowledge rules indicate some form

of 'logic' in regard to their land suitability classifications, which could be a function of the farmers' sharing of common traits, tradition and culture inherited from previous generations.

6.4 FK-based fuzzy modelling of land suitability

The farmers' definitions of cropping seasons, soil properties and topographic slopes (Table 6.2) and their rules for 'land suitability for certain crops' (Table 6.4) were the bases for fuzzy modelling

Table 6.1: Summary of farmers' responses to questionnaire.

| Interview locales | Local soil colour | Soil texture | Soils depth | Slope | <i>Kharif</i> | <i>Kharif+Rabi</i> | <i>Rabi</i> |
|----------------------|----------------------|-----------------|----------------|--------|---------------------|----------------------|-------------------|
| 1 | <i>Nala Regadi</i> | Fine | Deep | Flat | Paddy | Paddy/Fallow | Groundnuts/Fallow |
| 2 | <i>Chalka</i> | Fine | Deep | Flat | Paddy/Jowar | Paddy/Fallow | Sugarcane/Fallow |
| 3 | <i>Nala Regadi</i> | Coarse | M.Deep | Flat | Maize/Turmeric | Cotton/Groundnuts | Pulses/Jowar |
| 4 | <i>Chalka</i> | Fine | M.Deep | Flat | Paddy | Sugarcane | Sugarcane |
| 6 | <i>Nala Regadi</i> | Fine | M.Deep | Flat | Paddy | Paddy | Paddy |
| 5 | <i>Chalka</i> | Fine | Deep | Flat | Paddy/Fallow | Paddy/Fallow | Paddy/Fallow |
| 8 | <i>Chalka</i> | M.Fine | Deep | Flat | Paddy/Turmeric | Paddy/Fallow | Paddy/Fallow |
| 7 | <i>Chalka</i> | Fine | M.Deep | Flat | Paddy/Groundnuts | Paddy/Fallow | Paddy/Fallow |
| 9 | <i>Nala Regadi</i> | Fine | Deep | Flat | Paddy/Vegetables | Paddy/Fallow | Sugarcane/Fallow |
| 10 | <i>Chalka</i> | Fine | Deep | Flat | Paddy/Groundnuts | Paddy/Fallow | Sunflower |
| 12 | <i>Nala Regadi</i> | Fine | M.Deep | Gentle | Paddy/Groundnuts | Paddy/Vegetables | Sunflower/Fallow |
| 11 | <i>Chalka</i> | Fine | M.Deep | Gentle | Paddy/Jowar | Groundnuts/Turmeric | Sunflower/Fallow |
| 13 | <i>Nala Regadi</i> | Coarse | Deep | Flat | Cotton/Groundnuts | Paddy/Fallow | Jowar/Bajra |
| 14 | <i>Chalka</i> | Fine | M.Deep | Flat | Paddy/Vegetables | Paddy/Fallow | Sunflower/Fallow |
| 15 | <i>Chalka</i> | Fine | Deep | Mod. | Paddy/Cotton | Maize/Fallow | Jowar/Fallow |
| 17 | <i>Nala Regadi</i> | M.Fine | M.Deep | Flat | Paddy/Sugarcane | Jowar/Maize | Paddy/Fallow |
| 16 | <i>Chalka</i> | Coarse | Deep | Mod. | Jowar/Maize | Jowar/Sunflower | Safflower/Fallow |
| 19 | <i>Nala Regadi</i> | Fine | M.Deep | Flat | Paddy/Vegetables | Safflower/Sunflower | Jowar/Bajra |
| 18 | <i>Chalka</i> | Coarse | M.Deep | Flat | Groundnuts/Turmeric | Jowar/Fallow | Sunflower/Fallow |
| 20 | <i>Nala Regadi</i> | Fine | Deep | Gentle | Paddy/Sunflower | Cotton/Fallow | Safflower/Fallow |
| 21 | <i>Chalka</i> | Fine | M.Deep | Mod. | Paddy/Vegetables | Vegetables | Sugarcane/Fallow |
| 23 | <i>Nala Regadi</i> | Fine | M.Deep | Mod. | Paddy/Fallow | Vegetables/Fallow | Cotton/Fallow |
| 22 | <i>Chalka</i> | Fine | Deep | Gentle | Paddy/Fallow | Groundnuts/Fallow | Sunflower/Fallow |
| 24 | <i>Nala Regadi</i> | Fine | M.Deep | Mod. | Paddy/Vegetables | Sugarcane/Fallow | Sugarcane/Fallow |
| 25 | <i>Chalka</i> | M.Fine | M.Deep | Flat | Paddy/Sugarcane | Sugarcane/Fallow | Sugarcane/Fallow |
| 26 | <i>Chalka</i> | Fine | Deep | Gentle | Paddy/Sugarcane | Sugarcane/Vegetables | Groundnuts/Fallow |

of available spatial data for FK-based classification of agricultural land suitability. The spatial data consists of maps derived from the soil database (i.e. soil colour map, soil clay content map, soil depth map), a slope map (derived from a digital elevation model), and a land-use map other than the LRDP map (Figure 6.4). Data for soil colour and soil clay content pertain to tillable depth of soil (i.e. ~30 cm).

6.4.1 Generation of fuzzy factor maps

The farmers' perception of cropping season or soil colour is intrinsically binary (Table 6.4). That is, 'this land is suitable when the cropping season is this and not that' and 'this land is suitable for certain crops because the soil colour is this and not that'. 'Binary' fuzzy factor maps were thus generated for cropping season and for soil colour.

Based on the land-use map (Figure 6.4), which was used in the fieldwork as reference map to determine zones cultivated by the farmers during different cropping seasons, binary *Kharif*, binary '*Kharif+Rabi*', and binary *Rabi* maps were created. In each of these binary maps, zones indicated by the farmers as suitable and non-suitable for agriculture in certain cropping seasons were assigned fuzzy membership of 0.95 and 0.05, respectively, instead of 1 and 0. Fuzzy membership of 1 and 0 were not assigned to suitable zones and non-suitable zones, respectively, based on cropping season because the farmers are not absolutely (say, only about 95%) certain that a zone is completely suitable or completely non-suitable.

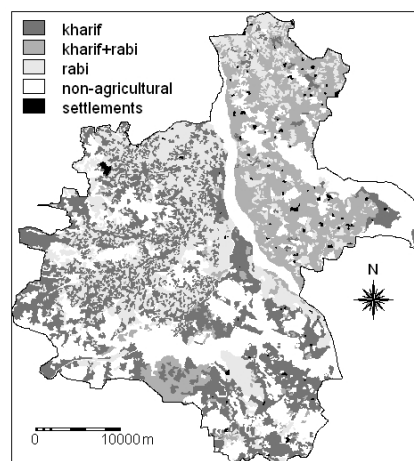

Figure 6.4. Re-classified land-use map of study area.

Table 6.2: Farmers' definitions vs. scientific definitions of some soil properties and topographic slope.

| Farmers' soil colour definition | Scientific soil colour definition (Munsell and Birren, 1969) | |
|---------------------------------|--|-------------------|
| | Code | Description |
| <i>Nala regadi</i> | 5YR 3/1 | Very dark gray |
| <i>Nala regadi</i> | 10R 2.5/1 | Reddish black |
| <i>Chalka</i> | 10R 4/6 | Red |
| <i>Chalka</i> | 10R 4/1 | Dark reddish gray |
| <i>Chalka</i> | 2.5YR 4/4 | Reddish brown |

| Farmers' soil texture definition | Scientific soil texture definition (Rao and Raj, 2001) | |
|----------------------------------|--|-------------------|
| | Texture (% clay) | Description |
| Coarse | < 10 | Coarse |
| Moderately | 10-20 | Moderately coarse |
| Fine | 20-30 | Moderately fine |
| | > 30 | Fine |

| Farmers' soil depth definition | Scientific soil depth definition (Venkateswarlu, 2001) | |
|--------------------------------|--|--------------|
| | Depth (cm) | Description |
| Shallow | < 10 | Very shallow |
| | 10-25 | Shallow |
| Medium deep | 25-50 | Medium deep |
| | 50-100 | Deep |
| Deep | >100 | Very deep |

| Farmers' slope definition | Scientific slope definition (Venkateswarlu, 2001) | |
|---------------------------|---|---------------------|
| | Slope (%) | Description |
| | 0-1 | Nearly level |
| Flat | 1-3 | Very gently sloping |
| | 3-5 | Gently sloping |
| Gentle | 5-10 | Moderately sloping |
| | 10-15 | Strongly sloping |
| Moderate | 15-33 | Steep |
| | >33 | Very steep |

The soil colour map was re-classified into a binary map of *Nala regadi* soils and into a binary map of *Chalka* soils. In each of these binary maps, for example in the binary map of *Chalka* soils, *Chalka* zones and non-*Chalka* zones were assigned fuzzy membership of 0.95 and 0.05. Fuzzy membership of 1 and 0 were not assigned to zones with soil colour considered suitable and non-suitable, respectively, because the farmers are not absolutely (say, only about 95%) certain whether all the soils in, for example, *Chalka* zones are completely *Chalka* or completely non-*Chalka*.

The farmers' perceptions of soil depth, soil texture and topographic slope (Table 6.2) are intrinsically non-binary. Thus, multi-class fuzzy factor maps were generated for (a) soil depth, (b) soil texture and (c) topographic slope using

either Equations 1 or 2. In using either Equations 1 or 2, we used a lowest and a highest fuzzy membership grade of 0.01 and 0.99, respectively, instead of 0 and 1. This is because the farmers are not absolutely (say, at most 99%) certain about degree of agricultural suitability of their land based on soil depth, soil texture or slope.

Table 6.3: Farmers' ranking of factor importance, factor grades and weights for factors.

| Interview locales | Farmers' original rankings (from interviews) | | | | Factor grades (converted ranks) | | | |
|----------------------|---|--------------|------------|-------|---------------------------------|---------------------------|-------------------------|--------------------|
| | Soil colour | Soil texture | Soil depth | Slope | Soil colour (x_1) | Soil texture (x_2) | Soil depth (x_3) | Slope (x_4) |
| 1, 2 | 2 | 1 | 3 | 4 | 3 | 4 | 2 | 1 |
| 3, 4 | 1 | 2 | 3 | 4 | 4 | 3 | 2 | 1 |
| 5, 6 | 1 | 2 | 3 | 4 | 4 | 3 | 2 | 1 |
| 7, 8 | 3 | 1 | 2 | 4 | 2 | 4 | 3 | 1 |
| 9, 10 | 1 | 2 | 3 | 4 | 4 | 3 | 2 | 1 |
| 11, 12 | 1 | 2 | 3 | 4 | 4 | 3 | 2 | 1 |
| 13, 14 | 1 | 2 | 3 | 4 | 4 | 3 | 2 | 1 |
| 15 | 1 | 3 | 2 | 4 | 4 | 2 | 3 | 1 |
| 16, 17 | 2 | 1 | 3 | 4 | 3 | 4 | 2 | 1 |
| 18, 19 | 1 | 2 | 3 | 4 | 4 | 3 | 2 | 1 |
| 20, 21 | 4 | 2 | 1 | 3 | 1 | 3 | 4 | 2 |
| 22, 23 | 1 | 2 | 3 | 4 | 4 | 3 | 2 | 1 |
| 24, 25 | 1 | 2 | 3 | 4 | 4 | 3 | 2 | 1 |
| 26 | 2 | 1 | 3 | 4 | 3 | 4 | 2 | 1 |
| | Sum of grades per factor ($\sum x_i$) | | | | 48 | 45 | 32 | 15 |
| | Sum of all grades ($\sum \sum x_i$) | | | | 140 | | | |
| | Weight per factor ($\sum x_i \div \sum \sum x_i$) | | | | 0.34 | 0.32 | 0.23 | 0.11 |

The farmers consider 'medium deep' to 'deep' soils suitable for agriculture (Tables 6.1 and 6.4); their maximum 'deep' soil is about five times their minimum 'medium deep' or about 125 cm (Table 6.2). A fuzzy set of suitable soil depths (i.e. 'medium deep' to 'deep') with an increasing S-membership function was generated (Table 6.5); that is, soil depths less than 25 cm were assigned fuzzy membership of 0.01, soil depths greater than 125 cm were assigned fuzzy membership of 0.99, and soil depths ranging from 25 to 125 cm were assigned increasing fuzzy membership of 0.01 to 0.99.

The farmers' definitions of soil texture (Table 6.2) were modelled using soil clay content data. The farmers' 'coarse' soils correspond to soils with minimum clay content of about 4% and maximum clay content of about 20%; thus, a fuzzy set of 'coarse' soils with a decreasing S-membership function was created (Table 6.5). The farmers' 'moderately fine' soils correspond to soils with 4-46% clay and their 'optimum moderately fine' soils correspond to soils with 20-30% clay; thus, a fuzzy set of 'moderately fine' soils defined by increasing and decreasing

S-membership functions was created (Table 6.5) and soils with 20-30% clay were assigned fuzzy values of 0.99. The farmers' 'fine' soils correspond to soils with minimum clay content of about 30% and maximum clay content of about 46%; thus, a fuzzy set of 'fine soils' with an increasing S-membership function was created (Table 6.5).

Table 6.4: Farmers' knowledge rules of crop suitability of their land.

| RULE | IF | AND | OR | | | THEN |
|------|---------------------|--------------------|----------------|----------------|--------------------|-------|
| | Cropping season | Soil colour | Soil texture | Soil depth | Slope | Crop' |
| 1 | <i>Khariif</i> | <i>Nala Regadi</i> | Fine to M.Fine | M.Deep to Deep | Flat to Gentle | 1 |
| 2 | <i>Khariif</i> | <i>Nala Regadi</i> | Coarse | M.Deep to Deep | Gentle to Moderate | 2 |
| 3 | <i>Khariif</i> | <i>Chalka</i> | Fine to M.Fine | M.Deep to Deep | Flat to Gentle | 5 |
| 4 | <i>Khariif</i> | <i>Chalka</i> | Coarse | M.Deep to Deep | Gentle to Moderate | 6 |
| 5 | <i>Khariif+Rabi</i> | <i>Nala Regadi</i> | Fine to M.Fine | M.Deep to Deep | Flat to Gentle | 1 |
| 6 | <i>Khariif+Rabi</i> | <i>Nala Regadi</i> | Coarse | M.Deep to Deep | Gentle to Moderate | 2 |
| 7 | <i>Khariif+Rabi</i> | <i>Chalka</i> | Fine to M.Fine | M.Deep to Deep | Flat or Gentle | 7 |
| 8 | <i>Khariif+Rabi</i> | <i>Chalka</i> | Coarse | M.Deep to Deep | Flat to Gentle | 3 |
| 9 | <i>Rabi</i> | <i>Nala Regadi</i> | Fine to M.Fine | M.Deep to Deep | Flat to Gentle | 3 |
| 10 | <i>Rabi</i> | <i>Nala Regadi</i> | Coarse | M.Deep to Deep | Flat to Gentle | 4 |
| 11 | <i>Rabi</i> | <i>Chalka</i> | Fine to M.Fine | M.Deep to Deep | Flat to Gentle | 8 |
| 12 | <i>Rabi</i> | <i>Chalka</i> | Coarse | M.Deep to Deep | Gentle to Moderate | 3 |

'1 = paddy, fallow, vegetables, groundnuts; 2 = maize, turmeric, cotton, groundnuts; 3 = jowar, maize, safflower, sunflower; 4 = jowar, pulses, bajra; 5 = paddy, sugarcane, cotton; 6 = jowar, maize, groundnuts, turmeric; 7 = paddy, vegetables, safflower, sunflower; 8 = jowar, bajra.

The farmers' definitions of slopes were modelled based on the topographic slopes in the area, which vary from 0.8% to 24%. The minimum of the farmers' 'flat' slopes is about 10%; thus, a fuzzy set of 'flat' slopes was generated with a decreasing S-membership function (Table 6.5). The farmers' 'optimum gentle' slopes correspond to a gradient range of 10-14%; thus, a fuzzy set of 'gentle' slopes with increasing and decreasing S-membership functions was created (Table 6.5) and slopes of 10-14% were assigned fuzzy values of 0.99. The farmers' 'moderate' slopes have a minimum gradient of about 14%; thus, a fuzzy set of 'moderate' slopes was generated with an increasing S-membership function (Table 6.5).

Table 6.5: Parameters used to generate S-membership functions of multi-class fuzzy factor maps.

| Fuzzy factor | S-membership function | |
|-------------------------|-----------------------|--|
| | Type | Equation and parameters used |
| Soil depth | Increasing | Equation 1; with $\alpha=25$ cm, $\beta=75$ cm and $\gamma=125$ cm |
| 'Coarse' soils | Decreasing | Equation 2; with $\alpha=4\%$ clay, $\beta=12\%$ clay and $\gamma=20\%$ clay |
| 'Moderately fine' soils | Increasing | Equation 1; with $\alpha=4\%$ clay, $\beta=12\%$ clay and $\gamma=20\%$ clay |
| | Decreasing | Equation 2; with $\alpha=30\%$ clay, $\beta=38\%$ clay and $\gamma=46\%$ clay |
| 'Fine' soils | Increasing | Equation 1; with $\alpha=30\%$ clay, $\beta=38\%$ clay and $\gamma=46\%$ clay |
| 'Flat' slopes | Decreasing | Equation 2; with $\alpha=0.8\%$ slope, $\beta=5.4\%$ slope and $\gamma=10\%$ slope |
| 'Gentle' slopes | Increasing | Equation 1; with $\alpha=0.8\%$ slope, $\beta=5.4\%$ slope and $\gamma=10\%$ slope |
| | Decreasing | Equation 2; with $\alpha=14\%$ slope, $\beta=19\%$ slope and $\gamma=24\%$ slope |
| 'Moderate' slopes | Increasing | Equation 1; with $\alpha=14\%$ slope, $\beta=19\%$ slope and $\gamma=24\%$ slope |

The fuzzy factor maps were then assigned weights based on the farmers' ranking of importance of each land characteristic in regard to agricultural suitability. Aside from cropping season, the farmers rank soil colour as the most important factor followed by soil texture, soil depth and slope (Table 6.3). To derive factor weights that are consistent with the FK (i.e. weights reflect importance), the original ranks were first converted to grades (x_i); i.e. rank 1 equals grade 4 ('most important') while rank 4 equals grade 1 ('least important') (Table 6.3). The grades per factor were added (i.e. $\sum x_i$) and the sums of grades per factor were then added (i.e. $\sum \sum x_i$). The weight per factor was derived by dividing sum of grades per factor by sum of all grades (i.e. $\sum x_i \div \sum \sum x_i$). Each calculated weight was then multiplied to the pertinent fuzzy factor map (excluding the fuzzy maps based on cropping season).

6.4.2 Generation of land suitability maps

The FK rules (Table 6.4), each of which forms an inference engine for fuzzy modelling, axiomatically indicate combined applications of Fuzzy AND (FA) and Fuzzy OR (FO) operators and preclude applications of other fuzzy operators to integrate pertinent fuzzy factor maps. Suppose input fuzzy factor maps A , B and C with μ_A , μ_B and μ_C , respectively, as membership values of each of their attributes and with W_A , W_B and W_C , respectively, as map weights. Using the FA operator, output integrated fuzzy values $\mu_{combination}$ are obtained as:

$$FA \mu_{combination} = MIN(W_A \mu_A, W_B \mu_B, W_C \mu_C \dots). \quad (3)$$

The MIN operator looks for and takes as output the minimum fuzzy value at each point (or pixel) in any input map; it is equivalent but not equal to a

Boolean AND operator. Using the FO operator, output integrated fuzzy values $\mu_{combination}$ are obtained as:

$$FO \mu_{combination} = MAX(W_A\mu_A, W_B\mu_B, W_C\mu_C \dots). \quad (4)$$

The MAX operator looks for and takes as output the maximum value at each point (or pixel) in any input map; it is equivalent but not equal to a Boolean OR operator.

However, the words AND and OR in the farmers' local dialect may not strictly mean the same as FA and FO, respectively. This suggests the need to apply and evaluate results of application of other fuzzy operators vis-à-vis the farmer respondents' perceptions of land suitability. The other fuzzy operator used was the Fuzzy Algebraic Sum (FAS), by which output integrated fuzzy values $\mu_{combination}$ are obtained as:

$$FAS \mu_{combination} = 1 - \prod_{i=1}^n (1 - W_i\mu_i) \quad (5)$$

Where, W_i and μ_i are, respectively, the weight of and the fuzzy values in input fuzzy factor map i , and $i = 1, 2, \dots, n$ input fuzzy factor maps to be combined. The output of FAS for each point is always larger than, or equal to, the maximum fuzzy value at the same point in any input map (i.e. it has 'maximizing' effect). The FAS operator, due to its 'maximizing' effect, was tested because it may represent the fact that many farmers' 'overestimate' suitability of their land (i.e. they maximize utilization of their land in an unsustainable manner).

The output of integrating the FK fuzzy factor maps is a map of fuzzy values indicating degrees of suitability. The resulting fuzzy suitability maps were defuzzified to partition the fuzzy values into suitability classes by using inflection points along plots of cumulative frequency (i.e. cumulative percentage of pixels) of fuzzy values. These inflection points represent a sudden increase in number of pixels with a minor change in fuzzy values and were therefore interpreted to represent threshold fuzzy values, which allow differentiation between zones that are 'least suitable', 'moderately suitable', 'suitable' or 'most suitable' for agriculture.

6.4.3 Evaluation of land suitability maps

The FK-based suitability maps were compared with the LRDP map to (a) determine degrees of similarity and (b) identify areas of agreement and conflict.

To determine degrees of similarity, a uniform classification was necessary because the FK-based maps represent agricultural land suitability zones with four classes while the LRDP map represents land-use units with 18 classes. The LRDP map and the FK-based suitability maps were therefore re-classified into two classes, 'agricultural' and 'non-agricultural' zones. For the LRDP map, the different land-use units were simply re-classified as either 'agricultural' or 'non-agricultural' zones (Table 6.6). For the FK-based maps, zones initially mapped as 'suitable' and 'most suitable' were re-classified as 'agricultural' zones while zones mapped as 'least suitable' and 'moderately suitable' were re-classified as 'non-agricultural' zones. Then, the re-classified FK-based maps for a cropping season (Table 6.4) were combined, through a Boolean OR operation, into a map depicting zones suitable for agricultural and for non-agricultural purposes during a cropping season. To measure degrees of similarity, map overlay operations were performed to determine overlap between FK-based and LRDP 'agricultural' zones and overlap between FK-based and LRDP 'non-agricultural' zones. Degree of similarity (expressed in percent) between a seasonal FK-based suitability map and the LRDP map was calculated as the sum of number of pixels of overlap between 'agricultural' zones and number of pixels of overlap between 'non-agricultural' zones divided by total number of pixels and multiplied by 100. The measured degree of similarity is known in the geographic literature as the coefficient of areal association (Taylor, 1977).

To identify areas of agreement and/or conflict, each of the re-classified seasonal FK-based suitability maps were overlaid on the original LRDP map to determine percentages of mapped 'agricultural' zones in each of the LRDP land-use units.

6.5 Results

Figure 6.5 shows the 'binary' fuzzy factor maps for *Kharif*, '*Kharif+Rabi*' and *Rabi* and the 'binary' fuzzy factor maps for 'dark-coloured' and for 'red-coloured' soils. Figure 6.6 shows the multi-class fuzzy factor maps based on soil depth, soil texture and slope. For illustration purposes and due to the limited space here, only the results of combining fuzzy factor maps pertinent to FK rule 1 (Table 6.4) are shown and described.

Table 6.6: Agreement and conflict between LRDP map and FK-based suitability maps.

| Land-use units in LRDP map | | | FK-based agricultural zones in LRDP land-use units (%) | | |
|--|-----------------|-------------------|--|--------------------|-------------|
| Original classification | % of study area | Reclassification* | <i>Kharif</i> | <i>Kharif+Rabi</i> | <i>Rabi</i> |
| Agro-horticulture With Soil Conservation Measures | 21.2 | A | 84 | 9 | 65 |
| Double Cropping and/or Agrohorticulture with Ground Water Exploitation | 17.4 | A | 82 | 4 | 71 |
| Dry Land Horticulture | 0.3 | A | 100 | 1 | 41 |
| Existing Agriculture in Notified Forest area | 0.7 | A | 90 | 49 | 46 |
| Horticulture | 1.5 | A | 80 | 9 | 73 |
| Horti-pasture (non-irrigated) | 7.9 | A | 55 | 23 | 57 |
| Intensive Agriculture | 22.5 | A | 93 | 72 | 84 |
| Rainfed Agro-horticulture/Agro-forestry | 5.5 | A | 92 | 1 | 63 |
| Silvi-pasture and/or Agro-forestry | 0.1 | A | 10 | 98 | 100 |
| Afforestation | 0.1 | NA | 74 | 6 | 99 |
| Fodder and Fuel Wood Plantation | 2.6 | NA | 75 | 20 | 61 |
| Forest Conservation/Protection | 8.3 | NA | 66 | 21 | 76 |
| Forestgap Plantation | 4.5 | NA | 45 | 13 | 53 |
| Quarrying and Mining Activities | 0.1 | NA | 94 | 25 | 100 |
| Silvi Pasture and/or Economic Forest Plantation | 3.1 | NA | 62 | 37 | 68 |
| Social Forestry and Pasture Development | 1.2 | NA | 75 | 12 | 95 |
| Tank Foreshore Plantation | 2.0 | NA | 54 | 2 | 50 |
| Settlements | 1.0 | NA | - | 12 | - |

*A = agricultural zones; NA = non-agricultural zones.

Figure 6.7a shows the cumulative frequency plot of fuzzy values in the map resulting from combining fuzzy factor maps pertinent to FK rule 1 through applications of FA and FO. Figure 6.7b shows the defuzzified map based on the inflection points. This map indicates that the farmers consider flat slopes with dark, fine-textured and deep soils as 'most suitable' for Crop Group 1 during *Kharif* (Table 6.4). In the northeastern part, many zones not considered suitable as *Kharif* crop zones (Figure 6.5) are mapped as 'suitable' zones. This is due to the fuzzy factor map of 'flat' slopes and to the fuzzy factor map of 'moderately fine' soils (Figure 6.6). This result is, however, coherent with the farmers' perception that moderately fine soils in flat zones could adequately sustain water needed by crops in Crop Group 1 during *Kharif* (Table 6.4). This indicates that FK Rule 1 is adequately modelled by application of FA and FO. The results of application of these operators to the other FK Rules are also mostly coherent with the farmers' perception of suitability of their land.

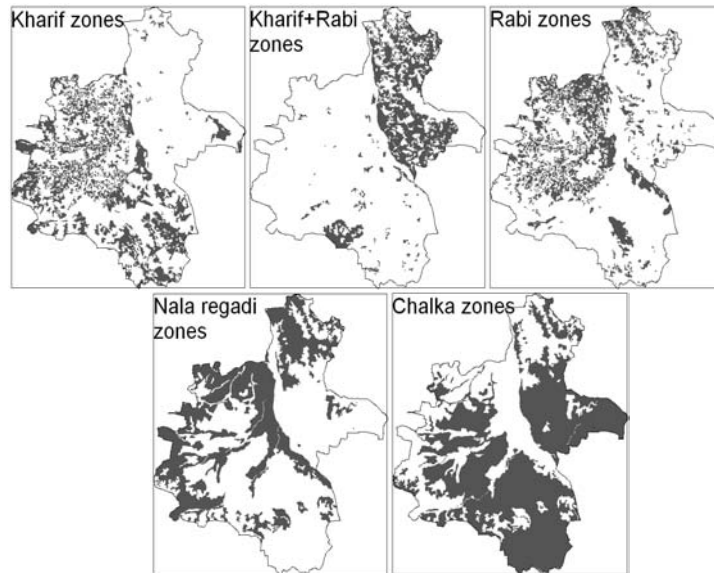

Figure 6.5. Binary' fuzzy factor maps: *Kharif* zones; '*Kharif+Rabi*' zones; *Rabi* zones; *nala regadi* zones; and *chalka* zones. Fuzzy values are 0.95 and 0.05 for black and white zones, respectively.

Figure 6.7c shows the cumulative frequency plot of fuzzy values in the map resulting from combining fuzzy factor maps pertinent to FK rule 1 through application of FAS. Figure 6.7d shows the defuzzified map based on the inflection points. In this map, there are very few zones classified as 'most suitable' and are not visible at the present map scale. 'Suitable' zones are characterized by *Nala regadi*, fine-textured and deep soils (Figures 6.5 and 6.6). 'Moderately suitable' zones are characterized mainly by dark, fine-textured and deep soils on flat slopes. 'Least suitable' zones mostly pertain to flat slopes. Such classifications are non-coherent with the farmers' perceptions of land suitability for Crop Group 1 during *Kharif*. This indicates that FAS inadequately models FK Rule 1. The results of application of FAS to the other FK Rules are also mostly non-coherent with the farmers' perception of suitability of their land.

The degrees of similarity between the re-classified seasonal FK-based suitability maps derived from the combined applications of FA and FO and the re-classified LRDP map (Figure 6.8) were then evaluated. The degrees of similarity of the re-classified FK-based suitability maps for *Kharif*, *Kharif + Rabi* and *Rabi* with the re-classified LRDP map are 73%, 40% and 62%, respectively. Table 6.6

further shows how the re-classified seasonal FK-based suitability maps agree/conflict with the LRDP map.

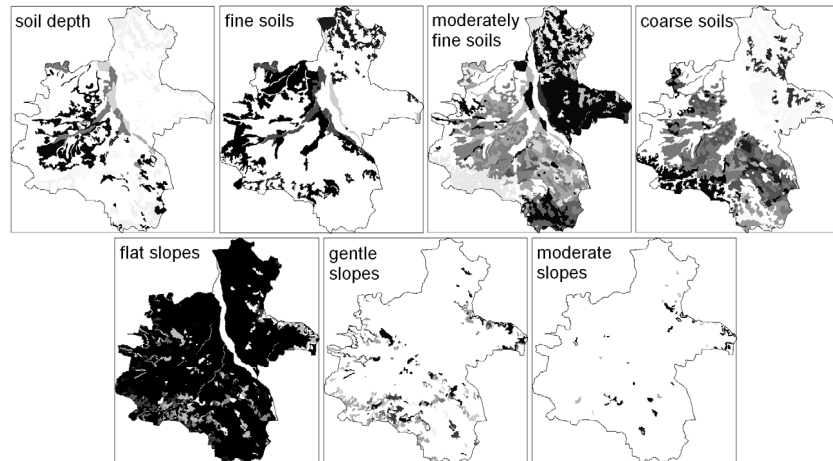

Figure 6.6. Fuzzy factor maps based on soil depth, soil texture (fine, moderately fine, soarse) and slope (flat, gentle, moderate). Fuzzy values vary from 0.99 (black) to 0.01 (white).

For *Kharif*, there is mostly very strong (>80%) agreement between FK-based 'agricultural' zones and most LRDP 'agricultural' zones (Table 6.6). Of the LRDP 'agricultural' zones, only the non-irrigated Horti-pasture zones (i.e. grazing areas in plantations, orchards, etc.) moderately agree with FK-based 'agricultural' zones' and only the Silvi Pasture and/or Agro-forestry zones very weakly agree with FK-based 'agricultural' zones. However, there is moderate to strong (45-75%) conflict between FK-based 'agricultural' zones and LRDP 'non-agricultural' zones. This latter observation suggests that the farmers consider land characteristics in most LRDP 'non-agricultural' zones as suitable for agriculture during *Kharif*.

For *Kharif+Rabi*, there is mostly weak (<30%) to very weak (<10%) agreement between FK-based 'agricultural' zones and most LRDP 'agricultural' zones (Table 6.6). Of the LRDP 'agricultural' zones, only the Existing Agriculture in Notified Forest areas moderately agree with FK-based 'agricultural' zones' while only the Intensive Agriculture areas and the Silvi-pasture and/or Agro-forestry areas strongly agree with FK-based 'agricultural' zones. These observations suggest that the farmers consider land characteristics in most LRDP 'agricultural' zones as generally unsuitable for agriculture during

Kharif+Rabi. It is, however, interesting to note that there is mostly very weak to weak (<30%) conflict between FK-based 'agricultural' zones and LRDP 'non-agricultural' zones. This observation suggests that the farmers consider land characteristics in LRDP 'non-agricultural' zones as generally unsuitable for agriculture during *Kharif+Rabi*.

For *Rabi*, there is moderate to very strong agreement between FK-based 'agricultural' zones and LRDP 'agricultural' zones (Table 6.6). However, there is also moderate (~50%) to very strong (>80%) conflict between FK-based 'agricultural' zones and LRDP 'non-agricultural' zones. This latter observation suggests that the farmers consider land characteristics in most LRDP 'non-agricultural' zones as generally suitable for agriculture during *Rabi*.

6.6 Discussion

Generation of fuzzy factor maps based on FK can be straightforward or problematical. Generation of a FK-based fuzzy factor map is relatively straightforward if correlation or equivalence between farmers' definition and scientific classifications of certain land characteristics can be established. Establishment of correlation or equivalence between farmers' definition and scientific classifications allows recognition of pertinent spatial data that could be used to generate FK-based fuzzy factor maps. Hence, FK-based fuzzy factor maps representing slope, soil depth, and soil texture were generated using slope map, soil depth data, and soil clay content data, respectively. In generating these fuzzy factor maps by application of appropriate S-membership function, a lower limit of 0.01 and an upper limit of 0.99, based on FK, were used instead of 0 (i.e. completely unsuitable) and 1 (i.e. completely suitable), respectively. This is because in knowledge-driven fuzzy modelling there are no matter-of-fact constraints on the choice of fuzzy membership functions or values except that such membership functions should reflect the context of the factor being modelled (in this case based on FK context) and the membership values, inclusive of lower and upper limits, must lie in the range of 0 to 1 (i.e. lower and upper limits need not be strictly 0 and 1, respectively).

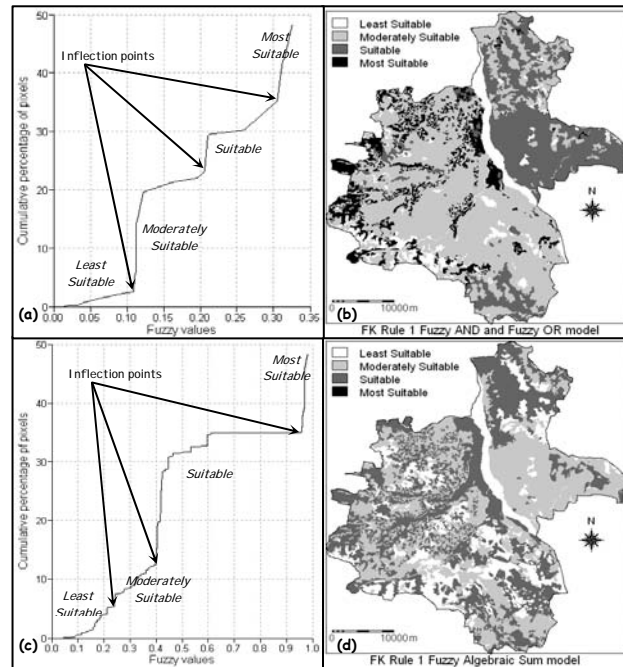

Figure 6.7. Fuzzy factor maps based on soil depth, soil texture (fine, moderately fine, coarse) and slope (flat, gentle, moderate). Fuzzy values vary from 0.99 (black) to 0.01 (white).

In contrast to the relative simplicity in generating FK-based fuzzy factor maps for slope, soil depth, and soil texture, creating FK-based fuzzy factor maps based on cropping season and soil colour proved problematical. This is because (a) sound correlation or equivalence between farmers' perceptions and scientific classifications of these factors was difficult to establish and/or (b) the farmers' perceptions of either of these factors are essentially binary yet fuzzy. The latter reason applies to cropping seasons while both reasons apply to soil colour. Nevertheless, in recognition of the farmers' binary perceptions of these factors, 'binary' fuzzy factor maps for *Kharif*, *Kharif+Rabi*, and *Rabi* were generated using the existing land-use map (Figure 6.4) while 'binary' fuzzy factor maps for *Chalka* and *Nala regadi* soils were generated using the soil colour map. These 'binary' fuzzy factor maps, in fact, represent binary fuzzy relations between farmers' perceptions of cropping season and existing land-use map and between farmers' perception of soil colour and soil colour data. A binary fuzzy relation R between a certain variable x (e.g., farmers' perceptions of soil colour)

and another variable y (e.g., scientific descriptions of soil colour), whose domains are X and Y , respectively, is a fuzzy subset of $X \times Y$ characterized by its membership function $\mu_R(x,y):X \times Y \rightarrow [0,1]$ (Robinson, 2003). It can be argued that the delineated cropping season zones and soil colour zones are very fuzzy and thus assignment of a single fuzzy membership value (i.e. 0.05 or 0.95) to each of these zones depending on certain farmers' proposition seems inappropriate. However, such rough fuzzification of cropping season zones and soil zones based on FK does not negate usefulness of the approach, but only indicates how farmers in the study area perceive reality, which should be considered in modelling pertinent spatial data based on FK.

The multi-class fuzzy factor maps of slope, soil depth, and soil texture can be considered fuzzy rough sets while the binary fuzzy factor maps of cropping season and soil colour can be considered rough fuzzy sets (Thiele, 1998). Since the binary fuzzy relations generated for cropping season and soil colour are also fuzzy sets, they can also be combined with the fuzzy sets of slope, soil depth, and soil texture by applications of appropriate fuzzy operators. Of the eight criteria enumerated by Zimmerman (1991) for selecting appropriate fuzzy operators, 'axiomatic strength' and 'empirical fit' are more or less satisfied by the farmers' rules (Table 6.6.4). On one hand, the farmer' rules are self-evident (i.e. axiomatic) and therefore require operators that implicitly satisfy them (i.e. the rules or axioms).

On the other hand, the farmers' rules represent practical experiences (i.e. through empirical association and/or commutation) and therefore require operators with certain formal qualities (such as associativity, commutativity) from a mathematical point of view to provide empirical testing. Thus, based on the 'axiomatic strength' criterion, the fuzzy factor maps were combined using FA and FO operators, which implicitly satisfy farmers' linguistic 'and' and 'or', respectively; whereas based on the 'empirical fit' criterion, the fuzzy factor maps were combined using FAS operator, which is associative and commutative.

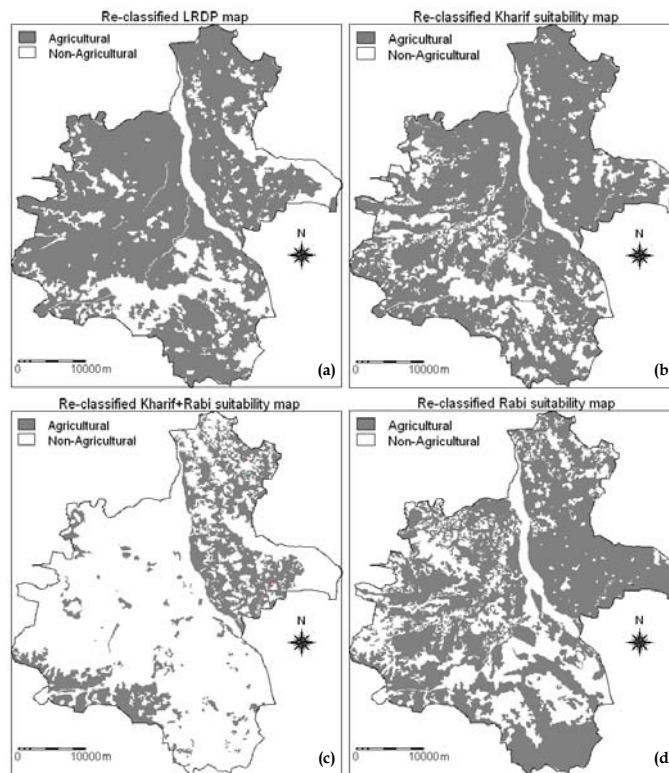

Figure 6.8. Agricultural and non-agricultural zones based on (a) LRDP map; (b) *Kharif* suitability maps; (c) '*Kharif+Rabi*' suitability maps; and (d) *Rabi* suitability maps.

Most of the land suitability maps resulting from applications of FA and FO operators were found more sound than the land suitability maps resulting from applications of FAS operator. The probable reason why most results of applications of FA and FO are sound is that these operators, respectively, 'look' for logical intersection and logical union of factors that indicate suitability, which are consistent with the FK rules. Most of the results of application of FAS, on the other hand, are unsound partly because this operator results in 'maximized' (or highly optimistic) models and partly because this operator is representative of the fact that many but not all farmers' 'overestimate' (or are highly optimistic about) suitability of their land.

The degrees of similarity (ranging from about 40% to about 73%), the areas of agreement and the areas of conflict identified between the re-classified seasonal FK-based suitability maps and the re-classified or original LRDP map indicate mainly that local farmers' perception of utilizing their land differ from the

prescribed land-uses. Sound FK-based land suitability maps can thus be important sources of information indicating points of interventions or terms of reference that authorities need to consider in order to prepare optimum land-use plans. However, it is not the intention of our study to contest the LRDP map but to demonstrate FK-based modelling of relevant spatial data for land suitability classification with application of the theory of fuzzy sets, which is a tested theory for dealing with vague concepts. With adoption and/or further adaptations of fuzzy modelling of FK presented here, it is believed that FK or indigenous knowledge, in general, can be integrated properly with scientific models of land suitability derived also through fuzzy modelling (e.g., Van Ranst et al., 1996; Groenemans et al., 1997; Kollias and Kalivas, 1998; Nisar Ahamed et al., 2000; Triantafilis et al., 2001; Liu and Samal, 2002; Malczewski, 2002; Ceballos-Silva and López-Blanco, 2003).

6.7 Conclusions

Farmers' definitions of certain land characteristics, which they consider important in determining land suitability, are intrinsically vague. If correspondence between farmers' definitions and scientific classifications of certain land characteristics can be established, then FK-based modelling of pertinent spatial data into fuzzy sets is relatively straightforward. If correspondence between farmers' definitions and scientific classifications of certain land characteristics cannot be established and if farmers' perceptions are binary, then relevant spatial data can be modelled by binary fuzzy relations, which are also fuzzy sets. Individual farmers' perceptions about land suitability based on combinations of different factors can be organized into discrete rules by grouping such different perceptions hierarchically according to factors arranged in order of decreasing importance. The FK rules form inference engines and indicate which fuzzy operators are appropriate for combining fuzzy factor maps. For the study area, combined applications of Fuzzy AND and Fuzzy OR operators result in agricultural land suitability maps that are mostly consistent with the FK rules. FK-based fuzzy modelling of land suitability maps can provide useful information that authorities need to consider in generating optimum land-use plans. The study further suggests that, in land suitability classifications, indigenous and scientific knowledge can be integrated properly through fuzzy modelling.

References

- Beek, M.A., 2000. Fuzzy logic analysis for modelling of natural resources processes. *International Archives of Photogrammetry and Remote Sensing* 33 (part B4), 118-125.
- Bonham-Carter, G.F., 1994. *Geographic Information Systems for Geoscientists, Modelling with GIS*. Pergamon, Ontario.
- Burrough, P.A., MacMillan, R.A., van Deursen, W., 1992. Fuzzy classification methods for determining land suitability from soil profile observations and topography. *Journal of Soil Science* 43, 193-210.
- Carranza, E.J.M., Hale, M., 2001. Geologically-constrained fuzzy mapping of gold mineralization potential, Baguio district, Philippines. *Natural Resources Research* 10, 125-136.
- Ceballos-Silva, A., López-Blanco, J., 2003. Evaluating biophysical variables to identify suitable areas for oat in Central Mexico: a multi-criteria and GIS approach. *Agriculture, Ecosystems and Environment* 95, 371-377.
- Cools, N., De Pauw, E., Deckers, J., 2003. Towards an integration of conventional land evaluation methods and farmers' soil suitability assessment: a case study in northwestern Syria. *Agriculture, Ecosystems and Environment* 95, 327-342.
- Davidson, D.A., Theocharopoulos, S.P. and Bloksma, R.J., 1994. A land evaluation project in Greece using GIS and based on Boolean and fuzzy set methodologies. *International Journal of Geographical Information Systems* 8, 369-384.
- FAO, 1993. *Guidelines for Land-use Planning*. FAO Development Series No.1, FAO, Rome, 96 pp.
- FAO, 1997. *Participation in practice: lessons from the FAO People's Participation Programme*. <http://www.fao.org/waicent/faoinfo/sustdev/PPdirect/PPre0044.htm>
- Gonzalez, R.M., 2002. Joint learning with GIS: multi-actor resource management. *Agricultural Systems* 73, 99-111.
- Groenemans, R., van Ranst, Kerre, E., 1997. Fuzzy relational calculus in land evaluation. *Geoderma* 77, 283-298.
- Habarurema, E., Steiner, K.G., 1997. Soil suitability classification by farmers in southern Rwanda. *Geoderma* 75, 75-87.
- Harmsen, K., Nidumolu, U.B., 2002. Land-use planning for sustainable development in south Asia: an example from India. In: R.R. Navalgund et al., (eds.), *Proceedings of ISPRS Commission VII International Symposium*

- on Resource and Environmental Monitoring, December 3-6 2002, Hyderabad, India, National Remote Sensing Agency, India (NRSA).
- Hellendoorn, H., Thomas, C., 1993. Defuzzification in fuzzy controllers. *Journal of Intelligent Fuzzy Systems* 1, 109-123.
- Kollias, V.J. Kalivas, D.P., 1998. The enhancement of a commercial geographical information system (ARC/INFO) with fuzzy processing capabilities for the evaluation of land resources. *Computers and Electronics in Agriculture* 20, 79-95.
- Lawas, C.M., Luning, H.A., 1996. Farmers' knowledge and GIS. *Indigenous Knowledge and Development Monitor* 4, 8-11.
- Lawry, J., 2001. A methodology for computing with words. *International Journal of Approximate Reasoning* 28, 51-89.
- Liu, M., Samal, A., 2002. A fuzzy clustering approach to delineate agroecozones. *Ecological Modelling* 149, 215-228.
- Malczewski, J., 2002. Fuzzy screening for land suitability analysis. *Geographical and Environmental Modelling* 6, 27-39.
- Mathias, E., 1995. Recording indigenous knowledge: an overview. In: J. Schneider (Ed.). *Indigenous Knowledge in Conservation of Crop Genetic Resources*, Proceedings of an international workshop held in Cisarua, Bogor, Indonesia, Jan. 30-Feb. 3, 1995. CIP-ESEAP/CRIFC, Bogor, Indonesia, pp. 19-25.
- McBratney, A.B., Odeh, I.O.A., 1997. Application of fuzzy sets in soil science: fuzzy logic, fuzzy measurements and fuzzy decisions. *Geoderma* 77, 85-113.
- Messing, I., Fagerstrom, M.H.H., 2001. Using farmers' knowledge for defining criteria for qualities in biophysical land evaluation. *Land Degradation and Development* 12, 541-553.
- Munsell, A., Birren, F., 1969. *A Grammar of Colour: A Basic Treatise of the Colour System of Albert H. Munsell*. McGraw-Hill, New York.
- Nisar Ahamed, T.R., Gopal Rao, K., Murthy, J.S.R., 2000. GIS-based fuzzy membership model for crop-land suitability analysis. *Agricultural Systems* 63, 79-97.
- Oudwater, N., Martin, A., 2003. Methods and issues in exploring local knowledge of soils. *Geoderma* 111, 387-401.
- Rao, A.P., Raj, G.B., 2001. *Guidelines for Soil-Based Technologies to Optimise Land Productivity*. Acharya N.G. Ranga Agricultural University, Hyderabad, Andhra Pradesh State, India.
- Roach, T., 1994. Ancient ways guide modern methods. IDRC (International Development Research Center) Reports 22, 9-10.

- Robinson, V.B., 2003. A perspective on the fundamentals of fuzzy sets and their in geographic information systems. *Transactions in GIS* 7, 3-30.
- Ryder, R., 2003. Local soil knowledge and site suitability evaluation in the Dominican Republic. *Geoderma* 111, 289-305.
- Steiner, K.G., 1998. Using farmers' knowledge of soils in making research results more relevant to field practice: experiences from Rwanda. *Agriculture, Ecosystems and Environments* 69, 191-200.
- Tang, H., 1993. Land Suitability Classification based on Fuzzy Set Theory and Modelling of Land Production Potential of Maize and Winter Wheat in Different Zones of China. PhD thesis, University of Ghent, Belgium.
- Taylor, P.J., 1977. *Quantitative Methods in Geography*. Houghton Mifflin Company, Boston-Atlanta.
- Thiele, H., 1998. Fuzzy rough sets versus rough fuzzy sets - an interpretation and a comparative study using concepts of modal logics. Reihe Computational Intelligence CI-30/98, Collaborative Research Center, University of Dortmund, 13 pp.
- Triantafilis, J., Ward, W.T., McBratney, A.B., 2001. Land suitability assessment in the Namoi Valley of Australia, using a continuous model. *Australian Journal of Soil Research* 39, 273-289.
- Van Ranst, E., Tang, H., Groenemans, R. and Sinthurath, S., 1996. Application of fuzzy logic to land suitability for rubber production in peninsular Thailand. *Geoderma* 70, 1-19.
- Venkateswarlu, J., 2001. *Management of Soils in Andhra Pradesh*. Acharya N.G. Ranga Agricultural University, Hyderabad, Andhra Pradesh State, India.
- Wandahwa, P., Van Ranst, E., 1996. Qualitative land suitability assessment for pyrethrum cultivation in west Kenya based upon computer-captured expert knowledge and GIS. *Agriculture, Ecosystems & Environment* 56, 187-202.
- Zadeh, L.H., 1965. Fuzzy sets. *Information and Control* 8, 338-353.
- Zimmerman, H.J., 1991. *Fuzzy Set Theory - and its Applications*, 2nd edn. Kluwer Academic Publisher, Dordrecht.
- Zurayk, R., El-Awar, F., Hamadeh, S., Talhouk, S., Sayegh, C., Chenab, A.G., Al Shab, K., 2001. Using indigenous knowledge in land use investigations: a participatory study in a semi-arid mountainous region of Lebanon. *Agriculture, Ecosystems and Environment* 86, 247-262.

Appendix 6.1. Questionnaire to capture FK in study area.

Village name :

Mandal name :

No. of respondents:

1. What kind of soils do you recognize in your farms?

| Colour | Munsell code | Texture | Depth | Other information |
|--------|--------------|---------|-------|-------------------|
| | | | | |
| | | | | |
| | | | | |

2. What are the local names of these soils?

| Colour | Local name |
|--------|------------|
| | |
| | |
| | |

3. Where are these soils normally found (in terms of slope)?

| Colour | Slope | Other information |
|--------|-------|-------------------|
| | | |
| | | |
| | | |

4. Of the four factors (colour, texture, depth, slope), which of these do you consider most important?

| Factor | Ranking | Remarks |
|---------|---------|---------|
| Colour | | |
| Texture | | |
| Depth | | |
| Slope | | |

5. Are there any other special characteristics of type of soil, such as black soils normally have high fertility?

6. If irrigation water is available/not available, which crops and crop varieties are preferred in your farms based on the season?

| Water availability | | Crop | Season | | |
|--------------------|----|------|--------|-------------|------|
| A | NA | | Kharif | Kharif+Rabi | Rabi |
| | | | | | |
| | | | | | |
| | | | | | |

7. Why, is it because of the soil or other factors? What are these other factors?

8. What crops are best grown or suitable on which soils?

| Crop | Soil colour | Soil texture | Soil depth | Slope | Season | | |
|------|-------------|--------------|------------|-------|--------|-------------|------|
| | | | | | Kharif | Kharif+Rabi | Rabi |
| | | | | | | | |
| | | | | | | | |
| | | | | | | | |

Chapter 7

Synthesis

Human induced decline in land quality is a major global issue during the 20th Century and will continue to be a key cause for concern in the 21st century (Penning de Vries et al., 1998; Oldeman et al., 1991). The UN Conferences focusing on Sustainable Development both at Rio and Johannesburg emphasise the need for improved monitoring of earth's natural resources and the important role of stakeholders; involvement in research supporting sustainable development (Parker et al., 2002; UNCED, 1992; United Nations, 2002). The emphasis in this thesis is on development of methods that integrate geo-information data with participatory approaches as an aid to district level planners for land use analysis. Integrating biophysical parameters with socio-economic expectations is a challenging research area in land use analysis and land use policy formulation. Though the biophysical and socio-economic domains appear as different areas of research, in a way they represent two sides of the same coin. While *land* refers to the biophysical component, its *use* by 'real' people is the representation of the socio-economic component. In this study we developed some innovative methods that integrate remote sensing and GIS-derived biophysical parameters with socio-economic characteristics for land use analysis.

In this thesis (Chapter 2) we have shown that the soft systems methodology (SSM) is useful in a land use planning programme where hard and soft systems converge. SSM, developed as a method for analysing complex human activity processes specifically applied in an organisational context (Checkland, 1992). In this study we used the SSM to analyse a land use planning programme treating it as a system with both 'hard' and soft' system components. The 'Integrated Mission for Sustainable Development (IMSD)', an existing land use planning programme with a focus on bottlenecks that limit its application was analysed. For example, at the root definition stage, the key stakeholders defined their view of the programme as:

Root Definition 1 (as seen by the government)

Improved use of land by the farmers to mitigate the effects of drought on the basis of land and water use *plans developed by the IMSD*, owned by the Central government.

Root Definition 2 (as seen by the farmers)

Improved use of land to mitigate impacts of drought in terms of incomes, land degradation, food production, soil loss, surface run-off and groundwater use, on the basis of land (water) use maps *developed with their active involvement in plan formulation*, so that the plan is owned by the farmers to facilitate adoption and implementation in the framework of formulated rural development programmes of the government. This root definition was derived from the results of a PRA exercise conducted in the study area.

The root definitions of these two groups, one *generating the plans* and the other *using (supposed to use)* them provide an insight into the conceptual outlook of the groups regarding land use planning. This helped in identifying the different perceptions of these stakeholders in the area. Similarly, comparing the IMSD approach with the FAO approach as a 'reference' for practical implementation of land use planning programmes, highlighted the strengths and weaknesses in the current IMSD approach in a systematic way. It is pertinent to mention here that land use 'planning' as a term is used in this chapter to denote the classical top-down approach in the current IMSD methodology. On the other hand, terms such as land use analysis and land use policy formulation have been used in succeeding chapters as indicative of more participatory approaches. The analysis indicated that the IMSD programme followed the classical land evaluation (LE) approach, focusing assessment of the suitability of land for human use in agriculture, forestry or for other purposes (van Diepen et al., 1991). Widening of the scope to integrate socio-economic characteristics, leading to an integrated biophysical-socio-economic model could possibly increase its acceptability among the stakeholders. Moreover, the 'action plans' are static in nature, without options to generate alternatives or analyse the consequences of implementing suggested actions. Therefore, an interactive system that can generate what if?-scenarios as an exploratory tool could be useful for the stakeholders.

Soil conditions are considered important determinants of land use (Ravnbrog and Rubiano, 2001) and it is seen that analysing the association between soils and broad land use classes could provide a useful classification scheme for land use analysis. The hypothesis being that farmers', if they have lived long enough in an area, know the distribution of 'good soils' and the distribution of all soils of different degrees of suitability for production (Messing and Fagerström, 2001) and if the land use systems are not being practiced in accordance with the potential or the suitability of the land, these practices can be traced back to

economic conditions (FAO, 1976; Rossiter and van Wambeke, 1993). We apply this hypothesis in Chapter 3 which focuses on stratifying a study area in support of pre-field survey. We stratified the study area on the basis of soil information in three classes (Figure 7.1) (a) soil series characterized by a significant proportion of agricultural area and dominated by one cropping system (in this case rice paddy) (b) soil series characterized by a significant agricultural area with various cropping systems (c) soil series comprising largely marginal lands, characterized by a mixture of agricultural use and wastelands.

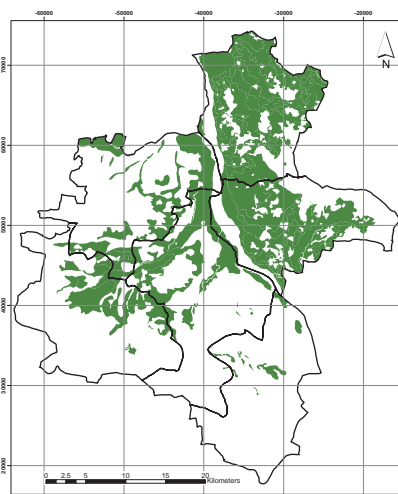

A. Crop Management Improvement

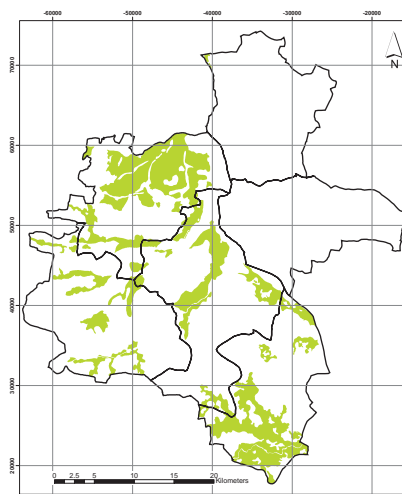

B. Crop-Selection

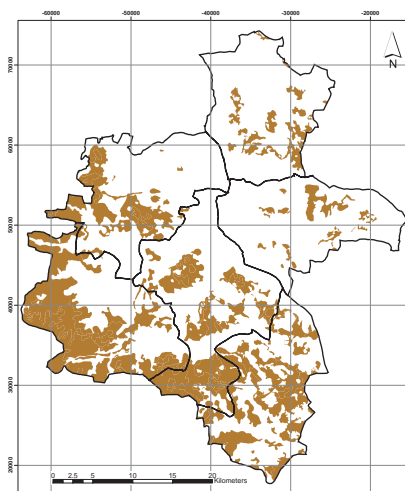

C. Conservation

Figure 7.1. Areal spread of Land use Objectives.

Group (a) areas, referred to as Crop Management Improvement areas, comprise lands where the extension agencies could focus on management issues and advise farmers on efficient use of resources for reducing yield gaps. In areas of Group (b), referred to as Crop Selection areas, the district administration and farmers could benefit from discussing the pros and cons of certain crop types based on availability of resources, such as water. A discussion support tool that could generate 'what if?'-scenarios might be useful in this situation. Group (c), Conservation areas are basically intended for conservation agriculture in some areas or non-farm activities in others. These marginal areas present a challenge to planners as they have to understand why marginal areas are cultivated by farmers and by which socio-economic driving forces farmers' decisions are affected. Options which allow farmers in these areas alternate livelihood should be explored. The stratification results have good correlations with independent sources such the District agricultural statistical data (Figure 7.2), terrain data, soil properties and field interviews with farmers.

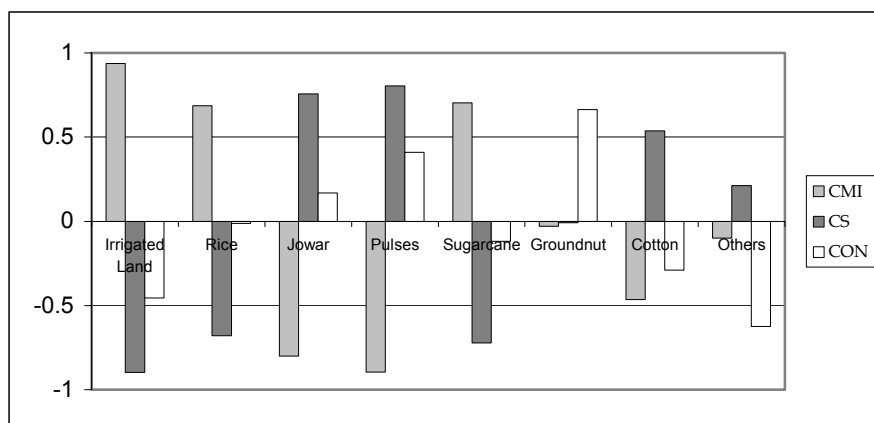

Figure 7.2. Correlations at mandal level between CMI, CS and CON areas and irrigated areas and crop types. CMI: Crop Management Improvement; CS: Crop Selection; CON: Conservation

In the present thesis, Group (a) and Group (b) areas were emphasized, while understanding was increased on issues pertaining to Group (c) areas. Since we limited this exercise to the regional scale and since actual decisions on land use planning and implementation take place at the holding level, this study should be seen as part of a pre-field support exercise and not to generate recommendations for implementation. Thus, within areas identified as part of one of the three categories, there may well be a mixture of other categories

when seen at a larger scale. The discrepancies originating from scale issues have to be discussed at holding level.

Focusing on areas identified for Crop Management Improvement (CMI), management factors that affect yield gaps in irrigated Rabi rice were studied as rice is the dominant crop in these areas. The management practices (from the date of field preparation to harvesting; 13 key variables and 76 sub-variables) of 55 farmers in the study area were analysed statistically using a multiple regression model. The yield gap of 2099 kg/ha was partitioned by the yield model to: water shortage (27%), date of harvesting (21%), second weeding (19%), inadequate groundwater yields (11%) and number of fertiliser applications (22%) (Table 7.1).

Table 7.1: Breakdown of the yield gap of Rabi rice in Kotgir and Birkur mandals by yield constraint (Kg/ha; 2001-2002 Rabi season)

| Independents | Coeff. | Measured Values | | Measured values * Coeff. | | Partial Yield Gap | Percent contribution to Yield Gap |
|--|---------|-----------------|--------|--------------------------|---------|-------------------|-----------------------------------|
| | | Avg | Best | Avg | Best | | |
| Constant | 7393.00 | 1.00 | 1.00 | 7393.00 | 7393.00 | 0.00 | |
| If no water shortage | 1169.83 | 0.51 | 1.00 | 595.44 | 1169.80 | 574.40 | 27% |
| Date of Harvesting (ref 01.01.02) | -31.88 | 107.00 | 93.00 | 3411.20 | 2964.80 | 446.32 | 21% |
| If weeding done a 2 nd time | -602.49 | 0.65 | 0.00 | -391.62 | 0.00 | 391.62 | 19% |
| Ground water yield (Litres Per Minute) | 5.44 | 157.63 | 200.00 | 857.51 | 1088.00 | 230.49 | 11% |
| With each increase in the Number of Fertiliser application (2 or 3 or 4) | 490.83 | 3.07 | 4.00 | 1506.85 | 1963.32 | 456.47 | 22% |
| Estimated Yields (Kg/ha) | | | | 6550 | 8649 | | |
| Actual Yields (Kg/ha) | | | | 6522 | 8649 | | |
| | | | | | | 2099 | |

This study highlights the issues that need attention from the planners to increase farmers' yields. Though this study was focused on rice, the method can

be applied to studying yield gaps in other crops in the area, such as sugarcane, cotton, etc. Groundwater forms the primary source for irrigation in the dry season and detailed study of groundwater could contribute to improvements in the yield model. The soil data base available for this study was ‘generic’. Detailed information on soil characteristics at field level should be incorporated in the model to further explain yield variability (at present 1:50,000 scale maps have been used). Identification of the reasons underlying the apparently low fertiliser use efficiencies warrants further study.

Building on the discussions in Chapter 2 (on developing tools for what if?-scenarios) and in Chapter 3 (on areas identified for Crop Selection), we discuss the development of the model applied for generation of what if?-scenarios for the Crop Selection areas, using Multiple Goal Linear Programming (MGLP) model (in Chapter 5). This model supports exploration of future possibilities by the district agricultural planners with participation of the farmers or farmer clubs, water user associations, agricultural scientists and extension service. The model is not intended as a planning tool, but as an aid to discussions. We generated a Stakeholder Communication Matrix (SCM) (Figure 7.3) on the basis of a detailed stakeholder analysis conducted in the study area. In this study, we propose the what if?-scenario model (MGLP) be combined with a stakeholder communication matrix (SCM), that was generated. Explicit identification of communication and information flows among various stakeholder (group)s that portray the societal dynamics in the area, is helpful in land use analysis.

| | Marginal / small scale farmer | Large scale farmer | Agric Dept | Rural Development Agency | Water Users Association | Agric Research Station / Scientists | Extension Service |
|-------------------------------------|-------------------------------|--------------------|------------|--------------------------|-------------------------|-------------------------------------|-------------------|
| Marginal / small scale farmer | - | ● | ● | ● | ● | ● | ● |
| Large scale farmer | ● | - | ● | ● | ● | ● | ● |
| Agric Dept | ● | ● | - | ● | ● | ● | ● |
| Rural Development Agency | ● | ● | ● | - | ● | ● | ● |
| Water Users Association | ● | ● | ● | ● | - | ● | ● |
| Agric Research Station / Scientists | ● | ● | ● | ● | ● | - | ● |
| Extension Service | ● | ● | ● | ● | ● | ● | - |

Figure 7.3. Stakeholder Communication Matrix

This study has highlighted that analysing the scenarios generated with the MGLP model in the context of the SCM provides insight in the interactions among stakeholders in the system, as a basis for design of 'curative' measures if required for improved communication. While the MGLP model considers the bio-economics of the land use system, the SCM describes its social aspects, which is critical for successful implementation of the MGLP model.

As discussed in Chapter 2, top-down approaches which are non-participatory are poorly accepted and adopted (FAO, 1997). Agricultural land suitability classification based on indigenous knowledge is vital to land use planning (Habarurema and Steiner, 1997; Steiner, 1998; Ryder, 2003). Indigenous knowledge when integrated with scientific methods of land evaluation becomes even more useful and this can be achieved effectively through geographical information systems (Lawas and Luning, 1996; Wandahwa and Van Ranst, 1996; Messing and Fagerström, 2001; Zurayk et al., 2001; Gonzalez, 2002; Cools et al., 2003; Oudwater and Martin, 2003). We apply a fuzzy modelling approach to capture farmers' knowledge and their criteria for land suitability identification (Chapter 6). Farmers' definitions of cropping seasons, soil properties and topographic slopes and their rules for land suitability for certain crops (Table 7.2) were the basis for fuzzy modelling.

Table 7.2: Farmers' knowledge rules of crop suitability of their land.

| RULE | IF | AND | OR | | | THEN |
|------|---------------------|--------------------|----------------|----------------|--------------------|-------|
| | Cropping season | Soil colour | Soil texture | Soil depth | Slope | Crop* |
| 1 | <i>Khariif</i> | <i>Nala Regadi</i> | Fine to M.Fine | M.Deep to Deep | Flat to Gentle | 1 |
| 2 | <i>Khariif</i> | <i>Nala Regadi</i> | Coarse | M.Deep to Deep | Gentle to Moderate | 2 |
| 3 | <i>Khariif</i> | <i>Chalka</i> | Fine to M.Fine | M.Deep to Deep | Flat to Gentle | 5 |
| 4 | <i>Khariif</i> | <i>Chalka</i> | Coarse | M.Deep to Deep | Gentle to Moderate | 6 |
| 5 | <i>Khariif+Rabi</i> | <i>Nala Regadi</i> | Fine to M.Fine | M.Deep to Deep | Flat to Gentle | 1 |
| 6 | <i>Khariif+Rabi</i> | <i>Nala Regadi</i> | Coarse | M.Deep to Deep | Gentle to Moderate | 2 |
| 7 | <i>Khariif+Rabi</i> | <i>Chalka</i> | Fine to M.Fine | M.Deep to Deep | Flat or Gentle | 7 |
| 8 | <i>Khariif+Rabi</i> | <i>Chalka</i> | Coarse | M.Deep to Deep | Flat to Gentle | 3 |
| 9 | <i>Rabi</i> | <i>Nala Regadi</i> | Fine to M.Fine | M.Deep to Deep | Flat to Gentle | 3 |
| 10 | <i>Rabi</i> | <i>Nala Regadi</i> | Coarse | M.Deep to Deep | Flat to Gentle | 4 |
| 11 | <i>Rabi</i> | <i>Chalka</i> | Fine to M.Fine | M.Deep to Deep | Flat to Gentle | 8 |
| 12 | <i>Rabi</i> | <i>Chalka</i> | Coarse | M.Deep to Deep | Gentle to Moderate | 3 |

*1 = paddy, fallow, vegetables, groundnuts; 2 = maize, turmeric, cotton,

The study explores similarities and contrasts in the way scientists and farmers perceive land suitability. Farmers' Knowledge (FK)-based suitability maps were compared with the land resources development plan – Action Plan of the IMSD project (as discussed in Chapter 2) to (a) determine degrees of similarity and (b) identify areas of agreement and conflict. Results of the study indicate usefulness of fuzzy modelling in Farmers' Knowledge-based classification of agricultural land suitability, which could provide useful information to scientists and planners and assist in understanding different perspectives that have to be taken into account in land-use analysis as a basis for land use policy formulation.

A workshop was organised in the study area in January 2004. Results of the study were discussed with the 'users', i.e. the various stakeholders to understand the utility of the present work. The District Administration, led by the District Collector and the Project Director of the District Rural Development Agency supported the workshop. The participants in the day-long research-feedback-workshop included small-scale and marginal farmers, large-scale farmers, water user associations, farm level agricultural extension officers, district-level agricultural officers, the project director of land and water management for the district, in all 25 participants from various parts of the study area. Some of the participants in the workshop also participated in the fieldwork phases of the research. We reported the results of the various studies conducted in the study area. The participants identified well with the results of the study.

Lessons learnt from this study

The study confirmed again that rural land use is a dynamic and a complex process. There are a large number of 'actors', ecological-socio-cultural-political-historical-economic driving forces that govern the way land use is organised in an area. It is very difficult to capture these complexities in models. Scientists may tend to view the issue of land use within a narrow domain of scientific knowledge (say land suitability), while farmers see it holistically in conjugation with other factors affecting their lives, such as markets, diet preferences, social customs, power relations and others.

Remote sensing- and GIS-derived biophysical data are useful in traditional land evaluation methods. However, for a practically relevant land use analysis, we should move towards integration of the biophysical data with socio-economic

interests and preferences of land users. Some methods of integration have been demonstrated in this thesis.

We have presented tools and results of our analysis to stakeholders, in the firm conviction that scientists do not make plans for them, but can support them to make their 'own' plans.

Through this study our understanding is that it is more likely that farmers and planners show interest in scientists' work if it can present alternatives and consequences of adopting a certain alternative.

We come to the conclusion based on our experiences during this study that grass root extension service is the most critical component for any successful agricultural land use analysis and its ultimate implementation. The 'plans' are as good as the extension service that implements it. This component of the district agricultural planning system has to be vastly improved in the study area with motivation, training, improved working conditions and career incentives.

References

- Checkland, P., 1992. From framework through experience to learning: the essential nature of action research. In: Bruce, C.S., Russell, A. L. (Editors), Second World Congress on Action Learning. ALARPM Ass Inc, University of Queensland, Brisbane, Australia, pp. 14-17.
- Cools, N., De Pauw, E., Deckers, J., 2003. Towards an integration of conventional land evaluation methods and farmers' soil suitability assessment: a case study in northwestern Syria. *Agriculture, Ecosystems and Environment* 95, 327-342.
- FAO., 1976. A Framework for Land Evaluation. Soils Bulletin 32. FAO. Rome.
- FAO, 1997. Participation in practice: lessons from the FAO People's Participation Programme. <http://www.fao.org/waicent/faoinfo/sustdev/PPdirect/PPre0044.htm>
- Gonzalez, R.M., 2002. Joint learning with GIS: multi-actor resource management. *Agricultural Systems* 73, 99-111.
- Habarurema, E., Steiner, K.G., 1997. Soil suitability classification by farmers in southern Rwanda. *Geoderma* 75, 75-87.
- Lawas, C.M., Luning, H.A., 1996. Farmers' knowledge and GIS. *Indigenous Knowledge and Development Monitor* 4, 8-11.

- Messing, I., Fagerström, M.H.H., 2001. Using farmers' knowledge for defining criteria for land qualities in biophysical land evaluation. *Land Degradation and Development* 12, 541-553.
- Oldeman, R.L., Hakkeling R.T.A., Sombroek, W.G., 1991. World map of the status of human-induced soil degradation. An explanatory note. ISRIC/UNEP, 34 pp.
- Oudwater, N., Martin, A., 2003. Methods and issues in exploring local knowledge of soils. *Geoderma* 111, 387-401.
- Parker, P., Letcher, R., Jakeman, A., 2002. The potential for integrated assessment and modelling to solve environmental problems: vision, capacity and direction. In: Costanza, R., Jørgensen, S.E. (Eds.), *Understanding and Solving Environmental Problems in the 21st Century. Toward a New, Integrated Hard Problem Science*. Elsevier, Amsterdam. pp. 19-39.
- Penning de Vries, F.W.T., Agus, F., Kerr, J. (Eds.), 1998. *Soil erosion at multiple scales. Principles and methods for assessing causes and impacts*. IBSRAM, Bangkok/CABI Publishing, Wallingford. 390 pp.
- Ravnborg, H.M., Rubiano, J.E., 2001. Farmers' decision making on land use - The importance of soil conditions in the case of Rio Cabuyul watershed, Colombia. *Geografisk Tidsskrift* 101, 115-130.
- Rossiter, D.G., van Wambeke, A.R., 1993. *Automated Land Evaluation System*. Cornell University. Department of Soil, Crop and Atmospheric Sciences. New York, Ithaca.
- Ryder, R., 2003. Local soil knowledge and site suitability evaluation in the Dominican Republic. *Geoderma* 111, 289-305.
- Steiner, K.G., 1998. Using farmers' knowledge of soils in making research results more relevant to field practice: experiences from Rwanda. *Agriculture, Ecosystems and Environments* 69, 191-200.
- UNCED, 1992. Agenda 21, Chapter 14, Paragraph 44, The Earth Summit, Rio de Janeiro.
- United Nations, 2002. *Report of the World Summit on Sustainable Development*. Johannesburg, South Africa, 26 August-4 September 2002.
- Van Diepen, C.A., Van Keulen, H., Wolf, J., Berkhout, J.A.A., 1991. Land evaluation: from intuition to quantification. *Advances in Soil Science* 15, 139-204.
- Wandahwa, P., Van Ranst, E., 1996. Qualitative land suitability assessment for pyrethrum cultivation in west Kenya based upon computer-captured expert knowledge and GIS. *Agriculture, Ecosystems & Environment* 56, 187-202.
- Zurayk, R., El-Awar, F., Hamadeh, S., Talhouk, S., Sayegh, C., Chenab, A.G., Al Shab, K., 2001. Using indigenous knowledge in land use investigations: a

participatory study in a semi-arid mountainous region of Lebanon.
Agriculture, Ecosystems and Environment 86, 247-262.

Resumé

Uday Bhaskar Nidumolu was born on December 2, 1969 at Gurazada in Andhra Pradesh, India. He had his 'O' & 'A' level education at St. Paul's High School and Little Flower Jr. Colleges respectively in Hyderabad and was awarded the National Merit Scholarship by the Govt of India. He graduated with a BSc (Hons) and MSc in Geology from Osmania University, Hyderabad with distinction. He then graduated with an M.Phil. in GIS and Remote Sensing from Cambridge University (Trinity Hall), UK in 1993 with a fellowship from the Cambridge Commonwealth Trust. In 1994, he started work with the National Remote Sensing Agency in India as a Scientist specialising in remote sensing and GIS applications for generating natural resources management information (as a core team scientist of the 'Integrated Mission for Sustainable Development'). He joined the PhD programme at ITC and Wageningen in March 2001 with a fellowship from the ITC which resulted in this thesis.

Uday Bhaskar Nidumolu
#A-203, Matrusri Apts.,
Hyderguda, Hyderabad, 500 029, INDIA
unidumolu@yahoo.co.in
Tel: 00-91-40-23232562; 55616029



ITC DISSERTATION LIST

1. **Akinyede**, 1990, Highway cost modelling and route selection using a geotechnical information system
2. **Pan He Ping**, 1990, 90-9003757-8, Spatial structure theory in machine vision and applications to structural and textural analysis of remotely sensed images
3. **Bocco Verdinelli, G.**, 1990, Gully erosion analysis using remote sensing and geographic information systems: a case study in Central Mexico
4. **Sharif, M.**, 1991, Composite sampling optimization for DTM in the context of GIS
5. **Drummond, J.**, 1991, Determining and processing quality parameters in geographic information systems
6. **Groten, S.**, 1991, Satellite monitoring of agro-ecosystems in the Sahel
7. **Sharifi, A.**, 1991, 90-6164-074-1, Development of an appropriate resource information system to support agricultural management at farm enterprise level
8. **Zee, D. van der**, 1991, 90-6164-075-X, Recreation studied from above: Air photo interpretation as input into land evaluation for recreation
9. **Mannaerts, C.**, 1991, 90-6164-085-7, Assessment of the transferability of laboratory rainfall-runoff and rainfall - soil loss relationships to field and catchment scales: a study in the Cape Verde Islands
10. **Ze Shen Wang**, 1991: 90-393-0333-9, An expert system for cartographic symbol design
11. **Zhou Yunxian**, 1991, 90-6164-081-4, Application of Radon transforms to the processing of airborne geophysical data
12. **Zuviria, M. de**, 1992, 90-6164-077-6, Mapping agro-topoclimates by integrating topographic, meteorological and land ecological data in a geographic information system: a case study of the Lom Sak area, North Central Thailand
13. **Westen, C. van**, 1993, 90-6164-078-4, Application of Geographic Information Systems to landslide hazard zonation
14. **Shi Wenzhong**, 1994, 90-6164-099-7, Modelling positional and thematic uncertainties in integration of remote sensing and geographic information systems
15. **Javelosa, R.**, 1994, 90-6164-086-5, Active Quaternary environments in the Philippine mobile belt
16. **Lo King-Chang**, 1994, 90-9006526-1, High Quality Automatic DEM, Digital Elevation Model Generation from Multiple Imagery
17. **Wokabi, S.**, 1994, 90-6164-102-0, Quantified land evaluation for maize yield gap analysis at three sites on the eastern slope of Mt. Kenya
18. **Rodriguez, O.**, 1995, Land Use conflicts and planning strategies in urban fringes: a case study of Western Caracas, Venezuela

-
19. **Meer, F. van der**, 1995, 90-5485-385-9, Imaging spectrometry & the Ronda peridotites
 20. **Kufoniyi, O.**, 1995, 90-6164-105-5, Spatial coincidence: automated database updating and data consistency in vector GIS
 21. **Zambezi, P.**, 1995, Geochemistry of the Nkombwa Hill carbonatite complex of Isoka District, north-east Zambia, with special emphasis on economic minerals
 22. **Woldai, T.**, 1995, The application of remote sensing to the study of the geology and structure of the Carboniferous in the Calañas area, pyrite belt, SW Spain
 23. **Verweij, P.**, 1995, 90-6164-109-8, Spatial and temporal modelling of vegetation patterns: burning and grazing in the Paramo of Los Nevados National Park, Colombia
 24. **Pohl, C.**, 1996, 90-6164-121-7, Geometric Aspects of Multisensor Image Fusion for Topographic Map Updating in the Humid Tropics
 25. **Jiang Bin**, 1996, 90-6266-128-9, Fuzzy overlay analysis and visualization in GIS
 26. **Metternicht, G.**, 1996, 90-6164-118-7, Detecting and monitoring land degradation features and processes in the Cochabamba Valleys, Bolivia. A synergistic approach
 27. **Hoanh Chu Thai**, 1996, 90-6164-120-9, Development of a Computerized Aid to Integrated Land Use Planning (CAILUP) at regional level in irrigated areas: a case study for the Quan Lo Phung Hiep region in the Mekong Delta, Vietnam
 28. **Roshannejad, A.**, 1996, 90-9009284-6, The management of spatio-temporal data in a national geographic information system
 29. **Terlien, M.**, 1996, 90-6164-115-2, Modelling Spatial and Temporal Variations in Rainfall-Triggered Landslides: the integration of hydrologic models, slope stability models and GIS for the hazard zonation of rainfall-triggered landslides with examples from Manizales, Colombia
 30. **Mahavir, J.**, 1996, 90-6164-117-9, Modelling settlement patterns for metropolitan regions: inputs from remote sensing
 31. **Al-Amir, S.**, 1996, 90-6164-116-0, Modern spatial planning practice as supported by the multi-applicable tools of remote sensing and GIS: the Syrian case
 32. **Pilouk, M.**, 1996, 90-6164-122-5, Integrated modelling for 3D GIS
 33. **Duan Zengshan**, 1996, 90-6164-123-3, Optimization modelling of a river-aquifer system with technical interventions: a case study for the Huangshui river and the coastal aquifer, Shandong, China
 34. **Man, W.H. de**, 1996, 90-9009-775-9, Surveys: informatie als norm: een verkenning van de institutionalisering van dorp - surveys in Thailand en op de Filippijnen
 35. **Vekerdy, Z.**, 1996, 90-6164-119-5, GIS-based hydrological modelling of alluvial regions: using the example of the Kisaföld, Hungary

-
36. **Pereira, Luisa**, 1996, 90-407-1385-5, A Robust and Adaptive Matching Procedure for Automatic Modelling of Terrain Relief
 37. **Fandino Lozano, M.**, 1996, 90-6164-129-2, A Framework of Ecological Evaluation oriented at the Establishment and Management of Protected Areas: a case study of the Santuario de Iguaque, Colombia
 38. **Toxopeus, B.**, 1996, 90-6164-126-8, ISM: an Interactive Spatial and temporal Modelling system as a tool in ecosystem management: with two case studies: Cibodas biosphere reserve, West Java Indonesia: Amboseli biosphere reserve, Kajiado district, Central Southern Kenya
 39. **Wang Yiman**, 1997, 90-6164-131-4, Satellite SAR imagery for topographic mapping of tidal flat areas in the Dutch Wadden Sea
 40. **Saldana-Lopez, Asunción**, 1997, 90-6164-133-0, Complexity of soils and Soilscape patterns on the southern slopes of the Ayllon Range, central Spain: a GIS assisted modelling approach
 41. **Ceccarelli, T.**, 1997, 90-6164-135-7, Towards a planning support system for communal areas in the Zambezi valley, Zimbabwe; a multi-criteria evaluation linking farm household analysis, land evaluation and geographic information systems
 42. **Peng Wanning**, 1997, 90-6164-134-9, Automated generalization in GIS
 43. **Lawas, C.**, 1997, 90-6164-137-3, The Resource Users' Knowledge, the neglected input in Land resource management: the case of the Kankanaey farmers in Benguet, Philippines
 44. **Bijker, W.**, 1997, 90-6164-139-X, Radar for rain forest: A monitoring system for land cover Change in the Colombian Amazon
 45. **Farshad, A.**, 1997, 90-6164-142-X, Analysis of integrated land and water management practices within different agricultural systems under semi-arid conditions of Iran and evaluation of their sustainability
 46. **Orlic, B.**, 1997, 90-6164-140-3, Predicting subsurface conditions for geotechnical modelling
 47. **Bishr, Y.**, 1997, 90-6164-141-1, Semantic Aspects of Interoperable GIS
 48. **Zhang Xiangmin**, 1998, 90-6164-144-6, Coal fires in Northwest China: detection, monitoring and prediction using remote sensing data
 49. **Gens, R.**, 1998, 90-6164-155-1, Quality assessment of SAR interferometric data
 50. **Turkstra, J.**, 1998, 90-6164-147-0, Urban development and geographical information: spatial and temporal patterns of urban development and land values using integrated geo-data, Villaviciencia, Colombia
 51. **Cassells, C.**, 1998, Thermal modelling of underground coal fires in northern China
 52. **Naseri, M.**, 1998, 90-6164-195-0, Characterization of Salt-affected Soils for Modelling Sustainable Land Management in Semi-arid Environment: a case study in the Gorgan Region, Northeast, Iran
 53. **Gorte B.G.H.**, 1998, 90-6164-157-8, Probabilistic Segmentation of Remotely Sensed Images

-
54. **Tegaye, Tenalem Ayenew**, 1998, 90-6164-158-6, The hydrological system of the lake district basin, central main Ethiopian rift
 55. **Wang Donggen**, 1998, 90-6864-551-7, Conjoint approaches to developing activity-based models
 56. **Bastidas de Calderon, M.**, 1998, 90-6164-193-4, Environmental fragility and vulnerability of Amazonian landscapes and ecosystems in the middle Orinoco river basin, Venezuela
 57. **Moameni, A.**, 1999, Soil quality changes under long-term wheat cultivation in the Marvdasht plain, South-Central Iran
 58. **Groenigen, J.W. van**, 1999, 90-6164-156-X, Constrained optimisation of spatial sampling: a geostatistical approach
 59. **Cheng Tao**, 1999, 90-6164-164-0, A process-oriented data model for fuzzy spatial objects
 60. **Wolski, Piotr**, 1999, 90-6164-165-9, Application of reservoir modelling to hydrotopes identified by remote sensing
 61. **Acharya, B.**, 1999, 90-6164-168-3, Forest biodiversity assessment: A spatial analysis of tree species diversity in Nepal
 62. **Akbar Abkar, Ali**, 1999, 90-6164-169-1, Likelihood-based segmentation and classification of remotely sensed images
 63. **Yanuariadi, T.**, 1999, 90-5808-082-X, Sustainable Land Allocation: GIS-based decision support for industrial forest plantation development in Indonesia
 64. **Abu Bakr, Mohamed**, 1999, 90-6164-170-5, An Integrated Agro-Economic and Agro-Ecological Framework for Land Use Planning and Policy Analysis
 65. **Eleveld, M.**, 1999, 90-6461-166-7, Exploring coastal morphodynamics of Ameland (The Netherlands) with remote sensing monitoring techniques and dynamic modelling in GIS
 66. **Yang Hong**, 1999, 90-6164-172-1, Imaging Spectrometry for Hydrocarbon Microseepage
 67. **Mainam, Félix**, 1999, 90-6164-179-9, Modelling soil erodibility in the semiarid zone of Cameroon
 68. **Bakr, Mahmoud**, 2000, 90-6164-176-4, A Stochastic Inverse-Management Approach to Groundwater Quality
 69. **Zlatanova, Z.**, 2000, 90-6164-178-0, 3D GIS for Urban Development
 70. **Ottichilo, Wilber K.**, 2000, 90-5808-197-4, Wildlife Dynamics: An Analysis of Change in the Masai Mara Ecosystem
 71. **Kaymakci, Nuri**, 2000, 90-6164-181-0, Tectono-stratigraphical Evolution of the Cankori Basin (Central Anatolia, Turkey)
 72. **Gonzalez, Rhodora**, 2000, 90-5808-246-6, Platforms and Terraces: Bridging participation and GIS in joint-learning for watershed management with the Ifugaos of the Philippines

-
73. **Schetselaar, Ernst**, 2000, 90-6164-180-2, Integrated analyses of granite-gneiss terrain from field and multisource remotely sensed data. A case study from the Canadian Shield
 74. **Mesgari, Saadi**, 2000, 90-3651-511-4, Topological Cell-Tuple Structure for Three-Dimensional Spatial Data
 75. **Bie, Cees A.J.M. de**, 2000, 90-5808-253-9, Comparative Performance Analysis of Agro-Ecosystems
 76. **Khaemba, Wilson M.**, 2000, 90-5808-280-6, Spatial Statistics for Natural Resource Management
 77. **Shrestha, Dhruba**, 2000, 90-6164-189-6, Aspects of erosion and sedimentation in the Nepalese Himalaya: highland-lowland relations
 78. **Asadi Haroni, Hooshang**, 2000, 90-6164-185-3, The Zarshuran Gold Deposit Model Applied in a Mineral Exploration GIS in Iran
 79. **Raza, Ale**, 2001, 90-3651-540-8, Object-oriented Temporal GIS for Urban Applications
 80. **Farah, Hussein**, 2001, 90-5808-331-4, Estimation of regional evaporation under different weather conditions from satellite and meteorological data. A case study in the Naivasha Basin, Kenya
 81. **Zheng, Ding**, 2001, 90-6164-190-X, A Neural - Fuzzy Approach to Linguistic Knowledge Acquisition and Assessment in Spatial Decision Making
 82. **Sahu, B.K.**, 2001, Aeromagnetism of continental areas flanking the Indian Ocean; with implications for geological correlation and reassembly of Central Gondwana
 83. **Alfestawi, Y.**, 2001, 90-6164-198-5, The structural, paleogeographical and hydrocarbon systems analysis of the Ghadamis and Murzuq Basins, West Libya, with emphasis on their relation to the intervening Al Qarqaf Arch
 84. **Liu, Xuehua**, 2001, 90-5808-496-5, Mapping and Modelling the Habitat of Giant Pandas in Foping Nature Reserve, China
 85. **Oindo, Boniface Oluoch**, 2001, 90-5808-495-7, Spatial Patterns of Species Diversity in Kenya
 86. **Carranza, Emmanuel John**, 2002, 90-6164-203-5, Geologically-constrained Mineral Potential Mapping
 87. **Rugege, Denis**, 2002, 90-5808-584-8, Regional Analysis of Maize-Based Land Use Systems for Early Warning Applications
 88. **Liu, Yaolin**, 2002, 90-5808-648-8, Categorical Database Generalization in GIS
 89. **Ogao, Patrick**, 2002, 90-6164-206-X, Exploratory Visualization of Temporal Geospatial Data using Animation
 90. **Abadi, Abdulbaset M.**, 2002, 90-6164-205-1, Tectonics of the Sirt Basin – Inferences from tectonic subsidence analysis, stress inversion and gravity modelling
 91. **Geneletti, Davide**, 2002, 90-5383-831-7, Ecological Evaluation for Environmental Impact Assessment

-
92. **Sedogo, Laurent G.**, 2002, 90-5808-751-4, Integration of Participatory Local and Regional Planning for Resources Management using Remote Sensing and GIS
 93. **Montoya, Lorena**, 2002, 90-6164-208-6, Urban Disaster Management: a case study of earthquake risk assessment in Carthago, Costa Rica
 94. **Ahmad, Mobin-ud-Din**, 2002, 90-5808-761-1, Estimation of Net Groundwater Use in Irrigated River Basins using Geo-information Techniques: A case study in Rechna Doab, Pakistan
 95. **Said, Mohammed Yahya**, 2003, 90-5808-794-8, Multiscale perspectives of species richness in East Africa
 96. **Schmidt, Karin**, 2003, 90-5808-830-8, Hyperspectral Remote Sensing of Vegetation Species Distribution in a Saltmarsh
 97. **Lopez Binnquist, Citlalli**, 2003, 90-3651-900-4, The Endurance of Mexican Amate Paper: Exploring Additional Dimensions to the Sustainable Development Concept
 98. **Huang, Zhengdong**, 2003, 90-6164-211-6, Data Integration for Urban Transport Planning
 99. **Cheng, Jianquan**, 2003, 90-6164-212-4, Modelling Spatial and Temporal Urban Growth
 100. **Campos dos Santos, Jose Laurindo**, 2003, 90-6164-214-0, A Biodiversity Information System in an Open Data/Metadatabase Architecture
 101. **Hengl, Tomislav**, 2003, 90-5808-896-0, PEDOMETRIC MAPPING, Bridging the gaps between conventional and pedometric approaches
 102. **Barrera Bassols, Narciso**, 2003, 90-6164-217-5, Symbolism, Knowledge and management of Soil and Land Resources in Indigenous Communities: Ethnopedology at Global, Regional and Local Scales
 103. **Zhan, Qingming**, 2003, 90-5808-917-7, A Hierarchical Object-Based Approach for Urban Land-Use Classification from Remote Sensing Data
 104. **Daag, Arturo S.**, 2003, 90-6164-218-3, Modelling the Erosion of Pyroclastic Flow Deposits and the Occurrences of Lahars at Mt. Pinatubo, Philippines
 105. **Bacic, Ivan**, 2003, 90-5808-902-9, Demand-driven Land Evaluation with case studies in Santa Catarina, Brazil
 106. **Murwira, Amon**, 2003, 90-5808-951-7, Scale matters! A new approach to quantify spatial heterogeneity for predicting the distribution of wildlife
 107. **Mazvimavi, Dominic**, 2003, 90-5808-950-9, Estimation of Flow Characteristics of Ungauged Catchments. A case study in Zimbabwe
 108. **Tang, Xinming**, 2004, 90-6164-220-5, Spatial Object Modelling in Fuzzy Topological Spaces with Applications to Land Cover Change
 109. **Kariuki, Patrick**, 2004, 90-6164-221-3, Spectroscopy and Swelling Soils; an integrated approach
 110. **Morales, Javier**, 2004, 90-6164-222-1, Model Driven Methodology for the Design of Geo-information Services

-
111. **Mutanga, Onesimo**, 2004, 90-5808-981-9, Hyperspectral Remote Sensing of Tropical Grass Quality and Quantity
 112. **Šliužas, Ričardas V.**, 2004, 90-6164-223-X, Managing Informal Settlements: a study using geo-information in Dar es Salaam, Tanzania
 113. **Lucieer, Arko**, 2004, 90-6164-225-6, Uncertainties in Segmentation and their Visualisation
 114. **Corsi, Fabio**, 2004, 90-8504-090-6, Applications of existing biodiversity information: Capacity to support decision-making
 115. **Tuladhar, Arbind**, 2004, 90-6164-224-8, Parcel-based Geo-information System: Concepts and Guidelines
 116. **Elzakker, Corné van**, 2004, The use of maps in the exploration of geographic data