

Farm Level Optimal Water Management: Assistant for Irrigation under Deficit (FLOW-AID)

J. Balendonck, C. Stanghellini, J. Hemming, F.L.K. Kempkes and B.A.J. Van Tuijl
Wageningen UR, Greenhouse Horticulture
Wageningen
The Netherlands

Keywords: tensiometer, wireless, sensor, crop, model, zoning, scheduler

Abstract

Flow-aid is an on-going 6th Framework European project (2006-2009) with the objective to contribute to sustainable irrigated agriculture by developing an irrigation management system that can be used for crop production in cases with limited water supply and marginal water quality. The project integrates innovative sensor technologies into a decision support system, taking into consideration boundary conditions and constraints for a number of practical growing systems in the Mediterranean. It focuses on innovative, simple and affordable, hard- and software concepts for deficit irrigation; particularly a maintenance free tensiometer, a wireless and low-power sensor network; an expert system to assist annual farm zoning and crop planning in view of expected water availability and quality; and an irrigation scheduler for allocation of water for multiple plots at farm level. The system is being evaluated at four sites located in Italy, Turkey, Lebanon and Jordan. The sites are chosen in such a way that they differ in the type of constraints, irrigation structures, crop types, water supplies (availability of amount and quality), the local goals, and their complexity. This paper describes the overall concept and briefly the progress of the first year research.

INTRODUCTION

In the developing world, water allocated to irrigation is about (or exceeds) 69% of water resources (Fry, 2005). In view of increased domestic competition for resources and the need for larger agricultural production to ensure food security, such a fraction is unsustainable. Therefore, future water security can only be warranted by a considerable increase of the water use efficiency. As a consequence, the demand for new water saving irrigation techniques is growing rapidly.

Limiting water supply may result in yield loss, whereas damage is seldom done by over-irrigation. Although crop yield is related to water use, growers often don't know the precise water requirement of crops. In most cases irrigation costs are a small fraction of total production costs, so there is little incentive for growers to save water. Thus, in practice, the irrigation amount is mostly based on the availability of water rather than the actual crop water needs.

In cases where enough water is available, growers generally face no problems. However, the availability of water strongly depends on local situations. For the mild winter climate zones, in many cases, only a limited amount of water and sometimes even of a bad quality, is available. Under these circumstances growers need to adopt deficit irrigation practices. For example, they must deal with the constraints due to sharing water within a network. A rotational schedule with a fixed duration of delivery and flow rate of water restricts what growers can do to improve water use efficiency. Further, if used carefully, lower-quality water may alleviate the need for fresh water. However, growers often do not know the effect of the use of marginal water sources on crop yield. In addition, use of low quality water is usually coupled to high leaching rates, which might lead to pollution of ground water resources.

The aim of research on irrigation techniques has shifted from "saving water" towards producing "more crop per drop" under sub-optimal or even conditions of stress for the crop commonly referred to as deficit irrigation (Lamaddalena, 2007). Currently,

we focus on monitoring systems that regularly supply information to growers about growing conditions (soil, climate and crop status) and decision support systems (DSS) with automated control that take adequate and timely irrigation or fertigation actions based upon water availability and crop needs. These technologies exist, but the main challenge is to improve the individual components, and to integrate them into one system, making the total system robust under a broad range of settings and affordable for growers.

For protected horticulture, there are several ways to obtain estimates of ET mostly based upon monitoring soil and climate based parameters combined with ET-modelling. For precision real-time irrigation control, sensors and controllers installed at each plot, or at least at every control group of sprinklers or drippers in the field, are needed to assist and tune standard ET-estimation models. Each controller performs an individual irrigation schedule which must be set and reprogrammed on a regular basis. Since many controllers and sensors are involved, the high cost for investment, installing wiring, maintenance, data-handling and use is becoming a large bottleneck, which forces growers to look for new improved and cost-effective systems. The use of wireless sensor networks saves a lot of installation and management cost (Panchard, 2006; Ning Wang et al., 2006; Kim et al., 2006; Baggio, 2005), and companies like Delta-T Devices (UK), Netafim (IS), Decagon (US) and Crossbow (US) start offering wireless sensor systems for irrigation management. However, there are still problems. Companies use different protocols and communication bands are not standardized. Equipment is still expensive and uses a lot of energy to overcome the variable damping of electro-magnetic waves in crops under fluctuating weather conditions (Thelen et al., 2005). The use of solar power instead of batteries is sometimes not useful, due to sun blocking by crop foliage. Battery operated equipment is more reliable and still favourable, which makes it needed to improve communication protocols and equipment in such a way that they become low-power and work reliably under outdoor agricultural conditions (van Tuijl et al., 2008).

FLOW-AID is an on-going project that aims to make irrigation sustainable by improving deficit irrigation practices, and by helping growers to safely, more efficiently and cost-effective manage irrigation. It aims at integrating innovative, but simple and affordable, monitoring and control technologies within an appropriate Decision Support System (DSS) (Balendonck et al., 2007; Ferentinos et al., 2003). Specifically it will develop a solid-state tensiometer based upon previous work of Whalley et al. (2007) and a wireless low power sensor network. It will improve the application of soil moisture sensors, such as the WET-sensor (Hilhorst, 2000), especially for reliable monitoring of pore water EC (Balendonck et al., 2005). It will develop a water management decision support system accessible through internet, containing an expert system to assist in long-term farm zoning and crop planning. To support on-line and short-term irrigation scheduling, a module will be developed that allocates available water among several plots and schedules irrigation for each one (Stanghellini et al., 2007; Anastasiou et al., 2008). To assist the scheduling, a crop response model will be developed and used to predict crop stress due to restricted water supply at high EC levels.

FLOW-AID focuses on the various and typical (protected as well as non-protected) growing systems found in the semi-arid regions of the Mediterranean having a mild winter climate. Testing and calibrating the system under the various local constraints of farm and basin management, helps to ensure that the technical, environmental and economical performance of irrigation systems is improved. This paper describes the overall concept and the general progress of the work during 2007.

MATERIALS AND METHODS

The system consists of several irrigation controllers, distributed over farm zones that need to be irrigated. Controllers are connected via a wireless communication link (Sownet Technologies, NL; Crossbow, US) to a local computer, which regularly reads sensor data and updates the irrigation scheduling programs running autonomously in the controllers. The system is defined in a generic way, so it may host controllers and sensors from different vendors making it applicable for a wide market. Within this work however,

we make use of the GP1 controller, WET-sensor and SM200 soil moisture sensors from Delta-T Devices (UK) as well as fertigation equipment from Spagnol Srl (IT). A Decision Support System, running on the local computer and partly on a remote computer - connected via internet - is an expert system that helps the grower to optimise the scheduler programs on a long-term as well as a short-term basis (Geomations S.A., Greece). Fig. 1 shows the system components.

Decision Support System

With respect to the long term (months or years) forecast of water availability in terms of amount, quality and timing, a DSS Farm Zoning Module based upon the MOPECO model (Ortega et al., 2004), assists the grower to divide his farm into manageable zones to make crop planting plans. The grower collects farm data like plot areas, availability of resources (water, energy, fertilizer, labour), production costs, yield response to soil water content and salinity into one crop database. Regional data may come from a central authority, where a more sophisticated version of the MOPECO model can run on a remote host, serving several farms within the river basin. In this way the grower obtains - in agreement with the characteristics of his farm - an optimised crop planting plan, a set of scheduling tasks and estimates of annual water use per plot (Dominguez, 2007).

With respect to the short term (weeks or days) availability of water, and based upon actual crop status, weather and the weather forecast (rain, radiation and temperature), a DSS Irrigation Scheduler module predicts the crop water demand. Next, for the upcoming period, it helps the farmer to select an optimal scheduling strategy and water source for each plot in terms of amount and quality. The selected and parameterized irrigation tasks are then down-loaded into the remote irrigation controllers. The irrigation scheduler is run on a day-to-day basis and checks whether new conditions give need to re-programming the controllers. The DSS does not need to be installed in full on the local computer, but can be run web-based from a remote computer as well.

To evaluate the potential crop yield under deficit conditions - and so the economic profit with respect to the used amount of water and specific water quality - the DSS will make use of an executable crop stress response model, incorporating a library containing all relevant data for crops and soil types the grower uses (Pardossi, 2008).

Irrigation Controller

To ensure that the optimal amount of water per plot is allocated, each plot has an individual irrigation controller, and sensors are added to it as needed. A typical controller will monitor relevant soil data such as volumetric water content, matric potential (Whalley et al., 2007), temperature and electrical conductivity (water quality). It can control multiple valves and water sources of distinct water quality (a well, a reservoir, reuse of water, irrigation network etc.). Once downloaded and parameterised by the DSS Irrigation Scheduler, the controller keeps on running its tasks autonomously, until it is re-programmed or stopped by the local computer. This makes the irrigation fail safe, since no real-time communication with the local computer is needed.

To be practically of use, the irrigation controllers must be rugged and affordable, have low maintenance costs and easy installation and reprogramming, use little energy, and can accommodate a wide range of sensors. To have no wiring in the field, controllers communicate with the DSS by using a wireless network. In protected cultivation, for convenience and to have lower costs, controllers might be clustered onto one larger controller implementing the individual and independent controllers virtually. Within this study we make use of the GP1-platform from Delta T Devices (UK). To save as much energy as possible, we developed a wireless sensor system using a hopping principle to relay data to the DSS via multiple sensor nodes (Balendonck et al., 2008). This system, based upon a commercially available technology (SOWnet Technologies, Delft, the Netherlands) was equipped with SM200 water content sensors (Delta-T Devices, UK) and

was tested at the Centre Sperimentale Viterbo in Pistoia (Italy) with container crops as shown in Fig. 2.

RESULTS

Correct use of irrigation water is mostly dominated by a number of local factors. Therefore, the integrated system is being tested and calibrated taking into consideration boundary conditions and constraints for a number of practical growing systems in the Mediterranean. Test-sites are chosen in such a way that they differ in the type of constraints such as soil, climatic variability, irrigation structure, crop, local water supplies (different amount and quality), production costs, local goals and their complexity.

The system is tested in Lebanon for a potato crop, using pressurized and surface irrigation (Karam, 2007). In Jordan, with the aim to make use of cleaned domestic waste water, it is tested with a dual water quality irrigation system for a soil grown tomato crop (Rusan et al., 2007). In Turkey, the system is used to prevent leaching from a soil-based cucumber greenhouse located in a preservation area near the catchment of the Tahtali dam which provides 30% of the drinking water for the city of Izmir (Tuzel et al., 2008). In Tuscany, the largest Italian region for nursery stock production of garden and ornamental plants, the system is used to control fertigation of container plants with water at high EC-levels based upon WET-sensor readings (Incrocci et al., 2008).

First results of on-going experimental work were presented in Balendonck et al. (2007). Prototypes of the soil tension sensors have shown a measurement range far wider than achieved with standard water-filled tensiometer (typically 0 to -85 kPa). First experiments with the low-power wireless sensor network showed a number of weak points regarding to operating range and robustness, the internet data-link worked perfect. The MOPECO model was improved, and extended with a salinity module that allows simulating crops behaviour under saline water conditions. The model was calibrated with data from a study in the region of Eastern Mancha (Albacete, Spain). A first version of the crop response model was built and model parameters for a number of crops were gathered, especially for tomato grown in semi-closed systems (Pardossi et al., 2008). For the DSS, a data-upload facility has been developed and tested (Anastasiou, 2008), and the general outline for the Irrigation Scheduler was defined.

DISCUSSION AND CONCLUSIONS

This paper gives a general introduction about a European project aiming at optimal water management at farm level under deficit conditions. General and intermediate results are reported, which makes it suitable to discuss the objectives of the project with irrigation scientists while the project is still on-going, and to adapt the research to the latest knowledge available in the scientific water management community.

ACKNOWLEDGEMENTS

This work is being carried out as a three year European project (036958, www.flow-aid.eu), coordinated by Wageningen University and Research Centre in the Netherlands. The authors wish to thank specifically Alberto Pardossi and Luca Incrocci based at the University of Pisa (Italy) and Paolo Marzioletti from the Centre Sperimentale Viterbo in Pistoia (Italy) for their work performed for the experiments on wireless sensors carried out at the Pistoia test-site. Furthermore we thank all researchers at Rothamsted Research (UK), University of Castilla La Mancha (Spain), Ege University Faculty of Agriculture (Turkey), Jordan University of Science and Technology and the Lebanese Agricultural Research Institute as well as the companies Delta-T Devices Ltd. (UK), Geomations S.A. (Greece) and Spagnol Srl (Italy) for their contributions to the FLOW-AID project.

Literature Cited

Anastasiou, A., Savvas, D., Pasgianos, G. Stangellini, C., Kempkes, F. and Sigrimis, N. 2008. Decision Support for Optimised Irrigation scheduling. *Acta Hort.* 807:253–258.

- Baggio, A. 2005. Wireless sensor networks in precision agriculture, In: On-line Proc. of the Workshop on Real-World Wireless Sensor Networks 2005, Stockholm.
- Balendonck, J., Bruins, M.A., Wattimena, M.R., Voogt, W. and Huys, W. 2005. WET-sensor Pore Water EC Calibration for Three Horticultural Soils. *Acta Hort.* 691:789-796.
- Balendonck, J. 2007. Farm Level Optimal Water management: Assistant for Irrigation under Deficit. 1st Executive Summary for EC Project 036958, November 12th, 2007.
- Balendonck, J., Stanghellini, C., and Hemming, J. 2007. Farm level optimal water management: Assistant for irrigation under deficit (FLOW-AID). In: *Water Saving in Mediterranean Agriculture & Future Research Needs*, Bari, Italy, 14 - 17 February, 2007 Vol. III. *Cahiers options Mediterraneennes* (pp. 301-312). N. Lamaddalena & C. Bogliotti (Eds.), CIHEAM, Bari, Italy.
- Balendonck, J., Hemming, J., van Tuijl, B., Pardossi, A., Incrocci, L. and Marzietti, P. 2008. Sensors and Wireless sensor Networks for Irrigation Management under Deficit Conditions (Flow-Aid). *Int. Conf. on Ag. Eng. 2008*, Hersonissos, Crete – Greece.
- Domínguez, A., López-Mata, E., Tarjuelo, J.M. and de Juan, J.A. 2007. Adaptación del modelo MOPECO para estimar la evolución diaria de la biomasa y del índice de área foliar. V Congr. Nac. y I Congr. Ibérico de Agroing. Sept. 2007. Albacete, Spain.
- Ferentinos, K.P., Anastasiou, A., Pasgianos, G.D., Arvanitis, K.G. and Sigrimis, N. 2003. A DSS as a tool to optimal water management in soilless cultures under saline conditions. *Acta Hort.* 609:289-296.
- Fry, A. 2005. Facts and trends, water. World Business Council for Sustainable Development, c/o Earthprint Limited, ISBN 2-940240-70-1.
- Hilhorst, M.A. 2000. A pore water conductivity sensor. *Soil Sci. Soc. Am. J.* 64(6): 1922–1925.
- Incrocci, L., Incrocci, G., Lock, G., Nicholl, C., Pardossi, A. and Balendonck, J. 2008. Calibration of the WET-sensor for volumetric water content and pore water electrical conductivity in different horticultural substrates. *Acta Hort.* 807:289–294.
- Karam, F., Lahoud, R., Masaad, R., Kabalan, R., Breidi, J., Chalita, C. and Rouphael, Y. 2007. Evapotranspiration, seed yield and water use efficiency of drip irrigated sunflower under full and deficit irrigation conditions. *Agr. Water Man.* 90: 213 – 223.
- Kim, Y., Evans, R.G., Iversen, W.M. and Pierce, F.J. 2006. Instrumentation and control for wireless sensor network for automated irrigation. ASABE paper No. 061105. St. Joseph, Mi (USA): ASABE.
- Lamaddalena N. and Bogliotti, C. 2007. *Water Saving in Mediterranean Agriculture & Future Research Needs*, Bari, Italy, 14 - 17 February, 2007 Vol. III. *Cahiers options Mediterraneennes*. Bari: CIHEAM.
- Ning Wang, Naiqian Zhang, Maohua Wang, 2006. Wireless sensors in agriculture and food industry — Recent development and future perspective. *Comp. and Electr. in Agr.* 50: 1–14.
- Ortega, J.F., De Juan, J.A., Tarjuelo, J.M. and Lopez, E. 2004. MOPECO: an economic optimization model for irrigation water management. *Irrig. Sci.* 23:61-75.
- Panchard, J., Rao, S., Prabhakar, T.V., Jamadagni, H.S. and Hubaux, J.P. 2006. COMMON-Sense Net: Improved Water Management for Resource-Poor Farmers via Sensor Networks”, ICTD 2006 Conf. in Berkeley, USA, May 25-26, 2006.
- Pardossi, A., Incrocci, L., Massa, D., Carmassi, G. and Maggini, R. 2008. The influence of fertigation strategies on water and nutrient efficiency of tomato grown in closed soilless culture with saline water. *Acta Hort.* 807:445–450.
- Rusan, M.J.M., Hinnawi, S. and Rousan, L. 2007. Long term effect of waste water irrigation of forage crops on soil and plant quality parameters. *Desalination* 215: 143–152.
- Stanghellini, C., Pardossi, A. and Sigrimis, N. 2007. What Limits the application of Wastewater and/or Closed Cycle in Horticulture? *Acta Hort.* 747:323-330.

- Thelen, J., Goense, D. and Langendoen, K. 2005. Radio wave propagation in potato fields. In: First Workshop on Wireless Network Measurements (co-located with WiOpt2005), Riva del Garda, Italy.
- Tuijl, B. van, Henten, E. van and Hemming, J. 2008. Wireless Sensor Networks: State of the Art and Future Perspective. *Acta Hort.* 801:547-555.
- Tuzel İ.H., Tuzel, Y., Meriç M.K., Öztekin, G.B., Whalley, W.R. and Lock, G. 2008. Response of cucumber to deficit irrigation. *Acta Hort.* 807:259–264.
- Whalley, W.R., Clark, L.J., Take, W.A., Bird, N.R.A., Leech, P.K., Cope, R.E. and Watts C.W. 2007. A porous-matrix sensor to measure the matric potential of soil water in the field. *Eur. J. of Soil Sci* 58: 18–25.

Figures

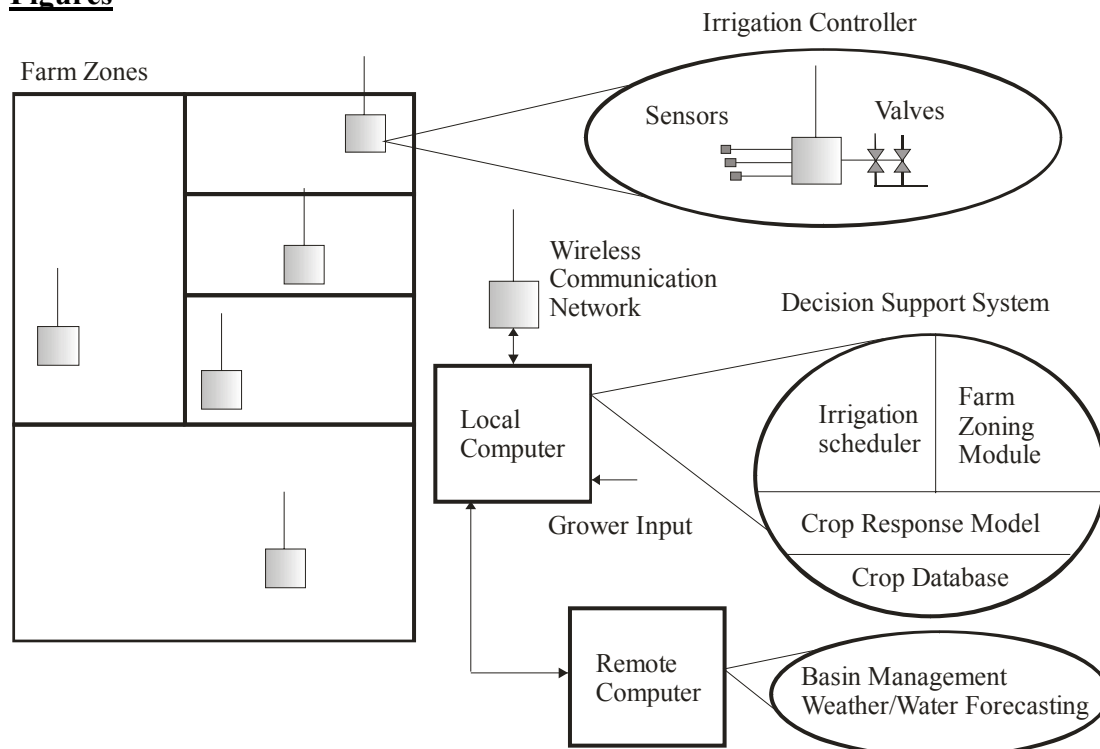

Fig. 1. Water management system for farm level irrigation under deficit irrigation.



Fig. 2. A wireless sensor node with a soil moisture sensor (SM200) operated in a 5 months experiment at Centre Sperimentale Viterbo in Pistoia (Italy).