

Watergy: Infrastructure for Process Control in a Closed Greenhouse in Semi-arid Regions

H.J.J. Janssen and Th.H. Gieling
Wageningen University & Res. Centre
Agrotechnology & Food Science Group
Wageningen
Agrotechnology and Food Innovations by
The Netherlands

S.L. Speetjens, J.D. Stigter
and G. van Straten
Wageningen University & Res. Centre
Agrotechnology & Food Science Group
Wageningen
Systems and Control Group
The Netherlands

Keywords: solar humid-air-collector, measurement and control, remote management, databases, sensor systems

Abstract

A novel solar humid-air-collector system for combined water treatment, space-cooling and –heating has been designed in an EU framework-5 financed project called Watergy. The design consists of a construction of two prototypes for applications in architecture and greenhouse horticulture: a South European variant (for arid climate and emphasis on agricultural use) and a Central/North European variant (for temperate climate and emphasis on integral building design). The core is the development of a collector system, following the principle of a closed, two phase thermo siphon. It achieves combined evaporation and –condensation, efficient heat transfer to a central heat exchanger as well as increased heat conduction from (humid) air to water. Main improvements are cost reduction in space heating and -cooling of buildings and greenhouses. Furthermore, viability increases by additional integration of greenhouse irrigation water recycling, desalination and building grey-water recycling. Sensors and actuators, connected to low-level controllers, activate a model-based control system to manage these processes.

The paper describes the different appendages, sensor systems, network connections, databases, alarming systems, user interfaces and remote management from the Netherlands to Spain through the Internet.

INTRODUCTION

Earlier Research

The Solar Power Plants in Manzanares Spain (Knapp, 1982) and Mildura Australia (Weinrebe, 2004) are solar energy projects resemble to the Watergy project. These Solar Power Plants use a tower and convert the thermal energy into electricity. In the Watergy project the thermal energy is stored and re-used for the purpose of climate control. This heating- and cooling process is combined with desalination of salt water.

The Systems in the Watergy Greenhouse

The new type of closed greenhouse, as has been developed in the Watergy project, is different from the normal commercially available greenhouses. Current commercially available climate control systems cannot fulfil the demands of this new design and cannot be easily adapted. Hence, a new control system is build up from scratch. The infrastructure to control the different processes in the novel solar humid-air-collector system consists of:

1. A heat exchanger mounted in a chimney, used for climate control of the greenhouse.
2. Storage of heating/cooling energy in three interconnected tanks forming a stratified layer.
3. Greenhouse irrigation water recycling and water recovery from salt water or grey-water by evaporation from an inner horizontal screen (inner roof).
4. The process of recycling the condensed water as clean water for the plants.

5. Control of nutrients application and of CO₂ dosing.

In a closed circuit, the air flows through the greenhouse and through the heat exchangers in the chimney. In the chimney, the air is cooled or heated, depending of the state of the system. The heating/cooling system can be represented in five states (Fig. 1). When the system is operating in the ON-state, the greenhouse is cooled during the day with cold water from a buffer tank that exchanges cold water for heated water during the day. During the night, the heated water in the buffer tank is used to heat the greenhouse.

Emergency ventilation is necessary if the temperature in the greenhouse is too high; then the air flows through the side-inlets into the greenhouse and subsequently through the tower and the opened top to the open air. If at the end of the night period the temperature of the water in the storage tanks is still too high, heat is destroyed and flushed to the open air in the same way as is done during emergency ventilation. In the idle or OFF state, the whole system stops functioning. The basic requirements for the system are:

1. The air temperature in the greenhouse should be controlled to a certain set point value
2. The cooling capacity must be used in a smart way, to avoid it being emptied before the end of the day
3. During the night, enough heat has to be taken away from the heat storage to create enough cooling capacity for the next day.

The amount of heat taken away by the heat exchanger is proportional to the water mass flow rate F_m times the temperature difference ΔT : $Q = C_p \cdot F_m \cdot \Delta T$ [W].

Assuming the tower does not contain a fan there are two variables to control: the water *flow rate* and the *inlet temperature* of the water. Initially, the water flow rate will be used to control the air temperature and the water inlet temperature will be left at a fixed value. The principle of cooling the greenhouse is represented in Fig. 2. Storage tank 1 contains the hottest water and storage tank 3 the coldest. During cooling, valve V4 selects the coldest water from storage tank 3. The valves V5, V6 or V7 select the storage tank with the average temperature T_{avg} that comes closest to the temperature of the return water of the heat exchanger T_{rm} . All other valves are closed.

Heating the greenhouse is similar to cooling, now the hottest water is used by selection of storage tank 1 by valve V1 and the return by valves V6, V7 or V8. A different set of valves reverses the water flow through the heat exchanger.

The inner roof (Fig. 4) evaporates water to cool the air and to desalinate saltwater. Especially during summertime, both functions require the evaporation to be as high as possible, leading to a continuously wet roof and frequent spraying of water. As a start, the amount of water being sprayed on the roof will be determined experimentally, leading to an ON-OFF time schedule for day and night. Initially salt water is not used yet, which prevents concern about deposits on top of the inner roof.

When the fresh/salt water is pumped to the sprinklers, one part will evaporate and another part, i.e. the inner roof drain water (IDW), will flow back to a container. The EC level controls the amount of drain water to be recirculated. The overflow of the container will carry off to the sewage system. Pump P (Fig. 4) regulates the flow in the closed water circuit. Control on de drain flow F_d will guarantee that the roof is wet. In fact, the water taken away by radiation-driven evaporation is the disturbance of the controller, a process similar to the fixed drain flow in the Hydrionline project (Gielsing et al. 2005). Control of the supply flow F_s is also a possibility. In this way, the control system allows realisation of several different strategies. Precipitation of salts in the pipes, sensors, valves, pumps and sprinklers can block the circuit. By implementing an EC limit in the EC controller precipitation will be prevented. If the water level in the container drops beneath the minimum level fresh/salt intake water will be pumped to the sprinklers. It is necessary to register all water flows to establish and maintain overall water balance. Embedded controllers perform the control of EC and flow. The local set point generator or remote models produce set point values that vary over the day-night cycle. A separate fresh water tank stores the condensate water from roof, chimney and heat exchanger.

The fertilizer & irrigation system is a standard commercial system from the Novedades Ltd firm (Xylema). Since no special measures are required, the irrigation

controller just needs to start irrigation on an external condition. The condense flows form a closed recirculating system. All water flows are registered.

The CO₂ dosing can be standard like in a normal commercial greenhouse. The Watery greenhouse is a closed system for gaseous exchanges, allowing the CO₂ level to raise to high levels. When these levels get too high, ventilation may flush CO₂ to the open air.

MATERIALS AND METHODS

Supervisory Control and Data Acquisition (SCADA)

The SCADA system (Fig. 5) supervises all the control tasks in the greenhouse. Data storage, user interfaces, models and alarm handling are located at the site in Spain but are also accessible from research sites in Wageningen and Berlin. A central real time database (Citadel from National Instruments) is the connecting link between all the simultaneous tasks and contains real time data and historical data as well. Models and user interfaces send e.g. set points to the database, from where data are immediately relayed to the corresponding tasks in the process control units. The measured and calculated data are sent back to the database. A trending task represents the data graphically and an alarming task checks the limits. Speetjens et al. (2005) describe an experimental setup with a prototype Heat Exchanger test of all chosen hard- and software components.

The experimental greenhouse location has no easy access to a suitable cable duct, so the network connection to the main building has been set up wireless (WiFi) as a cheap alternative. A preferable glass fibre connection is too expensive. Two wireless bridges of 54Mb/s, with encrypted data exchange, form a direct exclusive point-to-point connection. In the greenhouse, a Wireless Access Point connects to a local laptop, thus creating a mobile measuring system.

The control of the whole system can be sub-divided in high level, medium level and low-level control. In the high-level layer, models calculate all the set points for the low-level controllers. In the high-level layer, all heat flows, the water flows, the control of the climate and the growth of the plants is calculated for optimum performance in order to realise the main goals of the project. The medium and low-level layers realise all the set points and a basic strategy of controlling the climate in the greenhouse. (Fig. 6). When the high-level control fails, the low level control must take over automatically and realise a safe situation and an acceptable climate for the plants. The medium and low-level control executes in embedded processors (Process Control Units), the high level in the workstation or indirectly via the Internet. Every state of the greenhouse system needs its own settings of valves and pumps, which is a task of the low-level control system. A special case is the ventilation during the emergency procedure. Here, at hardware level, a thermostat opens the side inlets and the top of the chimney directly and overrules all the software controllers. Programming, designing and testing of the embedded controllers and the graphical user interface is done in LabVIEW a development system of National Instruments.

The Process Control Hardware

The low level control is executed in embedded processors (Fig. 7). The applied processors and I/O modules are of the series compact Field Point (cFP) of National Instruments. This modular system is dedicated to work in harsh industrial environments. The I/O modules connect to sensors and actuators via a patch panel. This is a standard RJ45 patch panel (Kannegieter Electronics Ltd) as used in ICT networking. The advantage being: high density and fast mounting (strip and crimp), reliable contacts, cost effective and pre-installed at Wageningen. A test box connects easily to every sensor, actuator and I/O channel allowing an individual test. The cFP, I/O modules, power supplies, patch panel and network equipment are build together in a steel cabinet and form a compact Processor Control Unit. A small built-in Uninterruptible Power Supply (UPS) improves the continuous availability of the electric power. An internal surge

arrestor suppresses spikes on the power line. Standard UTP CAT5 cabling connects all sensors and actuators to this control unit.

The temperature, CO₂ and humidity sensors are in respirated boxes and connect via a RJ45 sealed connector for easy maintenance. There are two PCU's. The first unit does a complete measurement, control and emergency handling of the greenhouse. The second unit handles all additional research measurements and is prepared to be moved to Berlin for the second part of the project.

Sensors and Actuators

Almost all analogue sensors and actuators comply with the industry standard 4-20mA. Temperature is measured with standard PT100 1/3 DIN as 4 wire RTD. Digital I/O is standard 24Vdc. These signals directly connect to the I/O modules of the compact Field Point. Non-standard sensors and actuators use local converters to meet the 4-20 mA standard.

Wet and dry bulb temperature measurements are the most accurate and long-term stable way of measuring Relative Humidity. However, filling the water container of the wet bulb sensor with distilled water is very laborious and complicated since most of the RH sensors are located on difficult reachable places in the chimney and in between the inner roof and the roof of the greenhouse so. For this reason electronic sensors of Vaisalla Finland are used. These electronic RH sensor are able to measure up to 100% RH and are not harmed by condensation since it is based on the principle of measuring the dew point. The measuring chamber needs to be mechanically ventilated because as long as the sensor is wet the measurement will be 100%. Most of the actuators for controlling valves and servomotors apply standard 24Vac & dc relay technique. Mounting the relay boxes and hard-wired circuits close to the appliances reduces costly cabling and gives more flexibility during experiments. The documentation of the whole control system is a deliverable of the Watergy project, of which a preliminary version is available (Janssen and Speetjens, 2004).

CONCLUSIONS AND PERSPECTIVES

All the main issues that were raised in the initial concept have been looked at and are realised as far as possible. The actual implementation in Spain of a central real time database functions satisfactory, it has multi-user access. It is connected locally - and remote through the Internet to embedded controllers, models and a graphical user interface. The operating system Windows XP is a single user system; this causes some inconvenience at daily practice if users want to gain simultaneously access. The development system, the real time database and the process control hardware of National Instruments form a tightly integrated system that runs robust. The programming environment is effective but has a fairly long learning trajectory. The entire ICT and process control infrastructure is ready to perform its task.

ACKNOWLEDGEMENTS

For financing the project (EU contract number NNE5-2001-683), the authors wish to thank the European Community, furthermore, the Ministry of Economic Affairs, the Ministry of Agriculture and Wageningen University and Research Centre.

Literature Cited

- Speetjens, S.L., van der Walle, T., Stigter, J.D., van Straten, G., Janssen, H.J.J. and Gieling, Th.H. 2005. Watergy, towards a closed greenhouse in semi-arid regions; a model based identification experiment. *Acta Hort.* 691:845-851.
- Gieling, Th.H., van Dijk, G.J., Janssen, H.J.J., van Ooteghem, R. and van Straten, G. 2005. Hydrion-line, towards a closed system for water and nutrients: feedback control of water and nutrients in the drain. *Acta Hort.* 691:259-266.

- Janssen, H.J.J. and Speetjens, S.L. 2004. Watergy, Control System Handbook Preliminary version. Wageningen University & Research Centre, Agrotechnology & Food Science Group, Wageningen.
- Knapp, W. 1982. Das Aufwindkraftwerk in Manzanares, Spanien; Energie Experiment im spanischen Hochland. Bild der Wissenschaft 5, p.1-12.
- Weinrebe, G. 2004. Das Aufwindkraftwerk – Wasserkraftwerk der Wüste. Nova Acta Leopoldina NF 91, Nr. 339, S.117-141 Schlaich Bergermann und Partner GmbH, Stuttgart.

Figures

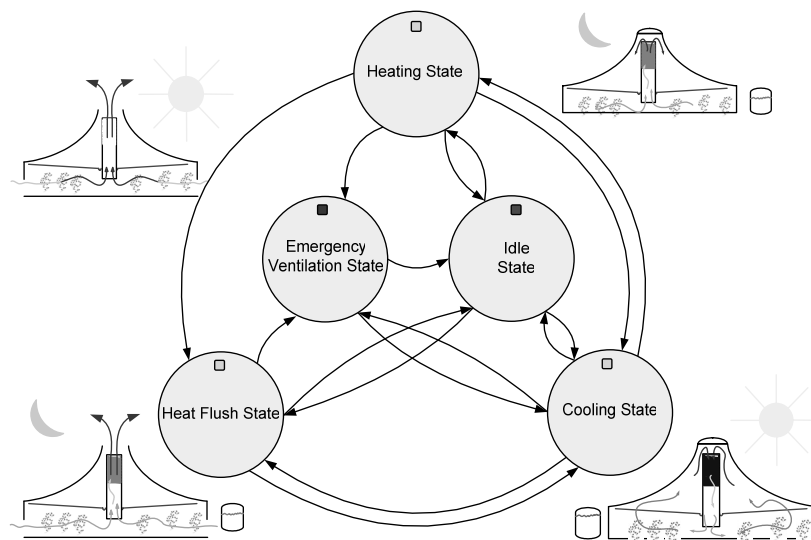

Fig. 1. State transition diagram of the Watergy greenhouse.

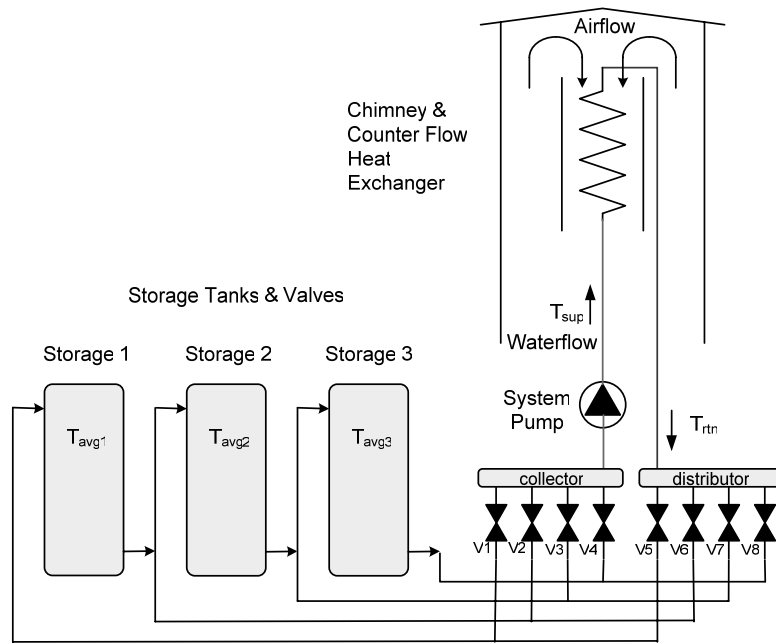

Fig. 2. Simplified diagram of the heating/cooling system.

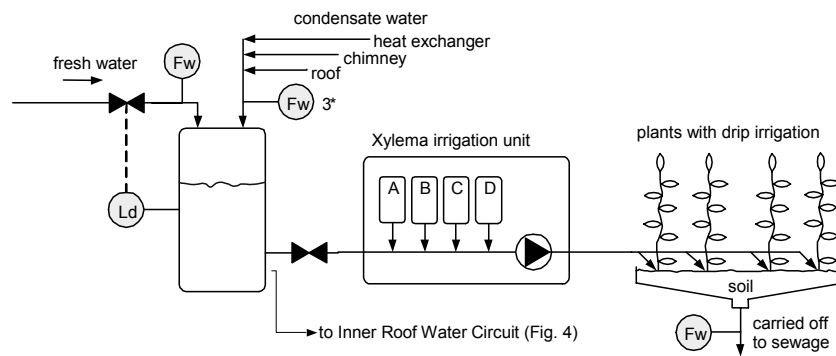

Fig. 3. The irrigation system and water circuits.

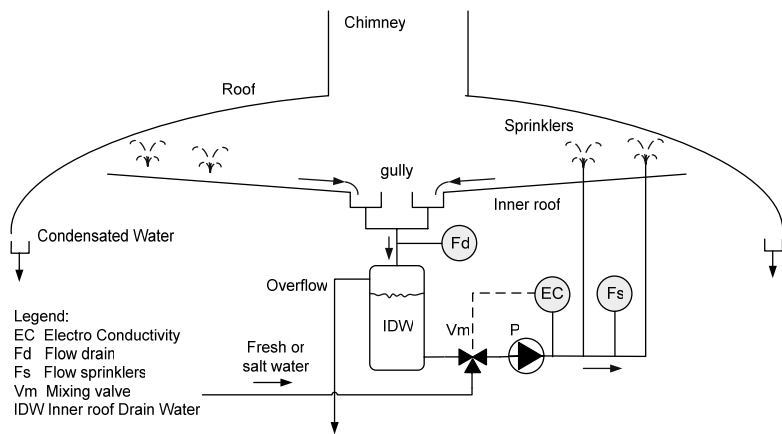

Fig. 4. Layout of the water system of the inner roof.

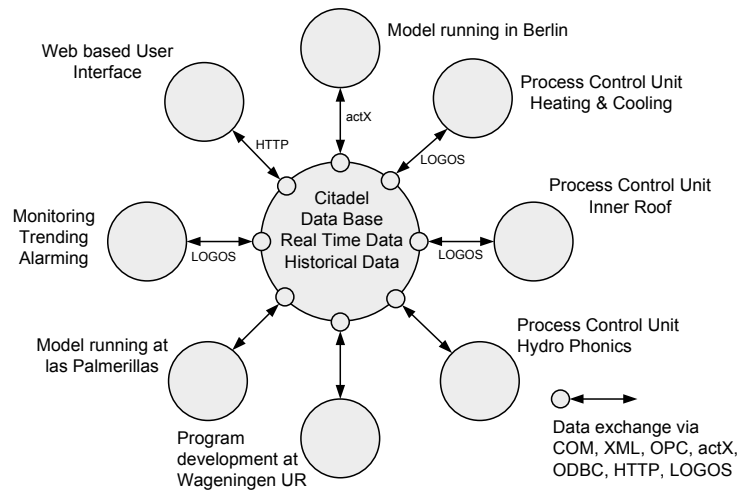

Fig. 5. Relations of all tasks to the Real Time Data Base.

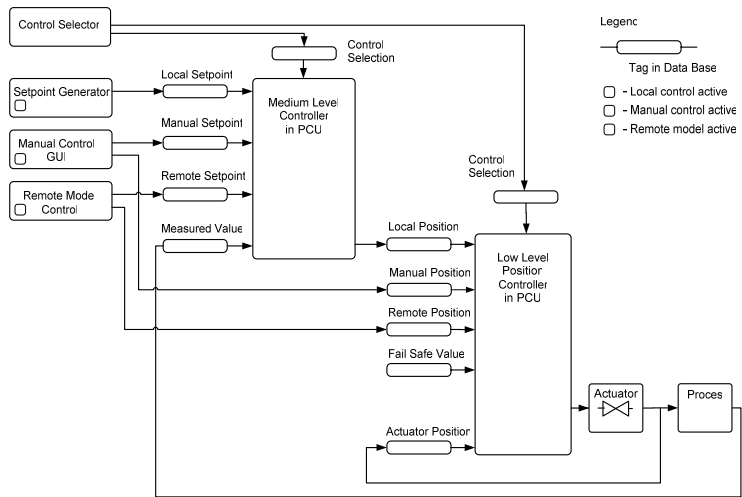

Fig. 6. The basic controller.

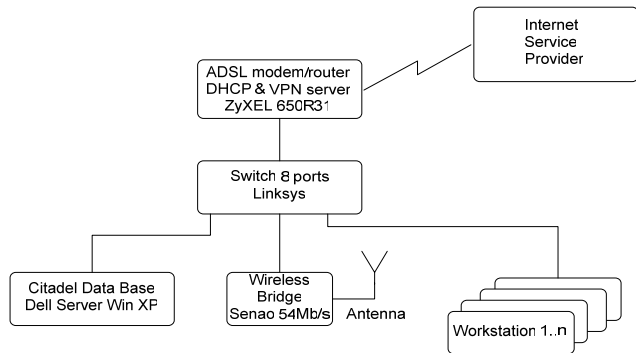

Fig. 7. ICT infra structure at the working office.

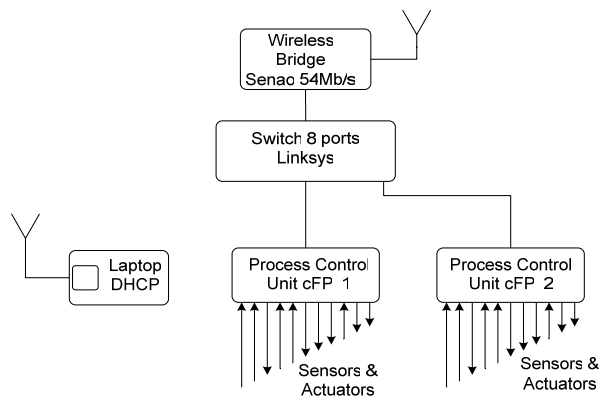

Fig. 8. ICT infra structure at the greenhouse.