

**Promotor: ir. M.M.G.R. Bol, emeritus hoogleraar in de bosbouwtechniek**

Damage-controlled logging in managed tropical rain forest  
in Suriname

40451

NN08201, 1391.

J. Hendrison

# DAMAGE-CONTROLLED LOGGING IN MANAGED TROPICAL RAIN FOREST IN SURINAME

**Proefschrift**

ter verkrijging van de graad van  
doctor in de landbouw- en milieuwetenschappen,  
op gezag van de rector magnificus,  
dr. H.C. van der Plas,  
in het openbaar te verdedigen  
op vrijdag 14 december 1990  
des namiddags te vier uur in de aula  
van de Landbouwniversiteit te Wageningen

ISBN = 268225

## ABSTRACT

Hendrison, J., 1989. **Damage-controlled logging in managed tropical rain forests in Suriname**. Doctoral thesis, Wageningen Agricultural University, The Netherlands 204 p., 44 tbs, 42 figs, 7 apps, 175 refs, Eng. and Dutch summaries. ISBN 90-9003852-3. Also published in the series **Ecology and management of tropical rain forests in Suriname**, Wageningen Agricultural University, The Netherlands. ISBN 90-800076-4-1.

As part of the CELOS Management System, which is directed to sustained yield **management** of tropical rain forests, a logging method has been developed to reduce harvesting damage **and to improve logging efficiency**. The CELOS Harvesting System includes tree enumeration, **planning and preparation** of felling operations, including establishing skid trail network before harvesting, **and using directional felling and winch extraction**.

CIP-GEGEVENS KONINKLIJKE BIBLIOTHEEK, DEN HAAG

Hendrison, J.

**Damage-controlled logging in tropical rain forests in Suriname / J. Hendrison.** - [S.l. : s.n.]. - III. Proefschrift Wageningen. - Met lit. opg. - Met samenvatting in het Nederlands. ISBN 90-9003852-3  
SISO 636.2 UDC 630(883)(043.3)  
Trefw.: bosbeheer ; Suriname / houtoogst ; Suriname / tropische regenwouden ; Suriname.

© Wageningen Agricultural University, 1990

No part of this publication, apart from bibliographic data and brief quotations in **critical** reviews, may be reproduced, re-recorded or published in any form including print photocopy, **microfilm**, electronic or electromagnetic record without written permission from the publisher, **Wageningen Agricultural University**, The Netherlands.

Cover design by Paul Woei, Paramaribo, Suriname.  
Printed by Krips BV, Meppel, The Netherlands.  
Artwork by H. Wessel and A.C.F.J. van Dortmont

BIBLIOTHEEK  
**LANDBOUWUNIVERSITEIT**  
**WAGENINGEN**

## Stellingen

1. Hoewel de ecologische randvoorwaarden voor beheer van tropische regenbossen nog onvoldoende zijn onderzocht, hoeft dit geen belemmering te zijn om voor deze bossen een systeem te ontwikkelen voor duurzame houtproductie.

Dit proefschrift

2. De opvatting van Berkhout dat een boswet pas zinvol is als effectief beheer kan worden uitgevoerd, is met betrekking tot tropische regenbossen nog steeds actueel.

A.H. Berkhout, 1917. Rapport over het Surinaamse Boswezen. Algemene Landsdrukkerij, 's-Gravenhage.

3. Hoewel het onderzoek van Schulz duidelijk aantoonde dat de bodem van het tropische regenbos in Suriname over het algemeen te arm is voor plantagebosbouw heeft het ruim 20 jaar geduurd voordat dit inzicht doorwerkte in het beleid.

J.P. Schulz, 1960. Ecological studies on rain forest in northern suriname. Noord-Hollandse Uitgevers Maatschappij, Amsterdam.

Dit proefschrift

4. Het veel toegepaste systeem van bosconcessies vormt een belemmering voor duurzaam gebruik van tropische regenbossen en dient te worden vervangen door een systeem van allocatie van gebieden voor permanente bosbouw gebaseerd op georganiseerde houtoogst en bossteeltkundige maatregelen.
5. Een boycot van tropisch hardhout op de Europese markt ter bescherming van tropische regenbossen zal verdere ontbossing en bosdegradatie niet tegengaan.

6. De instelling van een Ministerie van Bosbouw in Suriname is een voorwaarde om de bosbouw sector verder te kunnen ontwikkelen.
7. In haar streven tot relativering van haar financiële verplichtingen jegens Suriname, blijft de Nederlandse regering grote originaliteit aan de dag leggen in het bedenken van nieuwe voorwaarden voor de voortzetting van de ontwikkelingshulp.
8. De integratie van de bosbouwvakgroepen aan de Landbouwuniversiteit kan een sterke impuls geven tot vernieuwing en verdieping van het bosbouwonderwijs en onderzoek.

Dit proefschrift

9. Door de mogelijkheden die elektronische tekstverwerking biedt, worden er steeds hogere eisen gesteld aan de uiterlijke verzorging van manuscripten.

Stellingen behorende bij het proefschrift van J. Hendrison: *Damage-controlled logging in managed tropical rain forest in Suriname*.  
Wageningen, 14 december 1990.

Aan Iris en Sacha

## CURRICULUM VITAE

John Hendrison werd geboren op 17 februari 1942 te Paramaribo, Suriname. Van 1958 tot 1961 bezocht hij de Algemene Middelbare School te Paramaribo. Van 1961 tot 1968 studeerde hij Bosbouw aan de Landbouwniversiteit te Wageningen.

In april 1969 trad hij in dienst van het Landsbosbeheer (LBB) in Suriname waar hij tot 1975 eerst als houtkundige en later als project manager werkte. In die periode was hij ook actief betrokken bij het FAO/LBB project "Forestry Development in Suriname". In 1975 werd hij benoemd tot directeur van het houtverwerkingsbedrijf Surinam Timber.

Van 1978 tot 1980 werkte hij in Nederland als docent bedrijfskunde aan twee instellingen van hoger beroepsonderwijs. Daarna was hij een jaar werkzaam bij de Nederlandse Houtbond als bedrijfskundig adviseur. In 1981 trad hij in dienst van de Landbouwniversiteit te Wageningen, waar hij voor de vakgroep Bosbouw tot augustus 1984 onderzoek verrichtte in Suriname, in het kader van het project "Human interference in the tropical rain forest ecosystem". In 1986 werd hij cursusleider van de M.Sc. course Tropical Forestry van de Landbouwniversiteit. Sinds juni 1989 werkt hij in het kader van het samenswerkingsverband tussen de Landbouwniversiteit en de Gadjah Mada Universiteit als project manager van het "Forestry and Nature Conservation" project in Yogyakarta, Indonesië.



# CONTENTS

|  |           |
|--|-----------|
| PREFACE  | XI        |
| SUMMARY  | XII       |
| SAMENVATTING   | XV        |
| DEFINITION OF TERMS  | XIX       |
| <b>1 Introduction</b>  | <b>1</b>  |
| 1.1 Agents of forest degradation and deforestation                               | 2         |
| 1.2 Timber harvesting  | 2         |
| 1.2.1 Natural and human impacts  | 3         |
| 1.2.2 Significance of logging impacts  | 4         |
| 1.2.3 Logging in Suriname  | 5         |
| 1.3 Classification of logging impacts  | 6         |
| 1.3.1 Stand damage   | 8         |
| 1.3.2 Soil damage  | 10        |
| 1.3.3 Damage to the harvested product  | 11        |
| 1.4 Purpose of the present study   | 11        |
| 1.5 Applicability of damage-controlled technology                                | 13        |
| <b>2 Review of timber harvesting practices and forest management in Suriname</b> | <b>16</b> |
| 2.1 Forest exploitation before 1900  | 17        |
| 2.2 Selective logging, 1900-1947   | 18        |
| 2.3 Selective logging in managed concessions                                     | 20        |
| 2.4 Regular management   | 22        |
| 2.5 Present timber harvesting practices  | 23        |
| 2.6 CELOS Silvicultural System   | 27        |
| 2.7 Objectives of the CELOS harvesting research                                  | 29        |

|          |  |           |
|----------|--|-----------|
| <b>3</b> | <b>Research methods and site description</b>       | <b>30</b> |
| 3.1      | Logging methods                                    | 31        |
| 3.1.1    | Controlled felling                                 | 33        |
| 3.1.2    | Directional felling                                | 33        |
| 3.1.3    | Controlled skidding                                | 35        |
| 3.1.4    | Controlled winching                                | 37        |
| 3.1.5    | BSH logging  | 37        |
| 3.2      | Mapane research area                               | 38        |
| 3.2.1    | Infrastructure                                     | 39        |
| 3.2.2    | Soil and landscape                                 | 41        |
| 3.2.3    | Harvesting practices                               | 43        |
| 3.3      | Stand damage studies                               | 44        |
| 3.3.1    | Research conditions and limitations                | 44        |
| 3.3.2    | Experimental layout                                | 45        |
| 3.3.3    | Logging treatments                                 | 48        |
| 3.3.4    | Inventories  | 48        |
| 3.3.5    | Assessment and classification of felling damage    | 51        |
| 3.3.6    | Assessment of skidding damage                      | 52        |
| 3.3.7    | Assessment of wood damage                          | 53        |
| 3.4      | Soil damage studies                                | 54        |
| 3.4.1    | Test area  | 54        |
| 3.4.2    | Field and laboratory tests                         | 55        |
| 3.4.3    | Traffic intensity test                             | 56        |
| 3.5      | Logging efficiency studies                         | 56        |
| 3.5.1    | Production and time records                        | 56        |
| 3.5.2    | Felling and winching efficiency studies            | 59        |
| 3.5.3    | Efficiency of BSH logging                          | 61        |
| <b>4</b> | <b>Logging impacts to stand and harvested wood</b> | <b>62</b> |
| 4.1      | Impact of the first selective harvest              | 62        |
| 4.1.1    | Composition of the original commercial stock       | 63        |
| 4.1.2    | Assessment of felling intensity                    | 66        |
| 4.1.3    | Assessment of skidding damage                      | 68        |
| 4.1.4    | Quality of the remaining stand                     | 70        |
| 4.2      | Felling impacts of the second harvest              | 74        |
| 4.2.1    | Diagnostic significance of tree diameter           | 75        |
| 4.2.2    | Effect of felling methods on gap size              | 77        |
| 4.2.3    | Number of damaged trees in felling gaps            | 77        |
| 4.2.4    | Appraisal of factors in felling damage             | 79        |
| 4.3      | Skidding impacts of the second harvest             | 82        |
| 4.3.1    | Effect of logging systems on trail area            | 82        |
| 4.3.2    | Effect of skidding methods on tree damage          | 85        |
| 4.4      | Wood damage  | 88        |

|  |            |
|--|------------|
| 4.5 Conclusions  | 89         |
| <b>5 Skidding impacts on soil</b>                              | <b>90</b>  |
| 5.1 Soil types and rut formation                               | 92         |
| 5.2 Soil compaction and bulk density                           | 94         |
| 5.3 Soil compaction and hydraulic properties                   | 97         |
| 5.4 Soil compaction and penetration strength                   | 100        |
| 5.5 Appraisal of compaction factors                            | 101        |
| 5.5.1 Compaction factors                                       | 101        |
| 5.5.2 Long-term effects of soil compaction                     | 104        |
| 5.5.3 Conclusions  | 105        |
| <b>6 Logging efficiency</b>                                    | <b>106</b> |
| 6.1 Felling efficiency in conventional and controlled logging  | 106        |
| 6.1.1 Felling production                                       | 106        |
| 6.1.2 Felling methods  | 111        |
| 6.1.3 Effects of directional felling                           | 115        |
| 6.1.4 Other conditioning factors                               | 117        |
| 6.2 Skidding efficiency in conventional and controlled logging | 119        |
| 6.2.1 Skidding production                                      | 119        |
| 6.2.2 Impact of skidding methods                               | 121        |
| 6.2.3 Effect of the trail system                               | 124        |
| 6.3 Winching efficiency in controlled logging                  | 128        |
| 6.3.1 Winch technique  | 128        |
| 6.3.2 Effect of winching distance, cable weight, and log size  | 131        |
| 6.4 Skidding efficiency in BSH logging                         | 134        |
| 6.4.1 Operational efficiency                                   | 134        |
| 6.4.2 Skidding production                                      | 137        |
| 6.5 Conclusions  | 138        |
| <b>7 CELOS Harvesting System</b>                               | <b>141</b> |
| 7.1 CELOS Management System                                    | 141        |
| 7.1.1 Legislative requirements                                 | 143        |
| 7.1.2 The management unit                                      | 144        |
| 7.1.3 Logging intensity  | 145        |
| 7.1.4 Mechanization and workers' skill                         | 147        |
| 7.1.5 Type of venture  | 148        |
| 7.1.6 Management planning                                      | 148        |
| 7.2 CHS: prospecting and harvesting planning                   | 151        |
| 7.2.1 Prospecting  | 151        |
| 7.2.2 Compartment and site selection                           | 152        |
| 7.2.3 Skid trail design  | 152        |
| 7.2.4 Operatinal planning                                      | 153        |

|   |            |
|---|------------|
| 7.2.5 Work organization                           | 154        |
| 7.3 CHS: logging operations                       | 154        |
| 7.3.1 Trail opening                               | 155        |
| 7.3.2 Felling operations                          | 156        |
| 7.3.3 Skidding operations                         | 157        |
| 7.4 CELOS Silvicultural System                    | 159        |
| 7.5 Applicability of the CELOS Management System  | 160        |
| <b>REFERENCES</b>                                 | <b>163</b> |
| <b>APPENDICES</b>                                 | <b>173</b> |
| I Notes on Suriname                               | 173        |
| II Forest exploitation in wet lands               | 179        |
| III CELOS list of commercial species              | 182        |
| IV Inventory data and statistical tests           | 184        |
| V Results of soil tests                           | 191        |
| VI Rimpull-speed graph                            | 200        |
| VII Appraisal of commercial and potential species | 201        |

## Preface

In 1977 the Wageningen Agricultural University, the Netherlands, and the Anton de Kom University, Suriname, initiated a joint research project entitled, "Human Interference in the Tropical Rain Forest Ecosystem (project LH/UvS 01)". The project envisaged a multidisciplinary study of all aspects essential for the development of a management system for Suriname's rain forests. It encompassed silviculture, ecological, pedological and hydrological experiments conducted in the period 1978-1983. In the second half of this period, harvesting studies were incorporated in the research programme. Considerable progress had been made by the time the project was suspended in 1984; the first silvicultural experiments had been analysed and a preliminary design for the CELOS Silvicultural System (CSS) published.

The present study on damage-controlled logging in managed rain forest aimed to develop the harvesting component of the CELOS Management System (CMS), which is known as the CELOS Harvesting System. The study focussed on the impact of harvesting on the remaining stand and the forest soil and also on methods to restrict logging damage and increase logging efficiency. The experimental area was located in the Mapane forest, 100 km south-east of Paramaribo.

This study was undertaken with the help of many people. I would like to thank them all for their invaluable assistance and advice. I wish to thank the managing directors of the Suriname Forest Service (LBB), the Centre for Agricultural Research in Suriname (CELOS), the Agricultural Experimental Station (Landbouwproefstation), and the Bruynzeel Suriname Wood Company (BSH) for their support, facilities provided, and permission to run experiments in their domain.

In particular I would like to thank my promotor, Prof. M.M.G.R. Bol, for his guidance and encouragement in writing this book; Dr P. Schmidt, the team leader of the project, for reading and commenting on the manuscript; Mr J. de Vletter (LBB) for providing research facilities in Mapane forest; Mr P. Ramdhan (CELOS) for assisting me with fieldwork. Last but not least, I am grateful to Dr W.B.J. Jonkers for his inestimable support in the final stage of the study.

## Summary

Concern about worldwide deforestation and exploitation of the tropical rain forests has led to friction between national governments, wood industries and timber trade on the one hand, and scientists and environmental organizations on the other. One way to safeguard the tropical rain forests is to avoid human interference and to use forests only as nature reserves and as buffer zones of environmental protection. Some vulnerable tropical rain forests and those with unique flora and fauna should, indeed, be treated in this way. Most forests, however, have the potential to produce timber and other products on a sustainable basis provided that they are managed wisely. This study is concerned with sustained timber production of tropical rain forests, particularly with damage control during timber harvesting.

The harvesting study is part of multidisciplinary research to develop a forest management system for sustained timber production in Suriname. The research started in the 1960s on an experimental scale in the northern Forestry Belt of Suriname. At first, a monocyclic silvicultural system was chosen with the aim of converting selectively logged rain forests by silvicultural measures into stands of valuable commercial timbers in a period of 60 to 80 years (Schulz, 1960; Boerboom, 1965). The long rotation period, intensive weed control and tending of future crop trees made this system economically unattractive.

In the 1970s, a polycyclic silvicultural system was tested, envisaging timber harvests in felling cycles of 20 years by treatments of logged-over forest. This system, later known as CELOS Silvicultural System (CSS), was developed after further research (de Graaf, 1986; Poels, 1987; Jonkers, 1987). In 1981 harvesting studies were included to extend the CSS into a forest management system. Field experiments were carried out in order to compare controlled (organized) logging with conventional (unorganized, haphazardous) logging. These experiments covered damage to the remaining stand caused by felling and skidding of trees, the impact of skidding machines on the forest soil, and organizational and administrative aspects of logging.

The research was carried out mainly in Mapane region, 100 km south-east of Paramaribo (Figs 2.1 and 3.1). Conventional, commercial logging operations and controlled logging experiments were studied in a forest area of 640 ha during the period 1982-1984. A number of observations were made in an area of 100 ha,

120 km south-east of Paramaribo, in the forest estate Patamacca, of the Bruynzeel Wood Company (BSH), the largest forest concession holder in Suriname.

Felling and skidding impacts to the remaining stand were determined by mapping and calculating the affected forest area. Felling damage was assessed in terms of gaps (chablis) in the forest resulting from a felled tree, and also by the number of damaged trees per ha. Controlled felling, which includes directional felling based on a tree location map in order to facilitate skidding, was shown to reduce felling damage significantly. At a felling intensity of 8-10 trees per ha (20 m<sup>3</sup>), approximately 14% of the forest area was damaged in conventional felling compared with 8% in controlled felling. In controlled skidding, damage was restricted to 5-8% of the remaining forest, whereas in conventional skidding the affected area exceeded 14%. Skidding damage was also substantial (13%) in the organized harvesting operations of BSH, amounting to 7% due to pre-sorting operations of crawlers in the stump area and 6% due to wheeled skidding on trails.

Soil damage may result from movement of skidders. As well as rutting and disturbance to the structure, the soil may also be compacted. The type and degree of compaction are determined by soil characteristics such as structure, texture, field moisture content and organic matter content, and by characteristics of the skidders such as gross vehicle weight, steering system, and tyre and track type. Soil compaction was measured on soil samples and with the aid of a penetrometer. The soil moisture was also assessed by determining the saturated conductivity (K factor) and pF value. Subjected to intensive machine traffic, primary skid trails (main trails from stump areas to log landings), were found to be highly compacted. Most secondary branch trails (log-collecting trails in the stump areas) were compacted to some degree, depending on traffic intensity.

Trail sections with moisture content near field capacity were maximally compacted after a few round trips of the loaded skidder. Moisture content appeared to be a decisive factor in the soil degrading process. Soil recovery was a slow process, and skid trails used eight years previously were still found to be maximally compacted.

Controlled logging was found to be more efficient than conventional logging. This was examined by measuring logging production in relation to effective crew and machine time, and also by studying the suboperations in a working cycle. Measures to control felling damage were not found to have a negative effect on production. Mean felling productivity was similar for both systems, being 0.07 man-day per m<sup>3</sup> in the conventional and 0.08 man-days per m<sup>3</sup> in controlled system. On an annual basis, skidding production under the controlled system was twice that of conventional logging. This difference can be explained in terms of planning and preparation of harvesting activities undertaken in the controlled system, and also the skidding method based on a pre-established skid trail network. The controlled skidding method was more efficient as 40% less machine time was required per unit

of product transported.

The research findings provided the basis for the CELOS Harvesting System (CHS) aiming at combining logging efficiency and damage prevention. Timber harvesting is based on planning and pre-harvesting preparations, work organization and adapted logging techniques.

The cornerstone for planning is forest prospecting, that is a full (100%) enumeration of harvestable commercial trees. Prospecting data, including terrain characteristics, are mapped and recorded for the use of felling and skidding crews in searching for trees. The maps are also used to design a skid trail network for efficient terrain transport of logs from the stump area to landings along the truck roads. In this way a plan of operations can be made annually for all harvesting work.

The skid trail system should be established prior to harvesting in order to facilitate tree felling according to the skidding pattern, thus combining damage prevention and skidding efficiency. The damaging effects of skidding in the stump area can also be reduced by winching logs to the trails. The additional costs of damage prevention are compensated by overall improvement in logging efficiency.

The logging organization of a management unit is composed of one prospecting crew (5 men), one felling crew (3 men), one crawler tractor crew (2 men) and one wheeled skidder crew (2 men). This unit is supervised by an assistant manager (ranger). All field staff need to be trained in basic techniques such as tree spotting, scaling, and power saw operation to enable job rotation and thus greater flexibility in operation. Training of machine operators especially should focus on damage prevention and logging efficiency. Such an organizational unit should be able to harvest annually an area of 1000 ha.

The CELOS Harvesting System and the CELOS Silvicultural System are the subsystems of the CELOS Management System (CMS) which has been designed for a forest unit of approximately 25 000 ha. Central to this polycyclic system are the management objectives and planning for the subsystems. A major aim is restriction of logging impacts to the soil and the remaining stand. Felling intensity is restricted, for instance for Suriname to 30 m<sup>3</sup>/ha, in order to maintain the ecological, conservational, and protective functions of the forest. The present study gives guidelines for the layout of a standard management unit with a production target of at least 25 000 to 30 000 m<sup>3</sup> per year and also indicates how harvesting and silvicultural operations can be integrated. The CELOS Management System is applicable in the northern Forestry Belt of Suriname and probably in similar forest types of the Amazon basin. Timber harvesting according to this system is applicable or adaptable to most lowland tropical rain forests.



# Samenvatting

## Schadebeperkende houtoogst in het beheer van tropisch regenbos in Suriname

De verontrusting over de wereldwijde exploitatie en degradatie van tropische regenwouden heeft geleid tot een spanningsveld tussen nationale overheden, houthandel en houtindustrie enerzijds en wetenschappers en milieuorganisaties anderzijds. Sommige milieuorganisaties stellen, dat het tropische regenbos kan worden behouden, als menselijke ingrepen worden vermeden en het bos uitsluitend wordt gebruikt als natuurreservaat en als schermbos voor het milieu. Sommige kwetsbare tropische regenbossen en bossen met een unieke flora en fauna moeten inderdaad op deze wijze worden behandeld. Daarnaast kunnen de meeste bossen echter hout en andere producten op duurzame wijze leveren, vooropgesteld dat die verstandig worden geoogst.

De onderhavige studie gaat over duurzame houtproductie van tropisch regenbos, met name over schadebeperkende houtoogst. De studie maakt deel uit van een multidisciplinair onderzoek voor het ontwikkelen van een beheerssysteem voor duurzame houtproductie in Suriname. Het onderzoek begon in de zestiger jaren op experimentele schaal in de noordelijke bosgordel van Suriname. Aanvankelijk viel de keuze op een monocyclisch teeltsysteem, dat erop gericht was om selectief geoogst bos, door teeltkundige ingrepen, in een periode van 60-80 jaar om te zetten in een bos van hoogwaardige commerciële houtsoorten (Schulz, 1960; Boerboom, 1965). Door de lange omloop, intensieve onkruidbestrijding, en verzorging van waardevolle bomen bleek dit systeem economisch niet aantrekkelijk.

In de zeventiger jaren werd overgestapt op een polycyclisch teeltsysteem met als doel, om door teeltkundige behandeling van het geëxploiteerde bos in een kapcyclus van twintig jaar hout te kunnen oogsten. Dit teeltsysteem, dat later bekend werd als het CELOS Silvicultural System (CSS), werd door onderzoek verder ontwikkeld (de Graaf, 1986; Jonkers 1987; Poels, 1987). In 1981 werd begonnen met houtoogstonderzoek om CSS uit te breiden tot een bosbeheerssysteem. Experimenten werden uitgevoerd om georganiseerde houtoogst (controlled logging) te vergelijken met conventionele houtoogst (uncontrolled logging).

Het onderzoek richtte zich op vel- en uitsleepschade aan het blijvende bos, de inwerking van uitsleepmachines op de bosgrond en organisatorische en administratieve aspecten van oogstwerkzaamheden. Het onderzoek werd grotendeels uitge-

voerd in het Mapane gebied, 100 km ten zuidoosten van Paramaribo (Fig. 1.1 en 3.1). De resultaten van conventionele, commerciële bosexploitatie en experimenten met georganiseerde houtoogst werden in de periode 1982-1984 bestudeerd in een gebied van 640 ha. Enkele deelstudies vonden plaats in een gebied van 100 ha op 120 km afstand van Paramaribo in het bosbedrijf Patamacca, waar het houtoogst-systeem van de Bruynzeel Suriname Houtmaatschappij (BSH), de grootste bosconcessiehouder in Suriname, werd geanalyseerd.

Vel- en uitsleepschade aan de blijvende bosvegetatie werden bepaald door het beschadigde bosoppervlak in kaart te brengen en te berekenen. Velschade werd geschat aan de hand van de grootte van de opening ('chablis'), die door de kroon van een geveld boom in de bosvegetatie wordt geslagen en door telling van het aantal beschadigde bomen per ha. Velschade kon aanzienlijk worden verminderd door georganiseerde en gerichte velling, gebaseerd op een bomenkaart. Hierdoor werd ook de uitsleep van boomstammen vergemakkelijkt. Bij een kapintensiteit van 8-10 bomen per ha (ongeveer 20 m<sup>3</sup>/ha) werd tijdens de conventionele houtoogst 14% van het bosoppervlak beschadigd tegenover 8% bij georganiseerde velling. Bij georganiseerde uitsleep bleef het beschadigde bosoppervlak beperkt tot 5-8% van het geogste areaal, terwijl dit bij conventionele uitsleep kon oplopen tot meer dan 14%. Ook bij de georganiseerde houtoogst van BSH werd veel (13%) uitsleepschade veroorzaakt: 7% bij het voorconcentreren van stammen in de kapvlakte door rupstrekken en 6% bij verder transport met gelede wiertrekkers over sleeppaden.

Uitsleepmachines kunnen de bosbodem beschadigen. Naast insporing en verstoring van de structuur kan de bodem ook worden verdicht. Structuur, textuur, vochtgehalte en organische stofgehalte van de bosbodem en eigenschappen van de uitsleepmachines, zoals bruto gewicht, stuursysteem en het banden- of rupsentype, bepalen aard en intensiteit van de verdichting. Bodemverdichting werd gemeten aan de hand van ongestoorde ringmonsters en met behulp van een penetrograaf. Als vochteigenschappen van de grond werden de verzadigde doorlatendheid (K-waarde) en pF-waarde bepaald. Intensief bereiden primaire sleeppaden (hoofdsleeppaden, die de kapvlakte verbinden met de houtverzamelplaatsen) bleken zwaar verdicht te zijn. De meeste secundaire sleeppaden (sleeppaden in de kapvlakte) waren, afhankelijk van de intensiteit van berijding, in geringe mate verdicht.

Sleeppaden met een hoog vochtgehalte werden maximaal verdicht na enkele keren door een wiertrekker (skidder) te zijn bereiden. Vochtgehalte bleek van doorslaggevend betekenis te zijn voor het optreden van schade aan de bodem. Het onderzoek gaf ook aan dat bodemherstel een langzaam proces is. In sleeppaden die acht jaar eerder werden gebruikt, bleek de graad van verdichting nog maximaal te zijn.

Georganiseerde houtoogst (controlled logging) bleek efficiënter te zijn dan conven-

tionele houtoogst. Dit kon worden geconcludeerd door de houtproductie te relateren aan de effectieve man- en machinewerktijden en ook door de werkzaamheden in een werkcyclus te bestuderen. De schadebeperkende maatregelen bij de velling hadden geen nadelige invloed op de oogstproductie. De gemiddelde arbeidsproductiviteit van een velploeg was voor beide systemen nagenoeg gelijk, n.l. 0,07 mandag per m<sup>3</sup> voor conventionele en 0,08 mandag per m<sup>3</sup> voor georganiseerde houtoogst. Op jaarbasis gaf georganiseerde uitsleep een twee keer zo hoge produktie in vergelijking met conventionele uitsleep. Dit verschil was het gevolg van planning en voorbereiding van oogstwerkzaamheden in het georganiseerde systeem. Gedeeltelijk kan het betere resultaat ook verklaard worden door de toegepaste werkmethode, die gebaseerd was op een vooraf aangelegd sleeppadenstelsel. Georganiseerde uitsleep was doelmatiger, aangezien 40% minder machine-tijd werd besteed per eenheid getransporteerd produkt.

De onderzoeksresultaten vormen de basis van het CELOS Harvesting System (CHS), dat efficiëntie en schadepreventie combineert. Houtoogst volgens CHS is gebaseerd op planning en voorbereiding, werkorganisatie en aangepaste oogsttechnieken.

De hoeksteen voor planning is bosprospectie, een 100% inventarisatie van marktwaardige houtsoorten. Met de prospectiegegevens worden kaarten voor de kap- en uitsleepploegen samengesteld, waarop oogstbare bomen en terreinkarakteristieken zijn aangegeven. Deze gegevens worden gebruikt om de volgorde en velrichting van de te oogsten bomen aan te geven en om een sleepwegennet te ontwerpen voor doelmatig transport van geveld hout naar verzamelplaatsen aan boswegen. De houtoogst kan op deze wijze een jaar vooraf in detail worden gepland.

De werkorganisatie van een beheerseenheid is samengesteld uit een prospectieploeg (5 man), een velploeg (3 man), een rupstrekkerploeg (2 man) en een wieltrekkerploeg (2 man). Deze organisatie wordt geleid door een assistent manager (ranger). Het personeel dient een basisopleiding te hebben gehad in boomidentificatie, meetwerk en in het bedienen van een motorzaag, om afwisselend diverse werkzaamheden te kunnen verrichten (job rotation). De opleiding, in het bijzonder die van trekkerchauffeurs, moet gericht zijn op schadebeperking en efficiëntie. Een organisatie-eenheid van deze grootte moet in staat zijn om jaarlijks een areaal van 1000 ha te oogsten.

Het CELOS Harvesting System (CHS) en het CELOS Silvicultural System (CSS) zijn subsystemen van het CELOS Management System (CMS), dat ontworpen is voor een beheerseenheid van ongeveer 25.000 ha. In dit polycyclisch systeem staan de beheersdoelen en planning van de subsystemen centraal. Een hoofddoelstelling is het handhaven van de duurzame produktiecapaciteit van het bos via schadebeperking aan de bosgrond en bosvegetatie. De kapintensiteit wordt beperkt, bijvoorbeeld voor Suriname tot 30 m<sup>3</sup> per ha, om de ecologische, conserverings- en

beschermingsfuncties van het bos te behouden. De studie geeft aan hoe zo'n beheerseenheid moet worden ingericht om jaarlijks een duurzame houtoogst van tenminste 25.000-30.000 m<sup>3</sup> mogelijk te maken en hoe oogst- en teeltmaatregelen kunnen worden geïntegreerd. Het CELOS Management System is toepasbaar in de noordelijke bosgordel van Suriname en waarschijnlijk in vergelijkbare bostypen in het Amazonegebied. Houtoogst volgens CHS kan in de meeste laagland tropische regenbossen worden toegepast.

## DEFINITION OF TERMS

|                             |  |
|-----------------------------|--|
| <b>BSH</b>                  | : Bruynzeel Suriname Houtmaatschappij (Bruynzeel Suriname Wood Company)                            |
| <b>CELOS</b>                | : Centrum voor Landbouwkundig Onderzoek in Suriname (Centre for Agricultural Research in Suriname) |
| <b>CHS</b>                  | : CELOS Harvesting System  |
| <b>CMS</b>                  | : CELOS Management System  |
| <b>CSS</b>                  | : CELOS Silvicultural System   |
| <b>chablis</b>              | : an opening in the forest caused by a fallen tree   |
| <b>controlled logging</b>   | : organized timber harvesting  |
| <b>crawler</b>              | : caterpillar or crawler tractor   |
| <b>dbh</b>                  | : diameter at breast height (reference height of 1.30 m)   |
| <b>gap</b>                  | : an opening in the forest caused by a felled tree   |
| <b>LBB</b>                  | : Landsbosbeheer Suriname (Suriname Forest Service)  |
| <b>log</b>                  | : usable trunk of a felled tree  |
| <b>logging</b>              | : timber harvesting  |
| <b>power saw</b>            | : motorized chain-cutting saw  |
| <b>skidder</b>              | : articulated frame-steered 4 wheel-drive tractor  |
| <b>skid trail</b>           | : path in the forest used for log extraction   |
| <b>uncontrolled logging</b> | : conventional unmethodical timber harvesting  |
| <b>winch</b>                | : integrated component of a skidder used in log extraction   |

# 1 Introduction

There is deep concern for the future of the world's tropical rain forests. Millions of hectares of forest in South America, West and Central Africa and South-East Asia are being converted annually to other forms of land use. Forests in these areas are also exploited for timber, fuelwood and a range of products. Scientists, environmental activists, national governments and international agencies are predicting disastrous developments on a global scale, if deforestation, forest degradation and exploitation continue at the present rate (UNESCO, 1978; Gurmit Singh, 1981; Brüning, 1984; Sin Meng Srun, 1985; FAO, 1985; von Meijenfeldt, 1985; Kroachmal and Kroachmal, 1986; van Beusekom et al., 1987). The annual rate of deforestation has reached a frightening magnitude of more than 3% in many countries (Luning, 1987).

The problem is complex, involving many socio-economic factors. Circumstances differ from country to country and even within a country or region the forest is used in many different ways. There is, however, consensus on one point. A major cause of uncontrolled use and misuse of the tropical rain forest is the dependency of millions of rural people on this resource and the soil that it covers, for basic needs of food, energy and shelter. Consequently, pressure on the forest is substantially higher in densely populated countries than in those having sufficient reserves of forest and agricultural land. In this context, deforestation and forest degradation can be understood as a side-effect of population density and the struggle to survive. Land-hunger, shortage of fuelwood and urgent need for cash have become driving forces behind forest destruction and removal in many tropical countries.

The tropical rain forests are the richest and most complex terrestrial ecosystems. These unique natural resources of plant and animal species provide a wide range of products and services. The forest prevents erosion and downstream floods by absorbing and storing rainwater, and controlling run-off through networks of creeks. Minerals are recycled and fertility maintained through decomposition of organic matter and through the forest root system, which also contributes to the stability and draining capacity of the soil. It is a genetic resource and a habitat for animals. The tropical rain forest is a sensitive and dynamic system, with numerous interdependent biological and chemical processes. Any human interference may disturb the forest ecosystem, but within certain limits this flexible system has great potential to maintain and restore itself (Richards, 1964; Brüning, 1983; Jacobs et al., 1988).

## **1.1 Agents of forest degradation and deforestation**

Population pressure is not the only cause of mismanagement of forest resources. It is now agreed that, in addition to permanent agriculture and urbanization, there are four major agents of deforestation and forest degradation: shifting cultivation, pasture conversion, fuelwood gathering, and timber harvesting (Myers, 1981a; Repetto and Gillis, 1988). The present study concerns timber harvesting. Reference is made to the other three forms in order to place timber harvesting in perspective.

Shifting cultivation is one of the oldest forms of forest land use. When executed wisely with a sufficient fallow period, it can be undertaken on a sustainable basis (Boerboom and Jonkers, 1987). The common practice is to clear and burn small forest areas and to plant food crops for a few years until weed invasion and declining soil fertility makes it necessary to move to another site. In many cases increasing population pressure has reduced the length of the fallow period to less than needed to restore natural fertility.

Intensification of this form of land use is likely to lead to complete degradation of the soil. An unknown but significant area of tropical rain forest is destroyed in this way every year (Ashton, 1981). In addition, burning of the slashed forest means loss of useful raw material (wood fibres), at a rate of several hundred tonnes per hectare.

Conversion of forest to pasture for livestock production is not always appropriate on the poor soils. This process is occurring with modest success on the moderately fertile soils in Central America, but with increasing devastation in Brazil (Myers, 1981b; Poelhekke, 1984). Vast quantities of wood are burned and if this trend continues, cattle ranging will constitute a serious threat to the tropical rain forest.

Harvesting and collection of fuelwood have had serious effects on the African savannahs, and to a much lesser extent, on the tropical rain forest. Firewood is collected from logging debris or logged-over stands allocated for conversion to agriculture land. Forests are cleared for charcoal or firewood production on a limited scale (FAO, 1983), as large-scale operation is still restricted by the high cost of transport. However, the increasing demand for household fuel may exert pressure for forest clearance in the near future. As there are practically no limitations to the suitability of timber species, fuelwood and charcoal production continues to be a threat to the tropical rain forest.

## **1.2 Timber harvesting**

Commercial timber harvesting is considered to be an important agent of forest degradation. Small forest concession holders and logging companies usually organize their operations in the simplest way possible. Plans and work instructions are not prepared in advance, and harvesting starts by felling a few large trees per

hectare. Heavy machines, mainly crawler tractors or wheeled skidders, are used to collect the logs some time after felling. As tree location maps are not available, the operator has to find the logs by making trails through the forest. This type of timber harvesting, often referred to as selective logging as well as unmanaged, uncontrolled and conventional logging, is quite different from the types of land use mentioned in Section 1.1. Shifting cultivation, clear felling for charcoal and cattle ranging, remove the original forest ecosystem. Timber exploitation affects the ecosystem but does not necessarily destroy it.

Conventional timber harvesting usually has short-term objectives, such as profitable roundwood production and regular timber supply for processing plants. Like mining, conventional logging extracts the usable raw material from the resource without investment to replace it. In the past, timber exploitation in the humid tropics has usually been very light and only a few tree species have been selectively harvested. Today, logging intensity is increasing rapidly in some countries. Consequently there is a growing need for planned and organized timber harvesting for sustained yield forest management.

A substantial part of the tropical rain forests should be brought under management in order to safeguard its existence and future timber production. The present study deals with production forest as a sustainable land use. Other forms of forest land use, such as nature reserves and nature parks are not considered in the study, but it is obvious that vast areas of tropical rain forests should also be allocated for these purposes.

### *1.2.1 Natural and human impacts*

The direct result of felling a tree is a gap in the forest and an area of affected vegetation. Within certain limits, the ecological consequences of felling are similar to the natural uprooting of a tree. The process of toppling a tree, the fallen tree itself, together with the resultant hole in the canopy and accumulated debris on the forest floor is known as chablis or gap formation (Hallé et al., 1978). According to Hallé et al. (1978) and Oldeman (1983; 1987), regeneration in the tropical rain forest is induced by chablis formation and occurs in five successional phases, starting with regrowth of pioneer species and ending with the closure of the canopy by primary tree species. The area of the gap is decisive in this process of silvigenesis. A large chablis may take a longer period to recover because succession starts at the pioneer phase, while a smaller gap may be closed rapidly by the crowns of trees surviving or recovering from the felling impact.

Mechanized transport of felled trees over the forest soil has no natural equivalent. Log transport damages the vegetation and soil beyond comparison with that done by the largest herbivores inhabiting the forest or by fallen trees sliding downhill.

The key question is whether these effects are acceptable in relation to the



carrying and recuperative capacity of the forest ecosystem. How far is the forest able to fulfil its productive and regulative functions after timber harvesting? What is the relationship between logging intensity and logging impacts? In other words, can tropical rain forests be managed economically and still survive ecologically? There is no definitive answer to these questions. If, for instance, the diminished frequency of species as a result of logging leads to deterioration of the forest ecosystem, then logging is not compatible with forest conservation. However, if the forest maintain its productive, regulative and ecological functions at approximately the same level, then such interference is acceptable because the stability of the forest ecosystem has not been affected significantly. This study aims to contribute to the development of such a system by examining ways of reducing damage by planning and modified logging techniques.

### *1.2.2 Significance of logging impacts*

The measurable effects of timber harvesting on forest health and ecological stability differ from place to place according to logging intensity and prevailing physical, biological and socio-economic conditions. The present role of logging may be summarized as follows:

- Most tropical rain forests are only lightly exploited for a few commercial timber species, and thus the original forest is slightly modified by selective felling of desirable timber species. According to Estève (1983), the economic value of the forest might decrease with the depletion of the commercial stock, but the ecological value remains largely unchanged.
- The effects on forest ecosystems and downstream areas are directly related to the mode and intensity of logging operations. The uncontrolled harvesting of Dipterocarp forests in South-East Asia of volumes up to 150 m<sup>3</sup>/ha has led to serious erosion, water pollution and drastic changes in species composition and forest structure (Tinal and Palenewen, 1974; BIOTROP, 1978; Nicholson, 1979; Kasran, 1989), doing irreversible damage. Selective logging of lowland rain forests in Suriname has only locally caused light environmental disturbance, but forest clearing for plantation forestry has led to degradation of soil fertility (Boxman, in press).
- Full use of timber stock, that is harvest of all timber species or biomass harvest, is threatening the tropical rain forest in some places. The technology is available to use a wide range of tropical timber species for pulp and paper production, charcoal and fibre board, but processes are still expensive and not as yet economically feasible. The Jari project in Brazil (Hornick et al., 1984), Cel-lucam in Cameroon and Carton de Colombia in Colombia (Barrera, 1987) are examples of commercial fibre use from mixed tropical timber.

There is a tendency to exaggerate the damaging impact of timber harvesting. "It has become almost a normal attitude, to put the blame for forest destruction in logging, for degrading the health of our forests, on the shoulders of forest operations and technology" (Bol, 1985). Low intensity selective logging ('light creaming'), which is still widely practised in tropical rain forests, is one of the least destructive land use systems. However, the road network for these activities opens up the forest to invasion by farmers and other settlers. Often only a narrow strip along access roads is used intensively, while more extended settlement is only possible in regions having some service facilities. Abandoned, logged-over rain forests become less accessible as the road system deteriorates, and less attractive for settlement. Where population pressure is high, forest colonization may occur without an established road system. In such cases, hunger and poverty are apparently stronger deforestating agents than logging operations.

The fast growth of wood-based industries in tropical countries (ADB, 1987) may lead to forest degradation. Both the logging industry and national governments need to accept responsibility for protecting and improving this potentially renewable resource. Timber harvesting should not be an activity on its own but be integrated with silviculture in one forest management system.

### *1.2.3 Logging in Suriname*

Suriname is a thinly populated country with relatively few problems with deforestation. Yet, there are numerous examples of misuse of forest land, forest fires and uncontrolled timber harvesting (Gonggrijp and Burger, 1948; Bubberman, 1973; Tjon Lim Sang, in press). For centuries, the Amerindians and Bushnegroes have practised a system of shifting cultivation allowing forest lands to recover during fallow periods of 20 to 30 years. In the past few decades, shifting cultivation along forest roads has grown almost simultaneously with the road building programme. The fact that most of the country is still covered with pristine forest is not the result of wise management but rather of restricted use, difficult access, and sparse habitation.

Timber harvesting is not an agent of large-scale forest degradation in Suriname. Nevertheless, logging operations have had an impact on the forest environment. Use of logging machinery has also increased damage to stand and soil in some places. Timber harvesting can no longer be considered to be a light forest creaming followed by a recovery period for regrowth of desirable species. It has become a capital-intensive operation, the cost of which has to be recovered by raising output. Accessible natural forest are under pressure to yield a maximum quantity of usable wood. Although logging intensities in Suriname are still relatively low, the emphasis on maximizing production is a potential threat to the forest.

The exploitable forest belt or Forestry Belt in the northern rain forest zone of Suriname is accessible through a forest road network (see Fig. 1.1 and Appendix I).

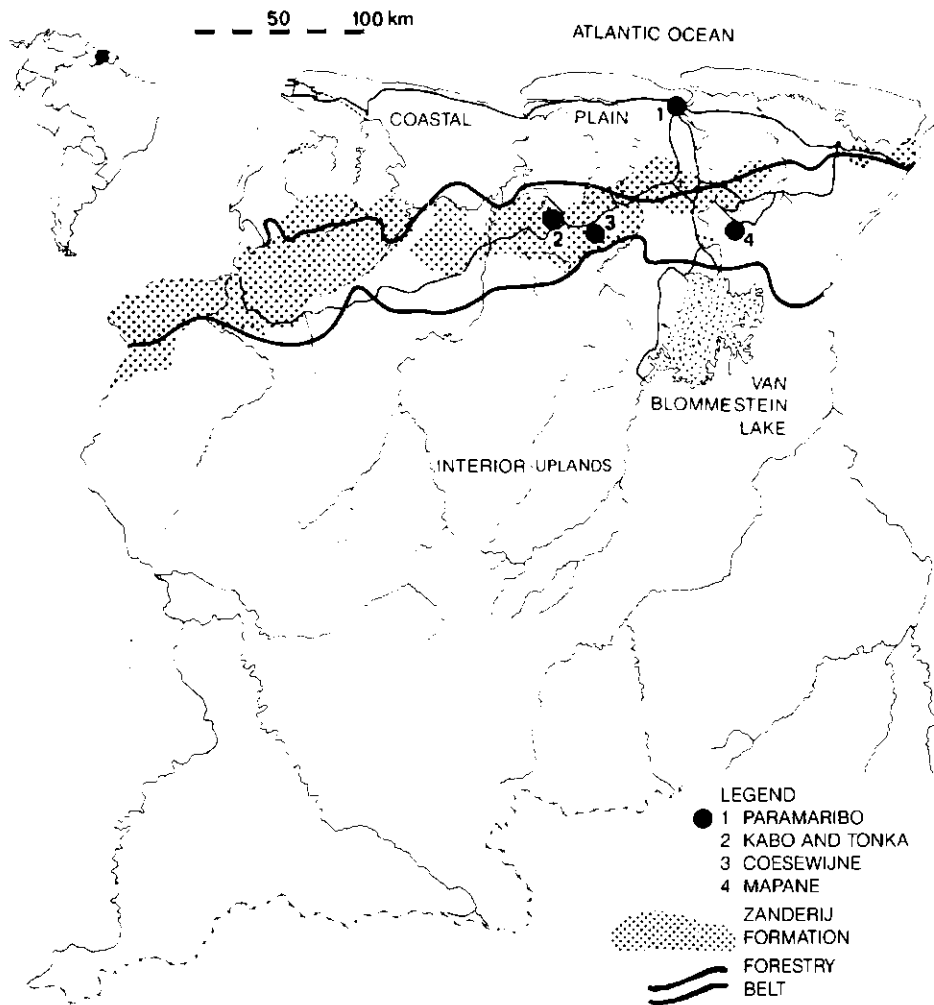


Fig. 1.1 Map of Suriname

Almost 90% of timber production is from this zone and all regular forestry activities, including tree plantations, occur there (Hendriksen and Jonkers, in press). Field work for the present and related studies (de Graaf, 1986; Jonkers, 1987; Poels; 1987) was also conducted in the Forestry Belt.

### 1.3 Classification of logging impacts

The reversible and virtually irreversible impacts of timber harvesting on a forest ecosystem can be presented in an analytic model (see Table 1.1), which is based on

TABLE 1.1. Impacts of logging operations

| Logging operations       | Stress factors                                | (Sub)system affected                 | Elastic strain                              | Plastic strain   |
|--------------------------|---|--------------------------------------|---|--|
| Felling                  | falling tree, lianas                          | forest ecosystem                     | species loss, structural disturbance, pests | cleared forest, large gaps                               |
|                          |   | individual trees                     | crown and bark damage, disease              | uprooting, crown and bark injury, wood rot               |
|                          |   | saplings, seedlings, other organisms | disturbance                                 | destruction, injuries                                    |
| Skidding, (yarding)      | wheel/track action, sliding and sweeping logs | forest ecosystem                     | structural disturbance                      | cleared forest   |
|                          |   | individual trees                     | bark damage                                 | uprooting, bark injury, root injury                      |
|                          |   | saplings, seedlings, other organisms | disturbance                                 | destruction, injuries                                    |
|                          |   | soil                                 | structural disturbance                      | structural degrading, erosion, compaction, nutrient loss |
| Log handling and storing | mechanical handling, storing period           | logs                                 |   | breaking, splitting, wood rot, insect attack             |
| forest road making       | machinery action                              | forest ecosystem                     |   | cleared forest   |
|                          |   | soil                                 |   | compaction, erosion                                      |

the stress-strain concept used by Ulrich (1983) to explain effects of acid deposition on forest ecosystem stability. Stress on a system results in strain within the system. This strain may be elastic (reversible) or plastic (long lasting). Plastic strain implies that some properties of the system have changed durably, either invisibly (latent) or visibly. Visible plastic strain is usually called injury (Ulrich, 1983; also see Levitt, 1980). In this study this model is used as a reference for the terminology related to logging damage.

Timber harvesting is a collective term for the set of operations commencing by opening up the forest and ending with transporting logs from landings. Each operation may affect several components of the forest ecosystem vegetation, fauna, soil, water and air. Consequently, the type of damage is described as vegetation damage, soil erosion, soil compaction, or water pollution. A component consists of a number of subsystems, each being subjected to stress or destruction. For instance, vegetation damage includes not only trees but also damage to saplings, seedlings, palms and other plant components; the larger the plant, the more visible the damage pattern. A large tree may be uprooted, broken or split, the crown partly destroyed, or the trunk debarked. Damage referring to the organs or elements of a tree is called crown, bark or root damage.

A damaged tree crown may regain its original assimilation capacity, and is, therefore, an example of elastic strain. Small cambium wounds on the stem may recover within a few months. The slow recovery process of compacted soils can be accelerated by the activity of fauna and microorganisms. This type of strain can be considered as plastic. The following examples are also classified as plastic strain. The forest ecosystem as a whole may degrade towards a new equilibrium on a lower level, resulting in a less luxurious forest, fewer timber species and decreased nutrient stock. Uprooted trees or trees with destroyed crowns are not "reparable". Even if they survive, the same ecological function is never regained. Heavily eroded soils on hill slopes should be considered as site loss.

Not all possible stress-strain interactions are classified as plastic strain in Table 1.1. For instance, the impact of road construction on subsystems (trees and soil) has not been detailed. This is a one-off operation and the loss of a relatively small proportion of forest area is accepted as the price for opening up the forest.

The present study concentrates on soil and stand damage caused by felling and skidding operations. Effects, such as loss of nutrients and plant species, are covered in other studies (see Section 1.4).

### *1.3.1 Stand damage*

*Felling intensity.* The visible damage done to the surrounding vegetation by felling even of a single tree is obvious. A large emergent tree may form a felling gap of a few hundred square metres in which small trees and numerous saplings and seedlings are destroyed. While damage in the immediate vicinity of a felled tree is

obvious from the ground (Fig. 1.2), aerial photographs of selectively logged forest may show such gaps as moderate interruptions to the vegetation cover (see Fig. 4.4 and Jonkers, 1987). The extent of damage is largely determined by the felling intensity, that is the number or volume of trees felled per hectare.

Every felled tree damages the surrounding vegetation to some extent. Consequently, intensive felling of large trees greatly affects forest dynamics. However, the allowable felling intensity cannot be determined without knowledge of ecological processes in both undisturbed and disturbed forest.

A gap has been described as an open space in the forest, partly occupied by the crown and trunk of a felled tree (see Section 1.2). A number of factors may influence the frequency, size and shape of felling gaps, such as forest composition, spatial distribution of trees, occurrence of vines and woody climbers, and gregariousness of desirable species. When tree crowns are linked by lianas, a felled tree can easily damage neighbouring trees and may even uproot them. Large open spaces may appear in the forest vegetation as a result of the chain effect of falling trees (Fox, 1968; Putz, 1984).

Observation of gap formation during felling gives the impression that this is largely an uncontrollable process. Sound, mature commercial trees are generally large, and when felled, their bulky crowns usually determine the architecture of the chablis. At present no economically feasible means are available to prevent or restrict felling damage and gap formation.



Fig. 1.2 Gap formation

Increased light intensity and temperature in gaps accelerates most biological and biochemical processes (Schulz, 1960). In natural gaps (chablis) these processes are in balance with the stability of the ecosystem. Felling gaps expose part of the forest floor to the macroclimate. Disturbance of recycling processes may result in a loss of nutrients liberated through accelerated decomposition of organic matter (Poels, 1987; Schmidt, in press). Moreover, the stimulated growth of secondary species, lianas and climbers, will produce significant local changes in the forest structure. Logging intensities of 60 - 80 m<sup>3</sup>/ha in the Dipterocarp forests of Indonesia and Malaysia have adversely affected regeneration, hydrology and environmental stability (BIOTROP, 1978). Such felling intensities will evidently deplete the production capacity of soils and trees of commercial species.

An acceptable level of timber harvesting is difficult to define (Vooren, 1987). It is easier to analyse destructive felling intensities than to determine the critical level for safe harvesting operations. A felling intensity of five to eight trees per hectare is considered to be sustainable for most types of tropical rain forests (Boerboom and Wiersum, 1983). The problem of an allowable felling intensity is also examined in the present study.

*Skidding.* After felling, trees have to be extracted from the stump area to a landing along a truck road for further transport. For this type of terrain transport, wheeled skidders and crawler tractors are widely used in lowland rain forest conditions. Skidding operations always affect the soil and forest vegetation. Firstly, there is the effect of the trail network which is part of the infrastructure of the logging area. The network comprises primary trails giving access to a section of the forest (logging compartment) and secondary or branch trails connecting the trees in the stump area.

The forest vegetation has to be cleared for the trail network. The amount of damage done in this operation will depend on the proposed logging intensity, and the planned organization of the harvesting work. A well designed and efficient trail system should not be regarded as stand damage but as a permanent part of the forest infrastructure to be used in future harvests. Removal of forest vegetation in the stump area, damage to bark and root systems of standing trees during log collection is largely unnecessary and should be considered to be stand damage.

### *1.3.2 Soil damage*

The use of heavy mobile equipment in log extraction induces complex physical and mechanical processes in the forest soil. The visible effects are ruts or tracks formed by machine wheels and crawler tracks and by the transported load. The extent of the damage is not only determined by the equipment itself but also by the management system, soil characteristics and weather conditions.

Soil strength and bearing capacity for machines is determined by texture,

structure, density, moisture content, organic matter content of the soil as well as the rooting pattern of trees. Gross weight, wheel or track type as well as speed and steering characteristics of machinery are also important factors (Soane et al., 1981a; 1981b; Koolen and Kuipers, 1983; Beekman, 1987).

Soil compaction resulting from the use of heavy equipment is a serious problem. Loamy soils under wet conditions are more susceptible to compaction than sandy soils or soils of more stable structure. The top organic layer is rapidly removed by the rolling skidder wheels, and the soil under the wheels or tracks and the load is subjected to considerable physical forces. The soil moisture content and number of passes largely determine the degree of compaction (Moehring and Rawls, 1970). Primary trails designed to serve an entire logging compartment throughout the harvest are usually heavily compacted. Such trails may be exhausted rapidly, if deep tracks hamper machine movement. A second trail is then needed parallel to the first, thus extending the affected area. Deep tracks in the soft soil of creek crossings make further skidder movement impossible after only a few round trips.

The porosity and water penetration capacity of soils are considerably reduced by compaction. Root penetration is retarded thus slowing down vegetation growth. Compacted soils, therefore, regenerate slowly and the effects may persist for 40 years or more (Erdas, 1976). In hilly areas soil compaction may promote erosion as rainwater cannot penetrate the soil fast enough.

The high moisture content in the tropical soils makes soil damage a serious consideration in management systems for sustained timber production. A logical step would be to minimize skidder movements and to concentrate activities on the main trail (Froehlich et al., 1981; Queensland Department of Forestry, 1983). Planning and design of skid trail systems aimed to restrict soil damage is, therefore, included in the present study.

### *1.3.3 Damage to the harvested product*

Poor working methods and techniques during felling and terrain transport lead to splitting and breaking of felled trees. Wood damage, involving serious loss of quality, can occur during positioning and collecting (bunching) of logs with the blade of a skidder. This is an indirect loss of forest area and thus an aspect of logging damage. In addition, logs may deteriorate during storage in the forest and at roadside or river landing. Both aspects of damage are examined in the present study.

## **1.4 Purpose of the present study**

Approximately 80% of Suriname is still covered with tropical rain forest. Since the



Suriname Forest Service was established in 1947, the forestry sector has developed rapidly. In the early 1960s wood products became the third export commodity after bauxite and agricultural products. Yet today, the economic importance of the forestry sector is still modest and contributes no more than 3% of the gross domestic product, of employment and of foreign trade (Appendix I).

Various attempts were made to increase forestry production by improving forest management, logging operations and wood processing. After a period in which emphasis was on establishing plantations of fast growing timber species, the policy changed to investigation of natural forest regeneration after logging. Various studies in natural regeneration have been executed by the Suriname Forest Service and since 1965, by the Centre of Agricultural Research in Suriname (CELOS). A number of experiments were carried out to find a regeneration technique for lightly exploited forests. The basic objective was to promote growth of commercial timber species by eliminating part of the competing vegetation (de Graaf and Geerts, 1976). The results were so promising that the Wageningen Agricultural University, the Netherlands, and the Anton de Kom University, Suriname, initiated a joint research project in 1977 entitled 'Human Interference in the Tropical Rain Forest Ecosystem (project LH/UvS 01)'.

The project envisaged a multidisciplinary study of all relevant aspects necessary for the development of a management system for Suriname's rain forests. In addition to silvicultural research, ecological, pedological and hydrological experiments were conducted in the period 1978 - 1983. In the first half of this period, it was concluded that a forest management system could not be developed without an appropriate, well adapted logging system. In 1981 the research programme was extended with harvesting studies.

Considerable progress had been made by the time the project was suspended in 1984. The first silvicultural experiments had been analysed and a preliminary design for the CELOS Silvicultural System (CSS) published (de Graaf, 1982; 1983; 1986; Jonkers and Schmidt, 1984). After 1980, the CSS was developed into a more comprehensive silvicultural system (Jonkers, 1987). Basic research on hydrological and nutrient aspects has been completed (Poels, 1987) as well as on ecological aspects (Schmidt, in press). The project also included studies on the nutrient status of pine plantations (Boxman, in press) and on aspects of secondary succession on deforested land (Tjon Lim Sang, in press).

The present study on damage-controlled logging in managed rain forest is part of this programme, and aimed to develop the harvesting component of the CELOS Management System (CMS). This component is known as the CELOS Harvesting System (Boxman et al., 1985; 1987; de Graaf and Hendrison, 1987; Jonkers and Hendrison, 1987; Hendrison and Jonkers, in press). The study concentrates on harvesting impacts to the remaining stand and the forest soil as well as on methods to restrict logging damage, and to increase logging efficiency. The latter is essential because damage-controlled logging will only be practised by commercial companies if it is also economically attractive. Therefore much attention is given to the

efficiency and costs aspects of the controlled logging methods examined.

Harvesting impacts of both conventional and controlled logging were examined with respect to vegetation and soil damage of the remaining stand. Stand damage, including gap formation and damage to individual trees, is discussed in Chapter 4 and soil damage, including compaction in skid trails, is discussed in Chapter 5.

The efficiency of the CELOS Harvesting System (CHS) is investigated in Chapter 6 with emphasis on methods and techniques to restrict damage. The findings of the harvesting research were integrated in the CELOS Management System (CMS) and are discussed in Chapter 7.

### **1.5 Applicability of damage-controlled technology**

The question arises whether logging damage can be restricted when advanced technology as used in developed countries is transferred to tropical countries. In some western countries, control of stand damage is a management objective in harvesting systems (Bol and Leek, 1985; Bol and Beekman, 1989). Management systems have been designed to control soil damage. Some clear felling systems involve intensive movement of vehicles, while others are designed to minimize terrain transport (Heij and Leek, 1981; Staaf and Wiksen, 1984). Thinning operations in managed forests are carried out with special equipment. In selection felling every effort is made to keep the remaining stand in a healthy state, by carrying out each periodic harvest with the greatest of care. Avoiding or restricting stand damage is a major objective of the West Germany 'Waldschonende Holzernte' (Anon., 1985). Damage-controlled logging aims to use the technical and ecological potential of the forest without endanger its existence.

Prospects for damage-controlled logging are far better in developed temperate countries than in developing tropical countries. There are still many socio-economic barriers in tropical countries to the revaluation of the forest as a vital national resource. The tropical rain forest also has characteristics adverse to the implementation of modern technology. These are related to tree dimensions, wood quality, stand density and terrain conditions. This problem is explained in the following review of some well known techniques and methods in temperate forestry.

*Directional felling and tree protection.* In temperate forest, damage to trees during harvesting is confined to mainly the lower trunk, up to 2 m above the ground, which is most susceptible to damage by falling trees and moving machines. Knuttel (1983) found that 75-90% of stem injuries occurs below 2 m in 60 year-old spruce (*Picea spp.*) thinnings. This kind of damage may lead to wound infection and fungi attack, resulting in a decline in wood quality. Dietz (1981) has assessed the economic loss of damaged trees in spruce/pine stands in the State of Baden-Württemberg, West Germany, to be approximately US\$ 3.2 million per year; a loss

that could easily be avoided or restricted by simple measures.

Directional felling is practised in temperate areas to improve efficiency of logging operations and to restrict damage to the remaining trees. In selective felling in coniferous stands, directional felling had led to a substantial reduction in the number of damaged trees (Dietz, 1981; Sanktjohanser, 1985). Special tools, such as wedges and felling levers, are used to control the felling direction. Unfortunately, application of directional felling is difficult in tropical rain forest because of characteristics such as large and voluminous crowns and the abundance of woody climbers and lianas. Yet, this technique can indirectly restrict skidding damage because a more efficient transport pattern of felled trees can be obtained.

Individual tree protection can reduce bark damage. Stem foots can be covered with rubber mats, or marked with a conspicuous colour to attract the attention of machine operators. Bark injuries can be treated immediately after logging with a chemical agent to prevent rot. These measures are all economically justified in well stocked commercial stands in temperate zones. In tropical forest, however, the low density of commercial trees makes such measures uneconomical. Besides, tree crowns are more exposed to damage than trunks. Treatments of wounds, especially from crown injuries, would be uneconomical. Such trees are best felled or left to natural recovery. Recommendations made to top crowns of large standing trees to restrict felling damage (Noelmans, 1979) are far beyond reality from the points of view of economy, safety and work organization. Although it is almost impossible to carry out directional felling in the same way as in temperate regions, a part of the present study concerns possible adaptation of this technique for tropical regions.

*Forwarding, skidding or animal traction.* Damage-control in temperate forest is often related to the harvesting systems applied: full tree, tree length or short-wood logging (Bol, 1968; Staaf and Wiksen, 1984). In the short wood system, for instance, trees are bucked and sorted into utility assortments at the stump area. Although various means of transport can be used, forwarders are best suited for this work. This articulated terrain tractor can be equipped with a hydraulic crane to load the wood onto its trailer (loading space), while the forwarder remains on the strip road.

Forwarders are not suitable for the transport of long lengths of heavy tropical hardwoods. The crane capacity is too limited, and the gross weight of the heavier types of forwarders restricts travel on soils of low bearing capacity. The present type of forwarders does not allow adaptation to rain forest conditions.

Horses are being re-introduced in forestry operations in some West European countries. In many tropical countries buffaloes are used to transport timber in the agricultural off-season (Laarman et al., 1981). Elephants are used in some Asian countries (FAO, 1974). In Suriname, however, animal traction of tropical hardwood is greatly restricted by log dimensions and in dryland forests by lack of water and proper food for buffaloes (see Appendix II). In the remote dryland forest areas buffaloes proved to be difficult to manage (see Section 2.2). While not prohibitive,

animal traction would be difficult to use in commercial logging.

The articulated frame-steered, rubber-wheeled, cable winch equipped skidder is widely used for timber extraction in tropical rain forests. The machine is very mobile, manoeuvrable and stable due to its low centre of gravity. Its flexibility in handling logs of various lengths and relatively high travelling speed make it most suitable for skidding operations, also in combination with crawler tractors. Since its introduction in the tropics in the 1960s, the steering and winch systems have been improved substantially. The machine is comparatively easy to handle and maintain. Also, from the point of view of damage control, the wheeled skidder fits into the management system envisaged. In the present study much attention is paid to terrain transport by wheeled skidders.

*Low-pressure tyres.* Reducing the ground pressure of harvesting machines helps to prevent soil damage and trafficability problems. Twin-tyres with wide treads and low inflation pressure tested in forest operations in West Germany and Switzerland were found to reduce soil disturbance and compaction, while increasing productivity (Nipkov, 1983).

High-flotation tyres, 1.25-1.70 m wide, have performed well on wet and swampy soils (Mellgren and Heidersdorf, 1984). Productivity in wet ground increased up to 60% and fuel savings per unit volume up to 40%. Soil disturbance (rutting) and soil compaction decreased significantly and machine stability improved in hilly terrain.

The drawbacks of low-pressure tyres for application in rain forest logging are the additional capital investment, reduction of machine manoeuvrability and penetration capacity due to the wide tread, and also increased susceptibility to punctures from stumps and terrain obstacles. Under tropical rain forest conditions a tyre width of 58 cm and inflation pressure of 138 kPa are standard for wheeled skidding. Thus in the present study all experiments were carried out with standard tyres.

*Cable yarding and air transport.* In some tropical countries cable yarding systems are used for log extraction. One such system, the High Lead System, is relatively cheap but destructive (FAO, 1974). Compared to the more advanced skyline yarders (McConagil, 1978), more yarding trails are formed in the High Lead System, and consequently more skidding damage is done. Although cable yarding is not used in dryland rain forests in Suriname, yarding techniques may help to control skidding damage. The same may be the case for helicopter logging and balloon logging. Both systems have the advantage that fewer roads have to be constructed for log extraction (Conway, 1982). However, application of these techniques in tropical rain forests is not as yet economic (van Leersum and Zijp, 1985).

## 2 Review of timber harvesting practices and forest management in Suriname

For centuries exploitation of the tropical rain forest has been uncontrolled without due regard to resource management. Timber harvesting was the main purpose. This was also the case in Suriname until the 1950s, in spite of various attempts since 1904 to introduce forest management. These initiatives were made by the government in an endeavour to use the country's resources more intensively and efficiently. Even today, timber harvesting may be considered to be a type of mining operation, only logging methods and techniques have been changed.

Uncontrolled, selective logging was carried out until around the turn of the last century, when the colonial government began to pay attention to the forestry sector in relation to the country's economy. Since then forestry development has largely been determined by government policy and by the availability of funds from the Netherlands.

The first forest inventories and research were carried out when the government established a forest service, "Boswezen" in 1904. The management concept of controlled selective logging was developed in this period (Section 2.2). However, the Boswezen was closed in 1925 because of lack of funds and it was almost 22 years later before the Suriname Forest Service was established (Gonggrijp and Burger, 1948).

Since 1947 numerous studies and projects have been carried out on forest policy and management by the Suriname Forest Service (Dienst's Lands Bosbeheer, LBB). A system of concessions based on management plans was introduced (Section 2.3) and preparations made to introduce scientific forest management, to formulate a forest policy, and to design forest legislation (Section 2.4).

Until about 1977, forest policy favoured the establishment of tree plantations with emphasis on Caribbean pine (*Pinus caribaea*), while the management of natural rain forest was purely experimental. The disappointing results of pine plantation establishment forced the Forest Service to re-evaluate its policy on sustained timber production (Fraser et al., 1977). A silvicultural system, known later as CELOS Silvicultural System (CSS), was developed by the Centre for Agricultural Research in Suriname (CELOS) and the Wageningen Agricultural University, and accepted by the Forest Service as a promising alternative (Section 2.6).

Harvesting and management practices are reviewed to show how ideas about

sustained yield management in Suriname have developed. An overview of the systems applied is given in Table 2.1.

## 2.1 Forest exploitation before 1900

Before 1900 uncontrolled, selective logging practised in Suriname was a creaming operation with limited effect on the ecology of the remaining stand. Forest resources were of minimal economic significance. Timber production was very low and sawn timber had to be imported to meet domestic requirements.

Logging and timber processing centres known as 'houtplantages' or timber estates, were private enterprises based on slave labour (Kappler, 1983; Bruijning et al., 1977) and had been granted in allodial property to private individuals. By 1863 only 16 timber estates remained, each about 3000 ha in area (Plasschaert, 1910).

Manual handling and conversion of logs were limiting factors to increase

TABLE 2.1. Overview of logging practices and forest management concepts in Suriname

| Period      | Management concept             | Logging method                       | Logging equipment                       | Main projects                                     |
|-------------|--------------------------------|--------------------------------------|---|---|
| before 1900 | uncontrolled selective logging | manual felling and transport         | axe, handsaw                            | n.a.  |
| 1904-1947   | selective logging              | manual felling, animal transport     | axe, handsaw<br>buffaloes               | government forest exploitation                    |
| 1947-1965   | management plans               | manual felling, mechanized transport | axe<br>crawlers, trucks                 | tree plantations                                  |
| 1965-1977   | regular management             | manual felling, mechanized transport | power saw<br>skidders, crawlers, trucks | tree plantations, monocyclic natural regeneration |
| 1977-1984   | CELOS management system*       | manual felling, mechanized transport | power saw<br>skidders, crawlers, trucks | polycyclic natural regeneration (CMS)             |

\* In development

production and quality of sawn wood. Only trees of prime timber species were harvested. Felled trees were hewn into square piles by removing the sapwood to reduce weight for transport to the river landings. Logs were skidded manually over a corduroy path constructed of poles and young trees. This was labour intensive taking a day for no less than 22 men to skid a log of 2.25 m<sup>3</sup> a distance of 5 km (Berkhout, 1903). The weight of squared logs could be reduced further by sawing them into boards before transport. However, in general the logs were transported to a river landing and then sawn. This was done using a simple wooden frame so that logs could be scalloped more conveniently off the ground.

For centuries transport difficulties restricted timber harvesting to strips of a few kilometres wide along the rivers and creeks. More remote forest areas remained inaccessible because of the lack of animal or machine traction. This type of strip logging affected the remaining stand, even though only a few trees per hectare were harvested. Sometimes, considerable damage was done in the stump area and along skid trails (Plasschaert, 1910). Creaming of the best commercial trees without replacement measures has led to selective forest depletion. Some of the pole size regeneration of commercial species was removed to construct corduroy skid trails, as species were used indiscriminately for this purpose. Since regeneration is usually concentrated around the mother trees, a relative large proportion of young commercial trees was used for trail construction.

As short-term timber use was the sole objective, conventional selective logging must be considered to be a non-sustainable type of forest management. The assumption that conventional logging has no serious impact on the remaining stand (Estève, 1983) is valid, if the forest is set aside after harvesting long enough for natural recovery. The real threat is postponed to the second harvest, which may be soon after the first if most accessible resources are depleted. Loggers are then forced to use smaller trees or trees of lesser quality. Berkhout (1917) reported depleted and heavily affected stands near the agricultural estates along the main rivers.

## **2.2 Selective logging, 1900-1947**

After abolition of slavery in 1863, the timber estates declined in importance. A group of small concession holders succeeded in supplying the domestic market, often by purchasing timber from contract labourers, mainly Bushnegroes and Amerindians. Contracted fellers were free to select the timber and to carry out all harvesting operations. The concession holder inspected the timber at the river landings and paid the labourers for approved logs. Logging techniques were similar to those on the timber estates and were neither efficient nor well organized. Thus logs and sawn wood continued to be expensive and timber had to be imported to meet domestic demand.

The importance of management of accessible forest was emphasized by Berk-

hout (1903), who opposed the idea that the tropical rain forest can regenerate rapidly without human interference. He considered that the narrow focus on balata export should be gradually widened to other timber products in order to maintain a stable market position. A rational system was proposed to bring Suriname's forests under scientific management (Berkhout, 1903; 1917).

In spite of the lack of forestry research and management experience in Suriname, the system proposed by Berkhout was based on realistic assumptions. Aware of the fact that effects of management interference can only be studied in the long term, he suggested a period of 50 years would be necessary to develop a system. However, the forest service lacked both funds and staff. In this respect, forest legislation, the cornerstone of forest management, was not considered relevant as the instruments for executing a forest law were not available (Berkhout, 1917).

The Lawa railway to serve the gold fields in the interior (Bruijning et al., 1977) was projected over a distance of almost 50 km in rain forest areas. These areas were recommended as reserves for forest production and in 1905 a site along the railway was selected for research (Gonggrijp, 1925). The total area was 10 000 ha with extension to 20 000 ha.

The original experimental set-up was a commercial forest exploitation area of 10 000 ha, divided into compartments of 200 ha for annual coupes of 200 ha in rotation periods of 50 years. Diameter limit was 60 cm dbh and yield assessed at 10 m<sup>3</sup> per ha net volume. A gradual conversion to a two-storey forest was envisaged with an age difference of 50 years between the upper and middle storey. Regeneration of commercial species was to be tended manually, with liberation and refining fellings to stimulate growth of young trees. Additional planting and sowing were recommended to improve stand quality and to fill gaps in the forest cover (Berkhout, 1917).

Harvesting operations were given much attention in Berkhout's system. Animal traction was proposed to overcome the key problem in the terrain transport of logs. Apart from requiring fewer labourers, using buffaloes to skid heavy logs would eliminate the need to hew logs prior to transport and would mean higher conversion rates as logs could be sawn at the mill yards. The railway was an excellent link in the transport chain, connecting the forest with the mills for domestic processing, and with the harbour for export.

There was concern about the stability of the forest ecosystem even though little was known about it at that time. The proposed management system was derived from the 'Plenterwald-System', developed by the forestry schools of Switzerland (Knuchel, 1947; Osmaston, 1968) and was not based on clearfelling systems. Although clearfelling of natural forest and replanting with native commercial species was considered to be the best way to improve forestry in Suriname, the cost of stand establishment was too high for the government to finance. A short-term solution with direct profits was needed. The risk of introducing clearfelling without research was recognized and these techniques were tested on small plots of a few hectares.



A rotation period of 50 years was chosen possibly to save the cost of regeneration tending. As no prescriptions were given for this tending and liberation felling, it is not clear how a more uniform stand was to be achieved. The assumption that this could be done within one rotation of 50 years was not explained.

After four years experimenting, the situation at the end of 1909 was reported to be very discouraging. At that time 1940 m<sup>3</sup> of logs had been felled of which just 500 m<sup>3</sup> were transported to Paramaribo. A further 500 m<sup>3</sup> were skidded to a forest landing and about 900 m<sup>3</sup> were left in the forest. The conversion rate was extremely low, not exceeding 30%, which meant at least 70% was wasted when logs were squared. Without experienced drivers, the buffaloes were difficult to handle and suitable food for the animals was not easy to find. Even though wages were relatively high, it was difficult to get labourers to work on a regular basis.

The forest conversion system was never tested. When the model-forest exploitation along the Lawa railway did not succeed, the first measures were taken to dismantle the Boswezen. This was a most unfortunate development since serious attempts had been made to guide and support forest operations with research. Plasschaert (1910) concluded that mechanized logging should be introduced and that the scale of operations be increased. The very disappointing results, as wasteful and damaging as private operations, were explained as being the consequence of lack of technology. Mechanized logging operations used in the Philippines were recommended as an example for Suriname to follow (Plasschaert, 1910).

Although Plasschaert's approach is quite understandable from the point of view of efficient management, it overlooked simple solutions, such as recruitment and training of skilled buffalo drivers. His observations and measurements were not supported by practical experiments. Furthermore, the comparison with the Philippines where commercial stocking was substantially higher than in Suriname was not relevant. According to Pfeiffer (1929), crawler tractors would have been too expensive for forest operations in Suriname, since a minimum harvestable volume of 60 m<sup>3</sup>/ha was required for economic recovery.

The failure of governmental forest exploitation to generate funds for sustained forest management led to the disbandment of the Forest Service. This drastic decision was based on financial considerations only (van Traa, 1946), in spite of valuable work done in biology and taxonomy (Pulle, 1906), timber technology (Pfeiffer, 1926) and forest inventory (Gonggrijp, 1925).

### **2.3 Selective logging in managed concessions**

When re-established in 1947 the Suriname Forest Service was charged 'to manage the country's forest to yield in perpetuity the maximum benefits for the community by inventory, research and by inspection and supervision of forest operations and

timber exports' (Vink, 1964a). This policy, although restricted in objective, opened the way to some type of control over the extensive forest area. It was the first time that a policy had been formulated and a forest service established to conduct research as well as to execute policy. After 22 years of unsupervised forest exploitation, a new phase in forestry development began in Suriname.

The Forest Service had to start all over again because most forestry experiments from the previous period (1904-1925) had collapsed. Gonggrijp, who worked in Suriname as Conservator of Forest from 1907 to 1923, returned in 1947 to help the colonial government to prepare and implement a forest policy. His findings were published in a comprehensive handbook on post-war forestry in Suriname (Gonggrijp and Burger, 1948). The study, however, overestimates the regeneration capacity of the natural rain forest. Based on the assumption that an average annual increment of 2 m<sup>3</sup> per ha of desirable species is possible without human interference, the annual coupe in the exploitable forest belt was assessed to be two million m<sup>3</sup>. Annual production for export only was optimistically predicted to be in excess of 400 000 m<sup>3</sup> by 1950. This target was never reached.

Gonggrijp's assessment was based on his own experiments of a few well known commercial species of excellent technical properties, which was undertaken between 1907 and 1923. But with the closure of the Forest Service in 1925, most of these forest plantations were occupied by shifting cultivators. Conclusions on timber growth and yield drawn from remnants in 1947 were highly speculative. The study reviewed forestry and made recommendations for the organization of the newly founded Suriname Forest Service, but no new views on forest management were presented. Enrichment planting in logged-over forests and establishment of plantations of valuable trees on cleared forest sites were the main recommendations.

The first legislation to bring forest areas under sustained management consisted of three ordinances enacted in 1947 and 1950 (see Section 2.4). These ordinances have greatly influenced forestry development. A system of managed concessions was introduced for sustained production in inventoried virgin forest. The aim was primarily production, although some provisions were made to protect the forest and to restore production capacity. These were harvesting rather than management plans, since no provisions for yield regulations and control of the growing stock were made. Nevertheless, a basis was established for some kind of management and at least logging operations were regulated.

One of the oldest management plans is that for the 'Atjeh' concession (Snijders, 1953). As well as describing the geography, terrain, forest characteristics and commercial timber stocking, a harvesting plan, based on a compartment felling system was presented. The average size of a compartment was 200 - 300 ha and the borders were formed by natural water courses, inventory lines and truck roads. Revisions of management plans also emphasized the compartment design and road planning, felling stipulations, royalty regulations and administrative obligations (LBB, 1961). These plans dealt with neither regeneration nor post-harvesting

treatments. The only obligation on the concessionaire was to release harvested compartments to the Forest Service for treatment, if requested.

## 2.4 Regular management

The absence of a consistent forest policy supported by forest legislation has been the main factor limiting forestry development in Suriname (Vink, 1964a; 1970; Bhadran, 1965; Fraser, 1973; Schmidhüsen 1974). The Timber Ordinance of 1947 is still the only legislation to establish governmental control of the national forest estate. This ordinance was derived from the Balata Ordinance of 1914. At that time, balata was the second major export product and the government tried to safeguard the resource, by protecting the bolletrie or bullet tree (*Manilkara bidentata*). Stipulations were made for tree tapping, harvesting cycle and gum preparation. Most balata concessions were located in the State Forests and annual renewal was required for effective use of a concession area. The system of gum collection could at best be considered as a form of forest product exploitation with provisions for sustained yield.

A draft regulation prepared by Pfeiffer (1929) was the basis for the ordinances of 1947 and 1950: the Timber Ordinance (1947), the Special Concession Ordinance (1947) and the Timber Export Ordinance (1950). Concessions, felling permits and licenses are issued on different terms for timber harvesting and collection of minor forest products. The maximum duration of a concession is ten years, but annual renewal is required, and the maximum size is 50 000 ha. Permits to harvest timber for an indefinite period are granted to Amerindians and Bushnegroes only. Other features of these ordinances include (Vink, 1970):

- stipulations for royalties on forest products, concession fees, export duties and penalties;
- harvesting regulations including the protection of selected tree species;
- regulations for the establishment of forest reserves and natural reserves;
- a special agreement (Special Concession Ordinance of 1947) by which the Bruynzeel Suriname Wood Company (BSH) received a concession area of 500 000 ha for 25 years without the obligation of annual renewal;
- quality control by the Forest Service of timber for export.

In 1947, the Forest Service was given responsibility for execution of the Ordinances which are still the only forest legislation, in spite of efforts in the 1960s to improve the legal status of the sector (Bhadran, 1965). A major shortcoming is the narrow definition of forest policy focusing on maximizing forest production. In 1964, an official government statement on development policy emphasized other objectives, such as reforestation and nature conservation, but this was not sufficient (Vink, 1970). Important objectives such as forest ownership, legal control of forest estate (forest legislation) and permanent allocation of forest reserves were not mentioned

in the statement. Moreover, the legal status of the Forestry Belt was not defined in spite of recommendations made by the Forest Service.

The term 'regular management' was used by Bhadran (1965) in his proposal to introduce scientific forest management in Suriname. As a follow-up to Bhadran's consultancy, a forestry development project was executed by FAO and the Suriname Forest Service in the early 1970s with emphasis on management (Fraser, 1973), economics (Wardle, 1974), legislation (Schmidthüsen, 1974), utilization and industrial development (Bowels, 1974). A forest law covering all aspects of forest management was proposed and studies were carried out on stand establishment of utility and industrial timber species, such as Caribbean pine. Subsequently 30 or more studies, consultancies and surveys carried out by FAO and other international agencies gave the impression that preliminary forestry research was no longer required (Mckenzie, 1981).

It is not the intention to summarize the results of these studies, but the main statements on forest management and related forest policy are noted below:

- forest management should serve the purpose as formulated in the forest policy (Bhadran, 1965);
- forest policy should be supported by a Forest Law (Fraser, 1973; Schmidthüsen, 1974);
- the Forestry Belt should be established as a permanent legal forest estate, divided into management zones (Fraser, 1981);
- some of the Forestry Belt should be converted into plantations of Caribbean pine, but the majority should be managed on the basis of natural regeneration for which the monocyclic system of Dawkins (1958) was adapted by LBB (see Vink, 1964b);
- more intensive use of the natural forest is a prerequisite to increase production and to reduce the cost of harvesting and regeneration (Bowels, 1974).

In most studies carried out in 1965-1982, timber felling as the first management intervention was ignored completely. No provision was made for harvesting practices, for neither damage restriction nor logging efficiency. Only one descriptive study was devoted to forest concession practices and roundwood production (CESWO, 1981), but was confined to data collection only.

## **2.5 Present timber harvesting practices**

A total area of 2.2 million ha of forest is allocated to production including 1.3 million ha in the Forestry Belt (Fig. 2.1). About 1.8 million ha has been granted to concession holders and approximately 0.5 million ha to Amerindian and Bush-negro communities (Table 2.2). Most concessions are relatively small and only three companies have more than 30 000 ha. A minor part of these concessions is

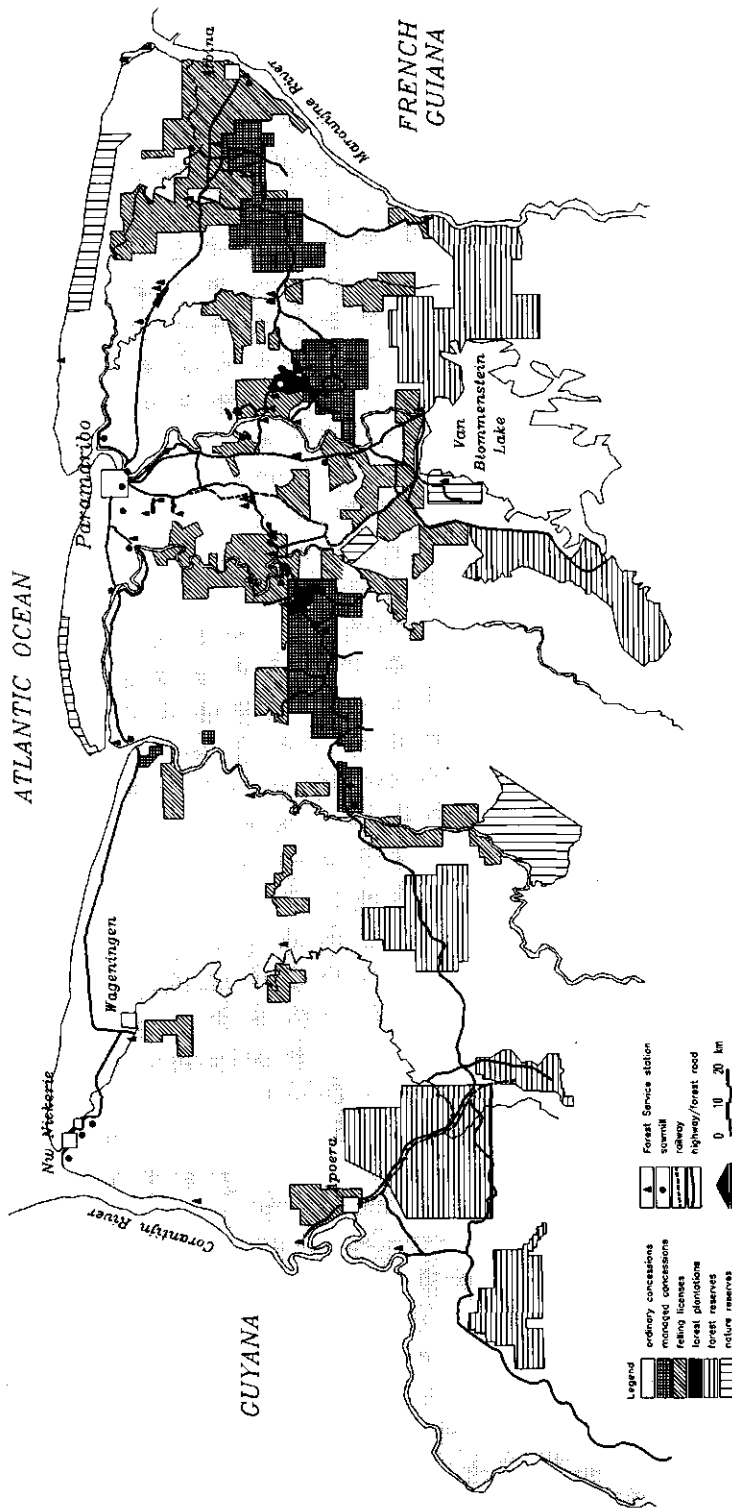


Fig. 2.1 Forest land use map of northern Suriname

harvested with a management plan of the Forest Service (Section 2.3).

The Forestry Belt has been made accessible by 2000 km of allweather forest roads. Timber harvesting activities are concentrated in several regions, separated as management zones by natural boundaries and forest roads and coinciding with basins of trafficable rivers (Fig. 2.1):

- Patamacca zone, mostly exploited by the Bruynzeel Wood Company (BSH). Only the southern part of the BSH concession is covered with sufficient virgin forest to provide the company with timber for a few more years. South of the zone is the Nassau forest reserve. The zone has good access to labour in the mining town of Moengo and the Bushnegro villages along the Marowijne River. It is connected to the processing industry and port facilities in Paramaribo by the East-West Highway and the Patamacca and Cottica Rivers. The collecting point for river transport of logs is the Coermotibo, a tributary of the Cottica River.

TABLE 2.2. Forest areas and types of land tenure in the northern rain forest of Suriname

| Tenure               | Forest area      |              | Portion of forest area situated in Forestry Belt |             |
|----------------------|------------------|--------------|--|-------------|
|                      | (ha)             | (%)          | (ha)   | (%)         |
| <b>Concessions</b>   |                  |              |  |             |
| unmanaged            | 1 065 602        | 38.4         | 455 295  | 42.7        |
| managed              | 76 333           | 2.8          | 74 453   | 97.5        |
| partly managed       | 72 250           | 2.6          | 36 280   | 50.2        |
| Subtotal             | 1 214 185        | 43.8         | 566 028  | 46.6        |
| Felling licenses     | 468 012          | 16.9         | 152 633  | 32.6        |
| <b>State land</b>    |                  |              |  |             |
| unmanaged            | 697 700          | 25.2         | 523 269  | 75.0        |
| forest reserves      | 246 761          | 8.9          | 35 275   | 14.3        |
| nature reserves      | 13 718           | 0.5          | 0  | 0.0         |
| experimental forests | 22 075           | 0.8          | 11 896   | 53.9        |
| Subtotal             | 980 254          | 35.4         | 570 440  | 58.2        |
| <b>Other types</b>   |                  |              |  |             |
| long lease           | 33 207           | 1.2          | 13 800   | 41.6        |
| forest research      | 61 200           | 2.2          | 0  | 0.0         |
| Suralco forests*     | 12 405           | 0.5          | 0  | 0.0         |
| Subtotal             | 106 812          | 3.9          | 13 800   | 12.9        |
| <b>Total</b>         | <b>2 769 263</b> | <b>100.0</b> | <b>1 302 901</b>                                 | <b>47.0</b> |

Source: LBB Statistics; CESWO (1981).

\* Owned by the Suriname Aluminium Company

- Mapane zone, relatively close to Paramaribo and easily accessible by road or river (see Section 3.2). Most of the area has been lightly exploited and a few concessionaires are still in operation. About 4000 ha of pine plantations and many silvicultural experiments are located in this zone. Log collecting points are Auca and Joden Savanne on the Suriname River and Java on the Commewijne River.
- Central Suriname zone (basin of the Suriname river) has been harvested once in most concessions and currently some areas are being harvested for a second time. Construction of a road to the Pokigron forest reserve has improved access but the north and east are poorly accessible. Most production forest has been granted to local communities. Part of the area is under pressure from shifting cultivators because of decreasing forestry production and a lack of alternative employment. Afobaka and Berg en Dal at the Suriname River are the main log collecting centres. Directly south of this zone is Brownsberg, a large nature park.
- Moeroekreek-Coesewijne zone is the main timber production area, although a substantial part has already been harvested. Only the BSH concession, Kabo, is largely unexploited. Some 3000 ha of pine plantations have been established in the catchment of the Coesewijne river. The main log collecting point is Moeroekreek at the Saramacca River, which is also connected by road to Paramaribo.
- Wayombo-Nickerie zone consisting mainly of unexploited concession of BSH. Timber is harvested mainly by a few Bushnegro communities in the east. Logs are transported to Paramaribo via Bitagron at the Coppename River. South of the zone are three forest reserves which were inventoried in 1971-1979.

There is a network of 20 or more forest guard stations along forest roads and large rivers from which log flow can be followed, harvesting operations inspected, and production registered for taxation. An efficient administrative system has been set up but lack of funds and skilled manpower make it difficult to maintain up-to-date records. Timber royalties, which increased in 1981 to approximately 10% of the value at mill yard, are still low compared to the costs of road building and maintenance, timber inspection and overall supervision. The road building programme has, in fact, been heavily subsidized by the government.

Overall log production from dryland rain forests has not exceeded 300 000 m<sup>3</sup>/y in the past decade. More than 50% of this quantity is processed by BSH and the remainder by 34 small sawmills. The BSH is the only venture producing plywood and particle board, and operating a modern band mill. The smaller ventures, mostly on the large rivers and equipped with gang mills, concentrate on local sales and only a few are able to meet export requirements.

Even before the Second World War, crawler and agricultural tractors were used in some forest operations. Fully mechanized log extraction and transport was first carried out by BSH on the concession Atjeh (Snijders, 1953). The first articulated wheeled skidders were introduced in Suriname in 1965 and within ten years had

become standard equipment. In the same period, the axe was almost completely replaced by the power saw.

Since 1975 no new technical developments have been introduced in the logging industry. Tree felling has generally been improved by training power-saw operators in the 'Jan Starke' Forest Service Training Centre, but terrain transport has remained a problem, in spite of the availability of powerful skidders. Road transport is no longer critical in the log flow. About 30 rebuilt trucks and trailers are used by concessionaires and contractors, while BSH introduced modern transport trucks in 1973.

Three major harvesting systems are in use for freshwater swamp, marsh and mesophytic tropical rain forest respectively. Timber harvesting is generally adapted to the forest type. Wet conditions prevail in all three forest types but in freshwater swamp and marsh forests, water is present almost permanently, thus limiting the use of mobile machines. The system of timber harvesting in Suriname's tropical rain forests is the subject of the present study. The northern freshwater swamp forests were also harvested for timber but their significance has now decreased because of fires and over-exploitation (see Appendix II).

## 2.6 CELOS Silvicultural System

The Suriname Forest Service originally based its management policy on establishment of forest plantations to meet domestic timber demand, and improvement of exploited stands by natural regeneration.

After natural regeneration of the exploited forest without human interference had been shown to be a slow process (Schulz, 1967), more emphasis was placed on silvicultural systems such as enrichment planting, strip planting and uniform plantation establishment of fast growing species. The Forest Service expected that accessible timber stocks would be exhausted within a few decades and proposed to extend plantations of Caribbean pine (*Pinus caribaea* var. *hondurensis*) established originally for a pulp project. In 2 five-year planning periods the pine plantations were extended to more than 8000 ha by the end of 1977. The prohibitive cost of stand establishment (Fraser et al., 1977), coupled with disappointing growth of pine timber and the high cost of weed control, triggered the decision to halt further extension and to re-examine the uses for present stands.

Controlled natural regeneration of the exploited rain forest was initially based on the monocyclic system developed for Uganda (Dawkins, 1958; Schulz, 1960; Vink, 1964b; Boerboom, 1965). This silvicultural system may be characterized as 'conversion to uniform' (Bhadran, 1965) by treatment of selectively logged forest. The treatment implies removal of all non-commercial trees above a certain diameter, say 10 cm dbh, by chemical thinning methods. The remaining commercial stand is then tended in different stages of development. Thinnings and liberation



treatments are necessary to improve quality and growth of future trees and a period of 60 – 80 years is required for the next harvest.

Early experiments with the monocyclic system were promising but the intensive tending due to immense weed problems and rapid recruitment of light demanding pioneer species made further development unattractive (Boerboom, 1965; Fraser et al., 1977). Another form of sustained management of the rain forest that was ecological sound and economically feasible was required. In 1975 a silvicultural system, later known as the CELOS Silvicultural System (CSS), was formulated. This polycyclic system was the result of 15 years silvicultural research in Suriname by CELOS and the Wageningen Agricultural University. It was initiated by Schulz, Boerboom and de Graaf (de Graaf and Geerts, 1976; de Graaf, 1982; 1983) and developed further in the project 'Human Interference in the Tropical Rain Forest Ecosystem' (Jonkers and Schmidt, 1984; de Graaf 1986; Jonkers, 1987). The research was undertaken in Kabo and Mapane areas (Fig. 1.1). For comprehensive description of CSS, reference is made to de Graaf (1986), Jonkers (1987) and Boxman et al. (1985; 1987). Only the mainlines of the system are discussed here.

The starting point of the CSS is the forest remaining shortly after commercial logging. Following an inventory of commercial trees, a schedule is determined to reduce competition of other trees by manual ring-barking or by treating them with a solution of the chemical agent 2,4,5-T. Three refinements are scheduled to reduce the basal area from 28 to 12 m<sup>2</sup>/ha, from 20 to 10 m<sup>2</sup>/ha and from 18 to 15 m<sup>2</sup> ha, in the first, the eight and the 15th year respectively after logging. These thinnings aim to promote growth of commercial species. De Graaf (1986) has assessed that a rotation period of 20-25 years is sufficient to allow a second harvest of approximately 20 m<sup>3</sup>/ha. The third treatment is recommended but depends on the development of the basal area of commercial species. Before each treatment, an inventory is required to determine whether intervention is necessary, and to estimate the diameter limits of the competitive trees to be removed. Detailed instructions are listed for the application of CSS (de Graaf, 1986).

Within the scope of the project, field experiments with CSS were continued by Jonkers (1987) to improve the system and to examine the ecological basis. His 'MAIN Experiment' was designed to test the system on a practical scale and to adjust the refinement techniques. The treatments were adapted to the forest structure and in principle restricted to only two refinements without pretreatment inventory. The CSS proved to be an acceptable silvicultural system in terms of both economic and ecological considerations, provided that careful logging is performed. Although the system is still in development, careful application on field scale could be recommended for specific types of tropical rain forest. Jonkers' MAIN Experiment included a refinement of 200 ha rain forest. De Vletter (1980) proposed to apply the CCS technique in a LBB research forest of 640 ha (see Chapter 3).

The CSS should be regarded as a component of a forest management system since it is designed for sustained yield. This management system has to cover all

forest operations including harvesting and silviculture. As one of the objectives is a felling cycle of 20 to 25 years, harvesting operations will be performed more frequently than in uniform monocyclic systems with three-fold rotation periods. The CSS is a selection system which requires periodic harvesting of volumes equal to the increment of the commercial stock (see Knuchel, 1947). A major constraint to maintaining the ecological structure of the remaining forest was the absence of a sound and controllable timber harvesting technology.

## **2.7 Objectives of the CELOS harvesting research**

When a polycyclic system such as CSS was developed, it became clear that an acceptable quality of the remaining stand is a prerequisite for a successful application. Sufficient sound young trees, saplings and seedlings should be left in the harvested forest to guarantee fast recovery and regrowth of the commercial stand. In this respect, logging operations should be controlled to restrict stand damage.

The first measure should be to limit the harvesting intensity by optimizing the choice and minimizing the number of trees to be felled per hectare. A diameter limit for harvestable trees is often used for this purpose. In Suriname the minimum dbh is now 35 cm for all commercial timber species. However, this measure is not sufficient to control the growing stock of commercial trees. A more detailed knowledge of growth characteristics of individual tree species is needed to give more accurate harvesting stipulations. In his MAIN silvicultural experiment, Jonkers (1987) examined the relationship between felling intensity and vegetation damage, and came up with a more flexible scheme with regard to the maximum allowable cut. The second step is the development of logging methods and techniques to restrict damage.

The high cost of a controlled logging experiment on a field scale, made it necessary to give priority to investigation of damage-controlled methods in small-scale tests. The impact of logging intensity was, therefore, not tested in the present study. Jonkers' results were used to estimate the effects of felling intensity in the logging experiments carried out at a fixed intensity of 8 to 10 trees per hectare (approximately 18-20 m<sup>3</sup>/ha). The present study focused on three major objectives:

- assessment of stand and soil damage caused by conventional and controlled logging methods;
- improvement of logging techniques in order to restrict stand and soil damage;
- development of a harvesting system based on restriction of logging damage and improved operational efficiency.

The harvesting system to be developed had to complement the CELOS Silvicultural System directed to a forest management system leaving sufficient small and medium sized commercial trees to secure attractive harvests every 20 to 25 years.

### 3 Research methods and site description

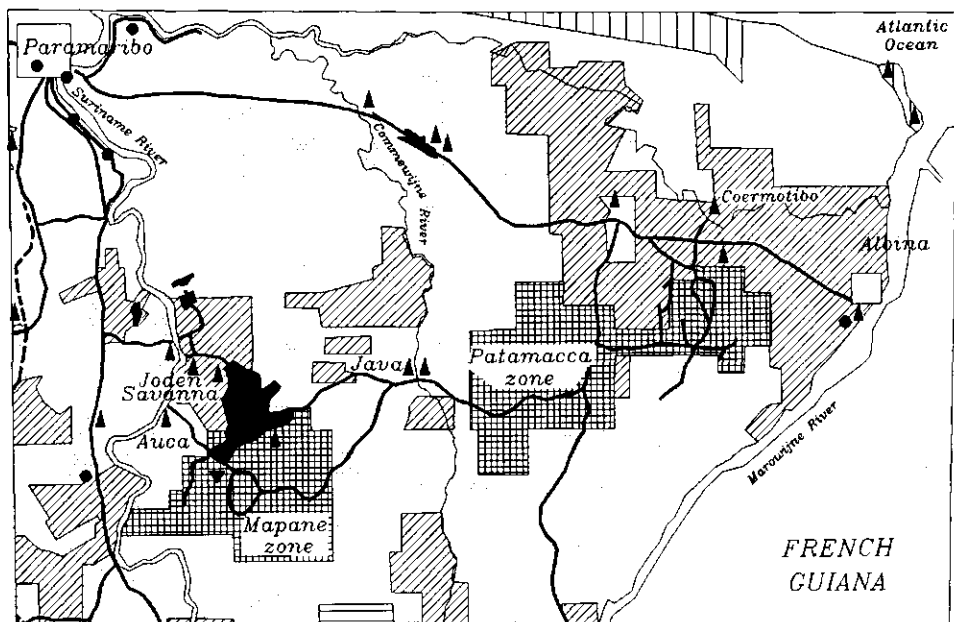
The main objectives of the harvesting study were to assess logging damage in the rain forests of Suriname and to develop a damage-controlled logging system. Three types of experiments were undertaken, two on damage control and one on logging efficiency, in the Mapane and Patamacca regions (see Section 3.2 and Fig. 3.1). The research methods are discussed in this chapter based on the model of stand and soil damage from logging impacts in Table 1.1.

The first group of experiments was designed to assess stand damage done by conventional (uncontrolled) and managed (controlled) logging operations. The original name and code of these experiments was: 'The impact of timber harvesting on the tropical rain forest, particularly in relation to natural regeneration' (Experiment 81/29). Field-work began in 1981 and continued until 1984. Stand damage studies are discussed in Section 3.3.

The second group of experiments focused on the impact of skidding on soil. Performed in 1984 these experiments were called "Skidding operations and soil compaction" (Experiment 84/2). Soil damage studies are discussed in Section 3.4.

The third group of experiments on the efficiency of felling and skidding operations examines the economics of controlled and conventional logging. The data were collected through an administration system designed for all logging experiments. In addition, a winching technique in wheeled skidding (Experiment 82/18) was examined. The harvesting system of the Bruynzeel Suriname Wood Company (BSH) was examined as an example of commercial logging. Coded Experiment 83/12, this study was executed in the BSH forest concession, Patamacca, in the eastern part of Suriname (Fig. 3.1). The potential contribution of this logging system to the development of the Celos Harvesting System was also investigated. Logging efficiency studies are discussed in Section 3.5.

In the LH/UvS-01 Project the first study on logging damage was carried out in the Kabo research area (Fig. 1.1) in the late 1970s. The effects of a combination of three logging intensities and three silvicultural treatments were examined in a large-scale silvicultural experiment. A significant linear relationship was found between logging intensity and damage to the remaining stand (Jonkers, 1987). Jonkers' study dealt with the damaging impacts of logging on the vegetation structure, whereas the present study focuses on damage control and damage prevention by manipulating and improving the logging system. Both studies are



Legend














|  |                      |   |                        |
|--|----------------------|---|------------------------|
|  | ordinary concessions |  | Forest Service station |
|  | Akinto Soela         |  | sawmill                |
|  | managed concessions  |  | railway                |
|  | felling licenses     |  | highway/forest road    |
|  | forest plantations   |  |                        |
|  | forest reserves      |  | 0 10 20 km             |
|  | nature reserves      |   |                        |

Fig. 3.1 Mapane and Patamacca management zones

complementary with regard to the types of damage investigated.

### 3.1 Logging methods

*Conventional or uncontrolled logging* is unplanned, haphazard timber harvesting which is common practice in tropical rain forests also in Suriname (see Section 1.2). Logging operations are not based on a forest inventory and the harvesting area is not laid out before felling. In addition, logging operations are not planned or organized and performed very often by unskilled crews. As a result there is high wastage of harvested timber and considerable logging damage. No attention is given to the remaining forest stand, and harvesting costs are high.

Experiments on conventional logging had two basis objectives; firstly, for

TABLE 3.1. Chain saws used for tree felling in the research areas

| Type       | Capacity<br>(kW) | Weight<br>(kg) | Bar length<br>(cm) |
|------------|------------------|----------------|--------------------|
| Dolmar 152 | 5.0              | 11             | 62                 |
| Dolmar 123 | 3.6              | 9              | 43                 |
| Stihl 070  | 5.1              | 13             | 62                 |

analysis of the efficiency and damaging features of the system, and secondly, for comparison with controlled logging. This system of conventional logging was studied for over 3000 trees felled and transported to three forest landings. Felling was done with heavy power saws and skidding with wheeled skidders (see Tables 3.1 and 3.2).

*Controlled logging* in which forest operations are planned to restrict damage is neither a completely new method nor a modification of the conventional system. The method is based on forest prospecting prior to harvesting, and using these data to design a layout of felling compartments and inventory units, and to plan the logging operations. A tree location map then serves as a guide for the felling and skidding crew and all production activities are recorded on standard forms. The same equipment is used as in conventional logging operations, but the focus is on

TABLE 3.2. Skidders used for terrain transport of logs in the research areas

| Type/model  | Flywheel<br>power<br>(kW) | Winch line<br>pull<br>(kg) | Weight<br>(kg) | Tyre size;<br>track shoe width<br>(inch) |
|---|---------------------------|----------------------------|----------------|--|
| <b>Wheeled skidders</b>                                 |                           |                            |                |  |
| Caterpillar 518<br>(with gearmatic<br>winch model 119)  | 89                        | 14 520                     | 9 662          | 18.4 × 34 (10PR*)                        |
| Timberjack 450 T<br>(with gearmatic<br>winch model 119) | 107                       | 13 590                     | 9 342          | 24.5 × 32 (16PR)                         |
| Clark 666 C   | 83                        | 11 940                     | 8 365          | 24.5 × 32 (16PR)                         |
| <b>Crawlers</b>   |                           |                            |                |  |
| Caterpillar D-6-D<br>(with hyster<br>winch model 56)    | 104                       | 21 380                     | 14 900         | 18.0                                     |

\* PR = Ply rating index

damage control and efficiency of operations to meet the dual objectives of logging efficiency and silvicultural sustainability.

The prospecting method is described in Section 3.3 and logging methods of the controlled logging system as applied in the experiments are described below.

### *3.1.1 Controlled felling*

Controlled felling aims to fell trees in a position favourable for skidding. The work needs to be done by a trained crew of three men. The foreman is responsible for felling and recording. The main aspects of controlled felling are as follows:

- Felling is executed in a predefined sequence, starting for instance, in a logging compartment in the northern section of an inventory unit.
- Felling preparations focus on safety, efficiency and ergonomics following international standards (FAO, 1980; Conway, 1978) and comprises removal of underbrush and lianas, cutting of flight paths and determining the felling direction.
- The felling direction must be chosen with care, with first priority for safety. The shape and size of the tree crowns determine the felling direction in tropical rain forests. The occurrence of lianas linking crowns of neighbouring trees is also an important factor. The foreman needs to use his judgement to assess the natural lean of the tree and the most favourable felling direction.
- Felling is done by making the notch and the back cut with a powersaw. A hinge approximately 3 cm thick is left in the tree to direct the fall (also see Fig. 3.2).
- The felled tree is topped, limbed and bucked, numbered, measured and recorded. Each section of the trunk is numbered on the bottom with a metal disk which remained visible throughout the harvesting process.

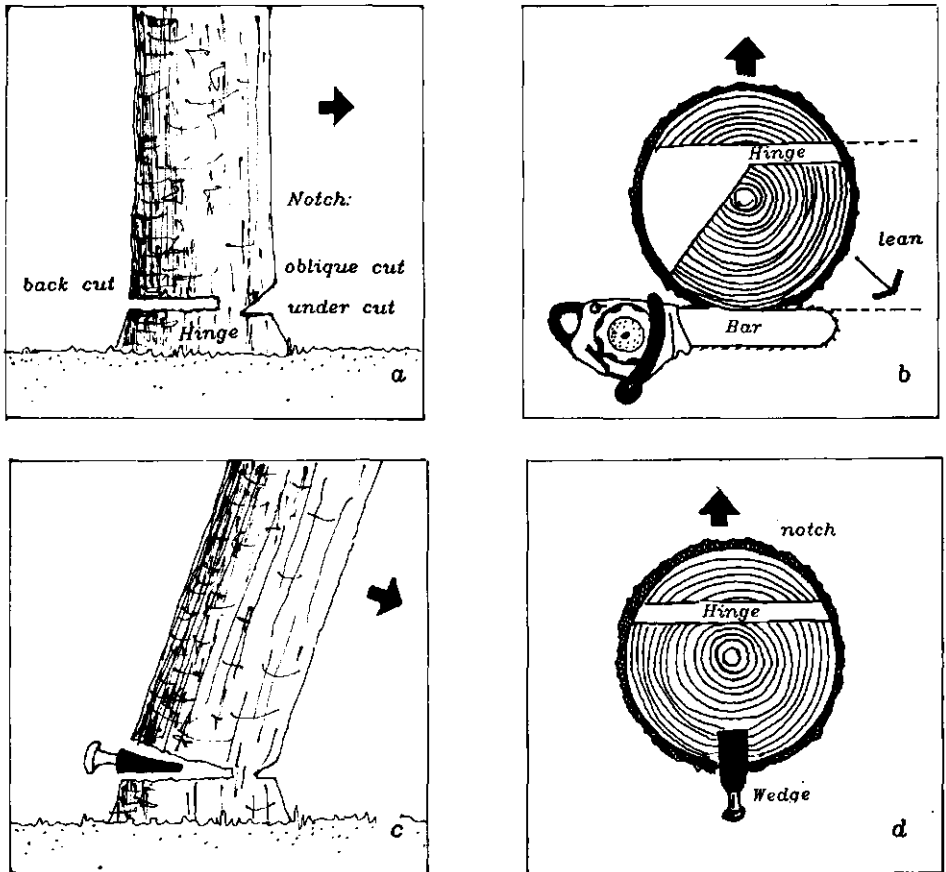
### *3.1.2 Directional felling*

Directional felling means predetermining the lay of the felled tree on the ground (Conway, 1982). The felling direction should be at an angle of 30° to 60° to the adjacent trail (herring bone felling). This form of controlled felling serves both the objectives of efficiency and damage reduction, because logs are positioned for transport, and damage to remaining trees is restricted. The method is standard in many temperate countries and is well adapted to modern forest management. A high level of training is required to execute directional felling safely and effectively.

This method of felling can best be explained by describing basic functions of the felling notch (Fig. 3.2 a). The notch, composed of a (horizontal) undercut and an oblique cut, is sawn to direct the fall of a tree and to prevent splitting of the bud. A tree with a straight trunk and symmetrical crown can be fully directed by the

notch. A second cut (back cut) opposite the notch is needed to induce the fall. A medium sized tree (35-50 cm dbh) with a regular crown, but with a trunk against the required lay can be directed in the desired position by inserting a lever or wedge in the back cut and lifting the bud.

Larger trees have to be handled in another way because of the limited lifting capacity of a manually operated lever. A large tree with heavy crown often cannot be directed against its lean, and has to be directed to fall at an angle one or other side of the lean thus influencing the lay to a certain extent. A tapered hinge needs to be maintained as holding wood to pull the tree in the desired lay (Fig. 3.2 b). The holding wood is in opposite direction to the lean and its shape is determined by the angle between the lean and the lay.



Legend

➔ felling direction

Fig. 3.2 Directional felling: making a felling cut (a and b) and inserting a wedge (c and d)

Directing a tree is facilitated by wedges, one, two or three, depending on the tree diameter and the lean of the trunk, are placed into the back cut (Fig. 3.2 c and d). While the back cut is being sawn by the operator, his assistant gradually hammers a wedge to keep it open, so preventing pinching of the saw bar. When the back cut has been made, the saw bar is removed and hammering of the wedges is continued until the tree is forced over (Fig. 3.2 d).

Directional felling in temperate forests, especially in coniferous stands, aims at achieving a regular pattern of laying trees. In tropical rain forest, the 'natural' lay is not only determined by the trunk lean, crown shape and wind direction, but also by the influence of high adjacent trees with crowns joined with lianas. When the natural lay deviates from the desired lay for transport wedges or felling levers should be used to direct the tree, but even then directional felling may not always be possible.

In the present study a trained crew felled 362 trees by this method. A small powersaw (Dolmar 123) was used instead of the heavy duty types applied in conventional logging (see Table 3.1).

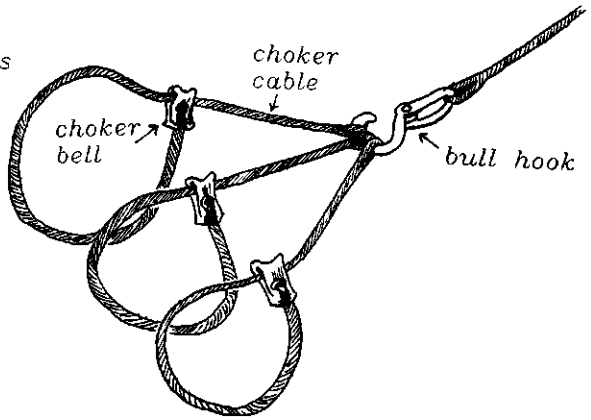
### *3.1.3 Controlled skidding*

A trail network for terrain transport needs to be set up prior to felling and collection of logs. Primary trails are opened by clearing a width of approximately 3.5 m through the forest vegetation with axes and power saws, and branch or secondary trails are marked (cutlassed) so that the transport pattern is visible throughout the entire harvesting operations and the skidder driver knows exactly where to drive. Strict supervision is needed to prevent extra (unplanned) trails being made. Skidding is performed as a set of operations as follows:

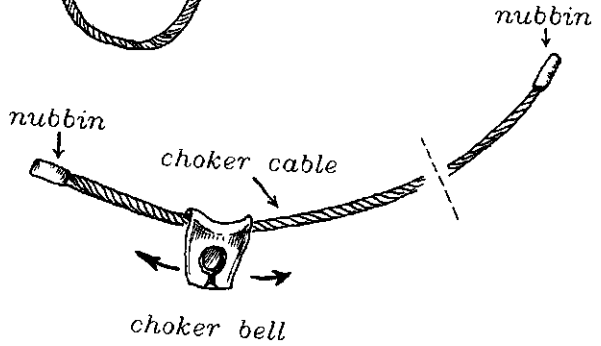
- A systematic search is made for felled trees by a chokerman, using the tree location map. When a log is found, a choker cable (Fig 3.3 b and c) is connected to its end (Fig. 3.3 c).
- The skidder is directed to the logs in the stump area by the chokerman over the shortest, least damaging route.
- One or two logs are then connected to the winch rope by the chokers and skidded along the same route to the trail (Fig. 3.3 d).
- When a full load is collected, the skidder drives to the landing to dump the logs and then returns to the stump area. If more logs are needed to make a full load, the skidded log is disconnected and left along the trail while the skidder returns to the forest for another haul.
- A new load is prepared by the chokerman while the skidder travels to the landing.



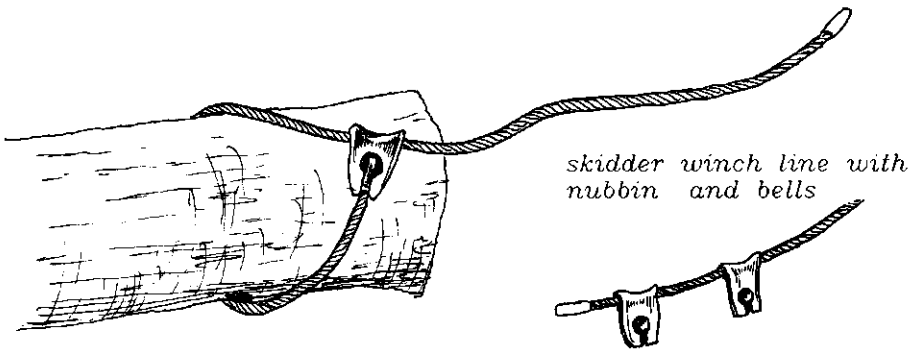
a. spliced eye chokers



b. double nubbin chokers



c. setting the choker



d. winching two logs

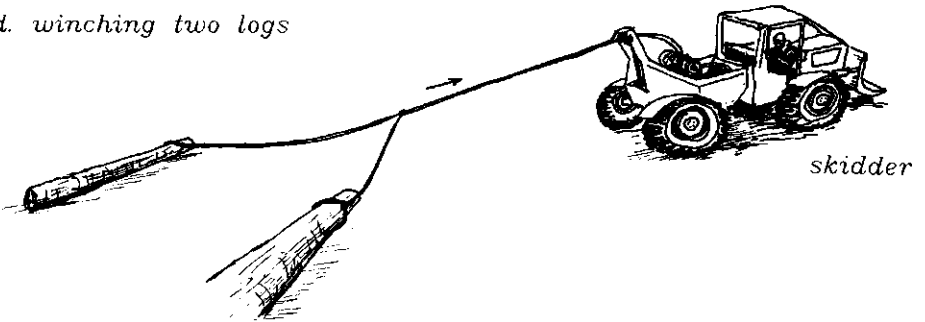


Fig. 3.3 Choker cables

### *3.1.4 Controlled winching*

Winching is pulling logs over some distance while the skidder remains stationary. This method may be used to move logs from stump areas where skidding is impeded by muddy or steep terrain or to prevent driving the skidder through vulnerable stands.

Integrated part of a skidder, the winch is located at the rear and has two main components (see Fig. 3.4):

- the drum, which is powered by the engine (through a power take-off) and hydraulically controlled, is used to pull in and wind up the winch line;
- the winch line, rope or cable may vary in thickness and length, but the most commonly used is 19 mm in diameter and 30 m in length. The line can be unwinded by hand when the engine is out of gear. A hook is attached to the end of the winchline. Conducted by an arch with fairlead and rollers, the line enables the skidder to lift logs off the ground to reduce skidding resistance.

In temperate forests, winching is applied in plantation thinnings to prevent stand damage. The winchline is used to pull trees a maximum distance of 50 m from the stump area to the strip roads, instead of skidding them by a moving tractor. As winching can help to restrict damage substantially, it was decided to investigate the potential of this technique in tropical timber harvesting.

In two experiments, the winching technique was examined for pulling logs from stump to trail. The experiments were executed in the same way as the controlled skidding experiments, except that preskidding was replaced by prewinching. The relationship between log size and winching capacity was examined. The experiments were executed by staff using two hired wheeled skidders, while contractors were employed for the other experiments. The winching experiments are also described by van Leersum (1984a) and Oesterholt (1986).

### *3.1.5 BSH logging*

The BSH logging method is based on prospecting six months prior to felling and on compartment harvesting. The prospecting method comprises a full enumeration of commercial species in inventory units of 250 x 500 m. An experienced crew of five men is able to prospect two units of 12.5 ha each in one working day.

Felling is done with power saws and terrain transport with wheeled skidders and crawler tractors (see Tables 3.1 and 3.2). An efficient recording system is used to meet the requirements of the wood processing plants. A total of 150 trees per crew has to be felled in a week (five working days) and a premium is awarded if this target is exceeded.

Terrain transport is fully mechanized. The combination of wheeled skidders and



Fig. 3.4 The articulated frame-steered wheeled skidder with extended winchline

crawlers has led to a system dominated by machine power (van Leersum, 1984b). All preskidding work is done by crawlers in a simultaneous operation of trail making and log positioning, known as presorting of logs (Noelmans, 1979). Logs are then transported by wheeled skidders to the landings and subsequently by truck to the river terminal at Coermotibo a distance of some 50 km and barge transport to the processing centre in Paramaribo, some 150 km (see Figs 2.1 and 3.1).

The BSH logging system is a type of semi-controlled logging because no measures are taken to prevent or restrict logging damage.

### **3.2 Mapane research area**

The Mapane region (Fig. 3.1) is only 100 km from the capital city of Paramaribo and is accessible by road. Forestry activities started there in the 1950s with forest inventory, road building, and logging operations. Later pine plantations were established in some areas. The forest inventory programmes as well as ecology and management studies gave a good indication of the site characteristics and the forest potential (Schulz, 1960; Vink 1970; Bhadran, 1965; ILACO, 1977). As forest composition and timber harvesting operations are representative of the Forestry Belt (Fraser, 1981), it was decided to execute most timber harvesting studies in this part of the country. The findings are also expected to be applicable to large parts

of tropical rain forests in the Amazon basin, given the similarities in forest ecosystems and types of harvesting systems (Schulz, 1960; Rollet, 1974; Lanly, 1982; Estève, 1983). This assumption is discussed in Chapter 7.

According to a survey done by the Forest Service (LBB, 1960), terrain, vegetation, commercial timber stock and harvesting intensity of the Patamacca region, where one study was conducted, are very similar to the Mapane research area, hence the site characteristics are not described separately.

### 3.2.1 Infrastructure

The Mapane region is one of five management zones in the Forestry Belt, with potential for sustained yield timber production (Fraser, 1981). It is an area of approximately 69 000 ha of lightly harvested forest including 4000 ha pine plantations (Table 3.3). The main forest types are mesophytic tropical rain forest, marsh forest and savannah forest (Lindeman and Moolenaar, 1959). These types are described in Appendix I and in more detail in Section 4.1. The present study was carried out in the mesophytic tropical rain forest.

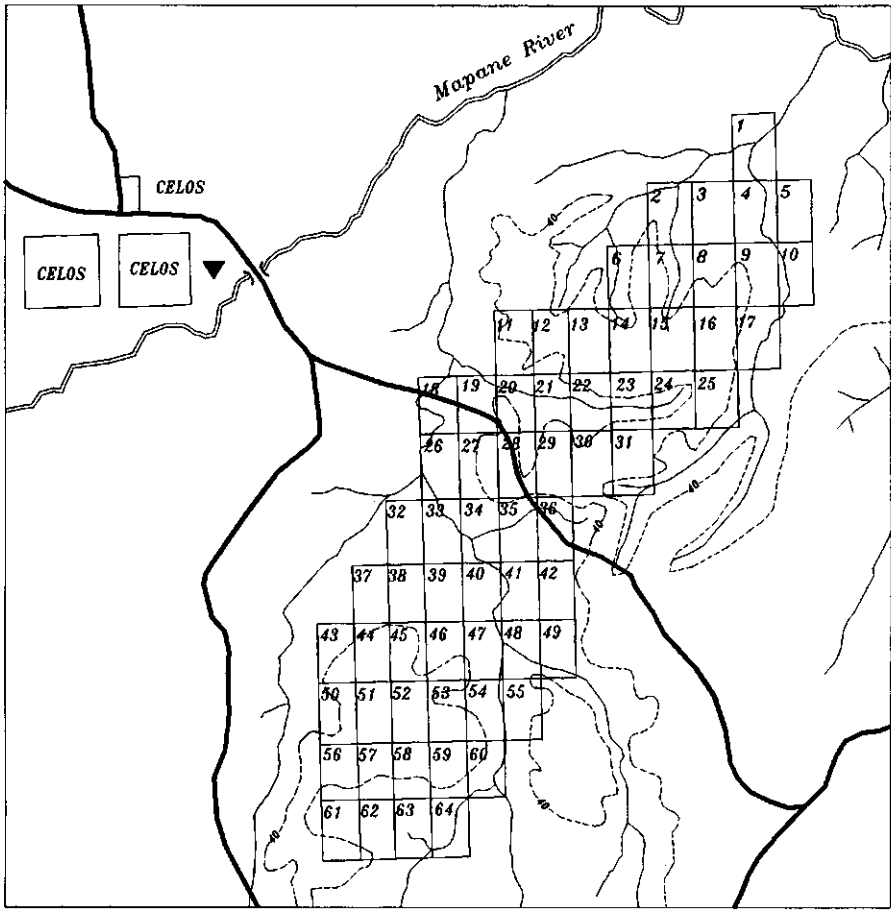
Located between the Suriname and Commewijne rivers (Fig. 3.1), the Mapane region is crossed from west to east by the Mapane River, a tributary of the Commewijne River originating in the southern hills of the Forestry Belt. The forest road network, between Joden Savanne and Auca on the Suriname River and Java on the Commewijne River, gives excellent access to the forests allocated for timber production. As part of the inspection network, the Forest Service has established log landings and forest guard stations at these three settlements. The river yards are important collection points for log transport to the processing industries in the coastal area.

At one of the Forest Service settlements, Akinto Soela, CELOS started a

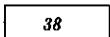


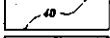

TABLE 3.3. Mapane region: forest types

| Forest type          | Forest area |       |
|----------------------|-------------|-------|
|                      | (ha)        | (%)   |
| Rain forest          | 47 000      | 68.1  |
| Marsh forest         | 11 000      | 15.9  |
| High savannah forest | 5 000       | 7.2   |
| Open savannahs       | 1 000       | 1.5   |
| Liana forest         | 1 000       | 1.5   |
| Pine plantations     | 4 000       | 5.8   |
| Total                | 69 000      | 100.0 |

Source: LBB Statistics



Legend

-  number inventory unit
-  creek
-  forest road
-  contour line, 40 m above sea level
-  Akinto Soela

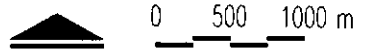


Fig. 3.5 Mapane research area: inventory grid

silvicultural research programme in 1967 (de Graaf, 1986). A few kilometres to the east, in 1980 the Forest Service marked out an area of approximately 1000 ha for natural regeneration studies (Fig. 3.5). On the basis of previous surveys (Schulz, 1960; de Boer, 1981), this location was selected for field scale silvicultural investi-

gation, because both forest and soil are representative of the Mapane region (de Vletter, 1980). Thus it was a logical step to integrate the CELOS harvesting research with the Forest Service silvicultural research, since both are components of the same management system.

A wooden bridge constructed across the Suriname River at Point Carolina has improved the road system thus increasing the value of the area as a forest management zone and also as a centre for forestry research, because of the easy access with institutes in Paramaribo. Another advantage is the supply of labourers for all types of forest operations from the Amerindian villages at Joden Savanne and Cassipora.

The research site is east of Akinto Soela (Fig. 3.5). The area is crossed by two small tributaries of the Mapane River which form the catchment basin of the forest. These are permanent streams except for the northern tributary which dries up in very dry seasons only.

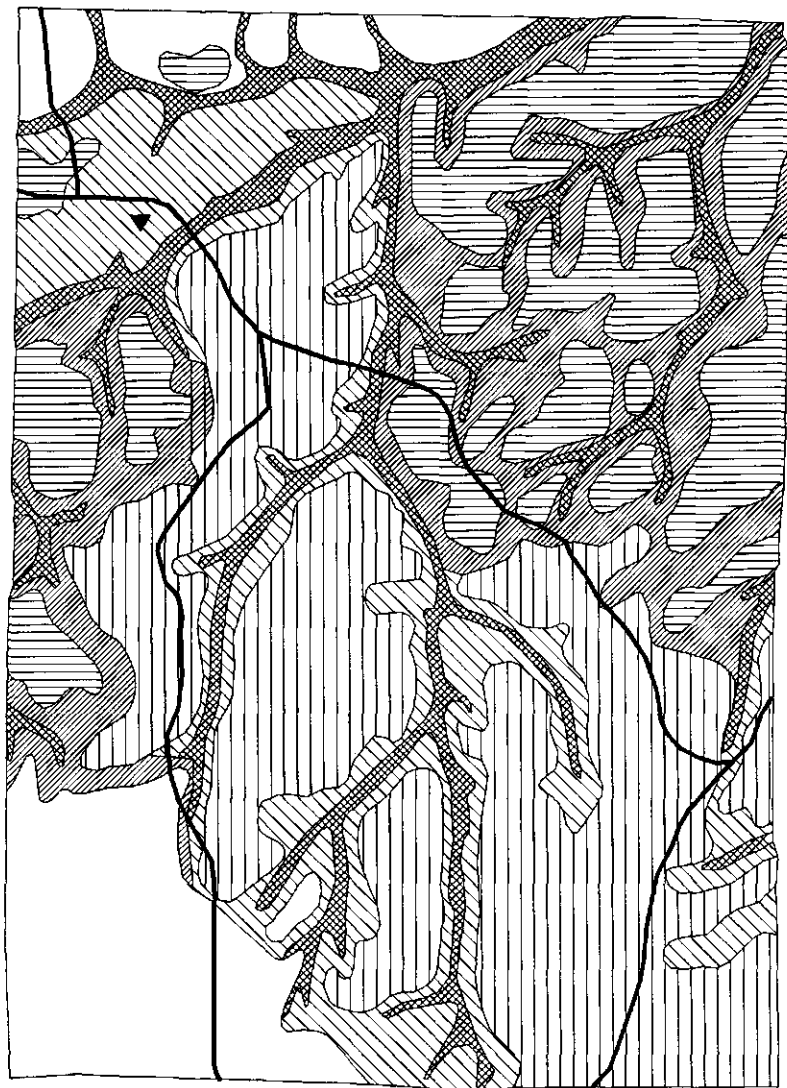
### *3.2.2 Soil and landscape*

The soils in the Mapane region belong to either the Zanderij formation or to the old basement complex. The dominant soil types are Ferralsols (lateritic soils) or Oxisols often with a high percentage of clay (de Boer, 1981; Poels 1987). They are reddish or yellowish in colour and weathered to a considerable depth (see Buringh, 1979). The texture of the Zanderij formation varies from sands to sandy clay loams, and that of the basement soils from sandy clay to clay. The drainage is good and the structure stable. The soils are old, very low in exchangeable minerals, and mostly covered with high forest. Soil profiles rarely show distinctive horizon boundaries. The O-horizon on top of the mineral soil consists of organic matter of 1-3 cm thickness is constantly in a process of decomposition. The mineral soil has an ochric A-horizon and a deep oxic B-horizon. The ironstone outcrops throughout the Forestry Belt provide gravel for road construction.

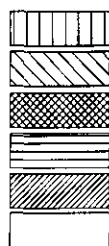
The second soil type in the Mapane region are the white sands (Albic Arenosols) which are covered by open, poor savannah vegetation or by low forest. These soils consist of excessively drained and bleached sands (white sand savannahs). Their lower horizons are sometimes impermeable because of the accumulation of leached iron components, which may result in dryness in the upper layers in the dry season and a high groundwater level in the wet season (Cohen and van der Eyck, 1953).

The third soil type are Fluvisols, alluvial deposits of rivers and creeks (de Boer, 1972). The structure and texture are largely determined by deposited sediments and by the groundwater level. In the Mapane region, these soils are often poorly drained and some parts show characteristics of swamps and marshes. On the terraces along the large rivers these soils are well drained and suitable for cultivation of various food crops.

High forest tends to occur on uplands on Ferralsols (20-40 m above sea level),



Legend



Tibiti: plateau soils  
 Tibiti: creek valley soils  
 Tibiti/Rama: footslope soils  
 Rama: plateau soils  
 Rama: slope soils  
 other landscapes



forest road  
 Akinto Soela



0 500 1000 m

Fig. 3.6 Mapane research area: dominant landscape types

creek forest on Fluvisols along the numerous streams and in valleys, and savannah forest on arenosolic plateaus (30-40 m above sea level). More detailed observation shows considerable variation in sub-soil types, topographic features and vegetation types. The major landscape types in the Mapane region are discussed according to the classification system developed by de Boer (1981) for the northern part of Suriname.

*Tibiti landscape.* The plateau and hilltop soils comprise moderately well to imperfectly drained sandy loams, often over sandy clays. Ironstone is present in some places. On the slopes towards the creeks there is a transitional zone of similar soil characteristics, but drainage and texture show a gradual change. Slope soils are imperfectly drained and on the footslope soils consist of poorly drained sands and sandy loams, and sandy clays. The Tibiti landscape is typical for the Mapane region.

*Rama landscape.* Another dominant landscape, the Rama landscape, consists of well drained, mostly gravelled clay hilltop and plateau soils and slope soils of moderately to well drained (gravelled) clay. In the valleys and on footslopes where the drainage is again poor, soils consist of medium and coarse sands and sandy loams, often over clay.

*Dek landscape.* This is a typical savannah landscape consisting of excessively drained, bleached medium and coarse sands and imperfectly drained, bleached medium and coarse sands.

Further to the south landscapes are hilly. Hilltop soils are well drained and contain very gravelled clay with ironstone at the surface in some places. The terrain data collected during the preliminary stage of the harvesting research were used to locate logging experiments in the two dominant landscapes: Tibiti and Rama landscapes as shown in Fig.3.6.

### 3.2.3 Harvesting practices

Harvesting activities in the Mapane management zone started in about 1957 after the main forest roads had been built. About 30 concessions varying in area from 1600 to 6400 ha were granted to private entrepreneurs under the stipulations of the Timber Ordinance. In the period, 1957-1970, only eight timber species were harvested. Log production was approximately 8-10 m<sup>3</sup>/ha, according to the records of Forest Service Inspection Division. By 1970 most of the concessions had been creamed off by this selective exploitation (ILACO, 1977), and only two concessions in the south were still being harvested in 1981. The others had been abandoned or closed temporarily until market demand increased for lesser known



species. The truck roads were in good condition and were graded regularly by the Forest Service.

The research site is located in a forest which was logged 10 years ago, and thus commercial stock was probably lower than that of the original (pristine) forest. The trees had been felled with power saws, and logs extracted with articulated wheeled skidders. To describe the starting point of the harvesting and stand damage studies accurately, the logging impacts on the quality of the remaining stand had to be determined and therefore an appraisal of the first timber harvest was included in the present study (Sections 3.3.4 and 4.1).

### **3.3 Stand damage studies**

In the present study, an in-depth investigation has been done on the stress-strain relationship between damaging factors and effects on the forest ecosystem and on single trees of both the controlled and conventional logging systems (see Table 1.1). The methodology for this study is discussed in the following sections.

#### *3.3.1 Research conditions and limitations*

The harvesting studies aimed to contribute to the development of a sustained yield management system. The high physical and financial inputs required, largely determined the practical and economic set-up of the study. Machinery and skilled staff were made available by CELOS, the Forest Service and a private concessionaire. An area of 1000 ha forest was allocated by the Forest Service to test the CELOS Silvicultural System (de Vletter, 1980). A private logger was contracted by the Forest Service and CELOS for felling and skidding work. Field-workers and supervisory staff were recruited from the cooperating organizations. The following set-up was agreed:

- *Integrated studies.* Since the field-work was carried out in the Forest Service silvicultural research site, harvesting and silvicultural studies were integrated in many respects. The same equipment and inventory data were used in both studies but the harvesting study was restricted by management targets set previously by the Forest Service. Firstly, the logging intensity was set at 15-20 m<sup>3</sup>/ha, and secondly, the inventory network and silvicultural treatment scheme had been determined according to de Graaf's 'list of operations' (de Graaf, 1986). The fixed logging intensity meant that relationship to harvesting damage, as examined by Jonkers (1987) in Kabo, could not be checked at the experimental sites in Mapane.
- *Restricted interference in commercial operations.* The research area was to be logged by a private concessionaire on a commercial basis, but following a strict regime for that part of the area designed for control logging operations. In the

other part, operations were observed without interfering with the work of the concessionnaire. An agreement was made for fully controlled logging trials, such as winch logging (see Chapter 6). Observation of commercial operations provided more reliable insight into current logging practices. Possible drawbacks were dependence on an external organization and consequently the risk of undesired delays in the research programme.

- *Harvesting regulations.* These were stipulated to serve the logging and silvicultural objectives and also designed to be executable by the concessionnaire. The basic regulations for harvestable timber species, minimum allowable diameter and felling and transport, were adopted from the Timber Ordinance (see Section 2.3). The list of harvestable species was the 'CELOS list of commercial species' (de Graaf, 1986; Jonkers, 1987) presented in Appendix III.

### 3.3.2 Experimental layout

The research site is accessible by a forest road, which divides the area into a southern part dominated by the Tibiti landscape and a northern part dominated by the Rama landscape. The research site is fairly well opened for harvesting operations, especially the south which is accessible from two directions.

The site was divided by the Forest Service into rectangular inventory units of 250 × 400 m (10 ha). At the confluence of the creeks, a north-south and an east-west line were cut as baselines of a grid. A width of two metres was cleared along the north-south line to give access to the research area. From the baseline, border lines of one metre width were cut. The corners of the units were numbered with aluminium labels fixed on wooden pickets. A network of 64 inventory units was established (see Fig. 3.5).

The inventory grid was used to demarcate eight experimental logging compart-

TABLE 3.4. Mapane research area: assignment of treatments to experimental compartments

| Compartment | Area (ha) | Treatment                                   |
|-------------|-----------|---|
| 1,1         | 20        | conventional logging                        |
| 1,2         | 20        |   |
| 2,1         | 10        | controlled logging with directional felling |
| 2,2         | 10        |   |
| 3,1         | 10        | controlled logging                          |
| 3,2         | 10        |   |
| 4,1         | 20        | controlled logging with winching            |
| 4,2         | 10        |   |

ments, representing four logging treatments (Table 3.4). The logging treatments were not randomly assigned to the experimental logging compartments because of the variation in site characteristics. The statistical set-up of an observational study (Snedecor and Cochran, 1980) was chosen by systematically allocating of experimental compartments in areas where conventional and controlled logging were to be done. The experimental compartments were chosen on the basis of similarity in stand and terrain factors to exclude the effects of other factors. The site characteristics of the compartments are listed in Table 3.5.

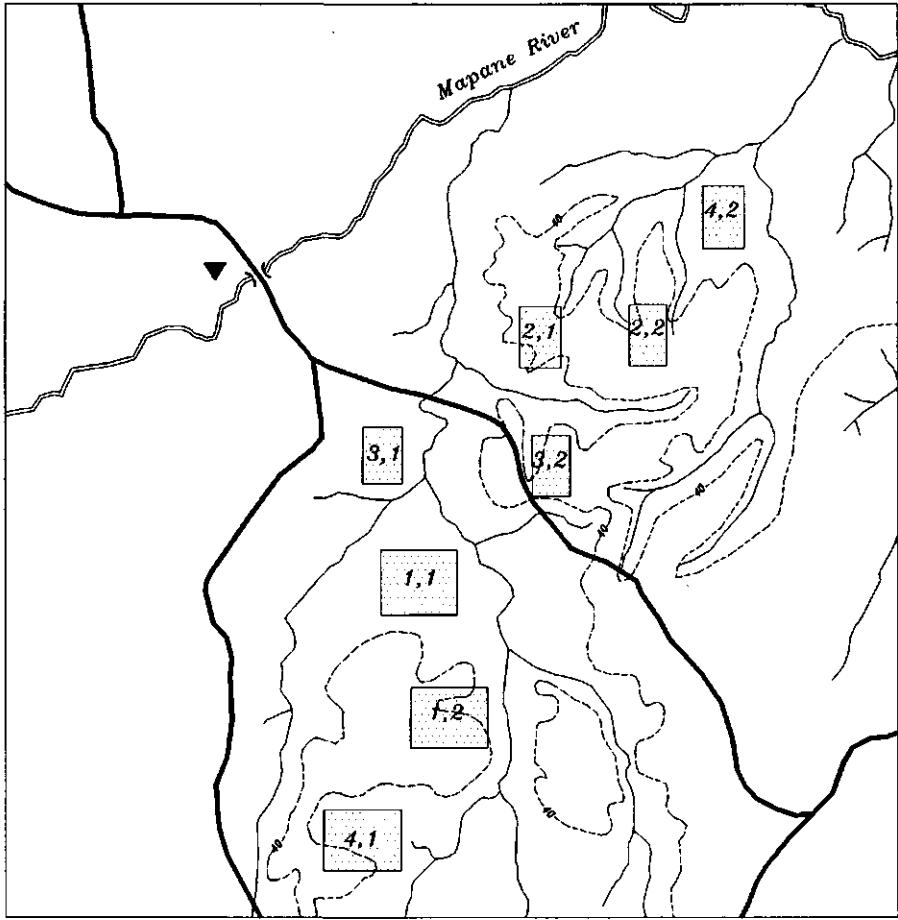
Each treatment was done in duplicate as indicated by the indices 1 or 2 (see Fig. 3.7). The experimental compartments as listed in Table 3.4 were laid out as a harvesting entity, each with its own felling regime and skid trail system. Compartment boundaries coincided with north-south and east-west lines of the inventory units. For purposes of statistical analysis an experimental compartment was defined as a block receiving a specific logging treatment.

TABLE 3.5. Mapane research area: stand and site characteristics in the experimental compartments

| Compartment | Basal area*<br>(m <sup>2</sup> /ha) | Mean dbh**<br>(cm) | Terrain slope<br>(%) | Soil texture  | Soil drainage      |
|-------------|-------------------------------------|--------------------|----------------------|---------------|--------------------|
| 1,1         | 24.8                                | 56.4               | 2- 8                 | sandy loam    | well drained       |
| 1,2         | 22.7                                | 53.2               | 4- 8                 | sandy loam    | moderately drained |
| 2,1         | 23.5                                | 55.5               | 4-12                 | gravelly clay | well drained       |
| 2,2         | 24.2                                | 56.1               | 4-10                 | gravelly clay | well drained       |
| 3,1         | 24.1                                | 54.8               | 2-10                 | sandy loam    | moderately drained |
| 3,2         | 21.9                                | 52.7               | 2- 8                 | sandy loam    | well drained       |
| 4,1         | 22.8                                | 51.9               | 4-10                 | sandy loam    | well drained       |
| 4,2         | 23.6                                | 55.6               | 6-14                 | gravelly clay | well drained       |

\* All trees > 35 cm dbh

\*\* Harvestable trees > 35 cm dbh



Legend

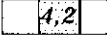

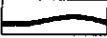


-  experimental compartment
-  creek
-  forest road
-  contour line, 40 m above sea level
-  Akinto Soela



Fig. 3.7 Mapane research area: experimental layout

### 3.3.3 Logging treatments

Two major types of logging treatments were distinguished: uncontrolled and controlled (for definitions, see Sections 1.2 and 3.1). Uncontrolled logging represents the conventional logging system and is statistically comparable with a 'null-treatment'. In the experiments, three levels of controlled logging were applied. The level of control was increased with respect to planning and performance of ground skidding operations. The four 'logging treatments' are listed in Table 3.3.

Two experimental compartments each of 20 ha were designated for conventional logging in the south of the research area where the concessionaire carried out harvesting operations in the usual way. Felling and skidding activities were recorded and stand damage measured.

Controlled logging was studied in four compartments, each of 10 ha, located in the north of the research area. These compartments were harvested by a contractor according to a strict scheme. The effects of controlled and directional felling (for description see Sections 3.1.1 and 3.1.2) were investigated in two of these compartments.

In addition, two units, one of 20 ha in the south and the other of 10 ha in the north of the forest, were used to study controlled logging with timber extraction by winching. The work was executed by CELOS and the Forest Service staff with equipment on lease.

### 3.3.4 Inventories

The general inventory of the Forestry Belt made by the Forest Service during the 1950s was used to obtain information on the northern pristine rain forests of Suriname. In this inventory, commercial trees were enumerated in 10 m wide lines in east-west direction at 500 m intervals in inventory blocks of 4 x 4 km. Only 2% of the forest area was sampled because the main aim of the general inventory was to provide a basis for forest policy and means of control for the Forest Service (Bubberman, 1980). This inventory, also including a full enumeration of commercial species on a sampled area of 25 ha, was used to assess the original forest composition in the research area (Section 4.1).

*Topographic survey.* A reconnaissance level survey was carried out to prepare a terrain map (scale 1:5000) of the research site. Topographic features were recorded such as water courses, swampy sites, hill slopes, gullies and boulders. Tree stumps from earlier timber harvesting were enumerated to assess the logging intensity, and old skid trails were traced and mapped. The impact of the first timber harvest is discussed in Section 4.1.

*Silvicultural enumerations.* As part of the Forest Service research programme,

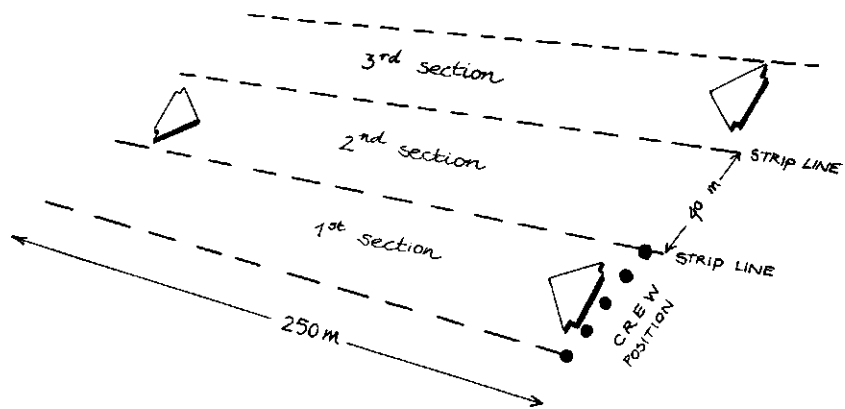


Fig. 3.8 Prospecting method

information had been collected in the research area on the number and dimensions of commercial species and of seedlings, saplings and trees in order to plan silvicultural treatments. This inventory was completed six months before the start of harvesting activities. Data were collected in all inventory units and in 13 randomly selected permanent sampling plots (PSP) each of 1.0 ha. The plot design was adapted from Synnott (1979) as part of the inventory grid. The following enumerations were carried out:

- Saplings and small trees between two and fifteen cm dbh were enumerated in three randomly selected subplots of 10 x 10 m in each PSP.
- All tree species of 15 cm dbh and above were enumerated in all PSP's. Tree diameter was measured with a tape or calliper and tree height with a Blume Leisz clinometer. The quality of every tree was assessed, and registered in a quality code.
- Commercial species were enumerated in a strip of 40 x 250 m in each inventory unit of 10 ha in order to assess basal area. The strip was located in an east-west direction along the southern boundary of the unit and divided into one subplot of 40 x 50 m (2.5% of the total area) and another of 40 x 200 m (8% of the total area). In the first plot, all commercial trees of more than 5 cm dbh, and in the second, all commercial trees of more than 10 cm dbh were measured.

*Harvesting inventory.* In all 64 inventory units commercial species of harvestable size, that is of minimum dbh of 35 cm, were enumerated. These data were needed to prepare maps and working plans for harvesting operations, including harvesting regulations, tree location maps and production plans. This complete inventory of harvestable trees, known as prospecting or 100% tally (Husch, 1971), was carried out in four steps as follows:

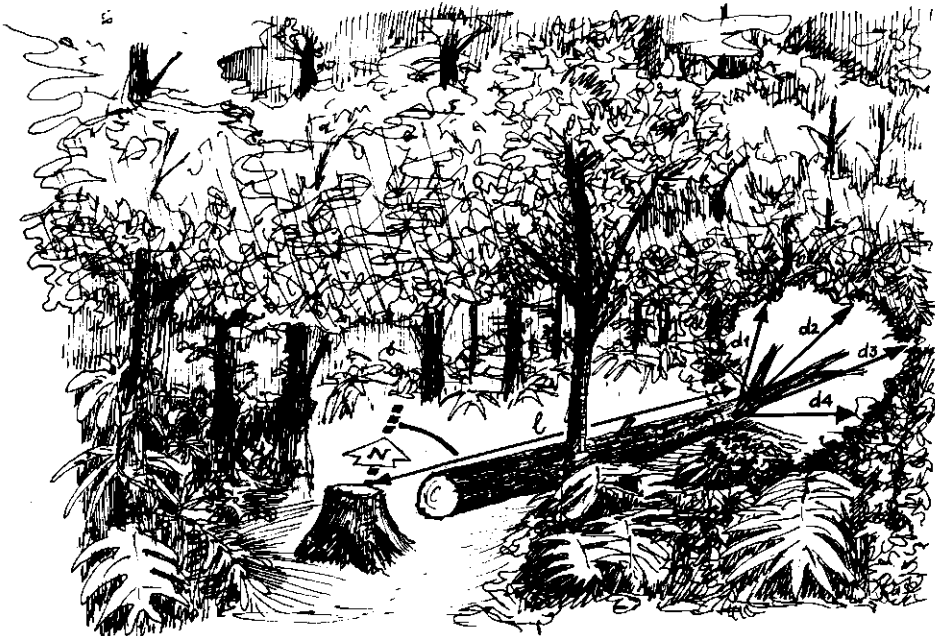
- The area was enumerated unit by unit. Each unit was divided into ten sections each of 40 x 250 m. A crew of five tree spotters started in the first section from a position along the north-south boundary. The crew members were spaced 10 m apart with a foreman in the middle (see Fig. 3.8).
- At a signal from the foreman, the crew moved in an east-west direction across the unit. It is important that the tree spotters move slowly and at the same speed. While walking, tree spotter number one signalled picket distances marked on the east-west boundary to the foreman and to tree spotter number five who cut a new line and marked the distances with pickets.
- When a commercial tree was observed, the spotter signalled the crew to halt. The tree was identified, numbered and the diameter and height assessed. These data were given in code to the foreman who recorded the tree location and number on a predesigned map and tree dimensions on a form (also see Section 3.5.1).

- On reaching the unit boundary, the crew moved to the next 40 x 250 m section, and the procedure was repeated in opposite direction (west-east).

A unit was completed in 10 passes. An experienced crew can cover two units (each of 10 ha) within a day. Data on trees and topography were recorded simultaneously.

### 3.3.5 Assessment and classification of felling damage

For the purpose of this study, felling damage was taken to be the size of the gap in the forest vegetation formed by a felled tree (see Section 1.3.1). Felling gaps were mapped, firstly by plotting the boundaries of the affected area, including an extra five metres around the (visible) damaged vegetation, and then by measuring the location of the fallen crown and radii of the gap (see Fig. 3.9). The stump was used as reference point in determining the orientation of the gap with a compass and measuring the distance to the crown with a tape. The procedure was facilitated by using graph paper, each square representing a section of 1 x 1 m. The area of the



Legend

$d_1 - d_4$  gap radii

$\ell$  distance from stump

Fig. 3.9 Measuring a felling gap



gap was calculated in the office using an overlay screen or a planimeter. This measuring method was tested in a logging compartment containing 34 gaps, varying in size from 90 to 580 m<sup>2</sup>, and was subsequently used as a standard method in all experimental compartments. In order to compare gap areas caused by various felling regimes, all measurements were done by the same crew of a foreman and two assistants.

Gap size proved to be a practical parameter for assessing felling damage and for comparing the impact of logging. The more intensive enumeration of damaged trees was restricted to randomly selected felling gaps, where all damaged trees exceeding 20 cm dbh were recorded within the gap boundary. In total 32 gaps (approximately 5% of the mapped gaps) were enumerated. In five of these gaps the recording was extended to small trees above 5 cm dbh. The diameter at reference height was measured and tree injuries assessed using the following classification:

- Class 1: no injury - no visible stem or crown damage;
- Class 2: minor injury - visible injury on stem and/or crown from which the tree is expected to recover;
- Class 3: severe injury - extensive injury on stem or crown from which the tree is not expected to recover. This category includes completely destroyed and uprooted trees.

This classification system derived from Jonkers (1984) enabled quick and accurate recording. Felling impacts are discussed in Section 4.2.

### *3.3.6 Assessment of skidding damage*

Skidding damage was assessed by mapping the entire skid trail system in each experimental compartment. The standard mapping procedure involved a compass and tape (or theodolite and beacon) to measure the pattern, length and width of the trails. Primary (main) and secondary (branch) trails as well as skidding gaps near tree stumps were identified, measured and mapped. Avoidable skidding damage was determined by assessing the efficiency of the trail system including the location, trafficability and density of the trail network in relation to access and transport function. Other criteria, such as sharp curves in trails and creek crossings, were also mapped or recorded. Skidding gaps made by a skidder in the stump area are avoidable and hence were considered to be damage.

*Conventional skidding* was done without planning and without an established trail system. The skidder operator was not given a map showing the location of logs and terrain difficulties. The trail network formed during log extraction was mapped after the experimental compartments had been harvested. The working method of the skidder operator was observed to obtain more insight into uncontrolled trail

forming. The travelling intensity of skidders on primary and secondary trails was also recorded.

*Controlled skidding* was based on a planned trail network for ground skidding which was established prior to harvesting. The standard mapping procedure was used in the two experiments: with and without directional felling. The actual pattern of the trail network was compared with the original design to assess the degree of damage and efficiency. Traffic intensity was also recorded.

*Controlled winching* was based on controlled logging but logs were partly extracted from stump to trail with the winch system of a skidder. The constructed trails and skidding damage were mapped in the same way as in the other controlled experiments.

Bark damage on trees along skid trails was also recorded and classified using the same system as for felling damage. This form of damage was caused by the skidder or by sweeping movement of the extracted logs. Stand damage resulting from skidding is discussed in Section 4.3.

### *3.3.7 Assessment of wood damage*

Three types of damage to the harvested product were recorded: natural defects, felling and skidding injuries, and deterioration of logs during storage. Wood damage caused by operational factors comprises loss of production and should, therefore, be considered as logging damage (see Table 1.1).

Trees may split or break as a result of improper felling and rough skidding. Some timber species are very susceptible to damage and even careful felling may cause splits, internal cracks or complete breaks. Such defects were recorded on the felling and skidding forms by the foremen. A log rejected for this reason was coded 'D' (see Section 3.5.1).

Wood quality differs from species to species and may even vary considerably within a species. Visually sound trees may have internal defects which render them worthless in the timber trade. Some species have a high percentage of heart rot, internal splits or brittle parts. Rain forests frequently contain mature trees which have deteriorated and consequently are of no interest for harvesting (de Milde and Inglis, 1974b). Defective trees identified during prospecting were marked and recorded on the prospecting form to prevent felling and senseless forest damage. Felled trees with serious natural defects were recorded in the felling forms by code 'C' (see Section 3.5.1).

Timber harvesting is a continuous process of felling, skidding and long-distance transport. To guarantee continuity, buffer stocks should be kept in stump areas and on forest and river landings. However, large stocks may mean loss of interest

and a risk of deterioration. Extended storage sometimes requires logs being chemically treated against insects and fungi, which increases logging cost. Regular transport of logs to processing centres is a better means to control stocks rather than treatment with preservatives. After the harvesting operations had been completed a survey was carried out to assess the proportion of deteriorated logs in stump areas and on landings. Wood damage is discussed in Section 4.4.

### **3.4 Soil damage studies**

Tractive skidding is the only mechanized logging method presently used in Suriname. Terrain conditions in the Forestry Belt are favourable for skidding operations except in the south-east where the landscape is more hilly. Cable yarding systems, as used formerly in the swamp forests, are apparently not economical in lightly stocked hill forests.

The successful introduction of wheeled skidders (Fig 3.4) in the late 1960s changed terrain transport to some extent. The expensive and slow crawler tractor was largely replaced by the more manoeuvrable and faster wheeled skidder, especially in small-scale operations with only one or two machines. The wheeled skidder proved to be an attractive machine, having lower maintenance costs than the crawler and a larger economic skidding distance. However, this machine also has some disadvantages, the main one being decreasing performance on soils of low bearing capacity. This problem was not investigated, but it has been reported that wheeled skidders could not operate on the sandy loams in the Patamacca forest estate in the rainy season, on sites where crawler tractors were used throughout the year (BSH, 1982).

In addition to the trafficability problem, wheeled skidders may seriously damage forest soil (see Section 1.3.2 and Table 1.1), such as disturbance and compaction of the topsoil with possible effects as erosion, water pollution and landscape deterioration. As these problems occur on various sites in the Forestry Belt, it was important to investigate skidder impact on dominant soil types in the Mapane area. Moreover, the need to reduce this type of damage in sustained yield management justified this research. Because of the limited facilities to conduct such studies in Suriname, only compaction in and disturbance on skid trails were examined.

#### **3.4.1 Test area**

The skid trails for the soil tests in the Mapane research area were surveyed to determine the number and locations for observation. Two primary skid trails used two years previously and a further two primary trails used eight years previously were selected to study soil recovery from compaction by skidder movement. The effects of log collection in the stump area were studied on two secondary skid trails

one month after logging. Two unused primary skid trails were assigned to test the impact of travelling intensity of a loaded wheeled skidder.

### 3.4.2 Field and laboratory tests

Field and laboratory tests were carried out with assistance of the Laboratory for Soil Research (Agricultural Experimental Station Paramaribo). Soil samples were taken systematically over a distance of 200 m on selected skid trails. Along each trail 10-20 undisturbed volumetric core samples were taken in cylindrical steel rings of 100 cm<sup>3</sup> and 400 cm<sup>3</sup> in the wheel ruts (R1 and R3), between the ruts where the load was skidded (R2), and for comparison in the undisturbed forest soils (U). The ground level of the undisturbed soil was taken as reference level for sample depth. The first sample in a rut was taken approximately 5 cm below reference level and samples were collected to a depth of 70 cm. The samples were sealed and transported to the laboratory where they were weighed and gravimetric field moisture content determined. Dry bulk density was calculated as the mass of the soil after drying at 105 °C.

Another set of soil samples of 1-2 kg each was collected in pits in various soil profiles to determine soil composition (texture). These samples were sealed in plastic bags and used in the laboratory for sieve analysis and sedimentation tests.

The 100 cm<sup>3</sup> samples were used to determine water retention (pF curve) and saturated hydraulic conductivity (K factor), a parameter to assess vertical water flow through soil horizons. Measured under laboratory conditions on a vertical soil column, the K factor is regarded as a useful indicator for structural disturbance of the skid trail. Both tests were carried out with standard laboratory equipment (see Hillel, 1980; Koorevaar et al., 1983)

In addition to soil sampling, soil resistance to penetration (soil strength) was studied with a self-recording hand-operated penetrometer with a cone surface of 1 cm<sup>2</sup> and a tip angle of 30°. The penetration resistance (cone index value) was recorded in N/cm<sup>2</sup>. This method gives an indication of soil strength and compaction, but penetration resistance is a complex function of factors including soil density (soil compaction), moisture content, texture and type of clay minerals (Soane, 1981a). The relationship between the cone index and ratio of soil compaction is not known and may differ from soil type to soil type. Penetration resistance was measured according to the same scheme of soil sampling.

Ruts deeper than 5 cm were examined as a factor of soil disturbance. The cross profiles of these ruts were measured with a calibrated vertical needle in combination with a level instrument to determine tyre penetration and degree of soil disturbance. This measurement also provided an indication of trafficability of the skid trails.

### *3.4.3 Traffic intensity test*

Changes in soil density and penetration strength as a result of traffic intensity were studied on two new skid trails, especially opened for a controlled experiment. A Clark 666 C wheeled skidder (see Table 3.2 for specification) was used. The skidder travelled down the trail from a fixed starting point with a standard load of 4.2 tonnes (two logs of 11 m length and 55 cm diameter) in second gear at an average speed of 2.6 km/h. The maximum slope of the trail was 5%. After passing the observed trail section, the skidder returned via another trail to the starting point. After each pass the observation points were sampled for penetration strength and bulk density. The first roundtrip with an unloaded skidder was followed by eight roundtrips with standard load.

## **3.5 Logging efficiency studies**

Damage-controlled logging aims to prevent and restrict stand damage in commercial harvesting operations. In the first instance such logging systems are concerned more with planning forest operations than with the application of modern technology, although the latter might also contribute to damage restriction. Damage-controlled logging should be efficient and affordable, and especially in developing countries, preferably less expensive than conventional logging.

The three examined logging methods, damage-controlled (experimental logging), semi-controlled (BSH logging) and uncontrolled (conventional logging), were compared for efficiency of operations. For this purpose, an administrative procedure to collect information on felling and skidding production was developed. The results of the study are discussed in Chapter 6.

### *3.5.1 Production and time records*

Data were collected through a registration system designed to follow production and to generate information for day-to-day management. The system which was followed strictly in all logging experiments was simple and could easily be handled by the harvesting crews. The registration system was based on a metal disk number on the log cross-section, here referred to as log number, which was visible throughout transport from forest to mill. Four forms were used to record major harvesting operations of prospecting, felling, terrain transport (skidding) and long distance transport (see Fig. 3.10). The field forms were collected and processed regularly so that the log flow could be followed accurately. A computer programme was designed to calculate daily production at each stage of the harvesting process.

| <i>Prospecting form</i> |                        |                     |                 | <i>Inventory unit no. 14</i>    |              |
|-------------------------|------------------------|---------------------|-----------------|---------------------------------|--------------|
| <i>Date: 03.03.83</i>   |                        |                     |                 | <i>Logging compartment: 1,1</i> |              |
| <i>Tree no.</i>         | <i>Vernacular name</i> | <i>Species code</i> | <i>DBH (cm)</i> | <i>Length (m)</i>               | <i>Notes</i> |
| 31                      | Kopi                   |                     | 85              | 15.9                            | C (reject)   |
| 36                      | Kopi                   |                     | 63              | 18.2                            |              |
| 33                      | Wana                   |                     | 76              | 17.5                            |              |
| 34                      | Ceder                  |                     | 51              | 8.1                             |              |
|                         |                        |                     |                 |                                 |              |

| <i>Felling Form</i>   |                |                   |                      | <i>Inventory unit no. 14</i>    |               |                |              |
|-----------------------|----------------|-------------------|----------------------|---------------------------------|---------------|----------------|--------------|
| <i>Date: 10.21.83</i> |                |                   |                      | <i>Logging compartment: 1,1</i> |               |                |              |
| <i>Tree no.</i>       | <i>Log no.</i> | <i>D-top (cm)</i> | <i>D-bottom (cm)</i> | <i>Length (m)</i>               | <i>Buttr.</i> | <i>Quality</i> | <i>Notes</i> |
| 32                    | 0829           |                   |                      |                                 |               |                |              |
| 30                    | 0830           |                   |                      |                                 |               |                |              |
| 33                    | 0831           |                   |                      |                                 |               |                |              |
| 36                    | 0832           | 50                | 61                   | 9.1                             | 0             | B              | lions        |
| 36                    | 0833           | 62                | 69                   | 8.0                             | 0             | B              |              |

| <i>Skidding form</i>  |                 |                 | <i>Logging compartment: 1,1</i> |                |                    |              |
|-----------------------|-----------------|-----------------|---------------------------------|----------------|--------------------|--------------|
| <i>Date: 11.04.83</i> |                 |                 |                                 |                |                    |              |
| <i>Log no.</i>        | <i>Trip no.</i> | <i>Load (n)</i> | <i>Distance (m) to</i>          |                | <i>Trail class</i> | <i>Notes</i> |
|                       |                 |                 | <i>Trail</i>                    | <i>Landing</i> |                    |              |
| 0849                  | 6               |                 |                                 |                |                    |              |
| 0845                  | 6               |                 |                                 |                |                    |              |
| 0831                  | 6               | 3               | 30                              | 750            | good               |              |
| 0830                  | 8               |                 | 32                              |                |                    |              |
| 0833                  | 8               | 2               | 41                              | 820            | average            |              |

| <i>Transport form</i> |                 |                 | <i>Landing: A(1,1)</i>  |              |              |
|-----------------------|-----------------|-----------------|-------------------------|--------------|--------------|
| <i>Date: 11.07.83</i> |                 |                 |                         |              |              |
| <i>Log no.</i>        | <i>Trip no.</i> | <i>Load (n)</i> | <i>Distance (km) to</i> |              | <i>Notes</i> |
|                       |                 |                 | <i>River</i>            | <i>Plant</i> |              |
| 0833                  | 4               |                 | 35                      |              |              |

Fig. 3.10 Recording forms

*Prospecting form* was used to record information on trees of commercial species. The crew identified trees in the forest by their vernacular name, and later in the office the scientific name was recorded in code. The crew assessed the tree diameter in centimetres at the reference height of 1.30 m or one metre above the buttresses, and the length of usable bole in metres, in most cases the tree section between the bud and the first branches. The prospecting data were sufficiently accurate to calculate the standing volume of commercial species in cubic metres, that is the potentially available gross volume. Trees with serious visible defects were recorded as rejects and marked with a blue cross indicating that they should not be felled. The occurrence of lianas on an enumerated tree was also recorded.

*Felling form* was used to register felling production. Depending on the length of the bole, trees were topped and bucked into one, two or three sections or logs, each of which was numbered with a disk. Logs are the timber products and the unusable parts of the tree (crown, branches, stump, defect parts) are called as residue or debris. Rejected logs were also measured in order to calculate the felling ratio. The top and bottom diameters of a log were measured with a calliper and the log length with a tape. Log quality was coded as follows: A = first quality; B = second quality; C = reject because of natural defects; and D = reject because of felling defects. The occurrence of buttresses was recorded as 0 = no or small buttresses and 1 = significant buttressess. At the office the skidding distance from stump to the landing was calculated from the tree location map. These records were needed to calculate felling production by species and by quality class. For a more accurate calculation of log volumes a detailed scaling was carried out by measuring logs in sections of 3 m length. About 600 logs were measured in this way.

*Skidding and transport forms* were used to record log numbers as well as the trip numbers of skidders and trucks. These data were used to calculate production and to investigate skidding factors and variables. The effect of payload, trail standard, and skidding distance on round trip time and skidding production were also studied. This was detailed for a standard load of 4 tonnes and a skidding distance of 800 m (see Section 6.2).

*Time recording* was part of the general administration and was combined with production records. All relevant activities of a working day were registered such as travel, effective working, machine time, delays and machine maintenance. In addition, studies were carried out to obtain more detailed information on the time distribution in a working cycle, for instance, the proportions of spotting, preparation, felling, bucking and scaling time in a (felling) working cycle.

Standard terminology of FAO (1978) was used to describe various operations. The time that determines production is referred to as the effective working time or effective operational time. For manual labour, the effective working time is man or crew time actually spent at the site to perform a specific task, for example tree

felling with an axe or power saw. This does not include crew's down time that is travel time to and from the site, scheduled meal breaks and daily maintenance of tools. As a rule, the effective crew time is the difference between the working day (number of paid hours) and the crew's down time. In the logging experiments, effective working time was recorded as effective crew time, denoting that operations were carried out by a number of workers.

The effective machine time is when the machine is actively working and in the case of a tractor engaged in off-road transport, includes both loaded and unloaded travel as well as time for picking up or dumping the load. Machine's down time for daily routine servicing and refuelling are not included, but delays such as waiting for logs to be ready for extraction are (FAO, 1978).

Although determined largely by climatic factors, effective crew time and machine time can be used as criteria for efficiency for comparison of two systems under similar site and climatic conditions. In practice, there are seldom more than 175 days per year for well planned forest exploitation (FAO, 1974). In Suriname, rain is not evenly distributed throughout the year, but forest work is not hampered substantially during the long (four months) and short (two months) rainy season. Fraser (1981) assessed the number of effective working days for Suriname forest operations to be 150 for modern enterprises, such as BSH, and less than 125 for small concessions, the difference is attributed to organizational factors.

*Additional information on commercial harvesting practices* in Suriname was collected by interviews and analysis of secondary (administrative) data. In total 12 concessionaires and sawmill owners were interviewed to obtain information on management, administration and economics of forest exploitation enterprises. A questionnaire was used to collect these data and also information of current quality standards for saw and plywood logs.

### 3.5.2 *Felling and winching efficiency studies*

Two studies were done on methods of controlled felling and two on winch skidding to investigate the efficiency of these methods. One felling study investigated the relationship between dbh of a felled tree and actual felling time of approximately 200 trees of dbh ranging from 35 to 100 cm and of wood densities (specific weight) ranging from 0.66 to 1.05 g/cm<sup>3</sup> (see Section 6.1.4). In the other study focusing on directional felling, time was recorded in the same way but was related to dbh and also to the natural lean of the tree. The feasibility of directional felling was examined in terms of conditions for efficient skidding of felled trees, taking into account safety aspects of the method (see Section 6.1.3).

The time and method studies on winching were designed to obtain more insight into this technique, its production factors and variables. Winching time was examined in relation to winching distance, log dimension, and dimension of the



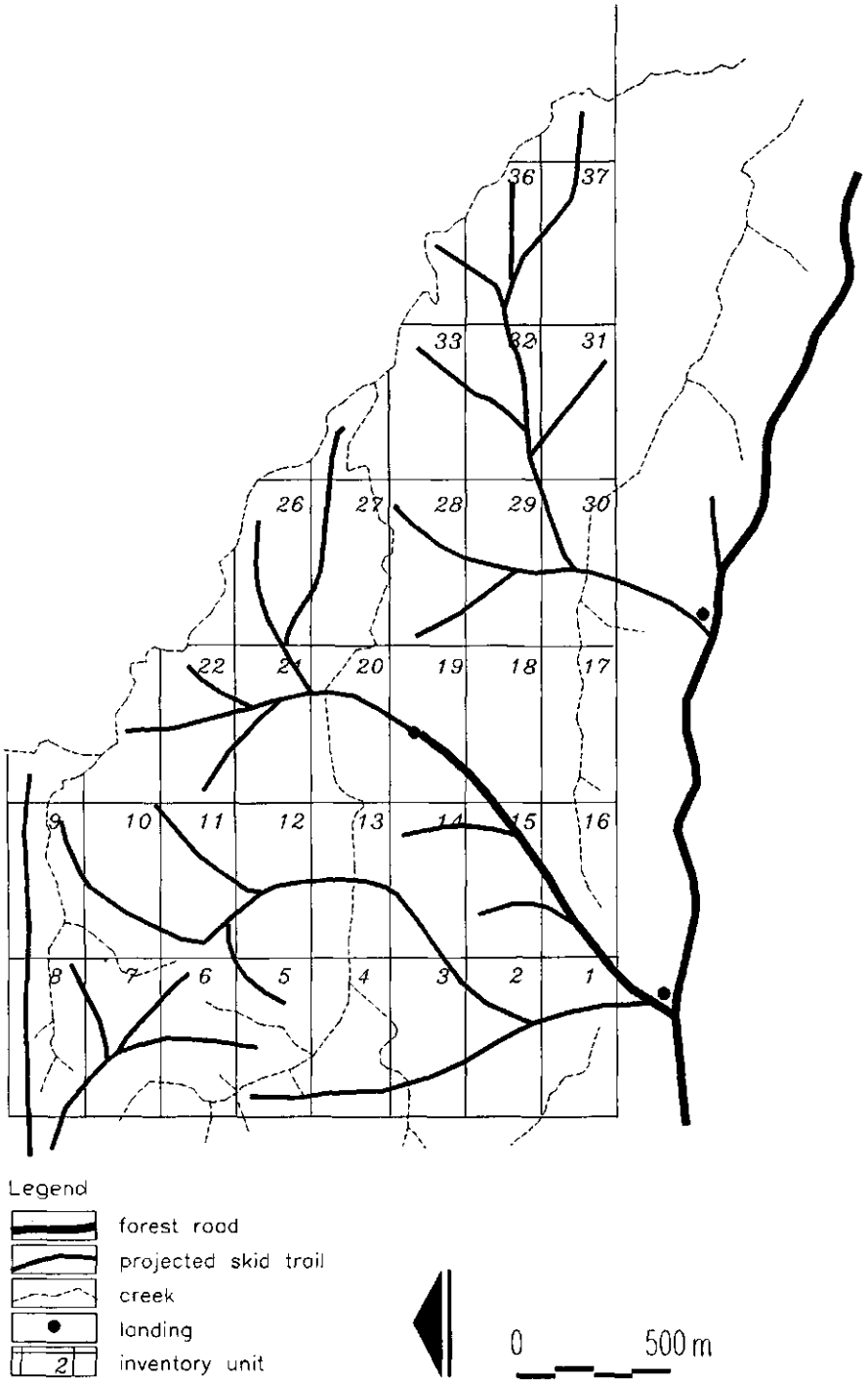


Fig. 3.11 Patamacca research area: logging compartment with inventory grid (Source: van Leersum, 1984b)

winch line. In the first experiment logs were winched in full length with a line of 30 m length and 19 mm diameter by a Caterpillar skidder as specified in Table 3.2. In the second experiment the same type of skidder was used with the winch line 70 m long, 16 mm diameter and flexible in structure to winch logs in full length and in lengths of 7 to 10 m (see Section 6.3).

### *3.5.3 Efficiency of BSH logging*

The logging method of the Bruynzeel Suriname Wood Company (BSH) was studied as an example of semi-controlled logging (see Section 3.1.5).

The skid trail network was examined in eight prospecting units in one of the BSH harvesting compartments representing a forest area of 100 ha of the Tibiti landscape type (Fig. 3.11). All trails used by crawlers and skidders were identified, measured and mapped. Skidding gaps, that is the area cleared or rutted by crawler tractors in presorting operations, were mapped separately. Travelling intensity of machines was assessed for the main and branch trails and the felling intensity derived from prospecting maps and felling forms.

The BSH accounting and management system was examined. This study included an analysis of logging data of the period 1978 - 1986. The results of these studies are discussed in Sections 6.1 and 6.4.

## 4 Logging impacts to stand and harvested wood

Using the model of logging impacts on the forest ecosystem and forest soil in Section 1.3, data collected on damage to stand and harvested product were analysed. The impact of the first selective harvest ten years prior to the study is discussed in Section 4.1. This investigation was based on the LBB forest inventory of 1953-1954 and surveys and prospectings done for this study in 1981. The actual commercial timber stock was calculated, the harvestable volume and logging effects of the first harvest were assessed. Harvesting experiments from the period January 1982 to July 1984 are discussed in Sections 4.2-4.4. Controlled and conventional logging were compared for felling and skidding damage and wood damage.

### 4.1 Impact of the first selective harvest

Much of the Forestry Belt has been harvested since the start of the road building programme in the 1950s (Section 2.5). However, little is known about the impact on the quality of the remaining stand, as no attention was given to this aspect of forest management at that time. Post-harvesting surveys were carried out to see that logging stipulations were met, not to assess stand damage.

These surveys have shown that not all commercial trees were harvested. Approximately 25% of the marketable trees were overlooked in the forest (Fraser, 1973; ILACO, 1977; Noelmans, 1979). Until 1974 the accepted idea of forest regeneration was that logged-over concessions could yield a second harvest of commercial trees and potential timber species as market demand was expected to change in favour of lesser known species.

Two issues in considering the quality of logged-over stands in the Forestry Belt are the number of remaining commercial trees and the degree of harvesting damage in terms of elastic and plastic strain. These interrelated issues are of importance in judging whether a second harvest is economically viable and ecologically acceptable. In the present study this was examined in three successive steps:

- an appraisal has been made to reconstruct the original forest composition of the research area (Section 4.1.1);

- the stand damage was assessed in terms of affected forest area (Section 4.1.3);
- the remaining harvestable stock was calculated and related to the economic value of the forest (Section 4.1.4).

#### 4.1.1 Composition of the original commercial stand

Until 1970 inventories and management plans were based on a limited number of commercial species. This was in accordance with prevailing harvesting practices when only six species accounted for 80% of the market. The commercial species list of the Forest Service (Japing and Japing, 1960; Vink, 1965) is somewhat confusing in this context, as the number of these species has increased since the list was prepared (see Appendixes III and VII). In the following discussion only the group of original commercial species is considered and other species are referred to as non-commercial species.

Forest data were derived from the Forest Service inventory reports and management plans (see Section 3.3.4). As these were actual harvesting plans, species densities were directly calculated as gross volume of standing timber ( $\text{m}^3/\text{ha}$ ) and listed in felling schemes. This presentation, which is the result of a 2% systematic inventory, is sufficient to describe the overall characteristics of the forest in the research area before the first timber harvesting.

The density ( $\text{m}^3/\text{ha}$ ) of 15 commercial species in Mapane region is listed in Table 4.1 for three inventory blocks, known as Mapane VI (Concession 1), Mapane IX (Concession 2) and Mapane XIV (Concession 3), the latter two being in the research area and the former, which is 21 km north, was included for comparison. Marsh forest, which has smaller trees in both height and girth because of soil conditions (see Section 3.2.2), is not included in the present study. The difference in stocking between mesophytic tropical rain forest and marsh forest is typical for the Mapane region.

The inventory data were compared with data from the ecological study of Schulz (1960) and evaluation survey reports of Bubberman (1980). According to Schulz (1960), a leading species in the rain forest is characterized by comparatively high density (number of individuals per ha) and by distributional frequency (percentage of 10 m x 10 m plots with one or more individuals of a species). Schulz composed a list of abundant species representative of the Mapane forest. In this context, a leading species had at least one big tree (dbh > 35 cm) per ha and a frequency of at least 1%. Seven of the 15 commercial species listed in Table 4.1 appear on Schulz' list as leading species. These are basralokus (*Dicorynia guianensis*), gronfoeloe (*Qualea spp.*), kopi (*Goupia glabra*), krapa (*Carapa procera*), pisi (*Ocotea* and *Nectandra spp.*), rode sali (*Tetragastris altissima*) and wana (*Ocotea rubra*) (see also Appendix III).

Poorly represented species, but still of commercial interest are: pakoeli (*Platonia insignis*), purperhart (*Peltogyne paniculata* and *P. venosa*) and kromanti kopi

TABLE 4.1. Mapane forest: stocking of 15 commercial species in three inventory blocks\* in pristine forest

| Species                    | Gross volume (m <sup>3</sup> /ha) of standing commercial trees with dbh > 35 cm |       |       |                                 |       |       |
|----------------------------|---|-------|-------|---------------------------------|-------|-------|
|                            | High forest in concession (no)  |       |       | Marsh forest in concession (no) |       |       |
|                            | 1   | 2     | 3     | 1                               | 2     | 3     |
| Commercial species         |   |       |       |                                 |       |       |
| baboen                     | 0.1   | 1.9   | 1.3   | 7.9                             | 3.8   | 3.5   |
| basralokus                 | 10.7  | 7.3   | 12.1  | 2.0                             | 0.5   | 1.4   |
| bruinhart                  | 1.1   | 8.8   | 2.0   | 0.3                             | 1.6   | 0.6   |
| groenhart                  | 2.3   | 3.8   | 0.8   | 0.8                             | 1.3   | 0.1   |
| gronfoeloe                 | 5.8   | 4.1   | 4.7   | 0.0                             | 0.4   | 3.3   |
| kabbes                     | 1.3   | 3.7   | 3.4   | 1.5                             | 0.5   | 0.9   |
| kopi                       | 7.0   | 6.5   | 5.6   | 1.2                             | 3.2   | 1.0   |
| kromanti kopi              | 0.2   | 0.3   | 0.7   | 1.1                             | 0.0   | 0.0   |
| krapa                      | 3.4   | 3.1   | 2.4   | 4.7                             | 3.2   | 4.2   |
| pakoeli                    | 0.0   | 0.3   | 0.1   | 0.0                             | 0.0   | 0.0   |
| pisi                       | 3.0   | 5.5   | 3.2   | 0.2                             | 0.8   | 0.4   |
| purperhart                 | 0.2   | 0.0   | 0.1   | 0.0                             | 0.2   | 0.0   |
| rode sali                  | 6.9   | 8.3   | 3.9   | 1.8                             | 2.9   | 2.2   |
| soemaroeba                 | 1.8   | 2.0   | 1.1   | 0.0                             | 1.3   | 2.6   |
| wana                       | 5.0   | 3.5   | 4.7   | 0.0                             | 0.0   | 0.2   |
| All commercial species     | 48.8  | 59.1  | 46.1  | 21.5                            | 19.7  | 20.4  |
| All non-commercial species | 151.3   | 156.1 | 131.3 | 95.7                            | 86.4  | 83.5  |
| All species                | 200.1   | 215.2 | 177.4 | 117.2                           | 106.1 | 103.9 |

Source: LBB forest inventory (1953-1954)

\* Inventory blocks: Mapane VI (Concession 1; 2400 ha), Mapane IX (Concession 2; 3660 ha) and Mapane XIV (Concession 3; 1600 ha)

(*Aspidosperma spp.*). This is in accordance with the distribution patterns of Schulz. The relatively high volume (8.8 m<sup>3</sup>/ha) of bruinhart (*Vouacapoua americana*) in Concession 2 is also a typical feature of the Mapane forest (Schulz, 1960). Although not classified as a leading species, bruinhart may show a strong tendency to gregariousness in limited areas (see Table IV.4, Appendix IV). Concentrations of bruinhart trees and young regeneration on small sites are not unusual in the Mapane forest. Soil factors seem to play a significant role in this respect (Schulz, 1960).

Another conspicuous species is baboen (*Virola spp.*). In fact, two species were grouped in the inventory tables: hoogland baboen (*Virola melinonii*) and laagland baboen (*Virola surinamensis*). Hoogland baboen is generally found in high forest

in low densities, while laagland baboen may 'lead' in marsh forest and 'dominate' in freshwater swamp forest (see Appendix II). Stocking of these species is relatively high in Concessions 2 and 3 with approximately 1 to 2 trees per ha (dbh > 35 cm).

The composition of commercial species in the research area is similar to the descriptions given by Schulz (1960) and Rollet (1974) for the Mapane region. This is in spite of the variation in forest composition from site to site and even from hectare to hectare as shown by inventories. On basis of these similarities, the research area may be considered to be representative of Mapane forest.

The forest potential of valuable timber species such as basralokus (*Dicorynia guianensis*), bruinhart (*Vouacapoua americana*), kopi (*Goupia glabra*), pisi (in particular *Nectandra grandis*) and wana (*Ocotea rubra*) is evident from Table 4.1. These five timbers comprise 55% of the gross volume of the 15 listed species.

The weighted mean stock of all commercial trees (dbh > 35 cm) was assessed to be 53.2 m<sup>3</sup>/ha gross volume, that is approximately 27% of the total stock of all tree species. In spite of the limited number of 15 commercial species out of a total of more than 100 species, about 25% of the stock - by volume - is of commercial interest indicating that commercial trees dominate the upper storeys. On basis of an average log bole of 2.2 m<sup>3</sup>, as used by LBB for reconnaissance surveys, it is roughly estimated that 20-25 trees could have been harvested per hectare. However, this logging intensity has never been achieved in Suriname. Until 1970 timber harvesting was restricted to 4-8 trees per hectare (LBB Statistics) while presently the maximum level is about 10-13 trees/ha (BSH, 1979-1986).

Although the inventory data were collected in a 2% systematic enumeration, it seems reasonable to assume that the forest was similar to that in other parts of Mapane (see also ILACO, 1977; INFORSON, 1979). On the basis of the figures presented in Table 4.1, it was assumed that the three concessions received a similar logging treatment during the first selective harvest, which (see Section 4.1.2) was probably a creaming off of the forest. These findings justify the choice of the research area in the Mapane forest.

The final part of the characterization of the pristine forest as a source of timber is a breakdown of stem volumes into 10 cm diameter classes. The size-class distribution or 'total structure' (Rollet, 1978) is a significant factor in harvesting planning as it gives information on dimensions of harvestable trees.

The computed size-class distribution listed in Table 4.2 is a summary of a 25 ha inventory sample in which all commercial trees above 25 cm dbh were measured (LBB Statistics). This diameter distribution is in accordance with other surveys (see ILACO, 1977) and also with tree morphology of commercial trees described by Lindeman and Mennega (1963) and by Schulz (1960). Most of the commercial species can reach great dimensions, as shown by their volume distribution over the higher size classes. This is evident for basralokus, groenhart, kopi and pisi. A few species (bruinhart, krapa and rode sali), however, have a significant lower maximum diameter, which is demonstrated by their relatively high yield in class 35-45 cm dbh (see Jonkers, 1987). Others, like baboen, are average in size, while wana ranks among the largest trees.

TABLE 4.2. Mapane forest: computed diameter class distribution of 15 commercial species in pristine forest

| Species       | Frequencies (m <sup>3</sup> /ha) per diameter class (cm dbh) |       |       |       |       |       |       |     | Total |
|---------------|--|-------|-------|-------|-------|-------|-------|-----|-------|
|               | 25-35  | 35-45 | 45-55 | 55-65 | 65-75 | 75-85 | 85-95 | >95 |       |
| Baboen        | 0.8  | 1.3   | 0.7   | 0.7   | 0.5   | 0.0   | 0.5   | 0.0 | 4.5   |
| Basralokus    | 0.6  | 0.9   | 1.6   | 2.0   | 1.4   | 1.2   | 1.2   | 0.4 | 9.3   |
| Bruinhart     | 0.5  | 2.3   | 1.7   | 0.7   | 0.7   | 0.7   | 0.6   | 0.0 | 7.2   |
| Groenhart     | 0.1  | 0.1   | 0.5   | 1.0   | 0.7   | 0.3   | 0.1   | 0.1 | 2.9   |
| Gronfoeloe    | 0.4  | 0.8   | 0.5   | 0.7   | 0.2   | 0.8   | 0.7   | 0.6 | 4.7   |
| Kabbes        | 0.1  | 0.3   | 0.6   | 0.8   | 0.6   | 0.5   | 0.4   | 0.4 | 3.7   |
| Kopi          | 0.1  | 0.4   | 1.0   | 0.8   | 1.3   | 1.0   | 0.9   | 0.8 | 6.3   |
| Kromanti kopi | 0.0  | 0.0   | 0.1   | 0.1   | 0.0   | 0.0   | 0.0   | 0.0 | 0.2   |
| Krapa         | 1.4  | 2.0   | 1.1   | 0.3   | 0.1   | 0.0   | 0.0   | 0.0 | 4.9   |
| Pakoeli       | 0.0  | 0.0   | 0.0   | 0.1   | 0.1   | 0.0   | 0.0   | 0.0 | 0.2   |
| Pisi          | 1.0  | 1.0   | 1.3   | 1.0   | 0.5   | 0.5   | 0.3   | 0.2 | 5.8   |
| Purperhart    | 0.0  | 0.0   | 0.0   | 0.0   | 0.0   | 0.1   | 0.0   | 0.0 | 0.1   |
| Rode sali     | 2.2  | 2.0   | 2.2   | 1.8   | 0.7   | 0.3   | 0.0   | 0.0 | 9.2   |
| Soemaroeba    | 0.1  | 0.1   | 0.3   | 0.4   | 0.4   | 0.3   | 0.2   | 0.1 | 1.9   |
| Wana          | 0.1  | 0.1   | 0.4   | 0.8   | 0.4   | 0.6   | 0.5   | 1.0 | 3.9   |
| Total         | 7.4  | 11.3  | 12.0  | 11.2  | 7.6   | 6.3   | 5.4   | 3.6 | 64.8  |

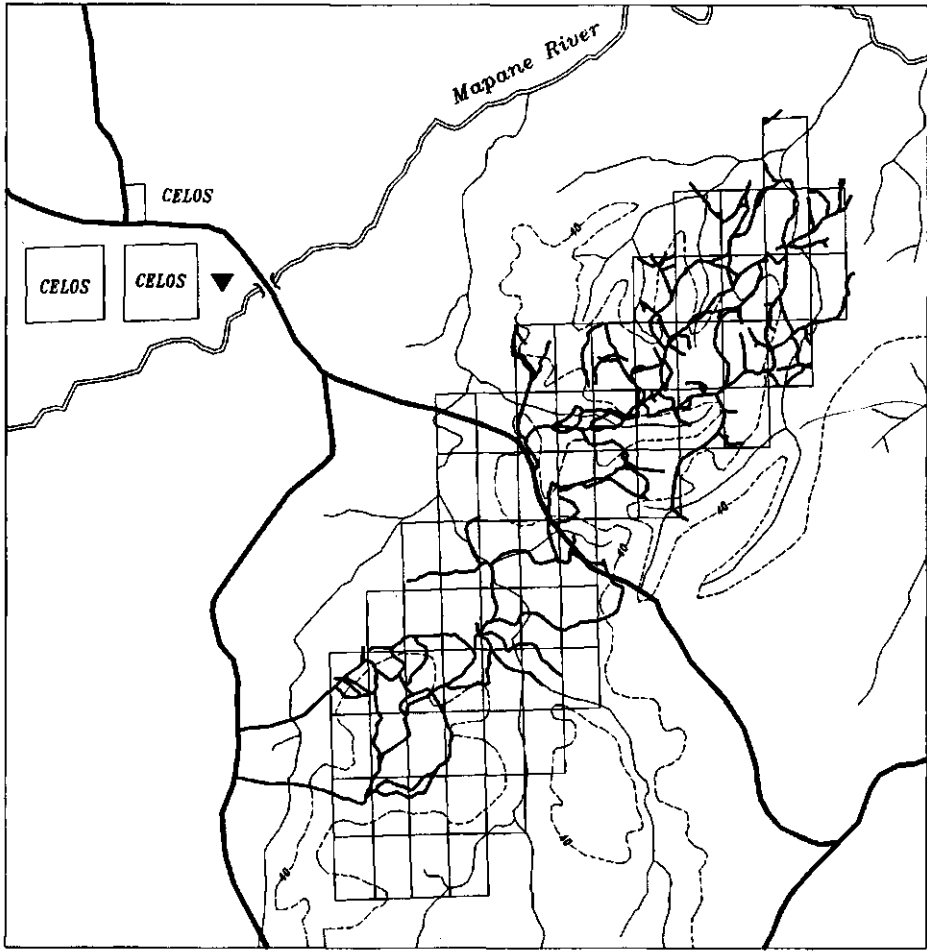
Source: LBB Forest Research Division (1960)

#### 4.1.2 Assessment of felling intensity




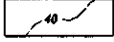

After mapping the trail system, a stump enumeration was carried out to assess felling intensity (see Section 3.3.4). While old skid trails were relatively easy to identify, the stumps were difficult to find. Many had decomposed completely and could only be located by careful inspection of the forest floor.

The stump enumeration helped to reconstruct the pattern of the first harvest. Although it was not possible to determine the exact location of all stumps, felling intensity could be assessed satisfactorily from a combination of felling and skidding effects. The highest felling intensity was assessed to be 8 trees per ha; this was reconstructed for the inventory units 21, 22, and 23 (see Fig. 3.3). A felling intensity of 4-6 trees per ha was found in 40% of the inventory units. About 30% of the inventory units were very lightly felled and 30% remained untouched. This confirmed the initial impression of light exploitation and of a logging intensity which varied greatly from site to site.

The effects of felling damage could not be assessed accurately. Old felling gaps were identified as interruptions in the forest cover mostly filled with secondary vegetation and fast growing trees, but could not always be distinguished from natural chablis. The total area of gaps (natural and man-made) assessed from the



Legend

-  creek
-  skid trail
-  forest road
-  contour line, 40 m above sea level
-  Akinto Soela

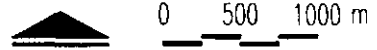


Fig. 4.1 Mapane research area: actual skid trail pattern resulting from the first selective harvest in the 1960s



ground survey and aerial photographs (see Fig. 4.4) was less than 6%. This was based on an average gap area of 117.9m<sup>2</sup> computed in the present study (see Section 4.2.1). The first selective harvest has had a light felling impact on the forest.

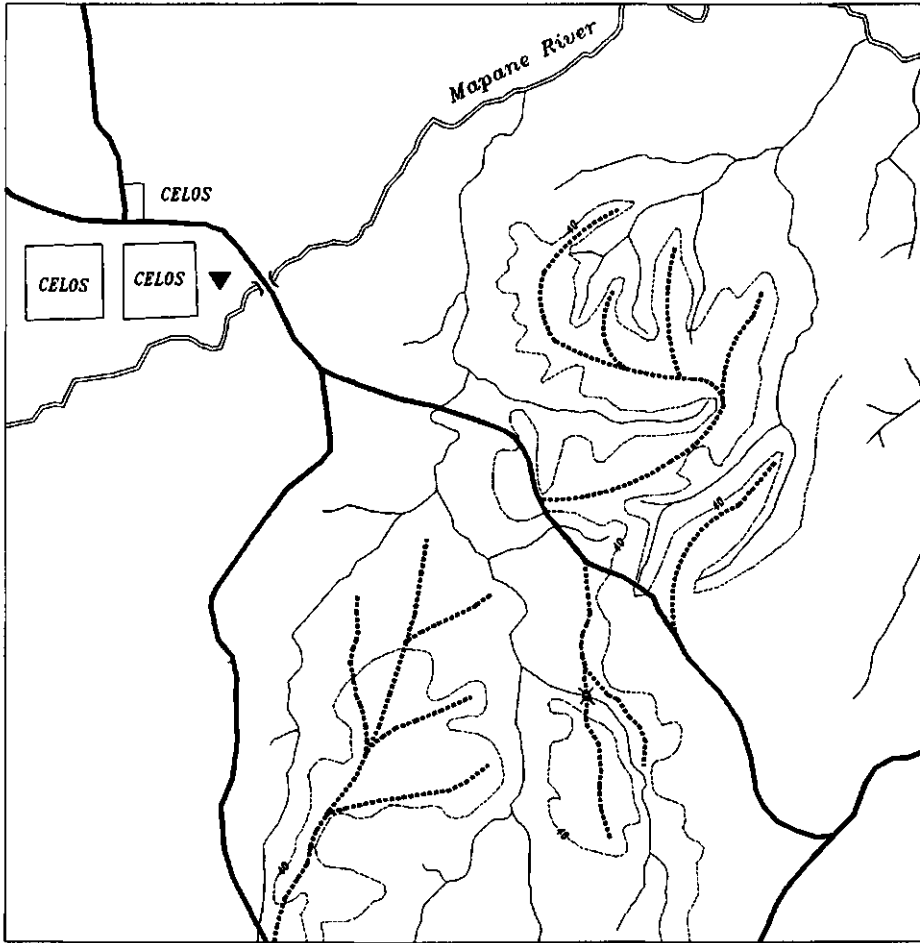
#### *4.1.3 Assessment of skidding damage*

One of the results of the topographic survey (see Section 3.3.4) is a terrain map, showing the skid trail network used in timber harvesting (Fig. 4.1). Although most trails were covered with herbs and young trees, the vegetation was very different from the surrounding forest. Traces of disturbed soil were often visible as ruts or sometimes as bare paths in the forest. This map serves as a basis for discussion of logging methods in relation to impact on the forest stand. Four features of the skid trail system are of importance in this respect: location, pattern, density and creek crossings.

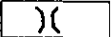
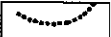


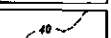

*Location.* The actual skid trail network is shown in Figure 4.1, and the designed network included in a management plan drafted by the Forest Service to control logging operations in Concession 2 and 3 in the research area (LBB, 1961) is given in Figure 4.2. Comparison shows that harvesting operations have not been carried out by the concessionaires according to the management plans. The networks are completely different. Concession 2 was designed to be logged through five main skid trails, carefully projected along the water divides. For the same purpose, seven main trails were projected in Concession 3. However, in both concessions trails were formed irrespective of terrain slopes, water courses and swampy sites. In the southern part, the main direction of log transport was even the opposite to the design. Most logs were transported to the east instead of the west branch road.

*Pattern.* The pattern of the actual trail network is characterized by (see Fig. 4.3) winding trails and trails running parallel over distances of 20 to 30 m with many crosslinks (short cuts) between trails. Trails are not always connected to the truck road in the shortest, most direct way. Hence, many more trails have been constructed than needed for log collection and transport. No distinction has been made between primary and secondary trails and consequently there is no specific network orientation.

*Trail density.* Given an average area of 5-8% for efficient trail systems (see Section 4.3), a great variation in trail density was observed in various sections of the research area. A relatively high density (11-16%) was found in the north and in the centre of the southern section, and a low to moderate density (4-6%) in most of the southern section.



Legend

-  culvert
-  skid trail (projected)
-  creek
-  truck road
-  contour line, 40 m above sea level
-  Akinto Soela

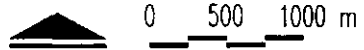
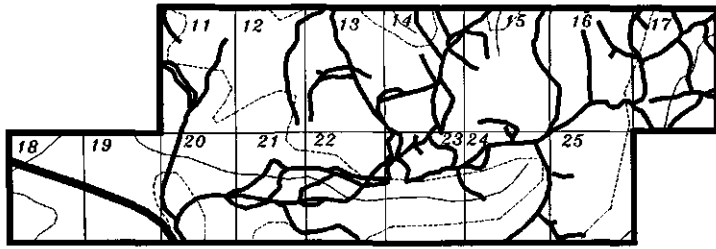


Fig. 4.2 Mapane research area: skid trail design according the 1960 management plan (Source: LBB, 1961)



Legend






-  12 number inventory unit
-  creek
-  skid trail
-  truck road
-  contour line, 40 m above sea level



Fig. 4.3 Mapane research area: a detail of the skid trail network resulting from the first selective harvest in the 1960s

*Creek crossings.* A trail system should be designed to avoid creek crossings wherever possible or if unavoidable, to bridge them with provisional culverts. No less than six creek crossings were found in the south and more than twelve in the north of the area, yet the original plan projected only two culverts in the southern concession.

**4.1.4 Quality of the remaining stand**

Prospecting data from the preharvesting survey of the research area (Section 3.3.4) were used to calculate the remaining stock of commercial and potential species (Table 4.3; Tables IV.1-IV.3, Appendix IV). Comparison with inventory data of 1953-1954 (Table 4.1) indicate that approximately 50% of commercial stock had been felled in the first harvest. This is not in accordance with findings of the preliminary survey of a light exploitation (Section 4.1.2). Extremely low harvests of 2.5 m<sup>3</sup>/ha for Concession 2 (Rama area) and 6.1 m<sup>3</sup>/ha for Concession 3 (Tibiti area) were calculated from the logging registers of the Forest Service (see Table 4.4) with an assumed log bole of 2.2 m<sup>3</sup>. There are a number of explanations for this discrepancy.

The original commercial timber stock of the research area had never been assessed accurately. The general inventory of 1953-1954 was based on a 2% systematic sampling of the entire management zone of 69 000 ha and is, therefore,

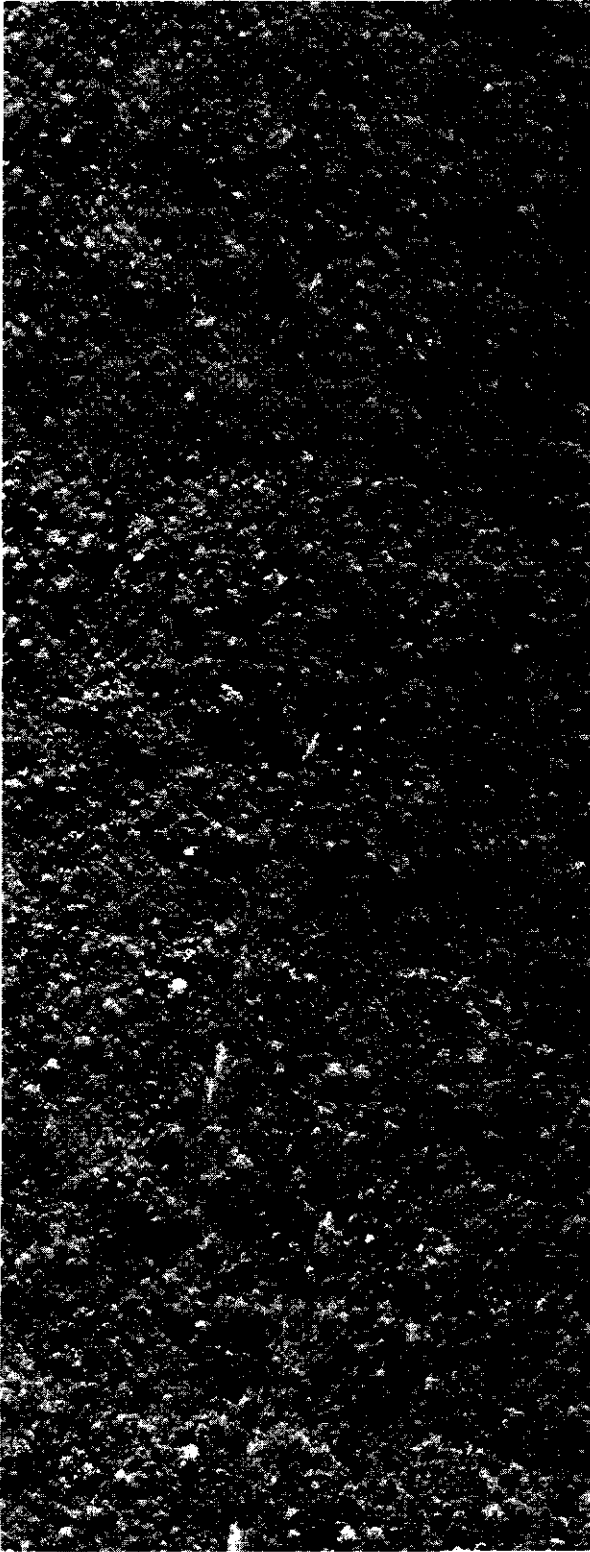


Fig. 4.4 Mapane research area: aerial stereophotograph of the central part of the research area, ten years after the first selective harvest. Scale 1:10 000. Courtesy of Centraal Bureau Luchtkartering, Paramaribo.

TABLE 4.3. Mapane research area: stocking of commercial and potential species in lightly harvested forest in 1982

| Species                               | Gross volume (m <sup>3</sup> /ha) of standing trees of >35 cm dbh |                               |
|---------------------------------------|---|-------------------------------|
|                                       | Concession 2<br>(Rama area)                                       | Concession 3<br>(Tibiti area) |
| <b>Commercial species</b>             |   |                               |
| baboen                                | 0.6   | 1.9                           |
| basralokus                            | 2.8   | 1.7                           |
| bruinhart                             | 7.8   | 1.0                           |
| groenhart                             | 0.2   | 1.2                           |
| gronfoeloe                            | 1.5   | 1.6                           |
| kopi                                  | 1.8   | 1.7                           |
| krapa                                 | 1.5   | 2.7                           |
| kromanti kopi                         | 0.1   | 0.0                           |
| pakoeli                               | 0.0   | 0.0                           |
| pisi                                  | 1.3   | 0.0                           |
| purperhart                            | 0.1   | 0.3                           |
| rode kabbes                           | 0.3   | 0.5                           |
| rode sali                             | 4.8   | 7.3                           |
| soemaroeba                            | 0.3   | 2.9                           |
| wana                                  | 0.5   | 0.2                           |
| zwarte kabbes                         | 0.1   | 0.0                           |
| <b>All commercial species</b>         | <b>23.7</b>   | <b>23.0</b>                   |
| <b>Potential species</b>              |   |                               |
| agrobigi                              | 0.7   | 0.6                           |
| goebaja                               | 0.5   | 0.7                           |
| goebaja kwari                         | 0.3   | 0.6                           |
| kwari                                 | 0.6   | 1.1                           |
| kwatapatoe                            | 0.7   | 0.2                           |
| okerhout                              | 1.4   | 1.9                           |
| tingimoni                             | 2.1   | 0.4                           |
| tingimonisali                         | 1.0   | 0.5                           |
| others                                | 4.4   | 3.9                           |
| <b>All potential species</b>          | <b>11.7</b>   | <b>9.9</b>                    |
| <b>Commercial + potential species</b> | <b>35.4</b>   | <b>32.9</b>                   |

not comparable with the 100% prospecting of 1981/1982. The inventory methods differ greatly with regard to sampling techniques, quality assessment of harvestable trees and data processing. The 1953-1954 inventory was found to be inaccurate in the assessment of usable trunk volumes as listed in Table 4.1 (de Milde and Inglis, 1974a). The Forest Service used to recommend a correction factor of 35% to reduce the estimated yields published in the management plans. The prospecting

TABLE 4.4. Mapane research area: previous selective timber harvests

| Year  | Number of registered logs transported from the research area |                                    |
|-------|--|------------------------------------|
|       | Concession 2 (Rama)<br>(3660 ha)                             | Concession 3 (Tibiti)<br>(1600 ha) |
| 1969  | 0  | 405                                |
| 1970  | 0  | 1010                               |
| 1971  | 476  | 164                                |
| 1972  | 307  | 999                                |
| 1973  | 2117   | 983                                |
| 1974  | 0  | 0                                  |
| 1975  | 352  | 429                                |
| 1976  | 0  | 0                                  |
| 1977  | 0  | 1790                               |
| 1978  | 644  | 965                                |
| 1979  | 82   | 1304                               |
| 1980  | 0  | 1067                               |
| 1981  | 0  | 0                                  |
| 1982  | 130  | 15                                 |
| Total | 4108   | 9131                               |

Source: LBB Forest Inspection Division (1984)

method of the present harvesting study included an accurate quality assessment of enumerated trees, but excluded trees rejected for felling (see Section 3.3.4). Consequently, prospecting data are more reliable than inventory data.

In spite of the low logging intensity, the loss of major commercial trees is appreciable in the research area. Species such as kopi, basralokus, wana and pisi, were creamed from the forest in quantities of at least 6 m<sup>3</sup>/ha. Figures given in the logging registers (Table 4.4) are considered to be low estimates, because only transported logs were recorded by the Forest Inspection Division for calculation of retribution fees. Felled trees left in the forest as rejects or as a result of improper logging were not recorded.

Although the remaining forest was poorer in commercial timber than the pristine forest of 30 years earlier (Tables 4.1 and 4.3), a second harvest of quality timber was considered to be economically viable. Harvestable stock of commercial and potential species was assessed to be 35.4 m<sup>3</sup>/ha for the Rama and 32.9 m<sup>3</sup>/ha for the Tibiti area. Approximately 65% of this stock consisted of commercial timber. The area was relatively rich in bruinhart (*Vouacapoua americana*) and rode sali (*Tetragastris altissima*) (see Tables IV.4 and IV.3, Appendix IV).

## 4.2 Felling impacts of the second harvest

Measurement of felling gaps was found to be a quick and efficient method to assess felling damage. A complete (100%) enumeration of such gaps was carried out in all eight experimental compartments, following standard procedure described in Section 3.3.5. For each compartment, the total gap area was calculated as the sum of individual gaps and expressed as a percentage of the compartment area. The gap area was the first parameter used to compare felling damage in the eight experimental compartments (see Table 4.5).

Two extremes are obvious. In compartment 1,2 (conventional logging) felling gaps covered 16.5%, while in compartment 3,2 (controlled logging) the gap area was only 6.0%. In addition, the average gap size in these two compartments was 275.8 m<sup>2</sup> and 130.7 m<sup>2</sup> respectively. There was little difference between the six compartments under controlled logging, and felling damage was substantially less than in conventionally logged compartments. Although it may be concluded that conventional felling is more damaging than controlled felling because of the larger felling gaps, further testing is required since a number of factors and parameters are involved in the gap-forming process, namely:

- diameter of the felled tree (see Section 4.2.1);
- logging method (see Section 4.2.2);
- logging intensity (see Section 4.2.4);

TABLE 4.5. Felling damage: gap area, logging method, and mean tree diameter in the experimental compartments

| Logging method        | Treatment code | Area (ha) | Number of gaps | Gap area (%) | Mean gap area (m <sup>2</sup> ) | dbh* (cm) |
|-----------------------|----------------|-----------|----------------|--------------|---------------------------------|-----------|
| Conventional logging  | 1,1            | 20        | 103            | 11.4         | 221.1                           | 63.2      |
|                       | 1,2            | 20        | 121            | 16.5         | 275.8                           | 61.6      |
| Controlled logging**  | 2,1            | 10        | 65             | 7.3          | 112.2                           | 58.8      |
|                       | 2,2            | 10        | 57             | 7.4          | 129.4                           | 59.2      |
| Controlled logging    | 3,1            | 10        | 73             | 6.8          | 98.3                            | 53.1      |
|                       | 3,2            | 10        | 74             | 6.0          | 130.7                           | 52.7      |
| Controlled logging*** | 4,1            | 20        | 93             | 7.1          | 127.7                           | 64.4      |
|                       | 4,2            | 10        | 34             | 6.5          | 153.4                           | 59.9      |

\* Mean diameter of felled trees in an experimental compartment

\*\* With directional felling

\*\*\* With winching

- number of trees surviving felling (see Section 4.2.3);
- forest composition (see Section 4.2.4).

#### 4.2.1 Diagnostic significance of tree diameter

The size of a felling gap is largely determined by the crown of the felled tree. An extended and bulky crown will cause more damage than a relatively small one. Difficult to measure, crown size is an inaccurate parameter. Even when crown projection on the forest floor is considered to be an acceptable parameter for its dimensions, the measuring procedure is inaccurate and time consuming.

Tree diameter is easy to measure and is also related to the size of a tree, although the correlation between diameter and crown size is not very strong (Mellink, 1981; Jonkers, 1987). Diameter of felled trees was derived from prospecting forms. For each of the mapped felling gaps, the dbh of the felled tree was known. The relationship between these paired data termed Y (gap area) and X (dbh) was investigated for each experimental compartment. The relationship was tested in a linear regression analysis (LRA) and expressed as:

$$\ln Y = C + bX \quad (4.1)$$

where:

Y = gap area (m<sup>2</sup>)

X = dbh of the felled tree (cm)

b = regression coefficient

C = constant

A computer programme was used for the linear regression analysis. The results are summarized in Table IV.5 (Appendix IV). For a discussion of the LRA, reference is made to current statistical handbooks (for example, Snedecor and Cochran, 1980; Ott, 1984). Eight equations were obtained from the test, representing the relationship between the natural logarithm of Y (ln Y) and X in an experimental compartment:

$$\ln Y_{1,1} = 4.21 + 0.015 X \quad (4.2)$$

$$\ln Y_{1,2} = 4.64 + 0.013 X \quad (4.3)$$

$$\ln Y_{2,1} = 3.47 + 0.018 X \quad (4.4)$$

$$\ln Y_{2,2} = 3.76 + 0.017 X \quad (4.5)$$

$$\ln Y_{3,1} = 3.75 + 0.013 X \quad (4.6)$$

$$\ln Y_{3,2} = 3.77 + 0.018 X \quad (4.7)$$

$$\ln Y_{4,1} = 3.06 + 0.024 X \quad (4.8)$$

$$\ln Y_{4,2} = 3.63 + 0.020 X \quad (4.9)$$

where: indices indicate experimental compartment.



The effect of the diameter of felled trees on gap area was examined. A coefficient of variation of 65% and a correlation coefficient of 0.46 ( $r^2 = 0.21$ ) were computed for all 620 observations (Table IV.5, Appendix IV). For the single equations  $r$  varies from 0.36 to 0.62. This means that only 21% of the sum of squares of deviation of  $Y$  can be explained by the linear relationship of  $Y$  with  $X$ . There is evidence that the diameter of the felled trees played a significant role in the gap-forming process, but its influence was probably less than that of other factors.

Graphs from the eight equations given in Figure 4.5 indicate a higher level of felling damage in the conventionally felled units (1,1 and 1,2) but give no indication of a difference between the three types of controlled felling. This finding was tested statistically as follows.

The regression coefficient  $b$  is the slope of the fitted line. A significant difference in  $b$ -values may denote a significant difference in treatment effects. This was verified by an analysis of variance (ANOVA) carried out at a significance level of 0.05 (Table IV.6, Appendix IV). No significant difference was found between the

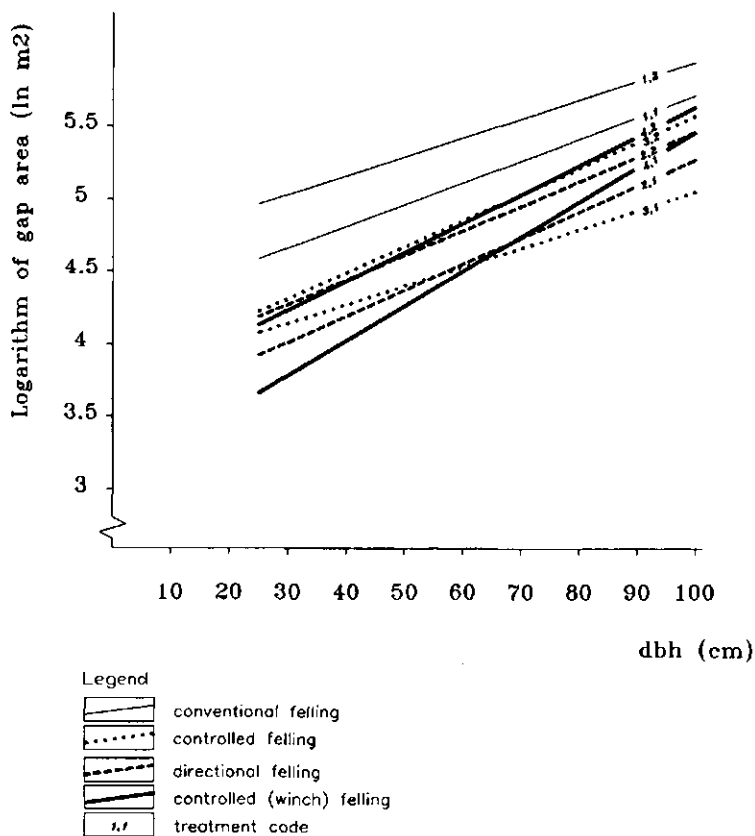


Fig. 4.5 Felling impact: relationship between diameter of felled tree and gap area

b-values ( $F(3,4) = 4.20$ ). Apparently, treatment effects were similar in the eight experimental compartments.

Comparison of the test results with the fitted lines in Figure 4.5 indicates:

- Fitted lines run approximately parallel, suggesting a similar effect of the diameter of felled trees on gap area by the various logging treatment.
- The difference in height between two paired lines (duplicates) denotes a difference between paired experimental compartments. This difference refers partly to variability of forest composition and partly to impacts of other factors.
- The paired lines of the conventional logging compartments (1,1 and 1,2) are clearly higher than lines of all controlled compartments. This might be explained as a higher level of felling damage (total gap area) in uncontrolled compartments. This treatment effect is examined in the following section.

#### *4.2.2 Effect of felling methods on gap size*

A major question in the felling study was whether controlled felling can influence the size of a gap. In other words, is it possible to organize felling so that excessively large gaps can be avoided or restricted.

Another ANOVA test was required to determine the impact of logging treatments on gap area. In this test, the tree diameter (X) was not considered as a diagnostic variable. The median of Y-values (gap areas) was computed for each experimental unit and tested in an ANOVA programme (see Table IV.7, Appendix IV). No difference was found at the significance level of 0.05. As this test was not conclusive, further testing was needed to determine the impact of controlled felling.

As controlled felling was expected to reduce felling damage significantly, the difference in treatments was tested with the Student-test. The null-hypothesis that there is no difference between uncontrolled (treatment 1) and controlled felling (treatments 2, 3 and 4 combined) was tested against the (alternative) hypothesis that uncontrolled felling is more damaging than controlled felling. In this analysis the differences between controlled felling with or without directional felling and winching were ignored. The null-hypothesis (no difference) was rejected in favour of the alternative hypothesis (difference) at a significance level of 0.05 ( $t = 2.17$ ,  $df = 4$ ). Hence the conclusion is justified that controlled felling had helped to restrict the gap area.

#### *4.2.3 Number of damaged trees in felling gaps*

Felling damage is restricted to gaps where most trees are completely destroyed and to the immediate surroundings where many trees are injured. In 5% of the mapped

gaps (including the surrounding area) all trees above 20 cm dbh were measured and examined for injury (see Section 3.3.5). In some gaps, recording was extended to small trees (> 5 cm dbh). The data are presented in Table 4.6 together with data of a complete assessment of injured trees in a CELOS experiment in the Kabo area conducted by Jonkers (1987).

Small trees are more vulnerable to destruction and severe injury than larger individuals, and play an important role in the regeneration of the harvested stand. Approximately 80% survived felling without damage. Less than 11% of trees above 35 cm dbh were irreversibly damaged, whereas damage to the largest individuals was mainly restricted to minor injuries. At a felling intensity of 10 to 12 trees per hectare, approximately 14 future crop trees (dbh > 35 cm) per ha survived felling without damage and another three were lightly injured.

There is no significant difference between the damage patterns of conventional and controlled logging. This is in accordance with the dynamics of gap formation which is largely determined by the architecture of the tree crown. Controlled felling did not influence the number of damaged trees within a gap. In both conventional (uncontrolled) and controlled experimental compartment, approximately 72% of the trees in a gap area were undamaged by felling.

The findings with regard to distribution of damaged and injured trees over size

TABLE 4.6. Felling damage: to commercial and potential trees, frequencies by diameter class and damage category

| Logging method                  | Dbh class (cm) | n/ha | Percentage in each category |           |                |               |             | Total |
|---------------------------------|----------------|------|-----------------------------|-----------|----------------|---------------|-------------|-------|
|                                 |                |      | Felled                      | Destroyed | Severe injured | Minor injured | Not damaged |       |
| Conventional logging (Mapane)   | 5-15           | 94   | 0.0                         | 11.2      | 3.5            | 4.0           | 81.3        | 100.0 |
|                                 | 15-35          | 56   | 0.0                         | 8.5       | 4.3            | 14.9          | 72.3        | 100.0 |
|                                 | 35-65          | 24   | 32.2                        | 5.1       | 3.9            | 11.8          | 47.0        | 100.0 |
|                                 | >65            | 6    | 52.2                        | 0.3       | 1.2            | 8.7           | 37.6        | 100.0 |
|                                 | >5             | 180  | 6.0                         | 9.2       | 3.7            | 8.6           | 72.5        | 100.0 |
| Controlled logging (Mapane)     | 5-15           | 85   | 0.0                         | 9.7       | 4.1            | 3.6           | 82.6        | 100.0 |
|                                 | 15-35          | 52   | 0.0                         | 10.1      | 4.0            | 12.3          | 73.6        | 100.0 |
|                                 | 35-65          | 28   | 35.6                        | 4.6       | 5.1            | 9.3           | 45.4        | 100.0 |
|                                 | >65            | 5    | 48.3                        | 0.8       | 0.9            | 8.5           | 41.5        | 100.0 |
|                                 | >5             | 170  | 7.3                         | 8.7       | 4.1            | 7.3           | 72.6        | 100.0 |
| Semi-controlled logging (Kabo)* | 5-15           | 83   | 0.0                         | 9.6       | 3.6            | 4.8           | 82.0        | 100.0 |
|                                 | 15-35          | 49   | 0.0                         | 8.7       | 2.6            | 13.2          | 75.5        | 100.0 |
|                                 | 35-65          | 32   | 8.1                         | 4.0       | 1.4            | 15.9          | 70.6        | 100.0 |
|                                 | >65            | 11   | 32.6                        | 1.4       | 0.5            | 11.3          | 54.2        | 100.0 |
|                                 | >5             | 175  | 3.5                         | 7.8       | 2.7            | 9.6           | 76.4        | 100.0 |

\* Source: Jonkers (1987)

classes are in line with Jonkers' study, taking into account that there are more large commercial trees in Kabo than in Mapane forest (see Table 4.6 and Jonkers, 1987).

#### 4.2.4 Appraisal of factors in felling damage

Controlled and directional felling are practised for more efficient logging operations and to restrict felling damage (see Section 3.1). Even though controlled felling (in compartments 2,1 and 2,2) was not aimed at reducing the impact of tree falls, the area of felling gaps was about 40% higher in the uncontrolled compartments (1,1 and 1,2) than in those in which controlled felling was applied. In order to explain the statistical evidence that controlled felling can reduce gap formation and hence tree damage (see Section 4.2.2), the role of major factors and parameters in the gap-forming process were appraised, namely: felling intensity, crown shape, presence of vines and climbers, and felling method.

*Felling intensity.* Harvesting has an impact on the remaining stand proportional to the number of trees felled per hectare. There is a direct and logical relationship between felling intensity and damage, with regard to area and number of damaged trees. This relationship was examined in CELOS Experiment 78/5 by Jonkers (1987) for three felling intensities: 15 m<sup>3</sup>/ha, 23 m<sup>3</sup>/ha and 46 m<sup>3</sup>/ha. These data have been adopted to determine the allowable harvesting intensity in the CELOS Harvesting System (see Chapter 7).

The present study compared the impact of various logging systems. All experiments were carried out at a fixed felling intensity (see Section 3.3.1). Variation between 23 m<sup>3</sup>/ha and 20 m<sup>3</sup>/ha is probably too small to explain substantial differences in felling damage.

*Crown shape.* The shape and size of a felled tree plays an essential role in the gap-forming process. A felling study in the Patamacca region (Mellink, 1981) indicated that most commercial trees have big crowns and consequently large gaps may be formed when such trees are felled. According to Rollet (1978), crown diameter is correlated with dbh but this relationship is not always strong. The ratio of these two variables varies during the life of a tree, and probably differs from one species to another (Rollet, 1978).

A small experiment was undertaken in one logging compartment to investigate the relationship between crown projection, dbh, and gap area (Henderson, 1984). The weak linear correlation ( $r^2 = 0.58$ ) was insufficient to allow reliable prediction of gap area from crown projection. The study is not detailed further as crown projection is of little interest in monitoring felling damage. Furthermore, the practical meaning of this analysis was restricted to the investigated site because of the small area sampled.

Although important in gap formation, crown size can be assumed to be geome-

trically the same in controlled and uncontrolled felling operations. Besides, composition and species distribution in the research area were similar for the experimental compartments (see Sections 3.3 and 4.1.1).

*Vines and climbers.* The presence of lianas may influence the pattern of felling damage. Woody climbers may link tree crowns so that felled trees cause damage to adjacent trees by breaking the crown or uprooting the tree completely. When tree crowns are joined by lianas, large gaps may be formed by chain effects (Fox, 1968; Putz, 1984).

The felling crew recorded the occurrence of lianas on felled trees. However, post-felling inspection showed that lianas were seldom the sole cause of extra felling damage. Approximately 28% of all felled trees were carrying lianas on the trunk and in the crown, but in all experimental compartments in less than 16% of felling gaps these woody climbers were connecting the felled tree with uprooted adjacent trees.

*Felling method.* After intensity, the method is probably the main factor governing felling damage. In an attempt to verify this, the working method of the felling crews were observed. Each step of the method used was identified, but their individual contribution to gap formation could not be determined.

Typical for conventional (uncontrolled) felling is lack of a systematic working method. The felling crew seek harvestable commercial trees, and when found, a good tree is felled immediately. There is no special order in the felling procedure. Intensive felling may be done in a small area where there is a cluster of commercial trees and excessively large gaps may be formed. There also is no special sequence for felling trees according to dimensions. Large trees may be felled first at the risk of damaging surrounding trees, including smaller marketable trees. More felling gaps with larger areas were formed in the uncontrolled than in controlled treatment compartments (see Fig. 4.6 and Table 4.5). One gap, 1500 m<sup>2</sup> in area, was almost 2.5 times the size of the maximum gap found in controlled experiments. Trees uprooted by chain effects were not observed in the controlled compartments.

The experimental compartments under controlled treatment were harvested by skilled operators trained for this system. The herring bone technique was applied to obtain a regular pattern of felled trees to facilitate terrain transport (see Section 3.1.1) and to restrict damage by avoiding joining of adjacent gaps and by considering surrounding trees.

Three other features of the working method should be mentioned in regard to damage restriction in the controlled experiments. Firstly, large overmature defective trees are generally felled in conventional exploitation. In the controlled experiments, such trees were not felled if close inspection showed rot or hollowness. These trees were left as seed bearers or to be dealt with in subsequent silvicultural interference. This helped to restrict felling damage as was confirmed

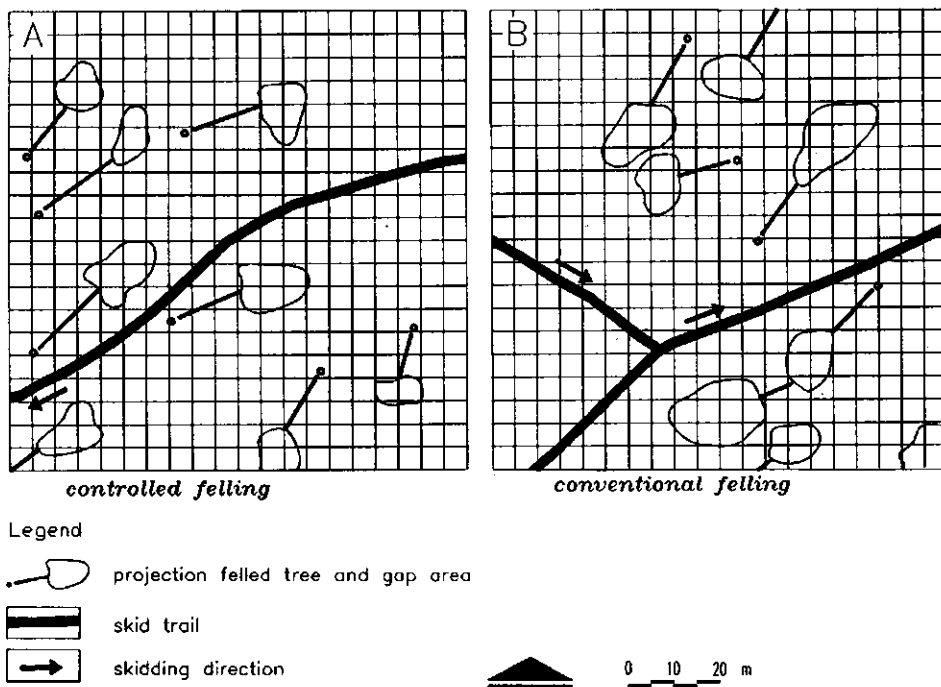


Fig. 4.6 Felling impact: examples of gap area distribution after conventional and controlled felling in the Mapane research area

as many rejected logs of large dimension were found in the uncontrolled compartments (Table 4.9).

Secondly in the uncontrolled compartments, trees obstructing the fall of felled trees were simply cut down, while in the controlled compartments, hang-ups were winched out with the wheeled skidder. The felling method itself also had a restricting effect because unhindered fall of trees was envisaged.

Thirdly in controlled compartments extra care was taken of surrounding trees before and during felling of sizable emergent trees to prevent a chain effect leading to extensive gaps. It is almost impossible to determine where the crown of a large tree will fall on the forest floor, since a distance of 40-60 m is difficult to estimate in luxuriant rain forest. Such trees were felled in the direction of relatively open forest or of forest poorly stocked with commercial trees. A quick but careful inspection of the site was required to determine the desired felling direction. In some cases, smaller surrounding trees were felled first to prevent damage.

Turning tree felling into a careful forest operation helped to reduce damage. After each tree fall, the situation was re-assessed to decide which tree should be felled next and how this should be done. Tree felling was subjected to a synthesis between harvesting efficiency and damage restriction.

### 4.3 Skidding impacts of the second harvest

In production forest, the opening of skidding trails for timber harvesting should not simply be considered to be stand damage or clearing of forest vegetation (see Table 1.1). These trails are needed to transport logs to the access roads, and for both efficiency and forest protection, a skid trail network should be limited to 5-8% of the harvested compartment (Froehlich et al., 1981; Conway, 1982; Staaf and Wiksten, 1984). Stand damage is then the excess of trails, paths and skidding gaps caused by improper logging operations (see Section 3.3.6). Skidding operations can be channelled along the established network, and thus the study focused on the development of controlled skidding methods, with the conventional method as a reference (null-treatment).

#### 4.3.1 Effect of logging systems on trail area

The area of skid trails and skidding gaps in the controlled experiments was approximately 50% less than that in the uncontrolled experiments (see Table 4.7). There also is little difference in trail area between the six controlled compartments.

*Conventional skidding.* The uncontrolled logging experiments exemplify inefficient and damaging harvesting operations, similar to the first timber harvest in the Mapane forest (see Section 4.1.3). One feature is the relatively high density (compared with the standard density of 5-8% for efficient skidding) of trails and

TABLE 4.7. Skidding damage: trail area in the experimental compartments

| Logging method       | Treatment code | Area (ha) | Trail area (% of area) |               |               |       |
|----------------------|----------------|-----------|------------------------|---------------|---------------|-------|
|                      |                |           | Main trails            | Branch trails | Skidding gaps | Total |
| Conventional logging | 1,1            | 20        | 4.8                    | 5.5           | 4.2           | 14.5  |
|                      | 1,2            | 20        | 5.0                    | 5.8           | 5.2           | 16.0  |
| Controlled logging*  | 2,1            | 10        | 1.2                    | 5.1           | 1.0           | 7.3   |
|                      | 2,2            | 10        | 1.2                    | 4.5           | 1.5           | 7.2   |
| Controlled logging   | 3,1            | 10        | 2.3                    | 3.6           | 1.1           | 7.0   |
|                      | 3,2            | 10        | 1.8                    | 4.2           | 0.8           | 6.8   |
| Controlled logging** | 4,1            | 20        | 2.4                    | 2.5           | 0.5           | 5.4   |
|                      | 4,2            | 10        | 1.3                    | 3.9           | 0.5           | 5.7   |

\* With directional felling

\*\* With winching

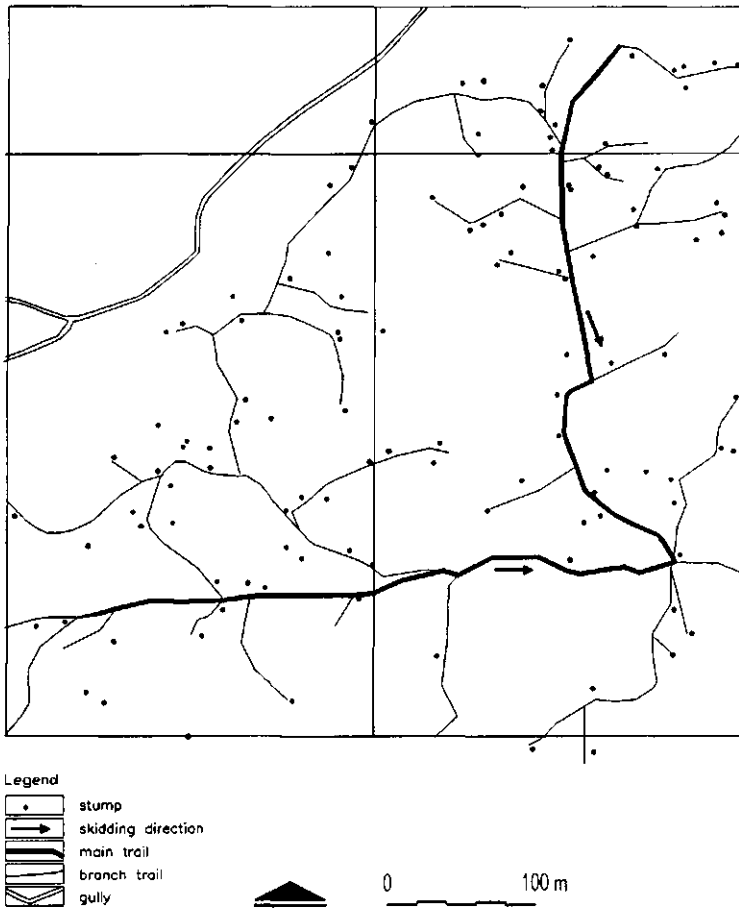


Fig. 4.7 Skidding impact: actual skidding pattern after conventional logging in experimental compartment 1,1 in the Mapane research area

skidding gaps (14.5% in unit 1,1 and 16.0% in unit 1,2), another is the trail pattern. There are too many trails in relation to the number and locations of felled trees. There are many winding trails with acute intersections ( $> 60^\circ$ ) between main and branch trails and many cross links (see Fig. 4.7).

Approximately 5% of the area is covered by skidding gaps (that is 30% of the total skid trail area), which means that a substantial part of the damage is caused by the working method (see Section 4.3.2). The distinction between main and branch trails is not very clear implying that intensive movement is not limited to main trails, which is necessary to restrict soil compaction (see Chapter 5). More efficient trail design based on two main trails could easily reduce the affected area with 40% (see Fig. 4.8). In terms of avoidable skidding trails, uncontrolled logging proved to be quite damaging.



**Controlled skidding.** The area of skid trails and skid gaps varied from 5.4 to 7.2% in controlled experiments (see Table 4.7). A very small difference was found between units with and without directional felling. The lowest trail density was found in those units where winch skidding was used.

A section of the trail system in controlled logging is presented in Figure 4.9. A more efficient log flow could be obtained than in conventional logging but some branch trails were found to deviate from the original design. In spite of close supervision, the skidding crew made three unplanned trails to the truck road and two trails were not opened according to the original design of a 10% lower trail density. Yet, the average density of 7% was close to the target of 5-8%.

Less than 2% of the area was occupied by main trails and less than 1.5% by skidding gaps. There was a clear distinction between main and branch trails and

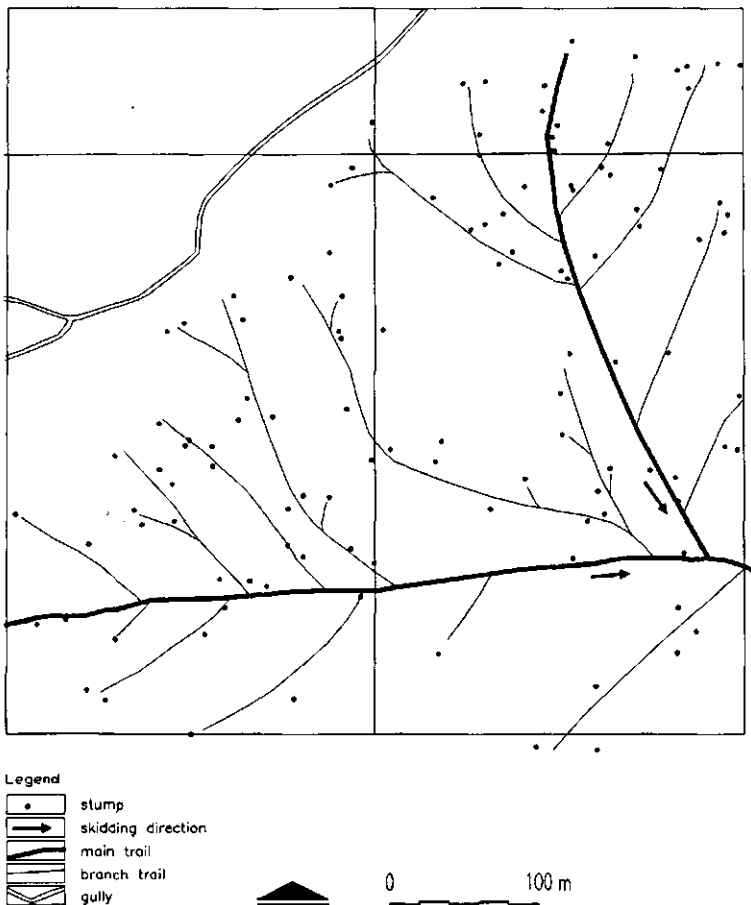


Fig. 4.8 Skidding impact: planned skid trail pattern in experimental compartment 1,1 in the Mapane research area

trails did not intersect at sharp angles. The network as a whole allowed for fairly efficient skidding (Chapter 6).

*Controlled winching.* This method was based on the establishment of the complete skid trail network (main and branch trails) before logging commenced (Section 3.1.4). The result was a regular pattern with straight or slightly winding trails and well joined branch and main trails. This felling pattern (experimental compartment 4,1) is shown in Figure 4.10 for 117 logs. Of these, 47 logs were close to the trails and could be skidded without prewinching, while 70 logs had to be winched to the trails.

Winch skidding was fully controlled and skidding damage in a narrow sense was almost negligible. The calculated proportion of trail and skidding gap area of 5.5% must be considered to be the minimal achievable density for extracting logs.

Another measure was to reduce the log length in winching operations in order to minimize skidding gaps. In experiment 4,1 logs were winched in full length, while in experiment 4,2 log length was restricted to 8-10 m. The resulting winching gaps were the same (0.5%), indicating that log length has probably little effect on winch trail area. This is discussed further in Chapter 6.

#### 4.3.2 Effect of skidding methods on tree damage

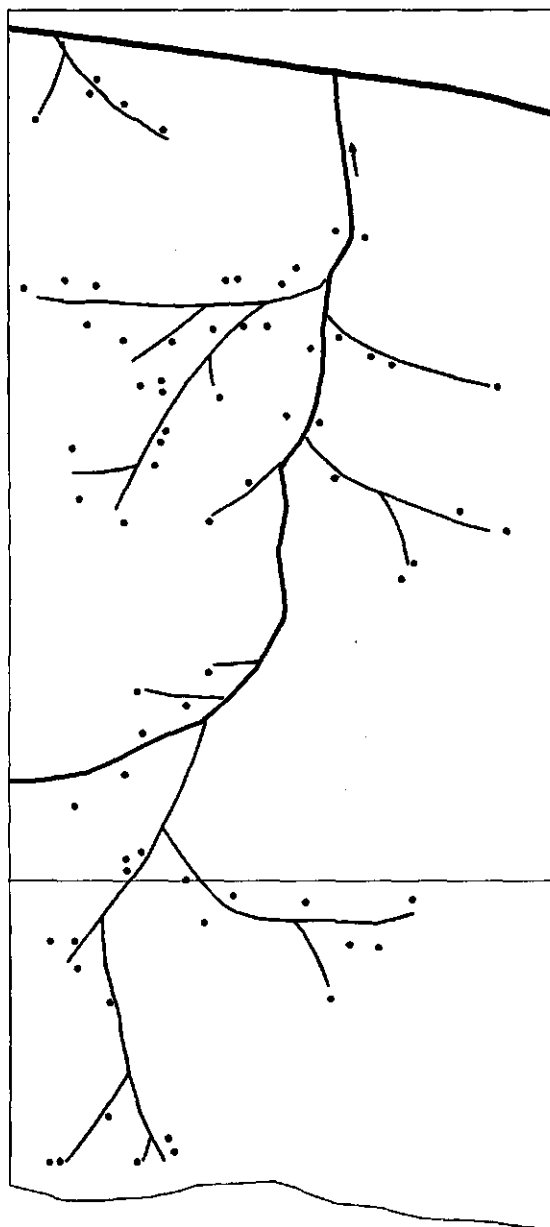
When logs are skidded from the stump area to forest landing, trees along the trails

TABLE 4.8. Skidding damage: percentage of boundary trees (dbh > 15 cm) with stem injuries per damage category in the experimental compartments

| Logging method       | Treatment code | Percentage in each category |                |               |             |
|----------------------|----------------|-----------------------------|----------------|---------------|-------------|
|                      |                | Destroyed                   | Severe injured | Minor injured | Not damaged |
| Conventional logging | 1,1            | 4.2                         | 10.1           | 30.1          | 55.6        |
|                      | 1,2            | 2.3                         | 12.5           | 21.5          | 63.7        |
| Controlled logging*  | 2,1            | 0.0                         | 5.9            | 15.9          | 78.2        |
|                      | 2,2            | 0.0                         | 3.0            | 12.0          | 85.0        |
| Controlled logging   | 3,1            | 1.2                         | 4.3            | 14.3          | 80.2        |
|                      | 3,2            | 0.0                         | 4.7            | 14.1          | 81.2        |
| Controlled logging** | 4,1            | 2.6                         | 4.5            | 8.5           | 84.4        |
|                      | 4,2            | 2.0                         | 3.6            | 11.6          | 82.8        |

\* With directional felling

\*\* With winching



Legend






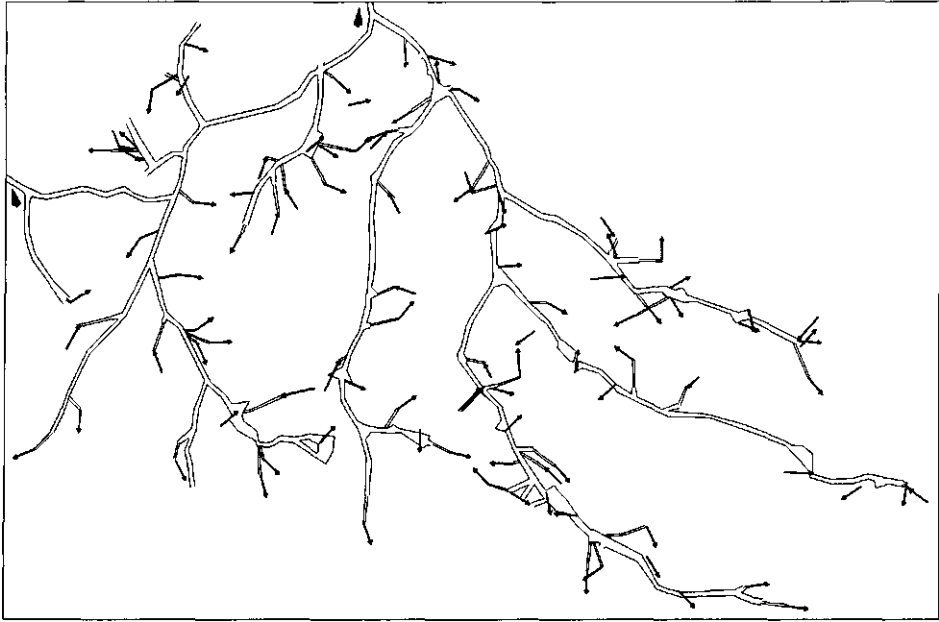
-  stump
-  aligned branch trail
-  pre-opened primary trail
-  truck road
-  skidding direction



Fig. 4.9 Skidding impact: actual skidding pattern in controlled logging in experimental compartment 3,1 in the Mapane research area



Legend

- trunk and crown of felled tree
- skid trail
- winch trail
- skidding direction
- log collection place

0 100 m

Fig. 4.10 Skidding impact: actual skidding pattern in winch logging in experimental compartment 4,2 in the Mapane research area (Source: Oosterholt, 1986)

may be damaged by the moving skidder or by the sweeping load. Recording of this type of damage, mainly bark injury, was described in Section 3.3.6, and the results are given in Table 4.8.

The significantly higher incidence of damage in conventional skidding was directly related to the pattern of the skid trail network and the attitude of the skidder operator. The sweeping effect of logs and the direct action of skidder wheels was considerable on the winding trails in uncontrolled experimental compartments, causing breaking, uprooting and bark damage to boundary trees. This damage was almost completely avoided in controlled compartments except where winching was applied. Trees may block logs being winched to the skid trails and, especially smaller trees, may occasionally be uprooted by the pulling force of the winch line. Approximately 80% of trees destroyed in skidding and winching operations were of dbh < 30cm. Larger trees might be hit and damaged but survive with severe or minor injuries. The frequency of bark injuries was significantly higher in the conventionally harvested compartments.

The conclusion however, that conventional skidding causes more damage to boundary trees than controlled skidding should be made with some reservation. The incidence of damage in controlled logging is very much reduced by a pre-established skid trail system. Well designed and constructed trails are wide enough (3.6 - 4.0 m) to allow free passage of the loaded transporting vehicle. The chance of damage to boundary trees is low on such trails.

The actual number of damaged remaining trees along trails was 15 per ha in conventional skidding, and 5-6 trees per ha in the three types of controlled skidding. Boundary trees are more exposed to root damage which might lead to wood rot and further degradation. Thus it is disputable whether boundary trees should be saved as future crop trees.

#### 4.4 Wood damage

Damage to the harvested product, felled trees topped and bucked to one or more logs, was classified as an affected subsystem (see Table 1.1) although these logs are subjected to extraction from the forest. However, for harvesting purposes this type of damage is important from a point of view of efficiency and, indirectly, also ecology.

Measurement of wood damage is discussed in Section 3.3.7, and results given in Table 4.9. In all categories, the incidence of damage was substantially higher in the uncontrolled experimental compartments. The higher rate of felling defects was

TABLE 4.9. Wood damage: percentage of rejected logs by damage category in the experimental compartments

| Logging method       | Treatment code | Percentage in each category |                 |            |                |
|----------------------|----------------|-----------------------------|-----------------|------------|----------------|
|                      |                | Felling defects             | Natural defects | Left-overs | Damage (total) |
| Conventional logging | 1,1            | 6.2                         | 8.7             | 13.4       | 28.3           |
|                      | 1,2            | 7.5                         | 7.2             | 9.6        | 24.3           |
| Controlled logging*  | 2,1            | 2.3                         | 4.6             | 1.1        | 8.0            |
|                      | 2,2            | 1.6                         | 3.7             | 0.8        | 6.1            |
| Controlled logging   | 3,1            | 2.1                         | 3.5             | 2.0        | 7.6            |
|                      | 3,2            | 2.2                         | 3.8             | 1.8        | 7.8            |
| Controlled logging** | 4,1            | 2.7                         | 3.9             | 1.9        | 8.5            |
|                      | 4,2            | 1.8                         | 2.9             | 2.1        | 6.8            |

\* With directional felling

\*\* With winching

the result of the felling method and organization of the harvesting work (see Chapter 6). More trees with natural defects were felled in the conventional operations than in controlled harvesting, affecting not only the number of rejected logs but also damage to remaining trees (see Section 4.2.4). Finally, poor organization in conventional logging was the reason for the high proportion deteriorating logs during storage in stump areas and landings.

Wood damage means loss of the harvested product and consequently loss of trees and forest because more trees should be harvested to meet the production targets. This type of damage can easily be controlled by appropriate methods and is therefore important for the development of a forest management system.

## 4.5 Conclusions

Terrain transport should be organized for efficient and rapid flow of felled timber from the forest to the truck roads. Therefore the skid trail network needs to take account of the truck road system as well as the topography and soil bearing capacity. The recorded features of the trail system illustrate the uncontrolled character of the first timber harvest.

Skidding impacts were comparatively high. While the impact of felling was difficult to recognize after ten years and barely distinguishable from natural chablis formation (see Section 4.1.2), skidding damage was still visible, although mainly restricted to intensively travelled sites. The variation in trail density indicates selective harvesting and that not all commercial trees were found by felling and skidding crews. The irregular trail network and numerous creek crossings are strong evidence of chaotic forest exploitation.

Although less effective in tropical rain forest than in temperate forests, controlled felling has restricted the impact of felling (Section 4.2). Careful preparatory work was the basic difference between this system and the conventional system. Preparation enabled the felling crew to judge how a tree could best be felled to minimize damage to both remaining stand and the tree itself. This has contributed to better production performances, less forest damage, and higher quality of harvested logs.

Careful directional felling will facilitate skidding work and reduce damage because logs are oriented according to the skid trails (herringbone felling). Stand damage was not further reduced by introducing this method, possibly because real directional felling was not accomplished. Felling was organized and efficient in virtually all the compartments with controlled felling and the results did not differ significantly from directional felling.

The comparison of the conventional and controlled systems showed that planned operations were effective in restricting skidding damage simply because trail density was fixed by management objectives (Section 4.3). The controlled system also had a lower incidence of damage to boundary trees (bark injuries) and harvested logs (Section 4.4).

## 5 Skidding impacts on soil

Use of wheeled machinery subjects forest soil to complex physical and chemical processes, the extent of which is largely determined by the composition and structure of the soil, biological agents (soil fauna and flora) and characteristics of the machines used.

The soil structure, that is the spatial arrangement and bonding of soil particles, is basically a three phase matrix of solid material, air and water. The latter two are complementary in that they may replace one another proportionally. The mineral particles are bonded on contact points by cohesion forces and form a system of pores and voids where water and air can flow. The finer pores or capillaries also contribute to the soil cohesion strength because of the binding force of water under negative pressure. The bonding or cementing properties of organic matter favour the cohesive strength. Thus soil strength, that is resistance to structural changes such as compaction, deformation, and breaking, is largely determined by the composition, structure and moisture content of the soil matrix.

A skidding machine working in the forest causes static and dynamic loading of the soil. In describing the stress matrix near the contact area of soil and tyres (or tracks), a soil volume element is considered as a micro cube, having one axis ( $x$ ) perpendicular and two ( $y$  and  $z$ ) parallel to the contact area. The gross vehicle weight, that is the total weight of the skidder including the load, and rimpull (driving force) are transmitted to the soil elements as normal stress ( $\sigma_1$ ) perpendicular to, and shear stresses ( $\sigma_2$  and  $\sigma_3$ ) in the contact area. The normal stress will act as a compression force and the shear stresses as breaking forces. According to stress theory, the interactions of these stresses can be expressed through the principal stresses  $\sigma_1$ ,  $\sigma_2$ ,  $\sigma_3$  in a stress matrix (Fig. 5.1). Although the stress matrix is more complicated and also determined by soil properties and tyre characteristics, this simplified model is useful to explain soil behaviour under stress conditions (Koolen, 1986).

As a reaction to normal stresses, soil elements may be compressed until increased strength leads to a new equilibrium. As a result, the soil is compacted and the bulk density (the volume fraction of solids) increased. Compaction is a component of soil damage (see Table 1.1). Compacted soils have reduced water retention, infiltration and aeration capacities, which hampers root penetration. These effects reduce site productivity and increase risk of erosion and further degradation.

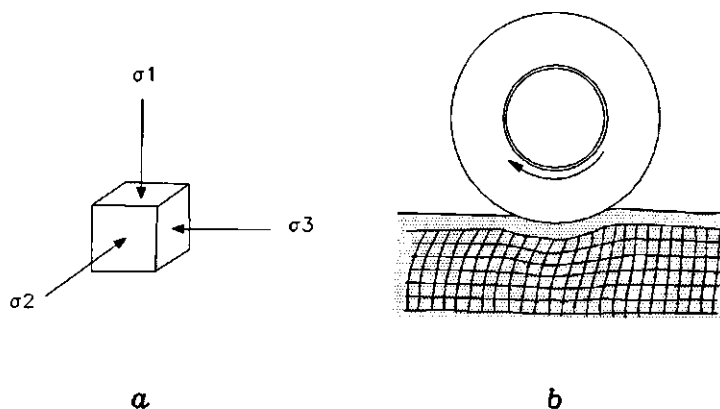


Fig. 5.1 Soil volume element under loading (a) and example of soil wheel interaction involving a large number of soil volume elements (b) (Source: Koolen, 1986)

Shear stresses may exceed cohesion strength and cause soil failure when tyres or tracks penetrate in the forest floor, leaving impressions and ruts on the trails. This type of damage not only seriously limits vehicle mobility but is also an agent of further soil degradation, for instance where rain water in ruts cannot be drained normally, the skid trail is converted into a shallow channel.

Compaction and rutting in skid trails were studied in the research area. The effects of travelling intensity of a wheeled skidder were also examined. As already explained in Section 3.3, tests of the undisturbed soil was included for comparison. Soil damage was assessed as changes in dry bulk density, hydraulic properties, and penetration resistance.

TABLE 5.1. Textural composition of undisturbed forest soils in skid trail profiles to a depth of 70 cm

| Trail (no) | Particle fraction (%) |      |      | Soil type             |
|------------|-----------------------|------|------|-----------------------|
|            | sand                  | silt | clay |                       |
| 1          | 51                    | 5    | 44   | sandy clay            |
| 2          | 61                    | 5    | 34   | sandy clay loam       |
| 3          | 69                    | 7    | 24   | sandy clay loam       |
| 4          | 54                    | 8    | 38   | sandy clay            |
| 5          | 83                    | 6    | 11   | loamy sand            |
| 6          | 81                    | 5    | 14   | loamy sand/sandy loam |
| 7          | 55                    | 6    | 39   | sandy clay            |
| 8          | 54                    | 6    | 40   | sandy clay            |



## 5.1 Soil types and rut formation

Physical soil properties are greatly influenced by the soil texture, that is the particle-size distribution (Hillel, 1980). Rut formation in trails was examined and related to textural composition of the investigated soils.

The results of the particle-size analysis of soil samples of the eight trails are summarized in Table 5.1 and Figure 5.2. Three soil types were identified: sandy clay, sandy clay loam and loamy sand. All soil types have a high percentage of sand throughout the profile, whereas the silt fraction is low and has little effect on soil classification according to the textural triangle.

The textural composition of the skid trails varied greatly with soil depth. The silt content was relatively constant, in each profile, varying slightly around a median of 6.5%. The clay fraction increased with soil depth in most profiles and was accompanied by a decrease in the total sand fraction. This relationship was less significant for the single fractions (coarse, medium and fine sands) and most distinctive on sandy clays and loamy sands (Table V.1, Appendix V).

There was a substantial vertical variation in soil texture within profiles. For

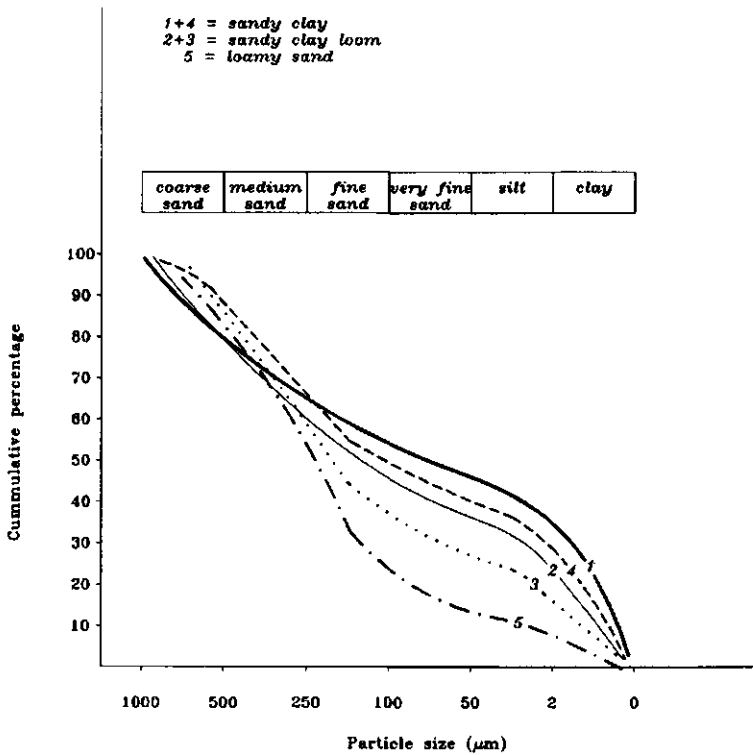


Fig. 5.2 Soil textures in the Mapane research area

instance, trial 1 (see Section 3.4) was predominantly sandy clay. The undisturbed profile (U) was composed of a sandy clay loam A horizon and sandy clay B and C horizons, as the boundary between sandy clay loams and sandy clays has a clay content of 35%, according to the textural triangle (see Koorevaar et al., 1983). The A horizon in rut 2 (R 2) was a sandy clay loam and not, as may be expected, a sandy clay. Found in all profiles, this type of variation marks the heterogeneity of the soil and complicates the analysis of soil composition as a strength factor.

The soil types identified are typical of the Zanderij formation. According to Bennema (1982), the relationship between clay content and soil depth of these soils is linear with the logarithm of the soil depth. Low silt and organic matter content are also typical of these soils. The sand fractions are irregularly distributed with medium sand as the largest and coarse sand as the smallest fraction. Stability is poor due to the near absence of bounding agents such as iron oxides. Forest clearing with heavy machinery can lead to compaction of both the topsoil and subsurface soil (Bennema, 1982).

All eight skid trails investigated showed similar rutting patterns. Trails consisted alternately of stable trafficable parts and rutted sections. The maximal affected section was examined for each trail (see Table 5.2). The primary trails (trails 1-4) were disturbed the most having sections with rut depths up to 34 cm below ground level. Secondary branch trails (trails 5 and 6) were slightly disturbed showing a mean rut depth of 5 cm only.

The process of rut formation was observed in trails 7 and 8 after each round trip of a loaded skidder (see Table 5.2). Rut depth increased with increasing travelling intensity in trail sections susceptible to disturbance. Between the fifth and ninth round trip tyre penetration was retarded substantially.

As already mentioned, little difference in rutting patterns was observed and no

TABLE 5.2. Tyre ruts in heavily disturbed sections of used and test trails

| Trail (no)         | Section length (m) | Depth of ruts (cm) below ground level |                  |                  |
|--------------------|--------------------|---------------------------------------|------------------|------------------|
|                    |                    | Minimum                               | Median           | Maximum          |
| <b>Used trails</b> |                    |                                       |                  |                  |
| 1                  | 18                 | 17                                    | 22               | 34               |
| 2                  | 22                 | 11                                    | 20               | 23               |
| 3                  | 31                 | 21                                    | 26               | 32               |
| 4                  | 24                 | 19                                    | 21               | 23               |
| 5                  | 16                 | 4                                     | 5                | 5                |
| 6                  | 28                 | 5                                     | 5                | 5                |
| <b>Test trails</b> |                    |                                       |                  |                  |
| 7                  | 30                 | (1st pass)<br>4                       | (5th pass)<br>10 | (9th pass)<br>15 |
| 8                  | 23                 | 5                                     | 10               | 17               |

relationship could be determined with textural composition of the trails. A high clay fraction combined with high field moisture content in trail sections may have induced rut formation, but this could not be verified from soil samples from affected trails. The travelling intensity of the skidder was a decisive factor given the results of the traffic intensity test and the substantial difference in tyre penetration on primary and secondary trails. The practical consequence is that skid trails need to be carefully designed, preferably on well-drained, stable soils, and that rutted trails should be repaired regularly to prevent further deterioration.

## 5.2 Soil compaction and bulk density

Dry bulk density (volume weight of the solid fractions) is a parameter of soil strength. Lightly structured soils of low density can easily be compacted when loaded, and consequently, the density is increased. Soil strength increases with increasing density, provided that other factors remain the same, and thus compacted forest soils may be of improved trafficability. Changes in density can be used to explain soil behaviour under loading conditions. However, this relationship is complicated and as already stated is also a function of other soil factors (Soane et al., 1981a).

Dry bulk density ranged from 1.09 g/cm<sup>3</sup> for undisturbed topsoil to 1.71 g/cm<sup>3</sup> for compacted soil at 60 cm depth (see Table V.2, Appendix V). In a similar study, dry bulk density of Ferralsols under rain forest cover was found to vary from 1.28 g/cm<sup>3</sup> in the upper 5 cm to 1.50 g/cm<sup>3</sup> at a 1.50 m depth (Vierhout, 1983). This variation is not the result of compaction but of static forces in the soil (soil pressure) and variations in soil composition and organic matter content, for instance, increasing clay content. The high bulk densities of disturbed soils in the present study are most likely related to a high degree of compaction.

The relationship between degree of compaction (increase of bulk density) and loading conditions (type of treatment) was established for four situations (Table V.2, Appendix V).

*Undisturbed soils.* The undisturbed soil in trails 2, 5 and 6 (Table V.2) showed a bulk density pattern similar to those found in other areas of the Forestry Belt (Vierhout, 1983; van der Steege, 1983). Soils of trails 1, 3 and 4 had a lower density in the upper (0-7 cm) zone but the pattern in the subsoil was similar to that of the other trails. The upper zone in these trails is obviously looser in structure with more pores and voids due to greater activity of soil fauna and rooting activity. The higher content of organic matter in the topsoil than in the subsoil is another reason for the lower bulk density. A density increase of 17% to a depth of 60-65 cm was calculated for most soils.

The relationship between soil composition and dry bulk density was not obvious but was in accordance with textural variation. Increasing density was found to be accompanied by increasing clay and decreasing organic matter content (Table V.2).

*Primary skid trails two years after logging.* These observational units (trails 1 and 2) were part of an old primary trail used two years previously. The trail was covered with a low vegetation of herbs and young regeneration, but the tracks of wheeled skidders were still visible. The bulk density of the undisturbed soil (U) was compared with that of the wheel ruts (R 1 and R 3) and the inter-wheel section (R2) to assess the effects of compaction (Table V.2, Appendix V).

The matrix of bulk density records was tested statistically with ANOVA. Observation points (U, R 1, R 2, R 3) were considered as treatments in a two-way test. No significant increase of bulk density was found. The higher values in the matrix are within the range of normal variation of bulk density with soil depth. Wheel ruts and space between the ruts where the skidded log had affected the soil were compacted to a similar extent.

The differences between treatments in trail 1 were not negligible only when the upper soil (0-7 cm) in which effective stresses are substantially higher than in lower layers were considered. Bulk density was 27% higher in the upper soil, but only 9% at a depth of 10-15 cm compared with the undisturbed soil. The low initial density of  $1.15 \text{ g/cm}^3$ , and consequently the low resistance to compression, was possibly the cause of this compaction. At a depth of 10-15 cm, where a density of  $1.33 \text{ g/cm}^3$  was measured, no additional increase was found.

In trail 2 loading did not result in an apparent increase in bulk density. The high initial density in the topsoil of  $1.27 \text{ g/cm}^3$  probably explains the unaffected matrix of the bulk density. The values of  $1.54 \text{ g/cm}^3$  and  $1.51 \text{ g/cm}^3$  at a depth of 40-55 cm should also be considered as normal variations.

No clear relationship was found between bulk density and textural composition. Trail 1 consisted of sandy clay and trail 2 of sandy clay loam, but differences in bulk density were minor compared to the distributional patterns of the profiles (see Table V.2).

On the basis of the data analysed, it may be concluded that dry bulk density in the trails was moderately affected by log transport. The primary trails were intensively used but possibly skidding was limited to the dry season when the soil moisture content was relatively low.

*Primary skid trails eight years after logging.* Trails 3 and 4 were partly covered with a vegetation consisting of saplings 2 to 6 m high and partly with herbs and seedlings. Eight years after logging, tracks were still visible and some parts of the trails were almost without vegetation. A bulk density matrix similar to the previous case was calculated for this old primary skid trail. The upper profiles of both observational units had light textured topsoils and consequently a low bulk density. The upper soil was compressed, which is reflected by the significant differences in bulk density between compacted and undisturbed soil of 37% in trail 3 and 25% in trail 4. This compaction extended throughout the profile, although the statistical significance decreased with increasing soil depth because of increasing static soil stress. The high bulk densities of  $1.51$  and  $1.54 \text{ g/cm}^3$  in trail 3 at a depth of

50-65 cm cannot be explained by compaction because of the reduced normal stress at that depth (Table V.2).

Both soils were different in composition. Trail 3 was a sandy clay loam and trail 4 a sandy clay, but the fractional distribution varied to such an extent that no relationship could be established between texture and bulk density. Only the effects in the topsoil were significant and apparently a result of repeated loading of a soil of low strength.

*Secondary skid trails one year after logging.* The impact of a few skidder movements (one to three round trips from stump to primary trail) was examined in two observational units (trails 5 and 6). Statistical tests showed no significant increase in bulk density (Table V.2, Appendix V). The somewhat higher values in the tracks were all within the limits of variation of test results. When other factors, such as field moisture content, water retention and hydraulic conductivity are excluded, then it may be concluded that low travelling intensity on (loamy) sandy soils has no measurable effect on the bulk density. The soil was not compressed, even the topsoil with an initial bulk density of  $1.22 \text{ g/cm}^3$  was not affected, and at least trafficability was not affected. Further interpretation of this case is given in Section 5.5.

*Skid trails after repeated loading.* The effects of travelling intensity were investigated in two observational units (trails 7 and 8). Compaction of a new, previously unused skid trail was assessed after each pass of a loaded wheeled skidder by determining bulk density, penetrometer strength and other soil factors (see Section 3.3).

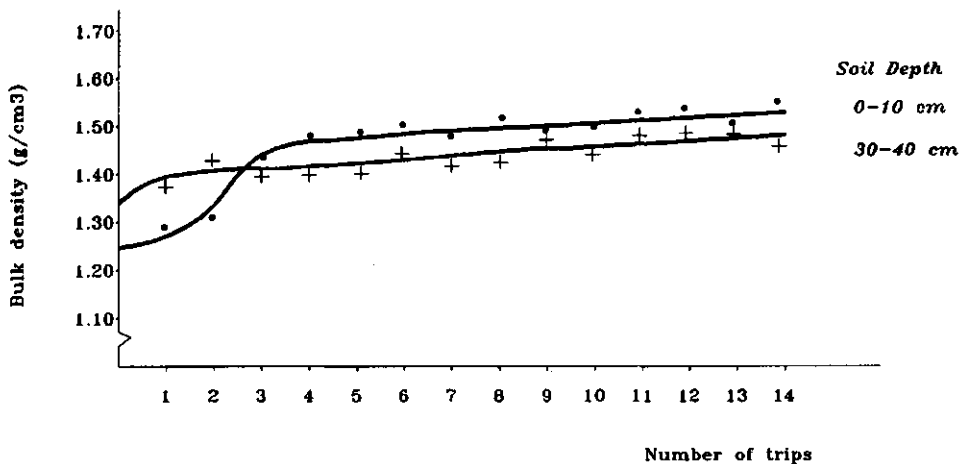


Fig. 5.3 Bulk density at 0-10 and 30-40 cm depth in relation to traffic intensity

In the topsoil (0-10 cm) bulk density increased until the third round trip of the skidder and then only slightly until the 15th pass (Fig. 5.3). In the subsoil (30-40 cm), bulk density increased gradually with travelling intensity until the ninth pass after which no further increase was recorded. Soil compaction was noticeable after only two or three round trips in the sandy clays. No experiment was carried out on the loamy sands.

The experiment indicated that wet soil is more susceptible to compaction than a drier soil. Dry bulk density in the top layers increased with gravimetric moisture content (see Fig. 5.4), but the effect of the number of round trips on the increase of the dry bulk density was largely the same.

### 5.3 Soil compaction and hydraulic properties

When the spatial arrangement of soil particles is disturbed by machine action, the soil may become more compacted because pores and voids are filled with finer particles. This may affect water conductivity. Changes in hydraulic conductivity (K factor) were measured using a standard laboratory method (Section 3.3). Values of the chosen parameter, the saturated hydraulic conductivity, are listed in Table V.3, Appendix V.

*Primary skid trails two years after logging (trails 1 and 2).* The undisturbed soil was well drained in the A and B horizons down to a depth of 50 cm in trail 1 and to 35 cm in trail 2 (Table V.3). In the C horizon (down to 70 cm), K was 450 mm/day and 380 mm/day in trails 1 and 2 respectively. A substantially lower K was measured in the trail ruts. The effect was more significant in the upper horizons (A and B). In spite of the considerable variation in soil profiles, it may be concluded

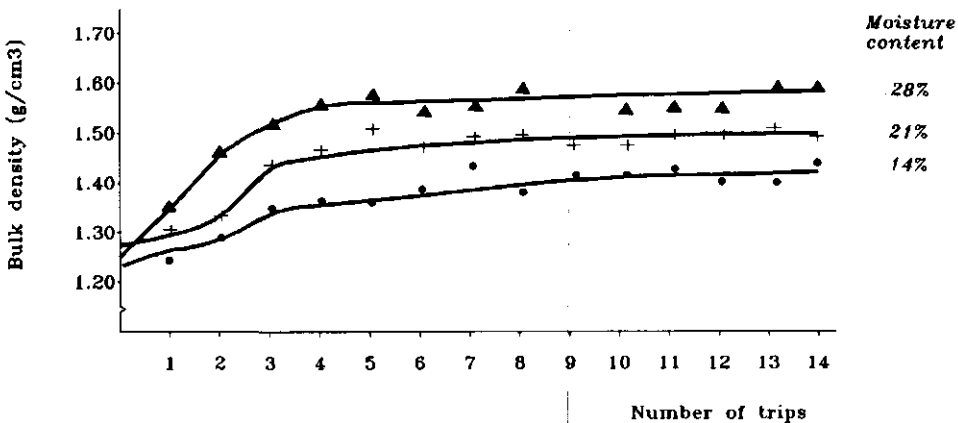


Fig. 5.4 Bulk density at 0-40 cm depth in relation to soil moisture content and traffic intensity

that skidding has disturbed the topsoil to such an extent that saturated hydraulic conductivity has been reduced by approximately 90%.

*Primary skid trails eight years after logging (trails 3 and 4).* In the sandy clay (trail 4) and sandy clay loam (trail 3) profiles, the effects of compaction on hydraulic conductivity were still obvious. In trail 3, K was reduced in the upper horizon from 1320 mm/day to 290 mm/day (R 1), 210 mm/day (R 2) and 120 mm/day (R 3) respectively (Table V.3). This effect was also present in the upper horizon of trail 4, but the low initial water conductivity of the lower horizons was not influenced by skidding.

*Secondary skid trails one year after logging (trails 5 and 6).* Constructed on undisturbed sandy soils (see Table 5.1), trails 5 and 6 were well drained giving a high K factor in all horizons (Table V.3). Skidding at low intensity during log collection, that is only one to three trips from the stump area to the primary trails, affected the top horizon only, while the lower layers maintained normal hydraulic conductivity. The sandy topsoil texture, indicating a good pore and capillary system, was disturbed and consequently effective conductivity was substantially reduced. Subsoil was unaffected, probably because of the low travelling intensity. However, even low traffic movement may noticeably reduce water infiltration capacity of the soil.

*Skid trail after repeated loading (trail 7 and 8).* A few passes of the skidder, one on trail 8 and two on trail 7, were sufficient to reduce hydraulic conductivity in the upper horizon significantly from 1750 mm/day to 240 mm/day in trail 7 and from 1220 mm/day to 210 mm/day in trail 8 (Table V.3). A similar reduction of the K factor was found in the lower horizons of trail 7 where initial conductivity decreased from about 600 mm/day to 200 mm/day. There was no further decrease of the K factor after the second pass.

Soil water and soil air characteristics gave no clear indication of affected soil properties (see Table V.3). The moisture content pattern at field capacity (pF 2) was apparently not influenced by skidder activity and was comparatively uniform in all profiles examined. In the most cases field moisture content was close to field capacity, confirming the state of saturation of the rain forest soils.

Soil air volume at pF 2 showed an irregular pattern. Decreasing air volume as a result of skidder activity was only observed in trail 2 where air volume was substantially lower than in the undisturbed soil (Table V.3). This effect was less convincing in the A horizon of trail 2. The air volume in the profiles of ruts in trails 1, 2 and 4, ranging from 1 to 10% (see Table V.3), are considered to be low for plant growth compared with the mean critical values for sands and clays of 20% and 10% respectively (Hillel, 1980).

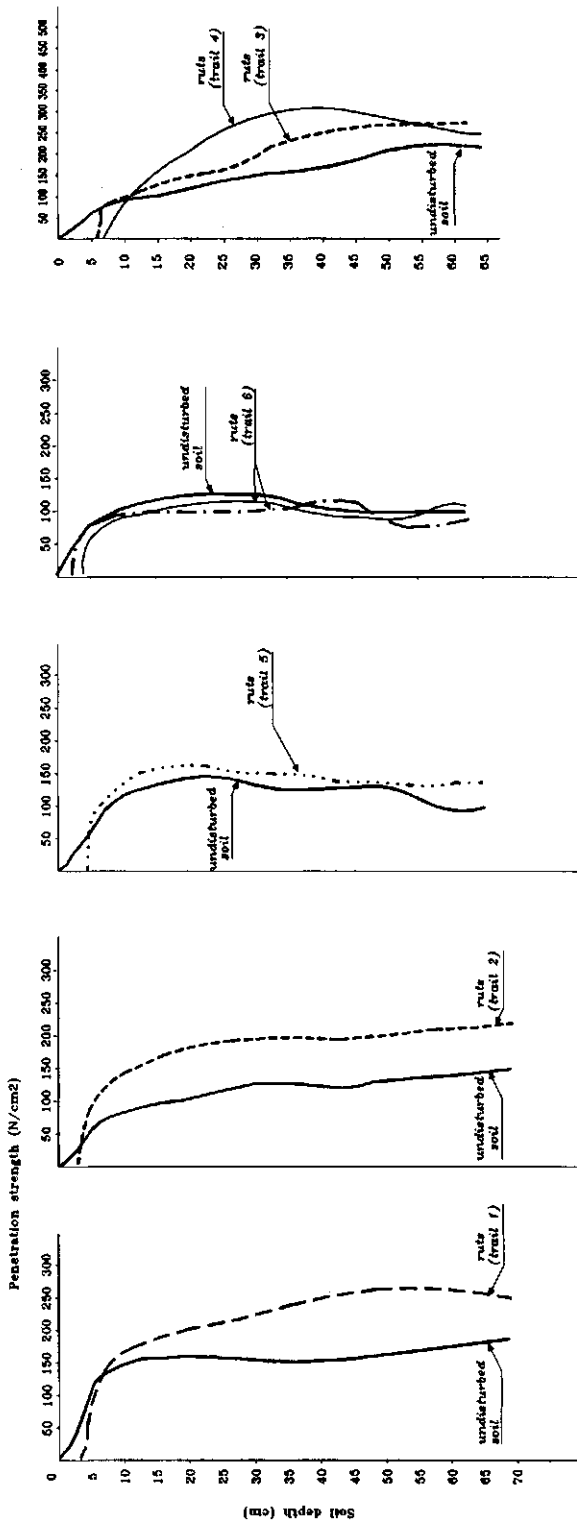


Fig. 5.5 Penetration strength of undisturbed soil and skid trails



In the eight trails, soil hydraulic conductivity was affected by skidder movement. All four dominant soil types (see Table 5.1) appeared to react in a similar way, probably because the soil structure was more disturbed by intensive skidder movement than by other factors. The topsoil was most susceptible. Given the relatively minor changes in field moisture content and air volume, the significant reduction of the hydraulic conductivity of the topsoil was probably mainly caused by smearing effects (wheel impacts) than by volume reduction.

#### **5.4 Soil compaction and penetration strength**

The penetrometer measurements of ruts in skid trails are presented in Figures 5.5 and 5.6. The measurements were related to the reference level of the undisturbed soil (see Section 3.4). Higher penetration resistance was measured in all skid trails where soil compaction was assumed to result from repeated skidder movement. This was the case for the old primary skid trails (trails 1-4) where penetration strength at a 30 cm depth varied from 200 N/cm<sup>2</sup> in the ruts to 150 N/cm<sup>2</sup> in undisturbed soil (see Fig. 5.5). The strength of the undisturbed soils varied substantially from 75 N/cm<sup>2</sup> (trails 2 and 8) to 150 N/cm<sup>2</sup> (trail 1) at a depth of 10 cm and 30 cm respectively.

In the secondary trails with low traffic intensity (trails 5 and 6), penetration resistance was almost the same in ruts as in undisturbed soil (Fig. 5.5). It is not clear whether the sandy character of these trails has led to the stable structure, which was undisturbed by a few passes of the skidder.

Penetrometer measurements were not satisfactory for assessment of soil compaction, as they were influenced by soil moisture content so that a relatively low resistance was found on wet trails. As most measurements on the old skid trails were carried out at field moisture content, close to field capacity (pF 2), which is often the case in rain forests, it is doubtful whether penetration resistance can be used as a reliable strength factor for forest soils. The dominant role of moisture content is demonstrated in the last experiment (trail 7), which investigated the effect of increasing travelling intensity on soil compaction.

Three trail sections of gravimetric field moisture contents of 14%, 20% and 26% respectively were compared after the fifth round trip of the skidder (Fig. 5.6). Penetration strength clearly decreased with increasing moisture content throughout the profile. In the relatively dry section of 10-30 cm below ground level, the penetration strength ranged from 200 to 350 N/cm<sup>2</sup>, and was substantially higher than in the wetter parts.

In spite of the large number of penetrometer measurements taken in the observational units, it was difficult to establish a clear relationship between penetration strength and degree of compaction. Penetration resistance was reduced substantially at moisture contents near to field capacity, especially in sandy clays. However, no relationship was found between other soil factors and penetration

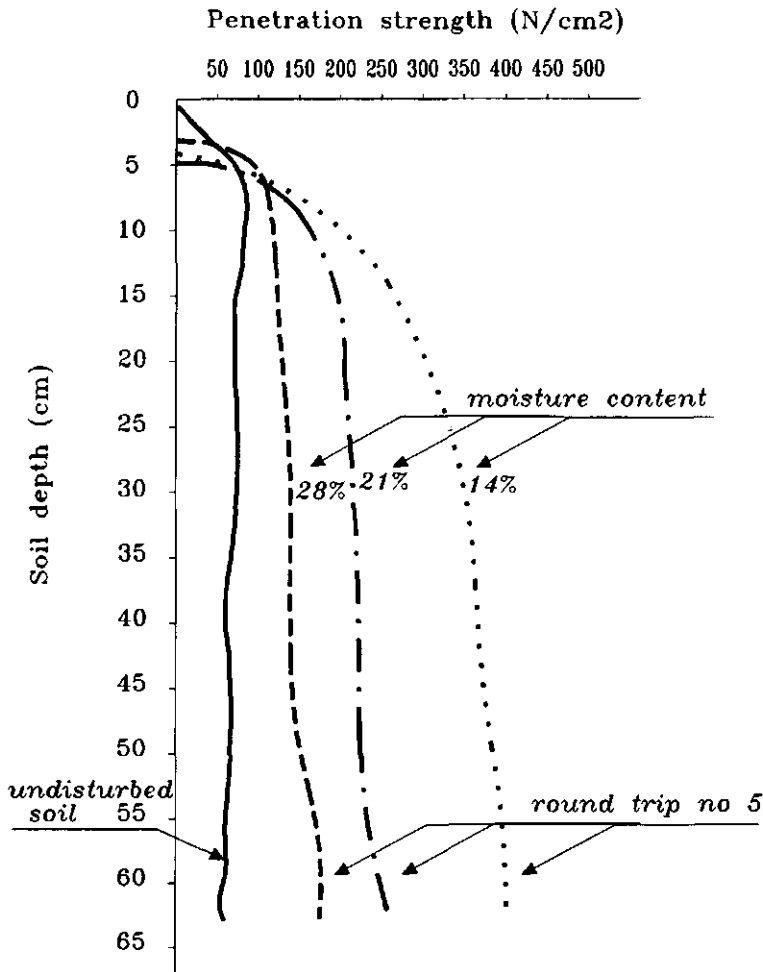


Fig. 5.6 Penetration strength in relation to traffic intensity and moisture content

strength. This parameter can be used in forestry engineering to obtain a quick and reliable indication of terrain trafficability because higher penetration resistance indicates higher soil strength.

## 5.5 Appraisal of soil compaction factors

### 5.5.1 Compaction factors

The many variations in soil factors and properties make comprehensive field

testing both costly and time consuming. More in-depth studies of soil behaviour under loading should be done in laboratory where conditions can be controlled. One well-known test is the standard uni-axial compression to examine soil sinkage under continuous loading (Koolen and Kuipers, 1983). Laboratory methods were used by Beekman (1987) to design models to predict soil behaviour of forest roads and to classify soils according to trafficability and compactability in relation to the use of harvesting machines.

The soil tests in the present study aimed to verify findings in soil mechanics considered relevant for the development of the timber harvesting system envisaged. As means were limited, only simple standard methods were used for quick and practical assessment of soil factors (see Section 3.4). As in previous studies (Miles et al., 1981), moisture content was found to be a dominant factor. Especially on the sandy clays, the properties of which are largely determined by the clay fraction, compaction is a constant risk because of the high moisture content throughout the year. All field tests were carried out at the beginning of the rainy season under conditions favourable for skidding. Nevertheless, soil moisture content was high, often close to field capacity.

The degree of compaction was almost maximal after the fourth round trip and only increased slightly with subsequent trips of the skidder (see Fig. 5.3). Compaction after the first round trip in the stump area was not convincingly related to increased bulk density, but the water infiltration capacity of the topsoil was greatly reduced. This was probably caused by smearing of the soil by the slipping wheels of the skidding machine.

The scope of the study was too limited to assess single effects of strength-determining factors such as density, texture, moisture content and organic matter content on soil qualities, including water retention and conductivity and resistance to root penetration.

Compaction was not found to be clearly related to soil density. One complicating factor was the variation in textural composition of soil profiles, another was the increase of density with depth. This relationship is determined by the weight of the soil particles, exerting a static pressure which can be approximated by the product of soil depth and density at a given point in the soil matrix. A proportional increase in density with soil depth to  $1.50 \text{ g/cm}^3$  was, therefore, expected and is in accordance with previous research (Hartge and Sommer, 1982). Higher values were probably caused by compaction. The highest bulk density of  $1.70 \text{ g/cm}^3$  apparently resulted from intense skidder movement was found in one trail only. In other trails the maximum bulk density was about  $1.60 \text{ g/cm}^3$  and not necessarily related to compaction of the subsoil.

Compaction was easier to determine in the upper soil than in the subsoil of the skid trails. This is because wheel-induced stresses tend to be less in the lower layers of the soil. This can be explained as follows.

The stress distribution in a soil, subjected to evenly distributed vertical stresses acting on a circular area at the soil surface, can be derived from the Boussinesq

solution for point loads (Koolen, 1986). The stresses under the centre of the loaded circular area are the highest; they can be derived as:

$$(\sigma_1)_z = q (1 - \cos^{\nu} (\arctan (r/z))) \quad (5.1)$$

where :

$(\sigma_1)_z$  = maximum normal stress in the soil at depth  $z$  under the centre of the circular area.

$q$  = stress acting at the circular surface area.

$r$  = radius of the surface area.

$\nu$  = concentration factor, which reflects the firmness of the soil;  $\nu = 4$  for normal conditions.

Assuming that the situation at tyre-soil interfaces is similar to an evenly distributed vertical load on a circular area, and that  $\nu = 4$ , the maximum stresses under the centre of a tyre can be calculated with the given formula. Such calculations have been made for the types of skidders used in the present study, that is for wheel loads of 4 and 6 tons (40 and 60 kN) and for tyre pressures of 138 kPa and 172 kPa respectively. The results are given in Fig. 5.7.

The stress level at the contact area (which has been taken twice the tyre inflation pressure to account for tyre carcass stiffness and the ever-existing friction between tyre and soil) is a major determinant of stresses in the upper layers. When considered depths increase, stress levels are determined more and more by the weight of skidder, and are relatively low. Reducing tyre pressure, means reducing stress level in the upper soil and hence risk of compaction. Therefore, for soil protection it is preferable to decrease tyre pressure rather than to reduce payload.

The results of the soil studies are only valid for the dominant soil types in the Forestry Belt of Suriname, although findings are in line with other studies on similar soils (see Froehlich, 1978). A study carried out in the Sierra Nevada forests, California, concluded that soil compaction was determined more by moisture content than by any other variable (Miles et al., 1981). Although soil density increased with the number of trips, much compaction occurred on the first trip. Compaction under the logs was relatively minor. The first two conclusions have been confirmed by the present study. However, no significant difference in compaction was found between the ruts and inter-wheel section of the trail. As a result of frequent movement the rut was wider than tyre width in used primary trails. The inter-wheel section was heavily disturbed and compacted by sliding logs. In the long term, the damaging effect of sliding logs was similar to that of rolling wheels. Used primary trails were evenly compacted over the entire surface.

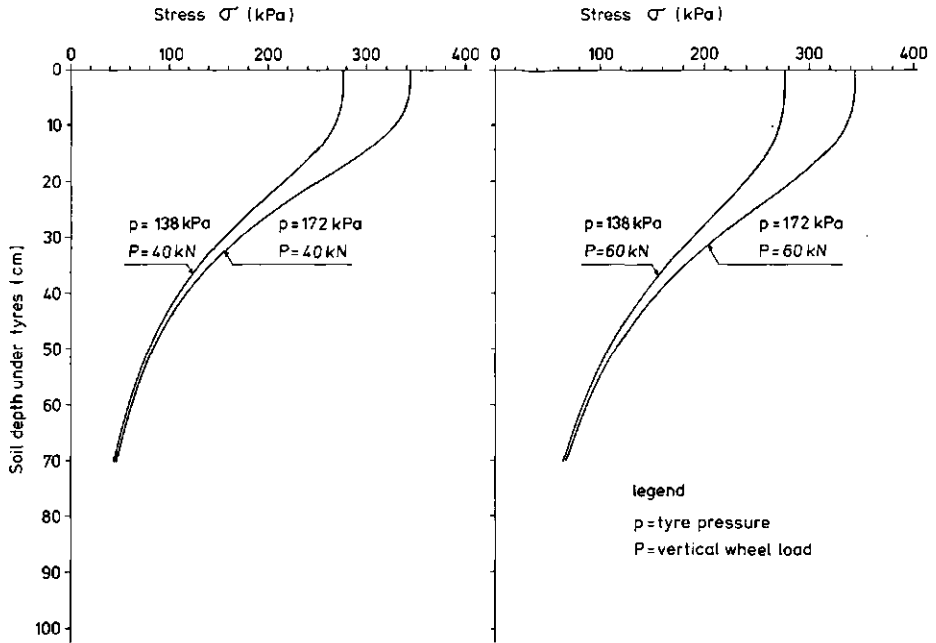


Fig. 5.7 Vertical stress distribution under skidder wheels according to the Boussinesq solution

### 5.5.2 Long-term effects of soil compaction

The long-term effects of soil compaction and disturbance were not investigated in this study. Research in temperate countries indicated that compacted and disturbed forest soils need a period of 20 years or more for soil structure to recover (Hatchell and Rallston, 1971). Froehlich et al. (1981) reported significantly hampered growth of coniferous trees on compacted soil. Other studies report the long lasting effects of reduced aeration and root penetration resistance of compacted soils (Hildebrand, 1983). A long observation period is needed to assess the effects of compaction on tree growth because of variation in site quality and productivity of forest soils, and because of adaptability of trees to changing soil conditions.

The long-term effects of disturbed tropical rain forest soils have not been studied. Surveys carried out in Dipterocarp forests in South-East Asia have expressed concern about detrimental site effects of intensive timber harvesting, without regard to the recuperative ability of the soil (Tinal and Palenewen, 1974; BIOTROP, 1978). There are indications that soil recovery in tropical rain forests is as slow or even slower than in temperate forests (Nicholson, 1979).

The present study covered only one case in which a medium-term effect of soil compaction could be investigated. Skid trails made eight years previously were still in a state of compaction and deformation with no signs of recovery, at least not

with respect to soil density and water conductivity. Primary trails are, therefore, considered to be long-term loss of site productivity. However, there are indications that this is not necessarily the case with secondary trails used for log collection only. These trails were barely distinguishable from the surrounding forest a few years after harvesting. A rapid process of recovery is a possible explanation for this observation.

### *5.5.3 Conclusions*

Findings of the present soil study of relevance to the development of the envisaged harvesting system are summarized below:

- Given the long-term soil damage in primary trails, skidding should be confined to a permanent trail network constructed as part of the infrastructure of a management unit.
- Skidder movements off the trail network should follow the shortest possible connections between stump area and trail in order to restrict compaction and disturbance of the forest floor.
- According to experience of industrialized countries, low-pressure tyres are preferable for both damage restriction and improved trafficability.
- Where possible, primary skid trails should be constructed on well drained sites (water divides) so that rutting is restricted and maximum skidding capacity maintained (also see Section 6.2).
- Harvesting operations should be matched to the seasons; logging compartments susceptible to compaction should not be harvested in the rainy season.

## 6 Logging efficiency

Although designed primarily to increase logging efficiency and to reduce harvesting costs, planning and overall organization may also lead to less logging damage. However, a logging technique developed to control stand damage may be less efficient in terms of production. The major objective of the present study was to assess ways of restricting stand and soil damage during harvesting operations. The harvesting system developed for this purpose was called damage-controlled logging. In Chapters 4 and 5, methods to reduce felling and skidding damage are discussed. The efficiency of damage-controlled logging is considered in this chapter and the implications of this harvesting system are discussed in Chapter 7.

### 6.1 Felling efficiency in conventional and controlled logging

Time and production records were analysed to appraise the impact of the organizational and technical factors on felling efficiency in conventional and controlled logging. Felling production was related to the effective crew time to assess operational efficiency.

#### 6.1.1 Felling production

Time and production records for a period of almost two years were used to calculate the effective crew time and felling production for conventional and controlled logging. Production was assessed to be 31.8 m<sup>3</sup>/day for conventional, 45.9 m<sup>3</sup>/day for controlled, and 47.3 m<sup>3</sup>/day for BSH felling (see Table 6.1). However, in fact, the relationship between production and effective crew time needed to be examined with regard to a number of time conditioning factors as discussed below.

*Felling period (operational time).* Forest operations are carried out throughout the year in Suriname. Felling especially is not restricted to the dry season, but is undertaken regularly in all seasons. The felling period was, therefore, 12 months for each of the three systems studied.

TABLE 6.1. Felling efficiency: summary of time and production records per felling crew, converted to an annual basis

|  | Felling method        |                         |                       |
|--|-----------------------|-------------------------|-----------------------|
|  | Conventional          | Controlled              | BSH                   |
| <b>Time</b>                                |                       |                         |                       |
| operational time (months)                  | 12                    | 12                      | 12                    |
| working days (n/year)                      | 160                   | 193                     | 199                   |
| rain days (n/year)                         | 12                    | 12                      | 10                    |
| other work (n/year)                        | 6                     | 6                       | 22                    |
| delays (n/year)                            | 20                    | 6                       | 5                     |
| effective working days (n/year)            | 122                   | 169                     | 162                   |
| working hours (h/day)                      | 8                     | 8                       | 8                     |
| effective working hours (h/day)            | 3.2                   | 5.6                     | 5.2                   |
| effective crew time (h/year)               | 390                   | 946                     | 842                   |
| man-days (n/year)                          | 320                   | 579                     | 597                   |
| <b>Annual production</b>                   |                       |                         |                       |
| felling area (ha/year)                     | 20 m <sup>3</sup> /ha | 18,6 m <sup>3</sup> /ha | 21 m <sup>3</sup> /ha |
| harvestable volume (m <sup>3</sup> /year)* | 4324                  | 7923                    | 7728                  |
| felled trees (n/year)                      | 1848                  | 3608                    | 3483                  |
| felled volume (m <sup>3</sup> /year)**     | 3876                  | 7757                    | 7663                  |
| felling ratio***                           | 0.90                  | 0.98                    | 0.99                  |
| <b>Production efficiency</b>               |                       |                         |                       |
| per hour (m <sup>3</sup> /h)               | 9.9                   | 8.2                     | 9.1                   |
| per day (m <sup>3</sup> /day)              | 31.8                  | 45.9                    | 47.3                  |
| per ha (m <sup>3</sup> /ha)                | 17.6                  | 18.2                    | 20.8                  |
| felling area per day (ha/day)              | 1.8                   | 2.5                     | 2.3                   |
| man-days per m <sup>3</sup>                | 0.08                  | 0.07                    | 0.08                  |

\* Bole volume of commercial trees >35 cm dbh

\*\* Volume of logs

\*\*\* Felling ratio = felled volume/harvestable volume

**Working days.** The number of working days was converted to a common basis for comparison. The number of days spent in the forest on assigned felling work was taken as working days irrespectively of the wage system used. The usual working cycle in forest exploitation was two weeks, 11 days of which were spent in the forest and three days in the home town. The CELOS crew worked according to this schedule, leaving for the forest on a Monday morning and returning to the city the following week on Friday afternoon. Ten days including one Saturday were available for forest work. Employees of BSH worked from Monday morning to Friday afternoon, but were allowed to leave the forest estate every weekend. The concessionaire's workers were also employed in a fortnight cycle of varying starting days, and with frequent extensions of the period spent in the forest or in the city.



On the basis of 10 working days per fortnight, 30 days vacation and 11 national holidays per year, approximately 220 days were available for forest work. The actual number of working days spent in the forest was lower: 160 days for conventional, 193 days for CELOS, and 199 days for BSH logging (Table 6.1). The large-scale operations of BSH require a stable labour organization, so that a felling crew was always available to work in the two compartments selected for harvest. In case of illness, replacements were always available. This was not the case in the small-scale operations of CELOS, but in general the crew was engaged regularly in tree felling or crosscutting work. Both CELOS and BSH operations were well organized in the sense that felling was done regularly throughout the year without noticeable problems. The annual production was planned on a monthly basis.

The fewer working days in conventional logging was a direct result of the wage system and the planning of felling work. This method of hiring fellers when needed and paying them only for the days worked in the forest is common practice in Suriname. Sometimes fellers have their own power saws and act as a subcontractor, and thus are in a stronger position to negotiate with concessionaires. No attempt was made to keep skilled workers in regular employment and this had an adverse effect on their preparedness to return to the forest for a new period. During the first year of the observation period, the power saw operator was replaced twice by the concessionaire.

*Effective working days.* Fewer effective working days than actual worked days may be considered to be a loss of productive time. However, other work done by the felling crew should not be regarded as lost time but flexibility of organization. Although the three systems differed in organization and management, it was possible to compare efficiency of operations.

The BSH system operated with seven crews, assigned exclusively to felling work. On the Patamacca forest estate, as well as tree felling in the forest, this sometimes included bucking of logs at forest landings after inspection for truck transport, and on the central river landing preparing logs for barge transport. Sorting and crosscutting to plywood and sawmill standards prior to shipping was also part of the BSH logging system. As fellers were employed in all cutting operations, 22 of the 37 non-effective working days per year should not be considered to be lost time, but time spent in other felling activities. Only 10 rain days, and five days of transportation and technical delays were recorded as lost time. This low number of non-productive days was the result of well organized felling operations.

The controlled system differed from the BSH system with respect to organization. Of the 24 days recorded as non-effective, that is not spent on actual felling, six were spent on other harvesting activities. The small-scale operations of CELOS offered few other opportunities although the research purpose required more careful preparations, more accurate measurements and layout work. Delays as a result of technical failure accounted for six days, and rain for a further 12 days. No idle days were recorded. This indicates that small logging operations can also be

organized efficiently, at least with regard to the number of effective working days.

In the conventional system, 12 days were recorded as rain delays, six days for other work and 20 days for delays. The high number of lost days was the result of poor maintenance of the power saw and lack of spare parts or a spare power saw in the forest as well as poor work organization. Maintenance of the engine and the cutting chain were below standard and even spare chains and bars were often not available. The crew lacked supervision and guidance, sometimes having to wait one or two days before the concessionaire arrived with work instructions.

*Working hours.* For comparison, a working day was converted to 8 hours for each system, although, in fact, only CELOS and BSH workers were obliged to work a fixed number of hours per day. The power saw operator hired by the concessionaire could arrange the working time as he wished, provided a minimum of 20 trees per day were felled.

*Effective working hours.* Tree felling is heavy work especially in a hot and humid climate. A break of 30-60 minutes in an eight-hour day was not long enough to recover from the fatigue caused by vibration and noise of a power saw and also from the effects of stem shape and wood density of the trees on sawing perfor-

TABLE 6.2. Felling efficiency: felling cycle and time spent in various operations during a crew time in the forest\*

|                        | Mean time (min) taken in felling method |            |      |
|------------------------|---|------------|------|
|                        | Conventional                            | Controlled | BSH  |
| Felling cycle          |   |            |      |
| tree spotting          | 4.1                                     | 1.2        | 0.9  |
| felling preparations   | 2.0                                     | 4.3        | 3.3  |
| felling                | 1.5                                     | 2.7        | 1.9  |
| bucking                | 0.8                                     | 1.0        | 0.8  |
| measurement            | n.a.**                                  | 1.6        | 1.5  |
| work delays            | 2.1                                     | 1.8        | 1.7  |
| Cycle time             | 10.5                                    | 12.6       | 10.1 |
| Crew time              |   |            |      |
| camp-to-camp time      | 322                                     | 420        | 444  |
| crew's down time       | 55                                      | 42         | 88   |
| power saw service time | 18                                      | 34         | 29   |
| delays                 | 57                                      | 8          | 15   |
| effective crew time    | 192                                     | 336        | 312  |

\* Medians of 183 observations

\*\* Not executed in conventional felling

mance. Frequent rest breaks were needed during the working day, and thus the number of effective working hours was less than eight.

As travel time, technical problems, heavy rain and other factors play a role, a full logging season was required to assess the proportion of time spent effectively in felling work. Only when these figures are known, can avoidable delays be identified as organizational inefficiency.

The effective working hours were computed after eliminating crew's down time, power saw service time, and delays (see Table 6.2). The difference between controlled (5.2 h/day) and BSH (5.6 h/day) logging was small, and was found to be related to the method rather than the performance of the felling crew (see Section 6.1.2).

The low score of 3.2 effective hours per day in conventional felling may be related to the overall organization and also to the working method. The lack of organization is illustrated by the identified time factors such as the high proportion of avoidable delays, amounting to about an hour per working day (see Table 6.1). The practice of felling a fixed minimum number of trees per day also contributed to shorter working days in contract felling as well as to higher risk of felling damage (see Section 6.1.2). In the controlled and BSH systems, the effective working hours were high because of the regular work scheme and preparations made to avoid delays. This indicates that effective working time could be increased to meet the efficiency target of six hours a day (FAO, 1974).

*Effective crew time.* The effective crew time was taken as the number of effective working days per year times number of effective working hours per day; that is 390 h/year for conventional, 946 h/year for controlled and 842 h/year for BSH felling (Table 6.1). The effective crew time related to the annual felled volume identified the conventional method producing 31.8 m<sup>3</sup>/day as less productive than the controlled system producing 45.9 m<sup>3</sup>/day and the BSH producing 47.3 m<sup>3</sup>/day (see Table 6.1). In spite of the high production of 9.9 m<sup>3</sup>/hour in conventional felling, annual production was relatively low due to the low effective crew time resulting from inadequate organization.

Felling efficiency was also indicated by the felling ratio, that is felled volume to harvestable volume. Felling ratios of 0.98 for CELOS and 0.99 for BSH indicate that practically all prospected trees were felled, whereas a felling ratio of 0.90 for the concessionaire indicates that approximately 10% of the harvested trees was overlooked or ignored.

The controlled felling operations were well organized as confirmed by the high effective operational time and, as a result, the high production which differed little from the BSH system. This indicates that the controlled felling system can meet the standards of commercial efficiency.

*Man-days.* The concessionaire used a two-man crew, while CELOS and BSH crews comprised three men: an operator and two assistants who could also operate the

power saw. Yet productivity (man-days per m<sup>3</sup>) was approximately the same: 0.08 for the concessionaire, 0.07 for CELOS, and 0.08 for BSH. Thus leaving aside differences in wage systems, felling cost per m<sup>3</sup> was similar for all three methods. Taking into account quality of the felling work, conventional logging was certainly not less costly than controlled logging. Moreover, the three-man crews of BSH and CELOS were also responsible for inspecting, scaling (measuring) and recording felled trees. When these operations were taken into account, the total felling costs in the controlled systems was definitely lower than in conventional felling. A three-man felling crew was better equipped to perform efficiently and economically, especially under rain forest conditions.

### *6.1.2 Felling methods*

In this section, the relationship between felling method and production per hour is examined in order to determine the efficiency of the felling methods. The study is based on analysis of the time elements of a felling work cycle, that is the total time involved in the first phase of harvesting including tree spotting, felling preparations, actual felling, bucking and measurement (scaling) of logs. A more reliable assessment of efficiency can be made from analysis of the operations in the cycle (see Table 6.2).

*Tree spotting.* In conventional felling, trees were spotted without the aid of a tree location map. A two-man crew was assigned to fell trees in the selected compartments with no information other than a topographic concession map (scale 1:20 000). The power saw operator waited while his assistant searched for a tree. Tree spotting took 39% of the cycle time, that is almost four times as long as in the controlled system (see Table 6.2).

Although it was not easy to appraise individual negative effects of the unsystematic search procedure, it is clear that the lack of terrain and stand data is an unfavourable starting point for efficient felling. The crew did not have an overview of the logging compartment and did not know the sequence in which trees should be felled. There was a tendency to start felling close to the forest road. Tree identification was not a major problem but an extra task for the felling crew. When a commercial tree was found, it was felled, bucked and topped immediately. The search for the next tree began close to the last stump area but was not done systematically. Trees were found and felled one by one. Spotting was hampered by trees felled in the direction of other commercial trees. After each felling, it took several minutes to find the next commercial tree. In poorly stocked parts of the forest especially, it sometimes took more than eight minutes to find harvestable trees of good quality.

In controlled and BSH felling, tree spotting by one of the assistants took only 1.2 and 0.9 minutes respectively (Table 6.2). The time difference is negligible and

probably caused by a difference in skill. The BSH crew had a high production rate and was more experienced than the CELOS research crew. The working method was the same, using a similar type of tree location map. About a minute was required to trace a tree from the map, to check its number and to remove the label (tree number) from the trunk. All activities were concentrated in one inventory unit and felling proceeded in a predetermined direction, that is from west to east and from north to south, as in prospecting.

*Felling preparations.* All preparatory activities after arrival at a spotted tree up to actual felling have been included in felling preparations. Underbrushing and liana cutting directly around the tree and removal of loose or sandy bark at felling height were considered to be minimum measures to be taken by the crew. The time records for felling preparations varied considerably for each system, as different measures were taken for safety, efficiency and damage prevention. Felling preparations were essential in the controlled and BSH method, and account for about 33% of the cycle time compared to only 19% in conventional logging.

This difference is partly explained by workers' attitude to felling work. The concessionaire's crew concentrated on a quick job with little concern for their own safety. Underbrushing, liana cutting and bark screening were done, but in relatively open forest provisions for escape routes were limited to incidental clearing of obstructing vegetation. In dense forest, an escape route was made for rapid withdrawal of the operator. On the whole, safety measures were inadequate, but the crew coped with the situation. The preparatory work was too much for one assistant to carry out adequately alone, but more important was the lack of the skills required for systematic and safe work and the lack of awareness of the risks and dangers of tree felling. The sole objective of the crew was to fell a fixed number of trees, irrespectively of harvesting or damage prevention schemes.

The BSH crew proved to be skillful in many respects and was subjected to a logging scheme based on systematic and orderly felling of inventory units (see Section 3.1.5). The three-man crew took all necessary precautions for safe and efficient felling, and tried to prevent timber damage. Two assistants were sufficient to remove obstacles in the stump area, to cut two escape routes, and occasionally to remove the bark from the tree. Although directional felling was not applied, and skid trails were opened after felling, the felling pattern was less chaotic than in conventional logging because the crew tried to avoid concentrations of felled trees in order to keep the stump area accessible. The crew kept the site as free of obstacles as possible so that all activities including scaling, could be done without unnecessary delay.

In the controlled system, felling was carefully prepared and the same safety measures were taken as in the BSH system, as well as extra measures to influence the felling direction. This comprised liana cutting and inspection of the immediate surrounding of a tree to determine the felling direction. As half of the preparation time was spent on these measures, the felling method had a significant effect on the

cycle time and on overall efficiency. An extra minute per tree was taken on average for these operations compared with the BSH method.

*Felling.* The actual mean felling time in the conventional method was 1.5 min (14% of the cycle time) compared to 2.7 min (21%) for the controlled and 1.9 min (19%) for the BSH method. The conventional system aimed at easy felling to achieve the target of 20 trees a day as quickly as possible. Fellers had developed their own system for quick felling in an unsafe working environment, at the expense of substantial wood wastage (see Section 4.4). The most comfortable position was chosen to get the tree down with a minimum of effort. Fellers started by making the notch (see Fig. 3.2) with a deep undercut approximately one-third of the diameter of the tree and high above the ground (60-120 cm) to speed up the fall. For the same reason, a notch of two oblique cuts was sometimes made. Insufficient time was taken to make a straight and horizontal undercut and back cut, the latter often sawn at a tilt, and therefore, either too low or too high from the notch. The deep notch hindered control of the felling direction.

In the controlled system, felling was executed according to strict harvesting rules, and included a number of operations recommended for safe and efficient felling (Hilf, 1965; FAO, 1980; Conway, 1978). The method itself is described in Section 3.1.1 as a component of the controlled logging system. Discussion here is confined to experience with the method.

As CELOS fellers formerly worked in conventional logging, a long period of training and supervision was required to change workers' attitudes to felling operations and to convince them of the economic, ergonomic and ecological working principles involved. A stump enumeration demonstrated the success of these efforts (see Section 4.4). Emphasis was put on work quality, and high accuracy was attained in cutting the notch and back cut (Fig. 3.2). An essential improvement was the positioning of the felling cut as low as possible, that is approximately 20-40 cm above the ground on trees without buttresses. The use of wedges was made obligatory and most trees could be directed during their fall. Directional felling in a strict sense, that is full control of the felling pattern, was not feasible, however. Often a compromise had to be found between natural lean and the felling direction desired for safety and efficiency reasons (see Section 6.1.3). With an actual felling time of 2.7 min, the controlled method was considered to be efficient as stump losses and other forms of wood waste were reduced, and the skidding pattern was more efficient than in conventional felling.

Felling time was slightly less in the BSH method compared with the controlled method, but the difference was minor, taking into account the extra time required to direct a tree. With the exception of a higher stump loss, other forms of wood waste were as low as in the controlled system. Notch and back cut were sawn properly and the working environment was safe. The felling pattern was different because of the skidding method followed. From the point of view of production efficiency, the BSH felling technique can be considered to be effective and well organized.

*Bucking.* The time taken in bucking a felled tree was minimal: 0.8 min (7.6% of the cycle time) for conventional, 1.0 min (7.9%) for controlled, and 0.8 min (7.9%) for BSH felling. Apparently, crosscutting work in the three felling methods had a similar effect on felling production. However, in the conventional method some wood was lost as a result of wasteful bucking of felled trees. Inadequate crosscutting was frequently observed in conventional felling and was a factor in wood damage (see Section 4.4).

The top of a felled trunk is often under stress and may split if the operator is not vigilant. Under the conventional system splitting occurred because trees were topped without a first cut on the compression side. Fellers seemed to have an incorrect interpretation of the effect of wood under stress. They knew from experience that a sawblade may stick in a tree if the wood is under stress but the implications for crosscutting were not fully understood. Misjudgements were made whether a log was under tension or compression, and accordingly, an incorrect decision made on how to crosscut. Without an upper cut the log may split at the top and thus be rent into two unusable parts. This technique was not applied in the conventional system. Bucking was only done by an undercut or in combination with a very shallow upper cut because wedges were not used and fellers wanted to avoid delays caused by a pinched blade.

Crosscutting in controlled felling included the use of wedges and a careful inspection of the stem for tension prior to topping or bucking. Wood damage was recorded only on a few susceptible species with brittle wood. Bucking was considered to be dangerous (kick back of the tree) and hence undertaken with care.

*Measurements.* In the controlled and BSH system a felled tree was measured, numbered and recorded in the stump area by the felling crew (see Section 3.5). Similar time was recorded for these activities: 1.8 min and 1.7 min respectively. In the conventional system, logs were not scaled in the stump area but on the forest landing after skidding. Log measurement in the stump area allowed for more accurate assessment of felling production and facilitated crosscutting of logs to utility standards

*Work delays.* Rest periods and intermediate maintenance of the power saw are referred to as short delays in the cycle. As these breaks are an essential part of a felling work cycle, they were not considered as avoidable delays. The recorded times were similar in the three systems and hence the effect on felling efficiency was similar.

### 6.1.3 Effects of directional felling

The felling methods applied by CELOS and BSH were based on controlled felling executed by three-man crews and subjected to the same safety regulations (see Section 3.1). Directional felling to restrict harvesting damage was used by CELOS, while BSH system aimed at production efficiency only. The efficiency and safety aspects of directional felling are discussed in this section.

The records of the time and method studies of directional felling are presented in Tables 6.3 and 6.4. In total 362 trees were included in this observation. All trees were felled with the aid of wedges and were forced to fall in a predetermined lay (see Section 3.1.2). In total 288 (80%) of trees were felled according to the predetermined lay, allowing for a deviation of 45° on either side. Less than 11% or 39 trees were felled at an angle of approximately 90° to the lay and only 24 trees (7%) in the opposite direction (see Table 6.3).

*Effect of lean and diameter.* A tree with no significant lean can be felled in any direction. No technique is required other than accurate sawing of a notch to steer the tree. In the controlled system, wedges were used to keep the back cut open and as an extra safety measure. Felling times were approximately the same as in controlled felling (without directing) as the use of wedges took no extra time. The wedges were handled by an assistant, while the operator did his work. About 40% of the trees were felled in this way. The effect of stem diameter on the actual felling time was noticeable. Trees above 70 cm dbh required more labour intensive felling (see Section 6.1.4).

TABLE 6.3. Directional felling: natural lean of trees per diameter class and actual felling direction

| Lean/felling direction          | Number of trees per diameter class (cm dbh) |           |           |           |           |           | Total      |
|---------------------------------|---|-----------|-----------|-----------|-----------|-----------|------------|
|                                 | 40-50                                       | 50-60     | 60-70     | 70-80     | 80-90     | >90       |            |
| <b>Lean before felling</b>      |   |           |           |           |           |           |            |
| without lean                    | 23  | 31        | 28        | 29        | 20        | 16        | 147        |
| 45° deviation                   | 30  | 26        | 14        | 18        | 7         | 9         | 104        |
| 90° deviation                   | 15  | 19        | 16        | 8         | 7         | 8         | 73         |
| 180° deviation                  | 10  | 6         | 8         | 5         | 6         | 3         | 38         |
| <b>Total</b>                    | <b>78</b>                                   | <b>82</b> | <b>66</b> | <b>60</b> | <b>40</b> | <b>36</b> | <b>362</b> |
| <b>Actual felling direction</b> |   |           |           |           |           |           |            |
| according to lay                | 68  | 75        | 60        | 49        | 21        | 15        | 288        |
| 90° from lay                    | 9   | 7         | 2         | 3         | 8         | 10        | 39         |
| 180° from lay                   | 1   | 0         | 2         | 7         | 6         | 8         | 24         |
| undirectable                    | 0   | 0         | 2         | 1         | 5         | 3         | 11         |
| <b>Total</b>                    | <b>78</b>                                   | <b>82</b> | <b>66</b> | <b>60</b> | <b>40</b> | <b>36</b> | <b>362</b> |



TABLE 6.4. Directional felling: mean felling time per diameter class observed in directional felling\*

| Lean           | Mean felling time (min) per diameter class (dbh cm) |       |       |       |       |      |
|----------------|---|-------|-------|-------|-------|------|
|                | 40-50   | 50-60 | 60-70 | 70-80 | 80-90 | >90  |
| Without lean   | 0.8   | 1.5   | 2.2   | 2.8   | 4.0   | 5.3  |
| 45° deviation  | 0.8   | 1.7   | 2.5   | 3.1   | 4.2   | 5.6  |
| 90° deviation  | 1.2   | 1.8   | 2.7   | 3.6   | 4.7   | 6.5  |
| 180° deviation | 1.4   | 2.0   | 3.1   | 4.6   | 6.7   | 10.0 |

\* Medians of 362 observations

Trees with a lean of 30-60° from the desired lay required more time to fell. Felling was done more carefully to direct the tree and wedges were used not only to facilitate sawing but also to steer the fall. Yet the felling time did not differ very much from the former situation because all operations were combined without extra delays. The location of the notch and the shape of the hinge were determined quickly, and sawing proceeded until the back cut was completed. Then the assistant finished the job by hammering the wedges further in the back cut. The steering effects of wedges decreased for trees of more than 80 cm dbh (Table 6.3).

Trees with a lean of more than 90° from the desired direction were difficult to fell. Lean and lay had to be matched to determine the location of the notch and the amount of holding wood. Coordination between operator and assistant took more time, and sawing stopped frequently to facilitate wedging and to reconsider safety. Trees above 90 cm dbh were very difficult to steer and required, depending on their lean, up to 10 min to fell (Table 6.4) under unsafe working conditions. The risk of kick back or splitting of the tree in the direction opposite to the lean increased and also the work load. There were 39 trees (11%; see Table 6.3) in this category of which about half (20 trees) could be felled according to the lay; the remaining trees were all more than 70 cm dbh.

Some trees had to be felled in the opposite direction to their lean, that is trees with 180° deviation. Felling time increased substantially with increase in diameter to 3.6 and 4.7 min at 70 to 80 cm dbh respectively (Table 6.4). Only smaller trees could be felled safely against their lean without substantial delay. The wood of trees of this category is under compression at the side of the lean and under tension at the opposite side, thus creating an extra problem when the notch and back cut were made. Care had to be taken to make the notch not too deep, and to prevent splitting of the trunk. Making the back cut was even more difficult as there is constant risk of pinching of the saw bar. More than 50% of the felling time was spent on wedging and coordination. Sawing was stopped frequently to change the cutting procedure. In total 11 trees, recorded as 'undirectable', had to be felled according to their lean (Table 6.3).

Generally, only trees up to a diameter of 60 cm could be felled against their lean, in the sense that the lay could be modified but not changed completely. Larger trees could not be manipulated much but had to be felled in accordance with their natural lean.

*Safety and work load.* Two aspects of safety have already been mentioned: risk of kick back and danger of a heavy work load. For trees of less than 60 cm dbh, directional felling using wedges and felling levers is effective and safe. However, this method is dangerous if trees are very large in diameter or have too much of a lean to be directed in their fall. When larger trees are felled against their lean, counter forces which in excess of tens of tons may have to be overcome. A heavy hammer is then required to insert wedges in the back cut. This heavy and time consuming work results in fatigue which might affect the alertness of workers. For safety reasons it is recommended that trees over 60 cm dbh are not be directed more than 90° against their lean.

Trees with buttresses are difficult to fell even when not directed. Special care should be taken when the desired lay differs very much from the head lean. From the point of view of safety, buttressed trees should preferably be felled towards, or not more than 45° from the head lean.

#### *6.1.4 Other conditioning factors*

As discussed previously (Sections 6.1.1 and 6.1.2), felling efficiency was largely determined by organizational factors and, to a lesser extent, by the working method. It is also influenced by terrain and stand features. Working on slopes in hilly and mountainous terrain requires more safety precautions and measures to prevent felling damage than when working on flat or undulating terrain. Ground roughness, severe underbrush and other obstacles are also factors which may affect production. Stand factors to consider are density and diameter distribution of harvestable commercial trees. In this section the influence of tree characteristics such as buttresses, diameter and wood density are discussed for the forest under consideration.

*Buttresses.* Depending on the number and dimensions of the buttresses, actual felling time was up to three times that for trees without buttresses of the same dbh. Yet, the presence of buttresses had little impact on daily production. Firstly, 12% or less of the felled trees had significant buttresses, and these trees were distributed throughout the experimental compartments. Secondly, use of a power saw in combination with proper felling techniques did not necessitate building a platform above the buttresses. Consequently, the presence of buttresses raised the average length of a working cycle by two to four minutes only.

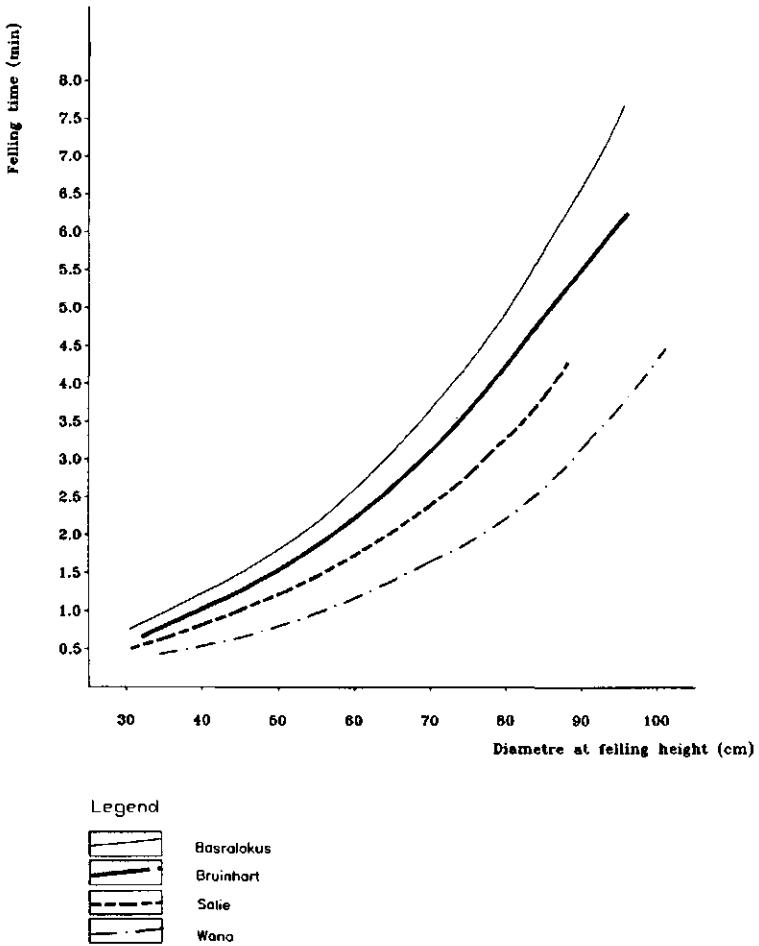


Fig. 6.1 Relationship between trunk diameter and felling time for four commercial timber species

**Wood density and tree diameter.** The effect of tree diameter and wood density on felling time was tested on four species: basralokus, bruinhart, sali and wana. The data are presented by fitted lines with diameter on felling height as independent variable, felling time as ordinate and species (wood density) as parameter (see Fig. 6.1). Four 'sawing classes', to match specific densities of  $0.66 \text{ g/cm}^3$  (wana),  $0.78 \text{ g/cm}^3$  (sali),  $0.90 \text{ g/cm}^3$  (basralokus) and  $1.05 \text{ g/cm}^3$  (bruinhart), were distinguished. They are related not only to the specific density but also to other properties of the wood, such as silica and gum or resin content, which is demonstrated by a timber as basralokus. In spite of its lower wood density, the latter is more difficult to saw than bruinhart.

The presented graph is meant to show the influence of the conditioning factors

rather than as a standard for actual felling times. There was a linear increase in felling time with increasing tree diameter up to approximately 50 cm dbh. With larger diameters, the increase became exponential. This change, starting between 50 and 60 cm dbh, coincided with the effective cutting length of the bar of the power saw. This meant that the operator had to change position during felling and that more power was required to drive the bar completely into the solid wood mass.

The timber species presented in Figure 6.1 were identified as being dominant in the three research areas (see Section 4.1): sali (*Tetragastris altissima*) in the conventional, bruinhart (*Vouacapoua americana*) in the controlled and basralokus (*Dicorynia guianensis*) in the BSH experimental compartments. However, they represent less than 10% of the total harvested stock and were apparently not decisive in felling production.

In all experimental compartments the diameter distribution was similar with a mean value of approximately 55 cm dbh (also see Table 3.5). As many as 85% of the observed felled trees were in the diameter class 45-70 cm dbh. Felling time varied from 1.6 min for the 'easy' trees to 3.7 min for the 'difficult' ones. As already explained, such differences, although not negligible, had no significant effect on felling production, given the fact that a proportionally higher volume is harvested when large trees are felled.

## 6.2 Skidding efficiency in conventional and controlled logging

In mechanized skidding, the effective operational time is the effective machine time and, together with terrain and stand factors, determines skidding efficiency to a large extent (Conway, 1982). Skidding operations need to be well organized to make effective use of the available machine and labour capacity. While felling costs are remarkably uniform for different types of rain forests and terrain classes, skidding cost are affected substantially by terrain features and by transport distances (Sundberg and Silversides, 1988; 1989). Control of skidding cost should, therefore, be a main concern in every logging operation.

In this section, the skidding efficiency of the controlled logging system is compared with conventional logging. The BSH skidding method differed too much for direct comparison with the controlled and the conventional methods and therefore is discussed separately in Section 6.4.

### 6.2.1 Skidding production

Skidding records were systematically collected over a period of approximately two years. Production and time records were converted to an annual basis to simulate a year of regular logging operations, thus eliminating seasonal influences. This approach was used to assess organizational and technical factors.

Annual skidding production was calculated to be 3461 m<sup>3</sup> and 6086 m<sup>3</sup> and daily production 28.6 m<sup>3</sup>/day and 37.8 m<sup>3</sup>/day for the concessionaire and CELOS respectively. This difference in production efficiency is also expressed by comparing the two methods on basis of man-days per m<sup>3</sup> and machine hours per m<sup>3</sup> (see Table 6.5).

Effective machine time, calculated from effective working days and machine hours per day, was used as a basis to compare the two skidding methods (see Table 6.5). In conventional skidding, the number of effective working days was just 121 per year because of maintenance and repair to the skidder, and work other than skidding. The remaining 46 working days included 19 days for repair and maintenance, 6 days of no work because of rain, and 21 days for loading a truck and sorting logs on the forest landing. For controlled skidding, a 161 effective working days were recorded, and only 7 days were registered for incidental repairs and

TABLE 6.5. Skidding efficiency: summary of time and production records for conventional and controlled harvesting

| Record                            | Skidding methods |            |
|-----------------------------------|------------------|------------|
|                                   | Conventional     | Controlled |
| <b>Time</b>                       |                  |            |
| operational time (months/year)    | 12               | 12         |
| working days (n/year)             | 167              | 172        |
| rain days (n/year)                | 6                | 4          |
| repairs (n/year)                  | 19               | 7          |
| other work (n/year)               | 21               | 0          |
| effective working days (n/year)   | 121              | 161        |
| effective machine hours (h/day)   | 5.3              | 6.0        |
| effective machine time (h/year)   | 641              | 966        |
| man-days (n/year)*                | 334              | 344        |
| available machine time (h/year)** | 1336             | 1376       |
| <b>Annual production</b>          |                  |            |
| skidded area (ha)                 | 220              | 322        |
| skidded logs (n)                  | 1648             | 2754       |
| skidded volume (m <sup>3</sup> )  | 3461             | 6086       |
| <b>Production-efficiency</b>      |                  |            |
| per hour (m <sup>3</sup> /h)      | 5.4              | 6.3        |
| per day (m <sup>3</sup> /day)     | 28.6             | 37.8       |
| per ha (m <sup>3</sup> /ha)       | 15.7             | 18.9       |
| skidded area per day (ha/day)     | 1.8              | 2.0        |
| man-days per m <sup>3</sup>       | 0.10             | 0.06       |
| machine hours per m <sup>3</sup>  | 0.39             | 0.23       |

\* For a two-man crew

\*\* For an eight-hours working day

periodical maintenance, and 4 for rain delays. The CELOS machine was confined to skidding work only.

In conventional logging, the wheeled skidder was frequently used for other logging activities in small-scale operations. In a strict sense, such work should not be considered as unproductive. The days for repair and maintenance, however, were a direct loss of productive time, as these delays could have been avoided by preventive maintenance. However, giving the poorly organized landing operations in conventional logging and the fact that the skidder was not designed for loading work, of the 21 days of non-skidding work only 10 days could be regarded as effective working days comparable with skidding. Even if this was taken into account, the additional annual production in conventional skidding would have been no more than 286 m<sup>3</sup> (8.2% increase) and still 61% of that of the controlled method.

Although timber harvesting is an all-season business in Suriname, terrain transport is reduced to some extent in periods of heavy rain. These periods can be used to upgrade machinery for more intensive use in the drier seasons. However, this was not common practice in conventional logging. Of the three skidders used by the concessionaire, only one machine was found to be in a reasonable technical state. Frequent repairs were necessary to keep the machines in operating conditions.

In controlled logging, the skidding method appeared to be more efficient than the conventional method (see Table 6.5). Although derived from an experimental situation, figures showed a clear relationship between the effective operational time (that is effective machine time) and the skidding production in a year. Skidding production with the controlled method was substantially higher than with the conventional method, which is in accordance with the related effective operational time.

When terrain and stand factors are excluded, differences in skidding production can be explained in terms of organizational and technical factors. Although these factors are interrelated and directly influence effective machine time, conventional skidding suffered greatly from technical problems with machinery. The low efficiency of conventional skidding was caused by inferior equipment and lack of attention given to organizational aspects. But further analysis of the time and production records showed that lack of operational planning was also a reason for the extremely low production (see Section 6.2.2).

### *6.2.2 Impact of skidding methods*

For a first appraisal of the efficiency of the working method, the number of effective machine hours (operational time) per day was used. The other parameter, the round trip time (cycle time) to skid a load, was computed from the recorded

time elements. Both time factors were then used to assess the efficiency of the skidding methods.

Effective machine time was computed to be 5.3 hours/day for the conventional and 6.0 hours/day for the controlled method (see Table 6.5). As already discussed, the total effective machine time was a combination of technical and organizational factors, while the difference in effective hours per day (controlled 13% higher) was largely determined by the technical quality of the skidders. The round trip time, however, was subjected to a more complicated relationship with relevant conditioning factors.

*Round trip time.* Two compartments in the northern research area of similar terrain and stand conditions were used for the first skidding tests (see Section 3.5). The same type of wheeled skidders was used to compare the controlled and conventional methods. The time elements were calculated for a skidding distance of 800 m and a payload of approximately 4 tonnes. A round trip or skidding cycle was formulated as the time required to travel from the landing to the stump area, to collect a load, and to return to the landing. A skidding cycle was thus composed of a number of operations which were executed in a fixed sequence. The round trip time consists of a relatively fixed component, that is the time needed to collect the load and to unload a skidder, and a variable component, that is the travel time of the skidder.

The travel time of the unloaded skidder from the forest to the landing was mainly determined by the rated capacity (kW) of the machine and the length and quality of the skid trail. Theoretically, a top speed of 25 km/h in the third gear was possible, but this speed was only achieved by an unloaded skidder travelling on flat paved roads or on forest roads stabilized with gravel. On skid trails of good quality, the top speed does not exceed 15 km/h (FAO, 1977b; Caterpillar, 1986). On the basis of the recorded travelling times of 9.4 min and 7.8 min for the conventional and CELOS methods respectively for a distance of 800 m (Table 6.6), corresponding average speeds of 5.1 km/h and 6.2 km/h were computed for unloaded machines. This should be considered as moderate for the terrain class in the experimental area (see Section 6.2.3). As the skid trails were of similar quality in both compartments and as the same type of skidder was used, the difference in speed may be attributed to the technical condition of the machines. Operator's skill was assumed to be of minor importance in this respect because both operators had received the same training.

The return trip of the loaded skidder took 16.0 min (conventional) and 14.3 min (controlled) respectively. As the same trails were used, but in the opposite direction, there was no reason to assume that the difference in travel time was influenced by factors other than those mentioned above.

The fixed time (the sum of manoeuvre, hooking and unhooking, decking, and idle times), 10.2 min for controlled and 15.4 min for conventional skidding (see Table 6.6), differed substantially between the two methods. This difference

TABLE 6.6. Skidding efficiency: working time (min) of a skidding crew and roundtrip time (min) of a skidder for a standard load of four tonnes and a skidding distance of 800 m\*

| Time elements     | Mean time (min) taken in skidding methods |            |
|-------------------|---|------------|
|                   | Conventional                              | Controlled |
| Skidding cycle    |   |            |
| return            | 9.4                                       | 7.8        |
| collecting        | 5.2                                       | 2.8        |
| hooking           | 3.3                                       | 2.1        |
| unhooking         | 1.0                                       | 1.0        |
| decking           | 1.8                                       | 2.0        |
| delays            | 4.1                                       | 2.3        |
| skidding          | 16.0                                      | 14.3       |
| Roundtrip         | 40.8                                      | 32.3       |
| Crew time         |   |            |
| camp-to-camp      | 460                                       | 420        |
| crew's down       | 49  | 36         |
| machine service   | 62  | 16         |
| delays            | 31  | 8          |
| effective machine | 318                                       | 360        |

\* Medians of 151 observations

(5.2 min) marked the greater efficiency of the controlled method with respect to collecting and presorting of logs. The observed operations are described below to demonstrate how simple organization saved time and increased production.

*Collecting time.* In the conventional method, the skidder was guided by an assistant to the nearest log in the stump area. As most logs were randomly felled, they had to be repositioned for skidding. The blade of the skidder was used to push the log in the required direction. This time consuming and damaging operation took 5.2 min on the average (Table 6.6). After positioning, the skidder was turned and driven backwards to the rear end of the log to connect the winch line directly to the bud. Hooking time took 3.3 min. Then the log was skidded towards the nearest trail and unhooked (1.0 min). When the skidder had to return to the stump area for another log, the collecting procedure was repeated, and logs were combined to one load and skidded to the landing.

The weak points of this working method were the unknown positions of logs after felling, unsystematic search for logs without a tree location map and the direct connection of logs to the winch line. Although the search for other logs started during the return trip of the loaded skidder, the assistant had no overview of the stump areas and was not able to guide the operator along the shortest route. Consequently, delays in a skidding cycle accounted for 4.1 min (Table 6.6).

The controlled method overcame the collection problems by using a tree location



map and by prechoking logs during a return trip (see Section 3.1.3). The working environment in this method was safer and more comfortable because logs were well positioned by controlled felling. Logs could be extracted in an orderly and systematic way by harvesting a compartment from the rear boundary to the landing, leaving the obstructing debris behind. Therefore manoeuvre time (2.8 min), hooking time (2.1 min) and delays (2.3 min) were substantially less than in the conventional method (Table 6.6).

To examine the impact of the controlled method itself, other factors were eliminated as much as possible. The effect of the trail system on skidding performance was examined separately (Section 6.2.3).

### *6.2.3 Effect of the trail system*

Design and construction of a skid trail network prior to felling is a feature of the controlled method, whereas trails were opened by the skidder after felling in the conventional method (see Section 3.1). The positive effect of a planned skidding system on damage restriction is discussed in Chapter 4. The relevance of trail standard, skidding distance and payload to skidding production are examined in this section.

*Trail standard.* Conventional skidding is a type of non-trail skidding (FAO, 1974) and generally the method used in forest exploitation in Suriname. It is practised by all small logging enterprises which cannot afford crawler tractors for trail construction. The wheeled skidder is used to open trails, although not specifically designed for this purpose. The hydraulically operated dozer blade of a skidder is an accessory to bunch logs and to remove obstacles (for instance, underbrush and dead wood) which may hamper movement, but not to push trees down or to clear forest vegetation. When using the skidder for trail construction, the operator tries to find the easiest way through the forest vegetation avoiding big trees and removing only undergrowth and pole-size trees with the dozer blade.

Observations of conventional skidding showed that the first passage of a skidder, moving from landing to stump area, resulted in a narrow track, partly covered with small vegetation surviving the machine's impact. The skidder penetrated the forest along parts poorly stocked in the vegetation to avoid dozing as much as possible. The humus layer was not removed or visibly disturbed, and only obstructing trees below 20 cm dbh were uprooted. Although the operator did not use a topographic map, he tried to locate the main trail on firm and high ground, but inevitably the sites most suitable for trail construction were often overlooked. The first trail thus opened, ended in an area where a number of logs were felled and where skidding started. The first logs were transported one by one as a heavier load could not be skidded along the freshly opened trail, still blocked by many obstacles. Frequent stops to clear the trail were necessary until the fourth trip. After that

the operator considered the trail to be ready for heavier loads. When skidding continued the topsoil was smeared and compacted as a result of the slipping wheels and sliding logs. The final width of the trail was approximately 3.0 m. As skidding proceeded, the main trail was extended to the boundaries of the logging compartment. The result of unplanned trail opening was, as mentioned previously, an irregular network.

The controlled method comprised establishing of the carefully planned and aligned skid trail system. Trails were underbrushed with manual tools and then cleared with a wheeled skidder (see Section 3.1.3). A regular and efficient network of trails was obtained. Skidding efficiency could be increased by reduced length and improved trafficability of skid trails (see Section 4.3). Thus measures to control damage had also favoured production.

*Skidding distance.* The skidding distance is the most relevant variable determining production. The density of a trail network is derived from spacing of access (truck) roads and from the maximum allowable skidding distance. When the skid trail system is planned, its density should be calculated by minimizing the sum of road construction and skidding cost (see Section 7.1.6). Widely spaced roads will lead to high round trip times and hence to high skidding cost, but to lower road building cost.

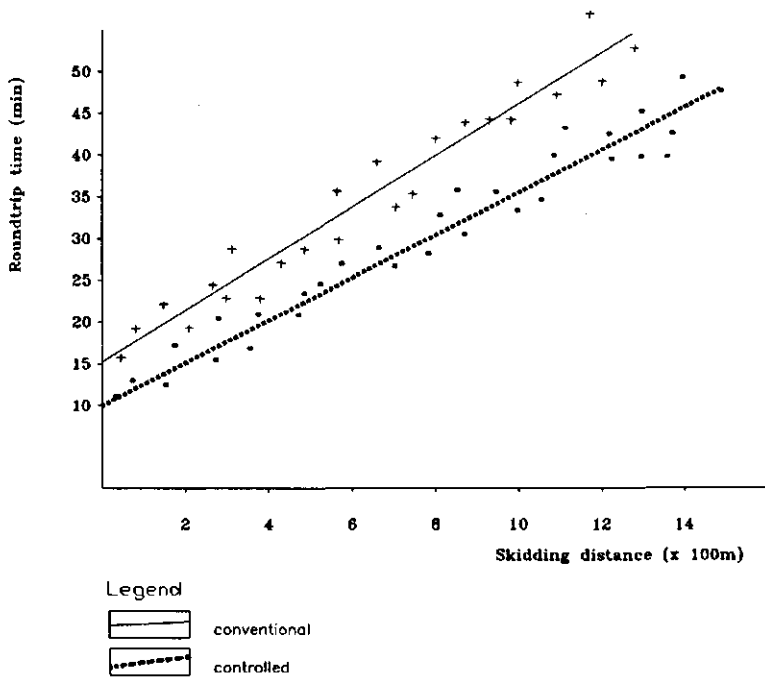


Fig. 6.2 Relationship between skidding distance, roundtrip time, and logging method

The relationship between the skidding distance and round trip time was examined for a standard load of 4 tonnes (see Fig. 6.2). The difference in roundtrip time between the two logging systems presented can be explained in terms of fixed and variable time components:

- fixed time (sum of non-travel time) in conventional skidding (15.4 min) was 51% higher than controlled skidding (10.2 min) (see Table 6.6 and Fig. 6.3);
- travelling speed of the unloaded skidders was assessed to be 85.1 m/min or 5.1 km/h (conventional) and 103 m/min or 6.2 km/h (controlled);
- travelling speed on the return trip of a loaded skidder was 50 m/min or 3.0 km/h (conventional) and 55.9 m/min or 3.4 km/h (controlled).

The lower travelling speed in conventional skidding has been explained by the technical state of the skidder (Section 6.2.2) and the quality of the trail system. In addition to the lower travelling speed, the approximately 40% higher average skidding distance compared with the controlled method (see Section 4.3) also affected productivity. This average distance differed significantly from the target economic skidding distance of 400–800 m (FAO, 1977b).

*Payload.* The effective payload of a skidder is determined by technical and terrain factors. The relationship can be described by the following empirical formula (FAO, 1977b):

$$P = \frac{CT(RP - CR.TW)}{CS + CT.CR.PP} \quad (6.1)$$

where:

- P = payload (kg)
- CT = coefficient of traction
- CR = coefficient of rolling resistance
- CS = coefficient of skidding
- RP = rimpull of the skidder (kg)
- TW = (tare) weight of the skidder (kg)
- PP = percentage of payload weight transferred to the skidder

Reference is made to manuals for an explanation of the equation and the calculation of the payloads for different terrain conditions (Caterpillar, 1986; Sundberg and Silversides, 1989). Based on such calculations, the theoretical payload of the skidders used was computed to be 4.52 tonnes. For the technical specifications of the skidder, see Table 3.2 and Appendix VI.

To determine the optimal payload under varying terrain conditions, in this case varying terrain resistance factors, the rimpull required to skid a load was computed. For each of the standard loads, the required rimpull was derived from the

TABLE 6.7. Skidding efficiency: usable pull (kg) and resistance forces (kg) in relation to payload and slope

| Resistance factor | Slope (%) | Resistance force (kg) in relation to payload (kg) |      |      |      |
|-------------------|-----------|---|------|------|------|
|                   |           | 2000  | 4000 | 6000 | 8000 |
| Grade             | 4         | 450   | 490  | 530  | 570  |
|                   | 8         | 900   | 980  | 1060 | 1140 |
|                   | 12        | 1350  | 1590 | 1590 | 1710 |
|                   | 20        | 2250  | 2450 | 2650 | 2850 |
| Skidding          | 4         | 739   | 1410 | 2117 | 2822 |
|                   | 8         | 860   | 1602 | 2404 | 3204 |
|                   | 12        | 981   | 1792 | 2690 | 3586 |
|                   | 20        | 1224  | 2172 | 3264 | 4350 |
| Rolling*          | n.a.      | 1238  | 1348 | 1457 | 1567 |
| Total             | 4         | 2427  | 3248 | 4104 | 4959 |
|                   | 8         | 2998  | 3930 | 4921 | 5911 |
|                   | 12        | 3569  | 4730 | 5737 | 6863 |
|                   | 20        | 4712  | 5970 | 7371 | 8767 |
| Usable pull       | n.a.      | 6190  | 6740 | 7290 | 7840 |

\* At 15 cm tyre penetration

total resistance force on different terrain slopes. Subsequently, the travelling speed was read from a rimpull-speed graph (see Fig. VI.1; Appendix VI). The results are presented in Table 6.7.

The theoretical travel speed for a four tonnes load at a grade of 8% is approximately 5 km/h, which is higher than actual speeds of 3.0 km/h and 3.4 km/h. A possible explanation is that tyre penetration should not be regarded as a constant factor (as has been assumed for the construction of Table 6.7), but as a variable related to soil strength. Furthermore, travel speed is also determined by operator's skill especially when driving on rutted trails. In other words, the figures in Table 6.7 differ from practical situations and should be considered as minimal resistance forces that need to be corrected for terrain conditions.

The skidding experiments demonstrated that an average standard load of approximately four tonnes was convenient to handle for the CELOS skidder, but in terms of efficiency a load of five tonnes was closer to the optimum. This means that the calculated payload of 4.52 tonnes was a good estimate of the actual payload. A load of five tonnes would reduce the speed by 15% (see Fig. 6.3), but would give a higher production, because collecting and return times remain the same and hence the roundtrip time is increased by less than 15%. In conventional

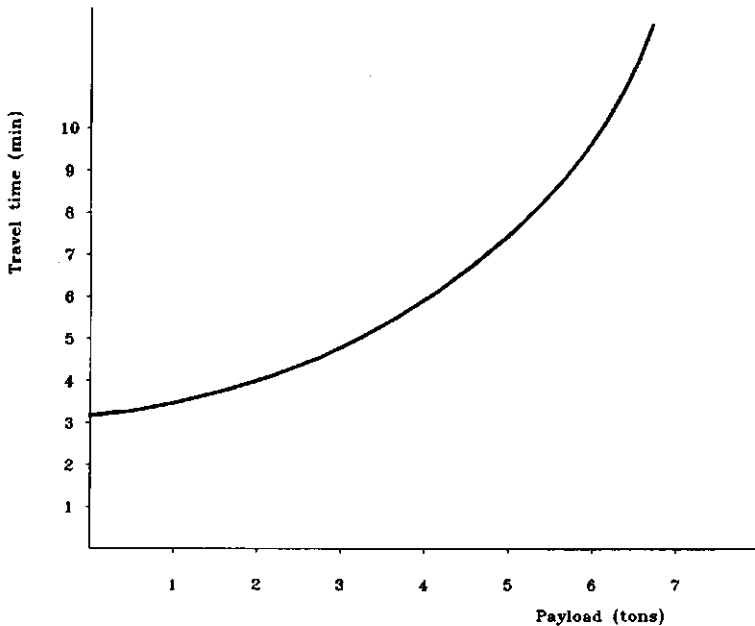


Fig. 6.3 Relationship between payload and skidder travel time for a distance of 800 m

logging the payload of four tonnes was almost the maximum the skidder could transport without problems. Heavier loads could be skidded only occasionally over short distances on firm trail sections.

### 6.3 Winching efficiency in controlled logging

Winching logs from the stump to the skid trail aimed at preventing skidding damage (see Section 3.1.4). This method proved to be less damaging than preskidding of logs (Section 4.3). In this section basic working and time elements of the method are analysed and the efficiency of the winching technique examined.

#### 6.3.1 Winch technique

Two time studies were conducted to examine the winching technique (see Section 3.5.2). In the first study, the technique was tested with a standard equipped skidder and feasibility examined for tropical rain forest conditions. The second study investigated the effects of a number of factors including operator's skill, log dimensions and, to a lesser extent, terrain and stand factors.

The following operations of a winching cycle were observed:

- pulling out the winch line;
- setting the chokers to the logs;
- hooking the winch line to the chokers;
- winching the log to the trail;
- unhooking the winch line;
- decking the log.

For a standard load of 4 tonnes transported a distance of 20-30 m the cycle time was assessed to be 6 min, corresponding with a theoretical production of 40 m<sup>3</sup>/h (see Table 6.8). Real production was derived from the time records of the operations.

*Pulling out the winch line.* A 19 mm diameter line is standard for logging operations in Suriname and preferred by concessionaires for the greater strength than the 16 mm line recommended in the technical specification for the machine (Caterpillar, 1986). This is a malpractice because rough and careless skidding occurs with an overdimensioned cable, with the risk of overloading the winch components.

A winch line of 16 mm thickness was tested. In addition to weight reduction, the thinner cable appeared to be more flexible for winding on the winch drum without frequent jamming. Furthermore, this line could be pulled out by one assistant only, making job rotation within the working cycle possible. It should be possible for one man to pull out a winch line of proper specification with moderate effort at walking speed. Generally a minute was sufficient to reach a log within a distance of 40 m. At greater distance the line became heavier and considerable force was required to pull it out (see Section 6.3.2).

TABLE 6.8. Winching efficiency: cycle time for pulling out a winch line and winching in a load of four tonnes\*

| Time elements        | Mean cycle time (min) for winching distance (m) |       |
|----------------------|---|-------|
|                      | 20-30   | 30-50 |
| Winching cycle       |   |       |
| pulling out the line | 0.8   | 1.1   |
| choking              | 1.1   | 1.2   |
| hooking              | 0.5   | 0.5   |
| winching             | 1.2   | 1.9   |
| unhooking            | 0.5   | 0.5   |
| decking              | 0.9   | 0.8   |
| delays               | 1.0   | 1.1   |
| Cycle time           | 6.0   | 7.1   |

\* Medians of 191 observations

Unwinding a line of 19 mm thickness from the winch drum was a tough job, which had to be done by two men when a distance of 15 m was exceeded. The time required to pull the line 30 m to the stump varied from 0.5 to 1.0 min. Two assistants constantly occupied with this activity experienced fatigue after a few winching cycles. This problem was solved when a winch line of 16 mm was used, thus reducing the weight from 0.70 kg/m to 0.48 kg per metre cable.

*Setting the chokers.* Different types of chokers were tested on operational efficiency. The most suitable type was found to be the choker with patent bell and double nubbin, which allows rapid connection to the log and winch line (see Fig. 3.8). Choker length was 4-6 m and diameter 16 mm.

As logs were winched one by one, a set of four to six chokers was convenient. Occasionally, two small logs could be winched in one work cycle. While one assistant followed a log during winching, the second worker set another choker thus saving time. After some training, this technique could be used without time delay. Setting time ranged from 1.0 to 1.5 min per log, depending on size and location of the log.

*Hooking.* Two techniques to connect the winch line to the choker were tested. In one technique a winch line was used with a hook at the end, in combination with chokers with pressed eyes (Fig. 3.8). In the other, a line with a nubbin on the end was used with double-nubbin chokers. The latter was preferred as a cable without the extra weight of a bull hook (approximately 3.5 kg) is more convenient to handle. Hooking time was almost negligible, not more than 0.5 min.

*Winching.* The essential element of a winching cycle is pulling a log over the forest floor towards the skidder. Many obstacles can block a moving log, causing a 'hang-up'. Whenever this happened, the assistant had to signal the operator to slacken the winch line. The choker was then reset so that the log could roll or slide away from the obstacle. Workers were able to release logs from obstacles simply without using tools other than cutlasses and chokers.

Large trees and stumps were the most important obstacles, while ground roughness and slope only caused troubles when very heavy logs (exceeding five tons) were winched. Approximately half of the winching time was spent guiding the moving log or changing its direction. The rated speed of the winch line of 60 m/min (walking speed) could only be achieved for very short distances. In theory, one minute should be sufficient to winch a log a distance of 50 m to the trail, but in practice this operation required several minutes.

Observations made to identify the factors controlling efficient winching led to the following conclusions:

- Felling pattern is important for smooth movement of logs towards the trail. Perfect directional felling aiming at a lay of 30-45° with the skidding direction

may create the most favourable pattern. It was observed that the lay of logs could be easily corrected by resetting the chokers several times if necessary. The most difficult logs to position were those close to the trails, at an angle of about 90° to the skidding direction. Logs away from or parallel to the trail were easier to manoeuvre. Typical lays identified in this study are presented in Fig. 4.10.

- The skill of the crew was an important factor. Substantial improvement was observed between the first winching experiment (van Leersum, 1984a; Oestersholt, 1986) and the subsequent trials. The felling crew made a better felling pattern, and hence improved the starting position for winching, and the skidding crew developed better techniques in releasing hang-ups. Communication between operator and setters was better and winching time was reduced (see Section 6.3.2). The method finally developed is recommended as a basic component for damage-controlled logging.
- In addition to workers' skill, log dimensions and skidding distance were identified as conditioning factors.

The relationship of these factors to the cycle time, is discussed in the following section.

*Unhooking.* When a log arrived at the trail, the winch line was slackened and unhooked (or unlocked) by the setter who had guided the log. Unhooking took 0.5 min. No special problems were observed in this stage of the working cycle.

*Decking.* The last action was the positioning and grouping of logs along the skid trail for further transport to the landing. When a log was winched from a favourable lay, further handling was often not necessary. For a log lying at more than 45° to the trail, the skidder had to manoeuvre the log until it was in a transport position. Sometimes the log was dozered by the skidder to the edge of the trail. Decking in the strict sense, that is piling of logs to save space and to facilitate loading, was only done when necessary.

### *6.3.2 Effect of winching distance, cable weight, and log size*

*Winching distance.* A winching cycle consists of (relatively) fixed and variable time elements. The fixed time elements are for choker setting, and hooking and unhooking to the winch line. Time for pulling the line out and winching the load varied with winching distance and terrain condition. The effect of distance on cycle time was investigated for three situations: for winch lines of 30 m × 19 mm and 70 m × 16 mm respectively and for two log lengths (see Section 3.5).

The results are presented in Fig. 6.4. There was little difference between the fixed times of the second (1.5 min) and third experiments. The comparatively high fixed time of 3.1 min recorded in the first experiment may have been influenced by lack



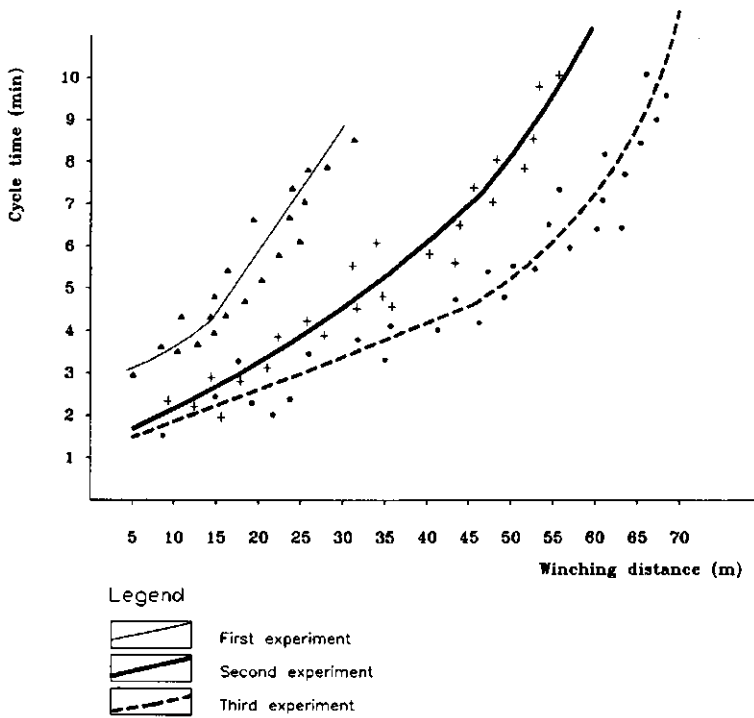


Fig. 6.4 Relationship between winching distance, cycle time and winch line dimensions

of experience in choker setting. In the last two experiments, the working method was developed further, and chokers were set during the winching and decking time. The difference in total cycle time increased with the winching distance.

**Cable weight.** The higher cycle times for the first experiment were mainly related to the dimensions of the winch line. The weight of the winch line caused much fatigue and delays when it was pulled out, especially when winching a distance of more than 15 m, denoting the impact of cable weight. One man could pull the line short distances, but as the weight increased with every step, another assistant was needed after 15 m. In addition, obstacles became more of a problem with increasing winching distance and more time was required for the crew to release hang-ups. The delays resulting from hang-ups also doubled the cycle time to 8.8 min at a distance of 30 m. Beyond 30 m the weight and stiff structure of the cable became prohibitive.

In the second experiment the cycle time was substantially less. The lighter and more flexible cable was the major factor for this together with the improved working method and more experienced crew. The work load was reduced as the winch line could be pulled with relative ease a distance of 45-50 m. A larger distance

results in a sharp rise of the cycle time marking the maximum distance for efficient winching. The factors responsible for this phenomenon were, as in the first experiment: increasing weight of the winchline and increasing delays caused by obstacles. In addition, for distances exceeding 50 m it was difficult for the choker setters and the skidder operator to communicate. While radio communication could overcome such problems, it is doubtful whether extension of the winching distance is really practical.

*Log size.* Winching was also facilitated by reducing the length of the logs to 7-10 m. The cycle time was reduced by 1-3 min (depending on the winching distance) by shortening the winching time. Other time elements were not affected. The advantage of shorter logs was better guidance and directing of moving logs, and reduced risk of hang-ups. The drawback is logically a reduction in winching production per unit of time. 'Short-wood logging' was considered as an option for damage-controlled logging (Oesterholt, 1986), but this method was not worked out because of the limited possibilities for adaptation to rain forest conditions.

The maximum skidding distance was not affected by shorter logs. Difficulties in pulling out a line and guiding a load more than 50 m were not solved sufficiently. Increasing the distance to 70 m, which is the maximum length of the winch line, increased the cycle time two or even threefold. The risk of damaging the cable also increased.

The pulling capacity of the winch was not a limiting factor in the tests. The problems of winching very heavy logs were related more to their dimensions than their weight. Sizeable logs were found to be very difficult to handle, both in choking and in guiding, while the chance of being blocked by trees and small obstacles increased. A log of approximately 10 tonnes (110 cm dbh and 11 m length) was the maximum load that could be handled. The cycle time, however, was raised to an unacceptable level and was manifold the time considered for economical winching production.

*Productivity.* The feasibility of the winching method is discussed in Chapter 7, here an indication of the productivity of the method is given. The required or allowable time to winch a standard load is derived by comparing prewinching with preskidding or presorting. The presorting time, that is the time to drive the skidder to the stump area to pick up and to transport the load to the trail, for a standard load of 4 tonnes is approximately 5.9 min (see Table 6.6). Winching a load of 4 tons (for instance, 2 logs of 2 m<sup>3</sup> or 1 log of 4 m<sup>3</sup>) would have taken 8 min (see Table 6.8 and Fig. 6.4). Compared with direct presorting with a skidder the winching technique is, therefore, less productive. The maximum allowable load for winching is approximately 6.5 tonnes, as higher loads will increase cycle time substantially.

## 6.4 Skidding efficiency in BSH logging

The BSH logging method is based on combined skidding. With this method logs are presorted by crawler tractors and then transported by wheeled skidders. The method is briefly described in Section 3.1.5, and in this section the efficiency of the method is discussed with regard to the various operations (Section 6.4.1) and production performance (Section 6.4.2).

### 6.4.1 Operational efficiency

Combined skidding is generally recommended as an efficient working method in selective logging in tropical rain forests and also in some types of temperate forests (FAO, 1974; 1977b; Conway, 1982). Having a low speed, high tractive power and high penetrating capacity, the crawler tractor is used to construct a trail system and to collect (presort or bunch) logs, whereas the speedy wheeled skidder is used to transport logs from a collection point to a forest landing. In this way, the features of both machines can be used optimally for efficient production. A prerequisite for this method is the construction of a trail system prior to felling.

Originally, BSH tried to maintain the above sequence of operations, but gradually developed its own method in which the tractive and dozing power of crawler tractors play a dominant role (Noelmans, 1979; van Leersum, 1984b). The current practices of BSH differed on vital points from the rational model.

In all surveyed logging compartments it was observed that skid trails were constructed by crawlers after tree felling. A topographic map (scale: 1 : 5000) was used to plan the main trails, which were widely spaced at 250 to 500 m, depending on the topography and hydrology of the logging compartment. The main trails were drawn on the tree location map used by a tree spotter who guided the operator of a D6 crawler tractor. The trails were not aligned in the forest, which means that the projection on the map could not be verified or corrected by field inspections. With the aid of the map only, the tree spotter indicated where a trail was to be constructed and how the work was to be done. The tractor operator received all instructions from the tree spotter when a trail was opened from the road side of a logging compartment.

The vegetation was dozed away and trail opening proceeded towards the rear boundary (south direction) of a compartment. When felled logs were found, a branch trail was constructed to the stump area. In this way construction of the main trail and branch trails was combined as the crawler moved through a compartment. Characteristic of this system is that the trail network was opened in one crawler passage over the total depth of a compartment. As branch trails were dozed, logs were simultaneously positioned for subsequent skidding.

The positioning of logs was another feature of the method. The aim was to position the logs conveniently for skidding, that is in a lifted position so that

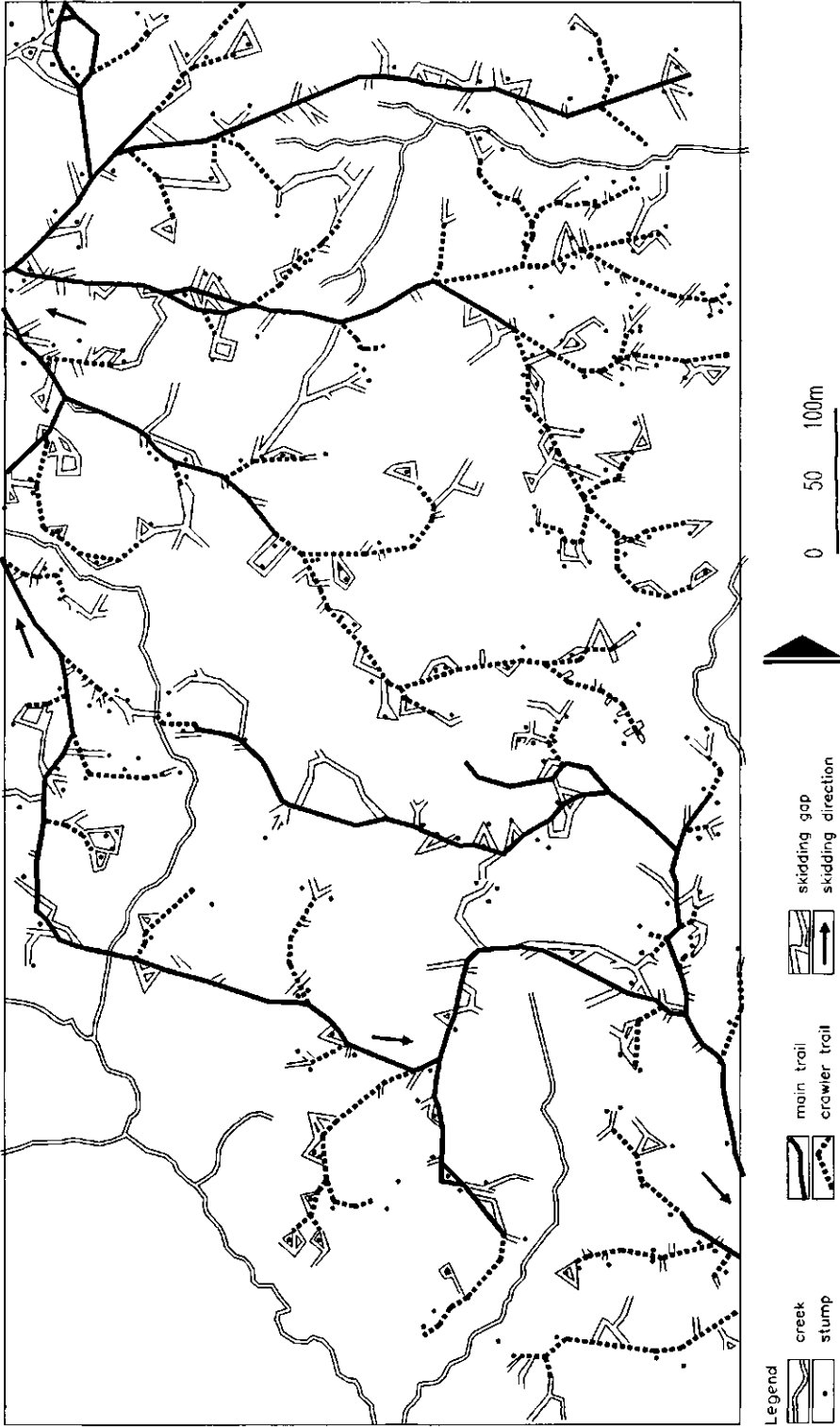


Fig. 6.5 BSH skidding: trail pattern of crawler tractor and wheeled skidder operations (Source: van Leersum, 1984b)

chokers could easily be set to the bud or leading ends. Positioning was done with the aid of the dozer blade and was often accompanied by clearing of adjacent vegetation. The dozer then proceeded with either trail opening or positioning of other logs. When a branch trail was ready, the crawler returned to the main trail to continue construction. At the end of a main trail, commonly the boundary of the logging compartment, the tractor returned to the truck road to start a new trail. On this return trip, a heavy log was selected for transport to a forest landing at the front end of the logging compartment.

A casual observer may consider the BSH skidding method to be efficient and well planned. At first sight the impression is of straight trails being constructed, while logs are located and prepared for skidding. A convenient situation is created for the skidding operations which allows quick and troublefree choking and hooking of logs to the winchline of the machine. Moreover, a powerful crawler is available to pull logs from hilly or wet sites where wheeled skidders cannot operate.

Complete mapping of the trail system of a logging compartment showed that the BSH skidding method was less efficient than could be anticipated on basis of the reconnaissance survey. The results of this study are presented in Fig. 6.5. A clear distinction should be made between main and branch trails and skidding gaps with regard to efficiency. Main and branch trail are components of the infrastructure of a logging compartment. The area occupied by these trails was assessed to be 7%. For transport efficiency the network should be qualified as being well designed because the shortest possible routes were projected on sites most suitable for trail building. When the network was established, the original design was not followed in all respects. The trail area should have covered 6% or even 5% of the compartment if the network had been aligned in the forest by a topographic crew. While contributing to damage restriction, such an improvement would be marginal for increased efficiency in spite of a slight reduction in average skidding distance. In fact, a job of amazing accuracy was performed by the crawler crew with the aid of very simple tools.

The weak point of the trail system is not the design and construction but the location on sites selected without field inspection. The sandy and loamy clays in the Patamacca region especially are known to have a low bearing capacity under wet conditions, as observed by the rapid deterioration of some trail sections. For this reason, the width of the trails measured in experimental units of 12 ha was 35% higher than strictly necessary for skidder transport. As a substantial part of the trails was on suboptimal soils, the trails were gradually widened as skidding proceeded to bypass deteriorated parts of the trail. The negative impact on efficiency was, therefore, not caused by poor network layout but by a reduction in travelling speed on deteriorated trail sections.

The relationship between skidding damage and skidding efficiency was obvious. Skidding impact was calculated as the surface of gaps and trails, caused by the presorting operations of the crawler. Apart from this damaging impact, presorting operations were highly inefficient. No less than 5.7% of the area was occupied by

trails and gaps of this category, which is 45% of the total trail surface. This means that almost half of the machine time of an operating crawler tractor was spent in presorting of logs. As in this method presorting comprised only adjustment of the lay and lifting of a log to a position convenient for skidding, and not the transport to a collecting point, a considerable number of machine hours were used for this work. Instead of pulling out the cable and winching the log to the branch trail, a path was dozered to the stump, and the dozer blade was used to direct logs and to lift their bud ends from the ground. Occasionally to facilitate skidding, logs were winched from hilly or swampy sites to a branch trail.

The BSH technique of presorting was developed to speed up skidder transport on the heavy clays of the Patamacca region. The power and tractive force of crawlers were misused to overcome technical problems in the next link of the transport chain.

#### 6.4.2 Skidding production

Given the system of combined trail construction and presorting of logs, the crawler tractor is essential for skidding production. The registration system of BSH offered a unique chance to analyse the time and working elements of the skidding method (see Section 3.5.3). The results of field observations and analysis of administration records are presented in Table 6.9. The study included presorting (collecting) and trail skidding data on 1683 logs. The calculated production figures were derived from three logging compartments at average skidding distances of 450 m, 1500 m, and 3000 m, corresponding with a number of transported log of 231 (13.7%), 411 (24.4%) and 1041 (61.8%) respectively.

The key problem in BSH skidding operations proved to be the excessive length of skid trails on soils of low bearing capacity. Skidding production decreased considerable

TABLE 6.9. Skidding efficiency: crawler and wheeled skidder production (m<sup>3</sup>/h)

| Skidder type*   | Production (m <sup>3</sup> /h) for skidding distance (m) |         |           |        |
|-----------------|--|---------|-----------|--------|
|                 | 50-100   | 300-600 | 1000-2000 | > 3000 |
| <b>Crawlers</b> |  |         |           |        |
| Caterpillar D6  | 6.2  | 4.4     | 2.1       | n.a.   |
| <b>Skidders</b> |  |         |           |        |
| Clark 666       | n.a.   | 7.3     | 5.8       | 3.5    |
| Timber Jack 450 | n.a.   | 8.1     | 5.6       | 3.3    |

Source: BSH (1978-1985)

\* See Table 3.2 for technical specification

rably with increasing skidding distance to an unacceptable low level of 3.5 m<sup>3</sup>/h (Clark skidder) and 3.3 m<sup>3</sup>/h (Timber Jack skidder) respectively. Inadequate planning of the skid trail system led to this unbalance in primary and branch trails and their suboptimal location. Consequently, the balance between presorting and skidding operations was also disturbed and crawlers had to assist in skidding logs to the landing. For these reasons, the BSH skidding method appeared to be the most expensive in Suriname.

Skidding was further hampered by poor technical condition of machines. This fact has been used by the company to explain the decreasing production of the last five years (BSH, 1979-1986), but the fact that the skidding distance has increased in the same period had been overlooked. Moreover, the technical deterioration of skidding machines is partly the result of misuse of dozing capacity of crawlers (see Section 6.4.1) and overloading of wheeled skidders, and less by obsolescence.

The root of BSH logging problems is managerial rather than technical. The major focus of the company is on wood processing, while logging is considered as timber supply only. As the company's processing plants depends on their own concessions for 80% of their timber stock, logging had become increasingly a bottleneck. The logging venture is managed from the office in Paramaribo and thus there is inadequate spot supervision. There is constant tension between plant and forest managers because the demands of the processing plants are not in balance with timber supply of the forest estate. These problems cannot be solved unless the logging venture gains a more independent status, which would enable more market oriented management (see Section 7.1.5).

## 6.5 Conclusions

*Felling efficiency.* The present study indicates that felling production is largely determined by effective crew time. The number of effective working hours per day was determined more by organizational than climatic factors. Experience in tropical timber harvesting indicates that only highly organized operations may achieve six effective working hours a day; the average is less than four hours (FAO, 1974b; 1977b).

The hypothesis that felling production is determined by the effective crew time rather than by the felling method (see Section 6.1.1) was confirmed by the analysis of the felling methods. Although the cycle time of 12.6 minutes (Table 6.2) in the controlled method was the highest (25% higher than BSH), this did not affect daily production significantly. Based on the cycle time and effective crew time, a theoretical production per day of 26.7 trees (approximately 56 m<sup>3</sup>) is possible with the controlled method, 30.9 trees (65 m<sup>3</sup>) under the BSH method and 18.3 trees (38 m<sup>3</sup>) following the conventional method. Actual production figures were lower

(see Table 6.1) because fellers were not able to maintain the same performance during regular work as during felling studies.

Observed time differences to perform the operations in the felling work cycle were of minor interest to felling production. A high felling efficiency is obtained by regular and safe work following a method serving the whole logging operations. In this respect, the controlled method is considered to be efficient and well suited to rational management of the tropical rain forest. The method is also attractive in terms of production as it is competitive with the purely commercial method of BSH.

The research experience with directional felling confirmed that this method could be used for trees up to 60 cm dbh. Between 60 cm and 80 cm dbh, the degree of the head lean determined the extent to which a tree could be directed. The average felling time increased significantly for tall or large trees with a heavy lean, while safety was affected negatively. Safety as well as efficiency considerations should be taken into account in deciding whether directional felling should be followed. Under all circumstances the use of wedges is recommended at least as a means to facilitate sawing and to improve safety.

*Skidding efficiency.* The impact on skidding efficiency was assumed to be also great as planning takes advantage of available terrain and stand data to locate the trail network on the best trafficable sites. The features of the conventional trail system enhancing stand and soil damage, were also determinants of skidding production. These are long skid trails with many curves and creek crossings and trail sections with low bearing capacity (see Section 4.1). Their combined impact may have a significant effect on skidding production because the round trip time will be increased and the payload reduced.

The poor technical quality of the forestry equipment is a structural problem in small-scale forest operations in Suriname. This situation is partly due to lack of capital and the reluctance of commercial banks to finance forestry machinery. Combined with a low level of organization and insufficient supervision of forest work, this has led to a low effective operational time in conventional skidding. Terrain transport has become the bottleneck in timber harvesting and often a large number of felled trees remain in the forest for months because of limited skidding capacity.

The CELOS skidders were hired from a machine supplier and from a concessionaire. The technical state and maintenance of the machines were secured by a contract. As the machines were only used for skidding work, a relatively high effective machine time was obtained. There is no doubt that a skidder should be kept in good technical condition and that work should be restricted to the operation for which it is designed. In this respect, the controlled system is superior to conventional logging. This conclusion stands regardless of differences in management practice and cost structure between the two compared systems.



On the basis of these findings it can be concluded that the higher skidding performance of the controlled method was a combined effect of a higher travelling speed and higher payload of the skidder. Apart from the technical state of the skidder, the trafficability of the trail system has also determined production efficiency.

## 7 CELOS Harvesting System

In spite of the substantial progress made in silvicultural research in tropical forestry, forest management systems based on integration of harvesting and silvicultural operations are still in the initial stages of development. Most systems, designed in the past few decades, focus on post-harvesting treatments of the remaining stand (Dawkins, 1958; Neil, 1981; Nicholson et. al., 1983). The tendency is to view controlled logging operations as a separate system and not as a component of an overall management system. Yet, the stimulating impact of selective logging on regeneration of tropical rain forests has been substantiated (Queensland Department of Forestry, 1983).

A sustainable management system based on natural regeneration of the remaining stand requires a scheme of strictly controlled silvicultural and harvesting operations to secure sustained timber production. To be economically viable, the system should have a limited number of objectives in order to safeguard the ecological stability of the managed forest. Although mechanized operations are inevitably part of today's logging practices, the use of advanced technology in tropical forestry should be adapted to local circumstances. Following these principles, structured systems can be developed for successful application in developing countries.

Sustained timber production is the main objective of the CELOS Harvesting System (CHS) which is considered to be applicable to the entire Forestry Belt of Suriname as well as to many other forest areas in the Amazon Basin (see Section 7.5). In this chapter the economic and ecological features of the CELOS Harvesting System are discussed and integrated with the findings of de Graaf (1986) and Jonkers (1987) to formulate a management system called CELOS Management System (CMS).

### 7.1 CELOS Management System

The CMS is a polycyclic management system with defined objectives and planned harvesting and silvicultural treatment (see Fig. 7.1). The CELOS Harvesting Systems is explained in Sections 7.2 and 7.3, and an overview of the CELOS Silvicultural System (CSS) is given in Section 7.4. For more detailed descriptions of

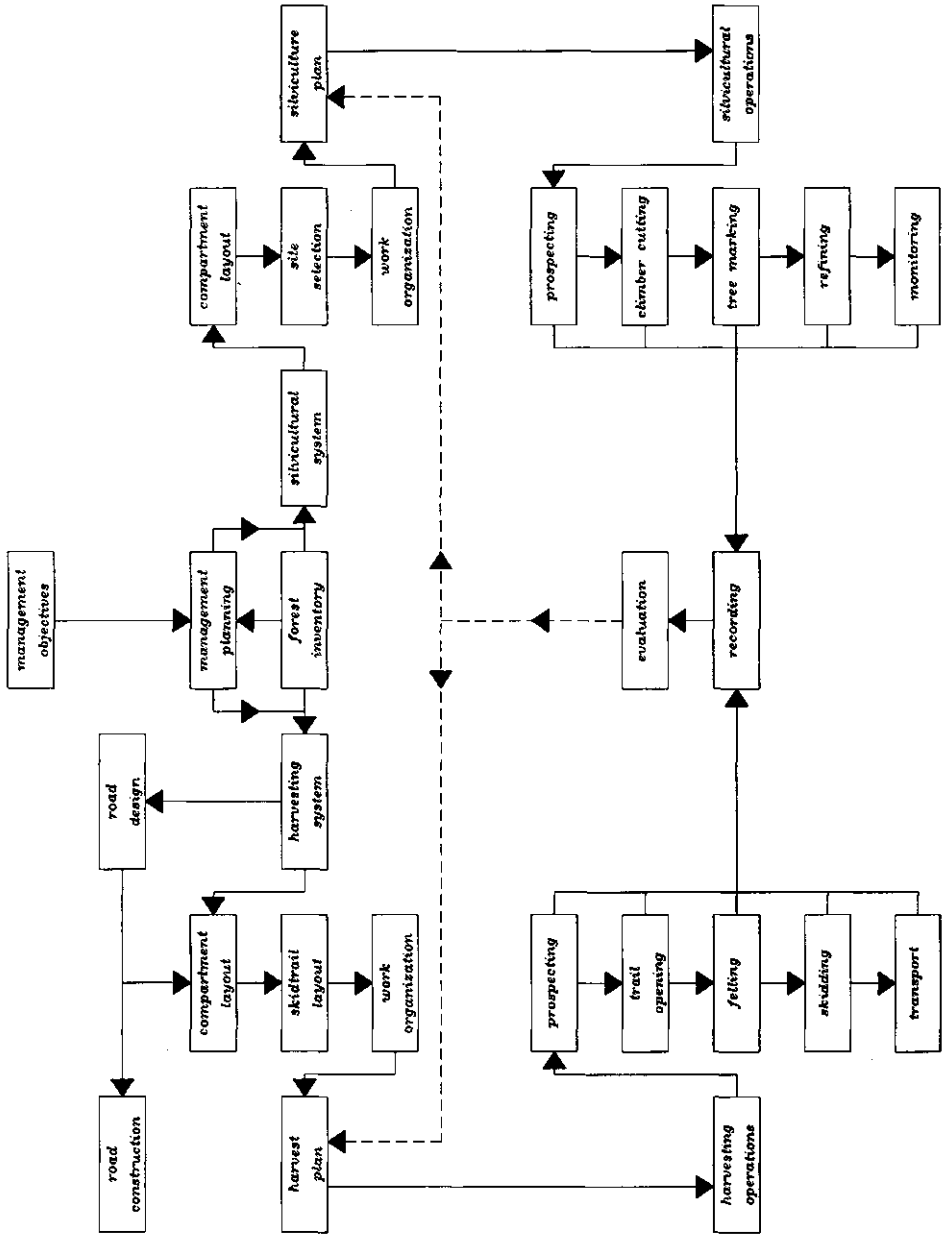


Fig. 7.1 Flowchart of the CELOS Management System

CSS, see de Graaf (1986) and Jonkers (1987). CMS is based on the following specific objectives and means:

- sustained production of quality commercial timber;
- a harvesting volume of approximately 30 m<sup>3</sup> per ha in a felling cycle of 20-25 years;
- maintenance of the ecological, conservation, and protective functions of the forest;
- controlled logging to restrict damage to the remaining stand, forest soil and harvested product;
- silvicultural tending and monitoring of the remaining forest between harvests;
- recording of all forest operations for cost and management control.

The system is based on a forest inventory which serves both harvesting and silvicultural treatments. Some forest operations can be carried out simultaneously, while others run sequentially. Although presented as a symmetric model with a sequence of activities, timber production, harvesting and silvicultural treatment are in fact continuous processes, with most operations being carried out in an orderly way within a short time period. Road planning covers the total area, and while including a good road system and facilities for labour and equipment, road engineering and logistics were not part of the present study and are, therefore, not detailed in the flow chart.

The interaction between management, harvesting, silviculture treatment and inventory planning is presented as a feedback mechanism to denote the system's dynamic character to handle a variety of site and stand factors. This feedback mechanism is demonstrated by the dotted lines in Figure 7.1.

Today's forest management has been defined as a series of human interventions aiming at sustainable forest production for present and future generations. As a coherent set of interventions, forest management aims at the ecological sustenance of the resource as well as by the socio-economic and continual availability of produce. Thus the CMS may be classified as a modern forest management system as it includes the economics of harvesting of commercial timber and silvicultural treatment within the limitations of the ecological stability of the forest. It is also a socially acceptable system because it is simple to implement and has the further advantage of creating employment for the rural people. There are, however, a number of constraints to application of CMS in tropical rain forest areas which are discussed below.

### *7.1.1 Legislative requirements*

Sustained yield management implies permanent allocation of an area for forestry and so does CMS. At least a long-term concession, in principle indefinitely

renewable, or type of ownership is needed to stimulate investment in sustained production. The responsible authority, for instance the Forest Service, has to have the legal and material means to implement large-scale management of rain forest areas.

Successful introduction of CMS in Suriname thus depends on policy changes regarding the legal status of the Forestry Belt, the establishment of management zones, and ownership of forest land. Previous studies on forest legislation, especially in the FAO project FO: SF/SUR/71/506 (FAO, 1971), have provided a framework for concession regulations and a draft of a modern forest law (King, 1972; Schmidhüsen, 1974). Unfortunately, successive governments have failed to formulate a modern and consistent forest policy and few legislative measures have been taken. The outdated Timber Ordinances of 1947 is still the only regulation for the harvesting of forest products on state land, and forestry development in Suriname is considerably hampered by political factors (Hendrisson and Jonkers, in press).

### *7.1.2 The management unit*

A forestry enterprise applying CMS requires a sound economic basis with a fixed management area and predetermined harvesting level. Based on the production objectives and the findings of the present study, the gross unit area for sustained forest management can be assessed as follows.

A balance of logging operations, including felling, preskidding (crawling) and trail skidding can be obtained with three felling crews, one crawler crew and two wheeled skidder crews working in one logging compartment (see Sections 6.2 and 6.4). This setup may be considered to be a standard logging unit of CMS. Approximately 125-150 m<sup>3</sup> per effective working day can be harvested from one logging unit. The number of effective working days per year can be set at 150 for well organized operations (Section 6.1), and consequently, the annual production at 18 750 - 22 500 m<sup>3</sup>. For a felling cycle of 25 years and a target harvest of 30 m<sup>3</sup>/ha, the annual coupe ranges from 625 to 750 ha and the area of production forest from 15 625 to 18 750 ha. If it is accepted that approximately 20% of the forest is non-productive or unmanageable (see Section 3.2), then the gross area of a management unit is about 22 500 ha, and may range from 20 000 to 25 000 ha depending on forest and terrain factors. Smaller areas and lower felling intensities may increase logging costs. If necessary, the production capacity of a standard unit could temporarily be extended by using hired equipment or by contracting private loggers. Larger ventures may include more standard units or even an entire management zone.

According to the forest land suitability classification of northern Suriname for sustained timber production (de Boer, 1981), there are three classes: S1 (highly suitable); S2 (moderately suitable); and S3 (marginally suitable). Land suitability

S1 has no significant limitations for sustained forest management, as soil conditions (texture, drainage, fertility and slope) are favourable for harvesting and natural regeneration practices. An area of approximately 570 000 ha in the Forestry Belt consisting of S1 and S2 has been assessed to be suitable for sustained yield management (de Boer, 1981).

Fraser (1981) proposed dividing the rain forests of northern Suriname into five management zones based on natural and administrative boundaries other than the traditional zones (see Section 2.5). Within the new management zones, the proportion of S1 and S2 soils is vital for sustained timber production. The smallest zone covers 60 000 ha and the other zones approximately 140 000 ha of forest suitable for sustained management, which means that a management zone can be divided into three to six management units each of about 25 000 ha.

Fraser's proposal is a clearly useful strategy to convert conventional harvesting practices into sustained yield forestry. The system has not been detailed but seems to be compatible with CMS as the latter can be applied at the management zone level. A CMS unit fits into the framework of logging ventures projected to supply a processing industry in a concentration point of a management zone (Fraser, 1981).

### *7.1.3 Logging intensity*

The logging intensity (number of trees harvested per ha) is an ecological constraint of CMS and should be limited in order to restrict stand and soil damage. Timber harvesting has to be compatible with forest preservation as ecological stability of the remaining stand is prerequisite for sustained production. Yet, the highest possible harvest should be envisaged to cover the costs of machinery, infrastructure, supervision and management. Thus the logging intensity should be determined carefully to bring economic and ecological targets into balance.

The first conservative estimate of allowable logging intensity of 20 m<sup>3</sup>/ha made in this framework (de Graaf, 1986) for the second harvest of silviculturally treated forests could be revised. According to Jonkers (1987), harvesting intensity of 30 m<sup>3</sup> per ha appears to be within the limits of controllable logging damage. Jonkers' study indicated that the increase in logging damage is less than proportional to the harvesting intensity. Increasing the harvested volume from 15 m<sup>3</sup> to 23 m<sup>3</sup> and even to 46 m<sup>3</sup> per ha gives a disproportional increase in area affected by felling and skidding. The findings of the present study indicate that controlled logging reduces the effects of logging intensity (Fig. 7.2). This is especially the case for controlled skidding, as the main trail system does not need to be extended when more trees are harvested. Additional logging damage is mainly caused by new felling gaps and branch trails.

One drawback of a high felling intensity is the extraction of nutrients from the forest ecosystem (Jonkers, 1987; Poels, 1987; Schmidt, in press). In order to

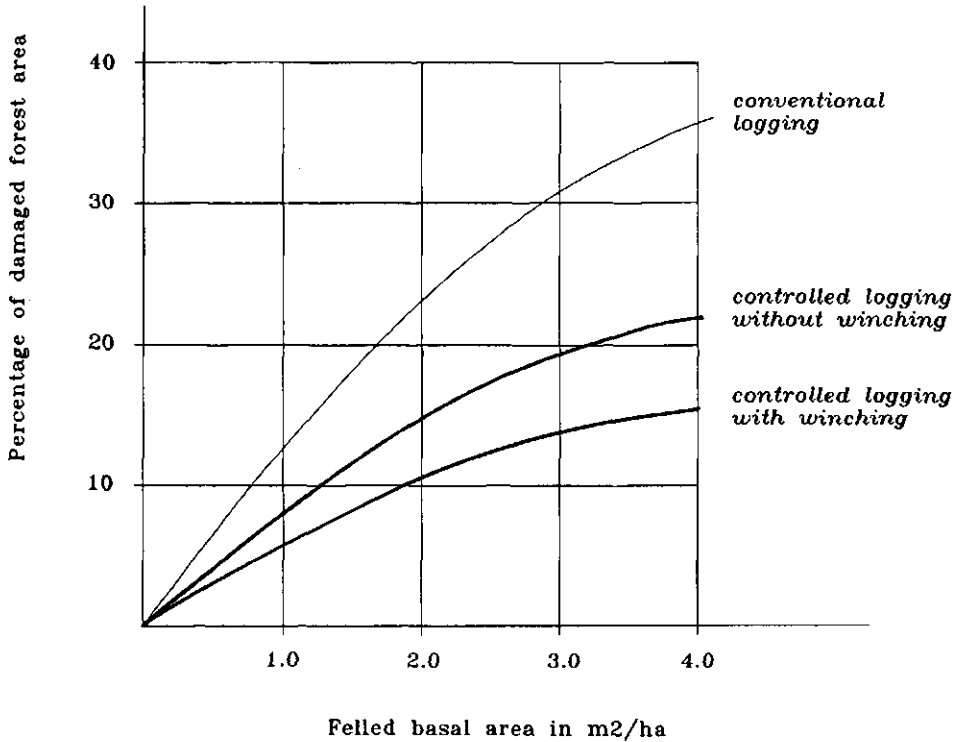


Fig. 7.2 Relationship between logging intensity and logging damage

minimize loss of nutrients, a logging intensity of 30 m<sup>3</sup>/ha should preferably not be exceeded. This target, however, should not be applied as an overall standard but be adapted to the quality of the stand. Flexibility is required to avoid damage to vulnerable sites on the one hand, and insufficient harvesting of well stocked stands on the other hand. Achieving a good balance in felling is part of the CMS strategy.

The relatively small proportion of commercial species in Suriname is an advantage for the application of CMS as usually there are no conflicts between short-term production objectives and ecological targets and there are no indications that this will change significantly in the near future. Taking into account all trees above 40 cm dbh of the CELOS list of commercial species (Appendix III), a gross volume of at most 40 m<sup>3</sup> per ha could be harvested in well stocked stands of the Forestry Belt. Heavily stocked stands, such as in the Kabo research area (Jonkers, 1987), may give higher yields, but on average the potential of harvestable timber is between 20 and 30 m<sup>3</sup> per ha. It is unlikely that this volume can be increased by including lesser known species given the technical and economic constraints to the processing and marketing of such species. According to the timber stock analysis of the Mapane forest (see Section 4.1) and other inventory data (LBB, 1971; ILACO, 1977), the rain forest types of the Forestry Belt have a relatively low

utilization potential as illustrated by the case study presented in Appendix VII.

The data in Appendix VII (Table VII.1) were derived from a forest area of 40 ha, from which approximately 200 m<sup>3</sup> per ha had been harvested for pulp. This experiment is an example of total timber utilization (biomass harvest) of a forest which had first been lightly harvested (LBB, 1971; de Graaf, 1986). The gross volume per use class indicates the maximum potential of commercial and lesser known species of trees > 20 cm dbh. Only a small proportion of the standing volume of 129.38 m<sup>3</sup>/ha is usable. When corrected for defects, conversion losses, processibility and marketability, the net yield of saw timber and veneer is estimated to be approximately 30 m<sup>3</sup>/ha (see Appendix VII). As yet there are no economic means to increase this quantity significantly. The practical consequence is that all prospected commercial trees can be harvested without risk of excessive logging damage.

#### *7.1.4 Mechanization and workers' skill*

CMS is a modern management system, using mechanization and technology to control costs, to prevent damage, and to improve working conditions. The dimensions of logs to be harvested are a limiting factor in manual skidding and transport.

Mechanization refers mainly to the harvesting component (CHS) of CMS and especially to timber extraction and transport. Workers have to be trained to handle the various tools and machinery, such as power saws, wheeled skidders and crawler tractors used in harvesting operations. Silvicultural operations, including liana cutting and refinement techniques, are done manually (Section 7.4).

As one of the principles of CHS is the integration of forest operations, forest workers should be able to perform all tasks in a job rotation system. Their basic training should include tree identification, tree mensuration, log scaling and recording, and power saw handling, all of which are essential for the integration of pre-harvesting and logging phases (Section 7.2). Job rotation is likely to lead to more enthusiasm and involvement of personnel, while the diversity of skills will allow for a more flexible organization. The results of the experiments on logging efficiency were very encouraging in this respect (Section 6.2). Damage was reduced when the same crews were responsible for prospecting, felling and skidding. The positive effect of job rotation on workers' attitudes and performance is supported by other studies in developed countries (Ager, 1985).

Some observations should be made on rewards for labour. Although not studied in detail, evaluation of the BSH system indicated that fringe benefits and premiums need to be handled carefully. Felling premiums as applied by BSH have led to wood damage and wood waste to no real economic advantage (see Section 6.4). The premium system should move from rewarding extra production to incentives for quality work, including damage prevention and logging efficiency. Training and rewarding of workers need to be part of the policy of sustained management.



### *7.1.5 Type of venture*

A private commercial venture based on allocated forest land has a vested interest in the regeneration of the remaining stand in order to stay in business.

One of the obstacles in tropical countries to developing a modern, efficient wood-based industry is the absence of a roundwood market. Large ventures have their own concessions and do not depend on private firms for supply of logs, whereas smaller sawmills are controlled by concessionaires (ADB, 1987). A change in government policy is needed to overcome this situation, and a new generation of entrepreneurs is needed to develop a roundwood market where producers and buyers can meet. A market mechanism may have a positive effect on logging efficiency because sound competition may force logging companies and middle-sized ventures to treat the forests entrusted to them as a renewable resource and may encourage them to make long-term investments. Government incentives are justified to create a new generation of entrepreneurs with understanding for long-term sustained yield management.

In Suriname, CMS is best executed by small to middle-sized private logging ventures under the supervision and assistance from the Forest Service. As suitable sites for sustained-yield forest management are scattered throughout the Forestry Belt, they are best managed by independent, self-supporting companies rather than by large enterprises. Thus BSH should divide its huge concessions into smaller units which can be managed as independent ventures with the company as shareholder. The Forest Service has an essential role in many respects including inspection and guidance of harvesting and silvicultural operations, where necessary. CMS can be a useful means in achieving forest management objectives and in bringing about changes in forest policy in Suriname.

### *7.1.6 Management planning*

'A modern forestry enterprise is like a manufacturing venture that works quietly, almost imperceptibly, and it is hard to see what is going on' (Davis and Johnson, 1987). There is no reason to assume that tropical rain forests should be managed differently from manufacturing enterprises. Planning, preparation, supervision and control of activities are prerequisites of all management systems.

The starting point of CMS is a forest area, allocated as a permanent management unit either by law or by ordinance. The unit should be planned and designed with the aid of all available information such as aerial photographs, terrestrial inventories, topographic and soil maps. A procedure to establish a standard unit is outlined as follows.

The first step is the identification of major forest types for timber harvesting, silviculture and forest conservation. Generally high forest is allocated as production forest and marsh forest along creeks as protection forest, while freshwater

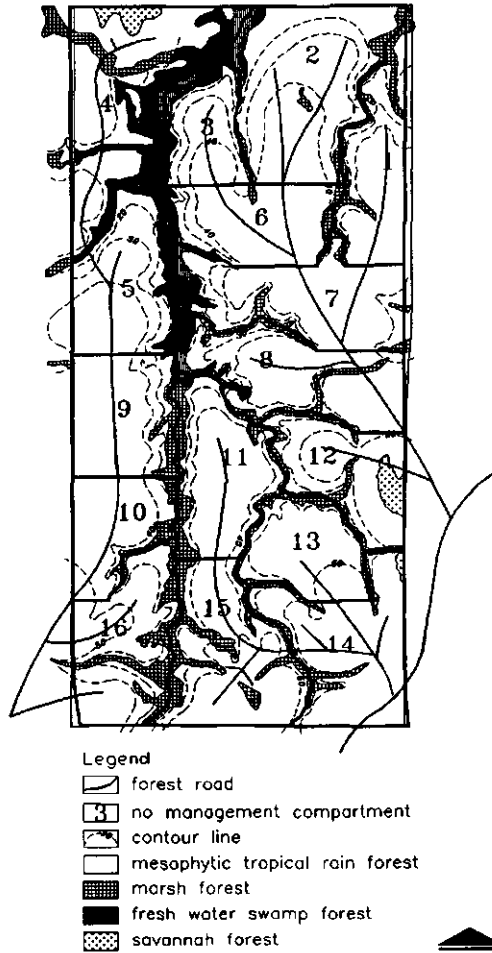


Fig. 7.3 A section of a management unit with compartment layout

swamp and savannah forest are investigated for production. The forest types are shown on the topographic map presented in Figure 7.3.

The second step is the design of a management plan, which stipulates the felling cycle, annual coupe and harvestable volume. The composition of the commercial stock and the site class may indicate the felling cycle. In the CMS a felling cycle of 20 – 25 years is envisaged from which an annual coupe of approximately 1000 ha is derived for a standard unit of 25 000 ha. Furthermore, the management plan includes road network to open up the forest, layout of the unit, and harvesting and silvicultural plans (Sections 7.2 and 7.3).

*Compartment layout.* Being the most elementary type of controlled timber harvest-

ting in tropical rain forests, compartment logging is widely used in management systems although not sufficiently developed to achieve sustained production. The method is based on the division of a forest area into harvesting compartments of 100-400 ha (FAO, 1973; SUDAM, 1977).

The traditional system of compartment logging needs to be adapted to the CMS. Instead of being restricted to an organizational unit for timber harvesting, a compartment should be defined as a harvesting and silvicultural unit in which operations are performed to attain certain management objectives. The term *management compartment* denotes the integration of logging and silviculture.

An example of a well-designed compartment layout is presented in Figure 7.3. Boundaries are formed by creeks, swampy sites, slopes, and inventory lines and forest roads where there are no natural boundaries. Production targets may influence the layout, but generally, terrain and forest characteristics are the determining factors. Management compartments do not necessarily have to yield equal volumes. The target volume should be derived from cost minimization including the cost of moving machinery from compartment to compartment.

*Road design.* A section of the secondary road system (branch roads) is also shown in Figure 7.3. These roads are projected along the water divides on sites of adequate soil strength. Compartment and road design are matched to obtain a well balanced layout. Theoretically, the road density may be derived from equation 7.1 (Sundberg and Silversides, 1988; also see Buongiorno and Gilles, 1987):

$$S = 2 \sqrt{\frac{C_r}{a \cdot Q}} \quad (7.1)$$

where:

- S = optimum spacing between roads;
- $C_r$  = cost of road building per unit length;
- a = variable skidding cost;
- Q = harvestable volume per unit of area.

The theoretical road spacing is meant as a check on a road layout as determined by terrain conditions and accessibility, rather than a prescribed standard. There is a tendency to economize on road construction by increasing skidding distances instead of finding the economic optimum between terrain and road transport. This was observed in the present study (see Section 6.4.2) and is common practice in other tropical countries (FAO, 1973; 1974).

A well designed road system can reduce the impact of road construction substantially. Useful guidelines have been given by Hamilton (1988) to minimize adverse effects as erosion and soil disturbance.

## 7.2 CHS: prospecting and harvesting planning

### 7.2.1 Prospecting

In addition to the road network, a skid trail network has to be planned to give access to harvestable trees. For this purpose, a more detailed enumeration is needed, this inventory known as prospecting is explained in Section 3.3.4. The importance of prospecting cannot be stressed enough. A 100% enumeration of harvestable trees is vital to achieve the aims of damage control, sustained yield and logging efficiency. At this point, CHS has the potential to restrict damage and to control cost simultaneously.

Attention should be paid to the training of a prospecting crew because 'prospectors' or tree spotters have to identify harvestable trees quickly and assess tree dimensions accurately. As tree enumeration in CMS serves both logging efficiency and silvicultural follow-up, field staff need to be trained for both operations.

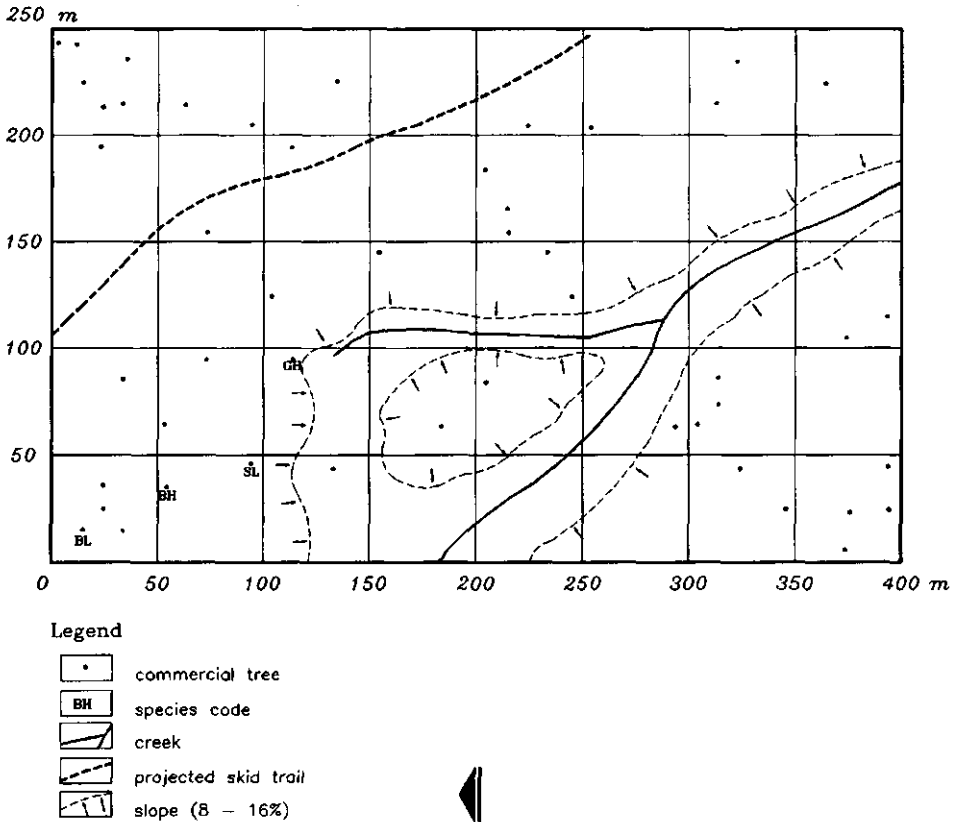


Fig. 7.4 Prospecting: tree location map

While the recording procedure in prospecting is very simple, accuracy is required to produce a useful tree location map. The following practical points supplement the method outlined in Section 3.3.4:

- Tree species and dimensions are best recorded in codes on waterproof sheets by the foreman (see Fig. 7.4).
- Selected trees can be marked with pre-numbered yellow or orange plastic labels fixed to their trunks. Each inventory unit should be numbered separately and consequently, each label should bear both a unit number and tree number.
- Tree diameter and height are assessed, but periodic checks with caliper and clinometer are recommended.
- Trees with future silvicultural functions, for instance, seed trees, have to be clearly marked with paint so that extra care is taken to protect them from felling damage.
- Identification of defective trees is very important. These trees are not felled but may be eliminated during silvicultural treatment (Section 7.4).

### *7.2.2 Compartment and site selection*

Detailed allocation of management compartments and the intensive site selection are also designed to reduce the costs of harvesting and silvicultural treatments. A management compartment is a harvesting and silvicultural entity with regard to sustained management. However, the decision as to which compartments are suitable for the CMS is based on prospecting and soil surveys. Compartments selected should be harvested differently to those not part of the production forest. On basis of site quality and commercial timber stocking, some parts of a management unit may not be considered suitable for sustained management, but may well contribute to timber production. These compartments should also be harvested carefully and efficiently, but the layout, especially the road and skid trail design, can be adapted to an occasional harvest.

Some sections in a compartment may have a protective function, for instance marsh and freshwater swamp forest, or may be excluded from production for other reasons. These sections should be indicated on the map.

### *7.2.3 Skid trail design*

An important feature of CHS is the establishment of a skid trail system prior to harvesting. The road system gives access to the forest estate (management unit) and connects the management compartments to each other and to landings and camp areas. The trail system, however, is compartment oriented, and thus each compartment should have its own skid trails.

Skidding is the most expensive sub-operation of timber harvesting and the cost is substantially influenced by the length and trafficability of trails (see Section 6.2). A skid trail system should, therefore, be designed in accordance with road and harvesting plans, management-compartment map (scale 1 : 5000), and topographic and prospecting data. The planning procedure starts at the office where each management compartment is treated as a harvesting unit.

The *main* or *primary trails* are part of the infrastructure of a management compartment and provide access to the compartment for machines. They should be located permanently on high, well-drained and trafficable ground as derived or assessed from mapped data. Their service life is not restricted to one harvest only, but related to felling cycles of 20 – 25 years.

The spacing of main trails is largely determined by terrain conditions, the harvestable stock, and the density of the road system (see Section 7.1.6). Spacing should be as wide as possible but should not exceed 100 m because the maximum distance for winching logs is approximately 50 m. This is also an economic distance for crawlers in presorting operations.

In addition to office design, field checks are needed to determine the final location. The trail design is worked out on maps for use by the trail-opening and harvesting crews.

*Branch* or *secondary trails* are projected towards the harvestable trees as identified from the tree location map. These trails are not permanent and their routes may vary from harvest to harvest. As they form the shortest connection between stumps and main trails their service life is generally restricted to a few days. Because of the low traffic intensity, trails could be made on soils less favourable for skidder movements. These sections, however, need to be clearly indicated so that harvesting in the wet season can be avoided or at least restricted.

Main trails should be aligned in the forest ('stripped or cutlassed') prior to opening in order to ensure that the planned layout is established (see Section 7.3.1). Branch trails need not be aligned for a trained skidding crew who are able to use a tree location map to search for logs. The trail layout as mapped is then a sufficient basis on which to decide whether a branch trail to the stump area has to be opened or whether logs can be winched to the main trail.

#### 7.2.4 Operational planning

All pre-harvesting and harvesting activities need to be set out in a plan of operations or harvest plan which should also include production estimates and stipulate harvesting and long-distance transport. The relevant parameters are harvestable volumes (m<sup>3</sup> per ha), tree dimensions and skidding distances. Other factors to be incorporated in planning are labour and machinery inputs, and felling and skidding outputs. The technical skill of workers is a decisive factor in the planning as well as the development of procedures for recording of all activities.

Logging production of a management compartment can be assessed by means of production diagrams. Such graphs can be adapted for a standard unit to be harvested by three felling crews, one crawler and two skidder crews. They can easily be prepared from inventory data, time and method studies or records of logging operations (FAO, 1978; Sundberg and Silversides, 1988; 1989).

### *7.2.5 Work organization*

There should be no doubt about the main objective of introducing CHS: damage control. Timber harvesting under CMS has to fit in with management objectives and constraints of the system and thus differs from purely commercial harvesting systems such as BSH- logging which, although efficient in many respects, have proved to be very damaging (see Section 6.4). The following description of the logging operations focuses on damage control.

The objective of damage control demands complete adherence to the harvesting regulations, which comprise of well planned and carefully executed operations. Successful conversion to this new management system requires special attention to staff training at all levels so that they become committed to damage-controlled logging.

Each management unit requires one prospecting-silvicultural crew of five men, two felling crews each of three men, one crawler crew of three men and two skidder crews each of two men. This scheme has been developed on the basis of the standard equipment used. The field manager is responsible for all harvesting and silvicultural operations, while an assistant manager is in charge of logging operations.

A prospecting crew can easily enumerate 20-25 ha per day (two inventory units of 10 or 12.5 ha respectively), that is four times the area that can be harvested by a standard logging unit (see Section 7.1.2). This means that the prospecting crew is available for other work, for instance silvicultural treatment. In practice, this is an advantage because prospecting should be done preferably 6 months prior to harvesting. It also allows for flexible planning of logging operations and for job rotation. The lack of interest demonstrated by workers in BSH logging is a weak point of a management system which gives insufficient attention to the physical and social aspects of the working method and environment. The prospecting crew, for instance, doing the same job year in year out, can complete their work in a 25 ha area in less than four hours and spend the rest of the day hunting. There is no sense of achievement or responsibility.

## **7.3 CHS: logging operations**

The present study has shown that careful logging is economically feasible and

ecologically acceptable. When the objective of maximizing short-term profits per area unit was replaced by sustained production, management policy had to be changed and logging methods modified. Surprisingly, these modifications were not drastic. Moreover, the same equipment was used for clean and efficient logging and to restrict damage to the remaining stands. As already explained, damage control is achieved mainly by planning and preparation of harvesting activities.

### *7.3.1 Trail opening*

Trails are opened prior to harvesting primarily to restrict logging damage (Section 3.1), but also to improve logging efficiency (Section 3.5). Projected trails have to be aligned and are best opened up by the crawler tractor (bulldozer) which is also used for road construction. Trails can be opened manually with the aid of power saws, as demonstrated in one of the logging experiments (Section 6.2).

Care should be taken not to dozer big trees. The total width of a primary trail should not exceed the over-tyre width of the skidder plus one metre, that is generally not more than 4 m. Sometimes, dozing of the forest floor should be avoided so that the organic layer and remnants of cleared vegetation remain to improve trafficability. Where skidder movement is hampered by soft soil, dozing of the top layer might improve trafficability. The dozer operator should be aware that requirements for skid trails are not the same as for road construction. Skid trails are usually not stabilized by a top layer of gravel. Yet this improvement is worthwhile on those parts of the network susceptible to disturbance. The idea behind damage-controlled skidding is to use the main trails again in future harvests. As long as old trails can be repaired, new ones should not have to be opened.

Primary trails can also be stabilized by dry compaction (see Section 5.5) done with an unloaded wheeled skidder traversing opened trails four to six times until maximum compaction is obtained. This treatment, which will improve trafficability, is also recommended for the repair of damaged trails after deep ruts have been filled with gravel or sand.

Bridging creeks with movable aluminium culverts or hollow trees covered with a soil bed (FAO, 1977b) is essential. The findings of this study (Sections 4.1 and 4.3) and earlier investigations (Conway, 1982) show that creek valleys are very susceptible to soil damage, and are a source of problems affecting skidding efficiency and damage prevention. Harvesting regulations are required to ensure that logging operations incorporate measures to prevent these problems.

Given the risk of bark and root damage, harvestable trees along primary trails should be felled and not reserved for future production. Such trees should be added to the felling list if not already selected by the prospecting crew.

Although trail opening with power saws has some positive points for damage control, this labour intensive and expensive method should only be used in



Suriname if a crawler tractor is not available. A light-weight saw may be used to clear a trail by felling trees above 15 cm dbh, whereas lower vegetation can be dozered by a wheeled skidder. Manual clearing provides a good opportunity to construct the trail carefully and overcomes the need to uproot large trees. The lower vegetation can be gradually cleared by the wheeled skidder and debris remaining on the trail will improve the bearing capacity at least temporarily. To avoid puncturing skidder tyres, trees need to be felled flat to the ground.

### *7.3.2 Felling operations*

The felling technique has to be adapted to control gap forming and damage to future trees as much as possible. This can be achieved by using the method of controlled felling described in Section 3.1. Compared to skidding, felling has become a relatively easy and cheap operation since the introduction of power saws in tropical timber harvesting. Felling can be carried out carefully at little extra cost and an orderly felling pattern makes skidding more efficient and consequently less expensive.

The technical side of felling with chain saws is well developed and good manuals are available to train workers (Conway, 1978; FAO, 1980). In the present study operators were found to have adequate technical skills for felling operations, but the problems identified were related more to damage control and safety (Sections 4.2 and 6.1). The main recommendations are related to organization, composition of the felling crew, as well as to the felling method.

*Organization.* As already stated, CHS is based on prospecting or tree location mapping to facilitate work organization and the search for harvestable trees. Management compartments are felled sequentially as stipulated in the management plan. Within a compartment, inventory units are systematically felled one by one, for example, by starting in the top section and continuing in the one direction towards the roadside landing of the compartment. For safety reasons only one crew is assigned per compartment.

Trees should be left standing until terrain and long-distance transport of logs can be arranged. Felling and skidding need to be well coordinated so that sufficient stock is felled to ensure that the skidder can operate continuously. A stock of a few weeks will generally guarantee this without exposing the logs to biological deterioration or other risks. Felling is the most flexible of all logging operations and far less sensitive to seasonal influences than skidding. This measure fulfils one of the objectives of damage control, namely reduction of wood decay by a more efficient operational planning.

*Crew and equipment.* The FAO (1980) recommendations on the composition and equipment of the felling crew were confirmed in the present study. With a

three-men crew led by the senior operator not only can felling production and work quality be improved if all crew members can handle a power saw, but also fatigue and accidents are prevented and motivation and involvement of all workers stimulated.

The dimensions of rain forest trees in Suriname allow the use of medium-weight power saws of approximately 8 kg. A crew should be equipped with two saws, spare chains and bars, and maintenance tools (FAO, 1980). Wedges are also needed for directional felling and damage control. All equipment should be well maintained. The relative low cost of felling equipment and the importance of this operation for the entire harvesting process justifies these investments. Safety clothing, helmets, gloves, ear and eye protectors are compulsory. These are presently available throughout the world and are well adapted to tropical climatic conditions.

*Method.* Felling preparations, felling and cross cutting, measuring and recording have been discussed in Sections 3.1 and 3.5. Here, emphasis is on the damage restriction aspects of controlled felling.

Given an abundance of lianas, woody climbers need to be cut prior to felling in order to restrict felling damage, and should preferably be combined with prospecting so that lianas die and rot before trees are felled. This operation could be combined with the requirements for the subsequent silvicultural treatments in one cruising (Section 7.4). Liana cutting is also recommended in other forest management systems (Fox 1968; Appanah and Putz, 1984; Putz, 1984).

Wedges are used in controlled felling for efficient and safe work, and to direct the lay of trees, especially smaller trees. Tested successfully in the logging experiments, this type of directional felling is recommended as standard practice for CHS. Power-saw operators require thorough training to master this felling technique.

Other measures to restrict felling damage include:

- felling smaller trees first so that they are not damaged by larger ones;
- avoiding wood waste by making the felling cut as close as possible to the ground and also by careful bucking and topping of the tree. The felled volume can be increased by 2-5% in this way (Section 4.4);
- timely transport of logs, if there is a risk of damage from other felled trees or insects;
- employing incentives to ensure quality work.

### 7.3.3 Skidding operations

Efficient and careful skidding depends on a well designed and established skid trail system as well as on the efficiency of the felling operations (Sections 7.2.3 and

7.3.2). The close relationship between felling and skidding is quite often insufficiently recognized by logging managers, and therefore these operations are often not properly coordinated. As with felling, skidding should be guided for efficiency and damage control.

The method best adapted to lowland tropical rain forest conditions is combined skidding. In this operation logs are collected by crawler tractor and transported further by wheeled skidders (Sections 3.1 and 6.4). This method had to be modified for damage-controlled skidding. The types of skidding machines used in the logging experiments were found to be well adapted to logging operations in Suriname (see Table 3.2).

A three-man crew, comprising an operator and two assistants, is required. As in felling, job rotation is strongly recommended in order to cope with the heavy work and to maintain the crew's motivation. Although essential, it is not easy to achieve job rotation because senior operators prefer to stay on their machines and leave the preparatory ground work to the choker men. Special training is needed for more job flexibility.

The procedure for collecting logs is different from that of BSH (Section 6.4). In principle, crawlers have to stay on the trails to winch logs from the stumps to the track. Only when winching is hampered by large obstacles may the machines change position or be driven closer to the stump area. A good trail network facilitates winching because it provides the shortest distance with the stump area.

Winching efficiency and damage control are also increased by an appropriate felling pattern. In addition, hang-ups (logs blocked by obstacles) can be released by resetting the winch line thus making winching suitable for a large number of felled trees. When these conditions are fulfilled, winching can be used on approximately 40% of the felled trees (Section 6.3).

Crews need to learn how to work carefully and how to use the power of a machine to prevent damage instead of inducing it. Conventional working methods concentrate on rapid log transport, and machine power is often misused in order to achieve this target. Winching aims at avoiding travelling through the stand, but more manual labour is needed to pull out a winch line to the logs. It is obviously more convenient for the assistants if the skidder enters the stump area. Taking a step back to more manual labour is rather a mental than physical barrier for conventional operators. Use of hydraulic winches with strong and relatively thin cables has proved to be a reasonable compromise. Two men are able to pull out the line easily to a distance of 50 m (Section 6.3). Winching tropical hardwoods with crawlers or skidders is technically, ergonomically and economically feasible.

If logs are properly collected and bunched (stored) along the trails, further transport with wheeled skidders is a relatively simple operation. Presorted and prechoked logs can be conveniently connected to the winch line. In this stage, skidding production is determined by the quality of the trail system rather than by operator's skill. For prevailing conditions in the Forestry Belt, the standard load for maximum travelling speed of the skidder was estimated to be 5 tons (Section

6.2). The optimal skidding distance is determined by the trail lay-out and verified by the road spacing equation (Section 7.1.6). Cost control of skidding is largely determined by the quality of the trails and justifies maintaining them in good condition.

No specific damage control measures have to be taken during winching and skidding. Damage prevention is integrated in the skid trail design and working method and in the trail maintenance, so that extension with branch trails is avoided or at least restricted. There are no provisions to employ special measures in selective logging to protect valuable trees in the stump area and along trails, as individual tree protection is not considered to be an adequate strategy in CHS (see Section 1.5).

Other skidding operations, such as choking techniques (Section 6.3.1), safe winching, storing of logs at landings (decking) and chemical protection against biological deterioration are not specific for CHS and well described in handbooks (FAO, 1973; Conway, 1982).

#### **7.4 CELOS Silvicultural System**

The silvicultural component of the CMS was developed by de Graaf (1986) and Jonkers (1987). Unlike harvesting, the silvicultural operations are performed manually at a low capital input. The method, mainly consisting of liberation of commercial trees by chemical thinnings of the remaining stand, is briefly described in Section 2.6. In this section the relationship between CSS and CHS is discussed.

According to de Graaf's list of operations (1986), a post-harvesting sampling is needed to determine the silvicultural treatment regime. This treatment involves a systematic chemical thinning of all non-commercial species above the target diameter at breast height in the first year after harvest. The method was modified by Jonkers (1987) and adapted to the quality of the remaining stand. In this treatment, termed 40/20-10, all lianas thicker than 2 cm have to be cut and non-desirable trees > 40 cm dbh thinned plus any trees > 20 cm dbh within 10 m of a desirable stem > 20 cm dbh. The result in stimulating increment of commercial trees is identical with the de Graaf's method, but the advantage is a less drastic opening of the canopy in poorly stocked parts of the stand and reduction in the amount of phytomass killed. Consequently, the costs of treatment are also reduced. Moreover, some of the non-commercial trees which may have a function in zoochorous seed dispersal (dispersed by animals) of commercial species can be maintained.

Treatment 40/20-10 has the potential to be an overall standard method of CSS, given its flexibility and economic and ecological advantages. A post-harvesting inventory to establish the treatment regime is no longer required. Liana cutting can be done before harvesting to restrict felling damage and to improve tree growth. This is another saving because one cruising of cutters is required instead of two. In

addition, the harvest prospecting can provide information on distribution and quality of commercial trees of interest for silvicultural treatments. Integration of preparatory harvesting and silvicultural operations is possible.

If logging is performed according to CHS standards, the first silvicultural treatment can be done one year after logging. Improved access to the forest provided by the skid trail network will also facilitate silvicultural operations.

Further studies are needed to detail follow-up silvicultural treatments. A second refinement is scheduled ten to eleven years after felling, and is predicted to result in another eight or ten years of good growth. This treatment should be mainly a type of thinning based on elimination of defective trees.

The third treatment is scheduled a few years before the next harvest. It is recommended that this be restricted to cutting of lianas and other measures to reduce logging damage and possibly competition of palms. Refining is not included for reasons of safety of the loggers or should be restricted to palms and small trees (Jonkers, 1987). It is worthwhile investigating whether these operations can be combined with other preparations for the subsequent timber harvest, such as opening of old skid trails and compartment boundaries and the starting of tree enumeration (prospecting).

### **7.5 Applicability of the CELOS Management System**

The CMS in its present form is the result of long-term investigation in forest management and silviculture in Suriname (see Chapter 2). However, the system is still in development and needs to be detailed. As a management system, it is considered to be applicable in the northern forest belt of Suriname and also in countries with similar forest types. According to de Graaf (1986) and Jonkers (1987), CSS can be implemented successfully in selectively harvested stands provided that sufficient sound commercial trees and regeneration have survived logging. In spite of limited practical experience with the system, CSS can be considered to be operational and ready for use in commercial forestry.

The CELOS Harvesting System is not only applicable in the rain forests of Suriname, but in many lowland rain forest areas provided that sustained production is envisaged, and consequently logging intensity is restricted. The type of damage-controlled logging as described in the present study has a wide applicability. The feasibility of the system is determined by terrain conditions rather than by forest characteristics. Everywhere in the tropics where wheeled skidders and crawler tractors can operate, that is where terrain conditions allow machine traffic, CHS can be used economically. The objective of damage control proved to be compatible with ecological objectives. The system has the potential to become a standard logging method for rain forest harvesting because it can be adapted to various site conditions.

Terrain slope is probably the main limitation of CHS. The system is not

TABLE 7.1. Logging cost of the CELOS, conventional and BSH harvesting systems

| Cost category            | Logging system |              |       |
|--------------------------|----------------|--------------|-------|
|                          | CELOS          | Conventional | BSH   |
| Mandays/m <sup>3</sup>   |                |              |       |
| prospecting              | 0.07           | n.a.*        | 0.05  |
| planning                 | 0.10           | n.a.         | 0.08  |
| felling                  | 0.08           | 0.07         | 0.08  |
| presorting               | 0.02           | 0.05         | 0.03  |
| skidding                 | 0.04           | 0.06         | 0.04  |
| Total                    | 0.31           | 0.18         | 0.28  |
| Machine h/m <sup>3</sup> |                |              |       |
| felling                  | 0.37           | 0.20         | 0.33  |
| presorting               | 0.07           | n.a.         | 0.22  |
| skidding                 | 0.16           | 0.39         | 0.18  |
| US \$/m <sup>3</sup> **  |                |              |       |
| labour                   | 6.20           | 3.60         | 5.60  |
| felling                  | 1.85           | 1.00         | 1.65  |
| presorting               | 4.20           | n.a.         | 13.20 |
| skidding                 | 8.00           | 19.50        | 9.00  |
| Total                    | 20.25          | 24.10        | 29.45 |

Source: logging data (Chapter 6)

\* n.a.: not executed in conventional logging

\*\* 1988 prices: power saw \$ 5/h; crawler \$ 60/h; skidder \$ 50/h; labour \$ 20/man-day (including overhead)

compatible with cable yarding methods. The maximum slope for economic skidding and crawling should not exceed 25% and the bearing capacity of the soil should preferably not exceed strength class 3 (Löffler, 1981; 1984). Further conditioning factors, such as log dimensions and spatial distribution of commercial trees, are of minor technical interest because the logging methods can be modified to handle, for instance, sizable logs or to harvest poorly stocked parts of the forest.

The research experience with CHS has provided a logging system which is economically viable and ecologically sound. The objective of damage-controlled logging was achieved satisfactorily while logging efficiency was also increased. Compared with conventional logging, harvesting damage (skidding and felling impacts) was reduced by approximately 40% at a felling intensity of 20 m<sup>3</sup>/ha. Skidding impacts were restricted to 5-7% of the harvested area compared with 14% in conventional logging. Felling efficiency remained the same in both systems which means that measures to control felling damage have not increased costs substantially. Skidding production in CHS increased by 20% with no extra measures other than management planning, preparation of logging operations and improvement of working methods.

CHS is less costly than traditional logging (see Chapter 6 and Table 7.1). Testing CHS on practical scale indicated that damage-controlled logging is not necessarily more expensive than commercial logging focusing on efficiency only. The measures to prevent logging damage are integrated in the management system, and only the initial cost of introducing CHS has to be considered. The felling cost is affected by damage control, but is assessed to be no more than US\$ 1.85/m<sup>3</sup> on 1988 prices (see Table 7.1). Skidding and presorting costs could rise initially by 10-20% and then decrease gradually to US\$ 12.20/m<sup>3</sup>. The additional cost of planning (including preparations and supervision) to fulfil the objectives of damage control are returned by improved operational efficiency. Thus CHS can be applied economically in commercial logging.

Further research should focus on the entire management system, including the detailed integration of CHS and CSS. In principle, there are no specific restrictions to use CHS in various types of managed forests. Where the silvicultural regime has not yet been determined, CHS can at least be used as a first silvicultural treatment to create favourable circumstances for further management.

## References

- ADB, 1987. A review of forestry and forest industries in the Asia-Pacific region. Asian Development Bank, Manila, The Philippines.
- AGER, B., 1985. Healthy forests and healthy forest workers. in Oswald, M. (ed.), Human impacts on forests. (IUFRO Symposium, Strasbourg 1984). INRA, Paris, France.
- ANONYMUS, 1985. Waldschonende Holzernte. (Proceedings). Kuratorium für Waldarbeit und Forsttechnik, Ruhpolding, Federal Republic of Germany.
- APPANAH, S AND PUTZ, F.E., 1984. Climber abundance in virgin Dipterocarp forest and the effect of pre-felling climber cutting on logging damage. *The Malaysian Forester*, 47, 335-342.
- ASHTON, P.S., 1981. Forest conditions in the tropics of Asia and the Far East. in Sutlive, V.H., Althuler, N. and Zamora, M.D. (eds), Where have all the flowers gone? College of William and Mary, Williamsburg, USA.
- BARRERA, C., 1987. Utilization of natural forests in the Pacific Coast Region of Colombia. in Figueroa J.C. (ed.), Management of the forests of Tropical America: prospects and technologies. (Conference Proceedings). USDA Forest Service, San Juan, Puerto Rico.
- BEEKMAN, F., 1987. Soil strength and forest operations. (Thesis). Wageningen Agricultural University, The Netherlands.
- BENNEMA, J., 1982. Acid soils of the humid tropics of Sout America, with special reference to the well-drained soils on old alluvial sediments. in Wienk, J. F. and Wit, H.A. de (eds), Management of low fertility acid soils of the American humid tropics. Inter-American Institute for Cooperation on Agriculture, San José, Costa Rica.
- BERKHOUT, A.H., 1903. Rapport over de Surinaamse bossen. Mouton, The Hague, The Netherlands.
- BERKHOUT, A.H., 1917. Rapport over het Surinaamse Boswezen. Algemene Landsdrukkerij, The Hague, The Netherlands.
- BEUSEKOM, C.F. VAN, GOOR, C.P. VAN, AND SCHMIDT, P. (eds), 1987. Wise utilization of tropical rain forest lands. (Tropenbos Scientific Series 1). The Tropenbos Programme, Ede, The Netherlands.
- BHADRAN, C.A.R., 1965. The introduction of regular forest management. (Report to the Government of Suriname). FAO, Rome, Italy.
- BIOTROP, 1978. Symposium on the long-term effects of logging in South East Asia. (Conference proceedings). BIOTROP, Bogor, Indonesia.
- BOER, M.W.H. DE, 1972. Landforms and soils in eastern Suriname. PUDOC, Wageningen, the Netherlands.
- BOER, M.W.H. DE, 1981. A system of soil classification for Suriname. (Report 70). Soil Survey Department, Paramaribo, Suriname.



- BOERBOOM, J.H.A., 1965. De natuurlijke regeneratie van het Surinaamse mesofytische bos na uitkap. Wageningen Agricultural University, The Netherlands.
- BOERBOOM, J.H.A. AND JONKERS, W.J.B., 1987. Land use in tropical rain forest areas. in Beusekom, C.F. van, Goor, C.P. van and Schmidt, P. (eds), Wise utilization of tropical rain forest lands, 30-45. (Tropenbos Scientific Series 1). The Tropenbos Programme, Ede, Wageningen.
- BOERBOOM, J.H.A. AND WIERSUM, K.F., 1983. Human impact on Tropical moist forest. in Holzner, W., Werger, M.J.A. and Ikusima, I. (eds), Man's impact on vegetation. Junk Publishers, The Hague, The Netherlands.
- BOL, M.M.G.R., 1968. Moderne Houtoogstmethode in Zweden. Nederlands Bosbouw Tijdschrift, **39**, 508-516.
- BOL, M.M.G.R., 1985. Summary and conclusions of cummunications and discussions (Division 3). in: Oswald, M. (ed.), Human impacts on forests. (IUFRO Symposium, Strasbourg 1984). INRA, Paris, France.
- BOL, M.M.G.R. AND BEEKMAN, F., 1989. Economically and environmentally sound harvesting methods. Communications of the Norwegian Forest Research Institute, **41**, 319-330.
- BOL, M.M.G.R., AND LEEK, N.A., 1985. Forest Operations and changing management practices. in Oswald, M. (ed.), Human impacts on forests. (IUFRO Symposium, Strasbourg 1984). INRA, Paris, France.
- BOWELS, R.J., 1974. Forestry development in Suriname: forest based industry development (Saw mill and panel board enterprises). FAO, Rome, Italy.
- BOXMAN, O., in press. Deterioration of the nutrient store at removal of a rain forest in Suriname. (Ecology and management of tropical rain forests in Suriname). [Provisional title]. Wageningen Agricultural University, The Netherlands.
- BOXMAN, O., GRAAF, N.R. DE, HENDRISON, J., JONKERS, W.B.J., POELS, R.L.H., SCHMIDT, P. AND TJON LIM SANG, R., 1985. Towards sustained timber production from tropical rain forests in Suriname. (Special Paper 9th World Forestry Congress, Mexico City). Netherlands Journal of Agricultural Science, **33**, 125-132.
- BOXMAN, O., GRAAF, N.R. DE, HENDRISON, J., JONKERS, W.B.J., POELS, R.L.H., SCHMIDT, P. AND TJON LIM SANG, R., 1987. Forest land use in Suriname. in Beusekom, C.F. van, Goor, C.P. van and Schmidt, P. (eds), Wise utilization of tropical rain forest lands. (Tropenbos Scientific Series 1). The Tropenbos Programme, Ede, The Netherlands.
- BRUIJNING, C.F.A., VOORHOEVE, J. AND GORDIJN, W. (EDS) 1977. Encyclopedie van Suriname. Argus Elsevier, Amsterdam, The Netherlands.
- BRÜNIG, E.F., 1983. Vegetation structure and growth. in Golley, F.G. (ed.), Tropical rain forest ecosystems: structure and function. (Ecosystems of the world 14A). Elsevier Scientific Publishing Company, Amsterdam, The Netherlands.
- BRÜNIG, E.F., 1984. Nutzbarmachung des tropischen Regenwaldes: Eldorado oder Pandora? Geographische Rundschau **36**, 353-358.
- BSH, 1979-1986. Technische jaarverslagen rondhoutproductie. (Annual logging reports). BSH, Paramaribo, Suriname.
- BUBBERMAN, F.C., 1973. De bosbranden van 1964 in Suriname. Nieuwe Westindische Gids **49**, 163-173.
- BUBBERMAN, F.C. 1980. Bosinventarisatie in Suriname. ELDORADO, **1**(1), 8-16.
- BUBBERMAN, F.C. AND VINK, A.T., 1966. Ditchblasting as a method of opening up

- tropical swamp forest in Suriname. *Netherlands Journal of Agricultural Science*, **14**, 103-126.
- BUONGIORNO, J. AND GILLES, J.K., 1987. *Forest management and economics*. Macmillan Publishing Company, New York, USA.
- BURINGH, P., 1979. *Introduction to the study of soils in tropical and subtropical regions*. PUDOC, Wageningen, The Netherlands.
- CATERPILLAR, 1986. *Caterpillar performance handbook*. Caterpillar Tractor Company, Peoria, USA.
- CESWO, 1981. *Structurele en financieel-ekonomische aspekten van de rondhoutwinning en rondhoutverwerking*. Stichting Planbureau Suriname, Paramaribo, Suriname.
- COHEN, A. AND EYK, J.J. VAN DER, 1953. *Classificatie en ontstaan van savannen in Suriname*. *Geologisch Mijnbouwkundig Nieuws Suriname*, **15**, 202-214.
- CONWAY, S., 1978. *Felling practices*. Miller Freeman Publications, San Francisco, USA.
- CONWAY, S., 1982. *Logging practices*. Miller Freeman Publications, San Francisco, USA.
- DAVIS, L.S. AND JOHNSON, K.N., 1987. *Forest management*. McGraw-Hill Book Company, New York, USA.
- DAWKINS, H.C., 1958. *The management of natural tropical high forest with special reference to Uganda*. (IFI Paper 34). Imperial Forestry Institute, Oxford, United Kingdom.
- DIETZ, P., 1981. *Vermeidung und Behandlung von Rückeschäden*. *Allgemeine Forst Zeitschrift*, **36**, 263-265.
- DILLEWIJN, F.J. VAN, 1957. *Sleutel voor de interpretatie van begroeiingsvormen uit luchtfoto's 1 : 40 000 van het noordelijk deel van Suriname*. Suriname Forest Service, Paramaribo, Suriname.
- ERDAS, O., 1976. *Bodenmechanische Probleme der Befahrbarkeit, der Bodentragfähigkeit und des Holzrückens in natürlichen Böden des Schweizerischen Mittellandes*. Eidgenössische Technische Hochschule, Zürich, Switzerland.
- ESSED, F.E., 1973. *Een volk op weg naar zelfstandigheid*. Stichting Planbureau Suriname, Paramaribo, Suriname.
- ESTÈVE, J., 1983. *La destruction du couvert forestier consécutive à l'exploitation forestière de bois d'oeuvre en forêt dense tropicale humide africaine ou américaine*. *Bois et Forêts des Tropiques*, **201**, 77-84.
- FAO, 1971. *Forestry Development in Suriname*. (Project FO:SF/SUR/71/506). FAO, Rome, Italy.
- FAO, 1973. *Logging and transportation in Peninsular Malaysia* (FO: DP/MAL/72/009 Technical Report 8). FAO, Rome, Italy.
- FAO, 1974. *Logging and log transport in tropical high forest*. (Forestry Development Paper 18). FAO, Rome, Italy.
- FAO, 1977a. *Kuantan forest management unit: forest land use, forest management and operation plans* (Project FAO/MAL/75/012 Technical Report 2). Forestry Department, Kuala Lumpur, Malaysia.
- FAO, 1977b. *Planning forest roads and harvesting systems*. (FAO Forestry Paper 2). FAO, Rome, Italy.
- FAO, 1978. *Assessment of logging costs from forest inventories in the tropics*. (FAO Forestry Paper 10/1 and 10/2). FAO, Rome, Italy.
- FAO, 1980. *Chainsaws in tropical forests*. (FAO Training Series 2). FAO, Rome, Italy.

- FAO, 1983. Simple technologies for charcoal making. (FAO Forestry Paper 41).  
FAO, Rome, Italy.
- FAO, 1985. Tropical Forestry Action Plan. FAO, Rome, Italy.
- FOX, J.E.D., 1968. Logging damage and the influence of climber cutting prior to logging in the lowland Dipterocarp forest of Sabah. *Malayan Forester* **31**, 326-347.
- FRASER, A.I., 1973. Forestry development in Suriname: forest management. FAO/Suriname Forest Service, Paramaribo, Suriname
- FRASER, A.I., 1981. Forest sector plan Suriname: forest resources and production forecasts 1985-2005. Suriname Forest Service, Paramaribo, Suriname.
- FRASER, A.I., BUSBY, R.J.N. AND PAUL, D.K., 1977. Forest regeneration Suriname. International Forest Science Consultancy/Suriname Forest Service, Paramaribo, Suriname.
- FROEHLICH, H.A., 1978. Soil compaction from low ground-pressure, torsion-suspension logging vehicles on three forest soils. (Research Paper 36). Forest Research Laboratory, Corvallis, USA.
- FROEHLICH, H.A., AULERICH, D.E., CURTIS, R., 1981. Designing skid trail systems to reduce soil impacts from tractive logging machines. (Research Paper 44). Forest Research Laboratory, Corvallis, USA.
- GONGGRIJP, J.W. AND BURGER, D., 1948. Bosbouwkundige studiën over Suriname. Veenman, Wageningen, The Netherlands.
- GONGGRIJP, L., 1925. Bosexploratie in Suriname. (Bulletin 48). Departement van Landbouw, Nijverheid en Handel, Paramaribo, Suriname.
- GRAAF, N.R. DE, 1982. Sustained timber production in tropical rain forest of Suriname. in Wienk, J.F. and Wit, H.A. de (eds), Management of low fertility acid soils of the American humid tropics. Inter-American Institute for Co-operation on Agriculture, San José, Costa Rica.
- GRAAF, N.R. DE, 1983. Bosbouw en tropisch regenwoud in Suriname. *Nederlands Bosbouw tijdschrift* **55**, 199-211.
- GRAAF, N.R. DE, 1986. A silvicultural system for natural regeneration of tropical rain forests in Suriname. (Ecology and management of tropical rain forests in Suriname 1). Wageningen Agricultural University, The Netherlands.
- GRAAF, N.R. DE AND GEERTS, J.M.P., 1976. Techniek natuurlijke verjonging drooglandbos. (CELOS Rapporten 114). Centrum voor Landbouwkundig Onderzoek in Suriname, Paramaribo, Suriname.
- GRAAF, N.R. DE AND HENDRISON, J., 1987. Notas sobre el manejo del bosque alto seco en Suriname. in Acta del primer seminario internacional sobre manejo del bosque tropical humedo en al region de Centro America. ESNACIFOR, Siguatepeque, Honduras.
- GURMIT SINGH, K.S., 1981. Destroying Malaysian forests. in Sutlive, V.H., Althuler, N. and Zamora, M.D. (eds), Where have all the flowers gone? College of William and Mary, Williamsburg, USA.
- HALLÉ, F., OLDEMAN, R.A.A., AND TOMLINSON, P.B., 1978. Tropical trees and forests: an architectural analysis. Springer Verlag, Berlin, Federal Republic of Germany.
- HAMILTON, L.S., 1988. Minimizing the adverse impacts of harvesting in humid tropical forests. in Lugo, A.E., Clark, J.R. and Child, R.D. (eds), Ecological development in the humid tropics. Winrock International Institute for Agricultural Development, Morrilton, USA.
- HARTGE, K.H. AND SOMMER, C., 1982. Einfluss der Bodenentwicklung auf den

- Zusammenhang zwischen Lagerungszustand und vertikaler Spannung im Boden. *Zeitschrift für Pflanzenernährung und Bodenkunde*, **145**, 25-35.
- HATCHELL, G.E. AND RALLSTON, C.W., 1971. Natural recovery of surface soils disturbed in logging. *Tree Planters Notes*, **22**(2), 5-9.
- HEIJ W. AND LEEK, N.A., 1981. Impact of wood harvesting technology on soil and vegetation. in *Proceedings IUFRO World Congress 17*. IUFRO, Kyoto, Japan.
- HENDRISON, J., 1984. Harvesting Systems. in Project LH/UvS 01, Human Interference in the Tropical Rainforest Ecosystem, Annual Report 1983. CELOS, Paramaribo, Suriname.
- HENDRISON, J. AND JONKERS, W.B.J., IN PRESS. Forestry in Suriname. in *Management of Tropical moist forest in Latin America*. [Provisional title]. FAO, Rome, Italy.
- HILDEBRAND, E.E., 1983. Der Einfluss der Bodenverdichtung auf die Bodenfunktionen im forstlichen Standort. *Forstwissenschaftliches Centralblatt*, **102**, 111-125.
- HILF, H.H., 1965. Forstgerechtes Baumfällen im Tropenwald. *Forstarchiv*, **36**, 38.
- HILLEL, D., 1980. *Fundamentals of Soil Physics*. Academic Press, New York, USA.
- HORNICK, J.R., ZERBE, J.I. AND WITHMORE, J.L., 1984. Jari's Success. *Journal of Forestry*, **82**, 663-667.
- HUSCH, B., 1971. Planning a forest inventory. *FAO Forestry and Forest Products Studies 17*. FAO, Rome, Italy.
- ILACO, 1977. MAPES, een haalbaarheidsstudie over de stichting van een bedrijf voor de op- en bewerking van naald- en hardhout gewonnen uit het Mapane gebied. ILACO/Suriname Forest Service, Paramaribo, Suriname.
- INFORSON, 1979. Timber resources in East and Central Suriname. International Forest Science Consultancy/Suriname Forest Service, Paramaribo, Suriname.
- JACOBS, M., KRUK, R. AND OLDEMAN, R.A.A., 1988. *The tropical rain forest: a first encounter*. Springer, Berlin, Federal Republic of Germany.
- JAPING, C.H. AND JAPING, H.W., 1960. *Houthandboek Surinaamse houtsoorten*. Suriname Forest Service, Paramaribo, Suriname.
- JONKERS, W.B.J., 1984. Exploitation, natural regeneration and increment. (CELOS rapporten 141). CELOS, Paramaribo, Suriname.
- JONKERS, W.B.J., 1987. Vegetation structure, logging damage and silviculture in a tropical rain forest in Suriname. (Ecology and management of tropical rain forests in Suriname 3). Wageningen Agricultural University, The Netherlands.
- JONKERS, W.B.J. AND HENDRISON, J., 1987. Prospects for sustained yield management of tropical rain forest in Suriname. in Figueroa J.C. (ed.), *Management of the forests of Tropical America: Prospects and technologies*. (Conference Proceedings). USDA Forests Service, San Juan, Puerto Rico.
- JONKERS, W.B.J. AND SCHMIDT, P., 1984. Ecology and timber production in tropical rain forest in Suriname. *Interciencia*, **9**, 290-298.
- KAPPLER, A., 1983. *Zes jaren in Suriname 1836-1842*. De Wallburg Pers, Zutphen, The Netherlands.
- KASRAN, B., 1989. Effect of logging on sediment yield in a hill Dipterocarp forest in Peninsular Malaysia. *Journal of Tropical Forest Science*, **1**, 56-66.
- KING, K.F.S., 1972. *Forestry Development in Suriname: forest concession legislation and forest concession agreements*. FAO/Suriname Forest Service, Paramaribo, Suriname.

- KNUCHEL, H., 1947. Management control in selection forest. Imperial Forestry Bureau, Oxford, United Kingdom.
- KNUTELL, H., 1983. Stand damages in thinnings, a comparison of some Swedish thinning methods. Swedish University of Agricultural Sciences, Garpenberg, Sweden.
- KOOLEN, A.J., 1986. Deformation and compaction of elemental soil volumes and effects on mechanical soil properties. *Soil and Tillage Research*, **10**, 5-19.
- KOOLEN, A.J. AND KUIPERS, H., 1983. *Agricultural soil mechanics*. Springer Verlag, Berlin, Federal Republic of Germany.
- KOOREVAAR, P., MENELIK, G. AND DIRKSEN, C., 1983. *Elements of soil physics*. Elsevier, Amsterdam, The Netherlands.
- KROCHMAL, A. AND KROCHMAL, C., 1986. Let there be forest. PUDOC, Wageningen, The Netherlands.
- LAARMAN, J., VITRANEN, K. AND JURVELIUS, M., 1981. Choice of technology in forestry: a Philippine case study. New Day Publishers, Quezon City, Philippines.
- LANLY, J.P., 1982. Tropical forest resources. (FAO Forestry Paper 30). FAO, Rome, Italy.
- LBB, 1960. *Bosbedrijfsplan Patamacca*. Suriname Forest Service, Paramaribo, Suriname.
- LBB, 1961. *Bosbedrijfsplan Mapane VI*. Suriname Forest Service, Paramaribo, Suriname.
- LBB, 1971. *Jaarverslag (Annual report) 1970*. Suriname Forest Service, Paramaribo, Suriname.
- LBB STATISTICS, 1960-1980. (Forestry data from annual reports). Suriname Forest Service, Paramaribo, Suriname.
- LEERSUM, G.J.R. VAN, 1984a. *Winchsystems and short-wood logging*. (Unpublished M.Sc. thesis). Wageningen Agricultural University, The Netherlands.
- LEERSUM, G.J.R. VAN, 1984b. *Uitsleepschade*. (CELOS rapporten 143). CELOS, Paramaribo, Suriname.
- LEERSUM, G.J.R. VAN, AND ZIJP, M.A., 1985. *Heli-logging in het tropisch regenwoud*. (Unpublished M.Sc thesis). Wageningen Agricultural University, The Netherlands.
- LEVITT, J., 1980. *Responses of plants to environmental stresses: part 2*. Academic Press, New York, USA.
- LINDEMAN, J.C. AND MENNEGA, A.M.W., 1963. *Bomenboek voor Suriname*. Suriname Forest Service, Paramaribo, Suriname.
- LINDEMAN, J.C. AND MOOLENAAR, S.P., 1959. Preliminary survey of the vegetation types of northern Suriname. (The vegetation of Suriname I, Part 2). Van Eedenfonds, Amsterdam, The Netherlands.
- LÖFFLER, H.J., 1981. Land qualities and forest operations. in Laban, P. (ed.). *Proceedings of the workshop on land evaluation for forestry*. IUFRO/ISSS, Wageningen, The Netherlands.
- LÖFFLER, H.J., 1984. *Terrain classification for forestry*. The Joint Committee on Forest Working Techniques and Training of Forest Workers, Izmir-Cesme, Turkey.
- LUNING, H.A., 1987. The need for tropical rain forests and their products. in Beusekom, C.F. van, Goor, C.P. van and Schmidt, P. (eds). *Wise utilization of tropical rain forest lands*. (Tropenbos Scientific Series 1). The Tropenbos Programme, Ede, The Netherlands.

- McGONAGILL, K.L., 1978. Logging systems guide. USDA Forest Service, Juneau, Alaska.
- MCKENZIE, T.A., 1981. The implementing of regional development activities critical in Suriname forestry. National Planning Foundation, Paramaribo, Suriname.
- MEIJENFELDT, C.F.W.M. VON, 1985. Gebruik van en alternatieven voor tropisch hout. Ministerie van Volkshuisvesting Ruimtelijke Ordening en Milieubeheer, The Hague, The Netherlands.
- MELLGREN, P.G. AND HEIDERSDORF, E., 1984. FERIC. (Technical Report 57). Forest Engineering Research Institute of Canada, Vancouver, Canada.
- MELLINK, W.H.H., 1981. Velschade in Surinaams drooglandbos. (Unpublished M.Sc. thesis). Wageningen Agricultural University, The Netherlands.
- MILDE, R. DE AND INGLIS, G.J., 1974a. Inventory of the Fallawatra, Nassau and Kabalebo area. (Project Working Document 13). FAO, Rome, Italy.
- MILDE, R. DE AND INGLIS, C.J., 1974b. Defect assessment of standing trees. (Project working document 14). FAO, Rome, Italy.
- MILES, J.A., HARTSOUGH, B.R., AULANI, P. AND CHANCELLER, W.J., 1981. A soil compaction study on the Blagett Experimental Forest. in Proceedings of the symposium on engineering systems for forest regeneration. American Society of Agricultural Engineers, Michigan, USA.
- MOEHRING, D.M. AND RAWLS, I.W., 1970. Detrimental effects of wet weather logging. *Journal of Forestry*, **68**, 166-167.
- MOERLAND, J., 1984. Suriname. (Landendocumentatie 1984-1). Koninklijk Instituut voor de Tropen, Amsterdam, The Netherlands.
- MYERS, N., 1981a. Deforestation in the tropics: who gains, who loses? in Sutlive, V.H., Althuler, N. and Zamora, M.D. (eds), *Where have all the flowers gone?* College of William and Mary, Williamsburg, USA.
- MYERS, N., 1981b. The hamburger connection: how Central America's forests become North America's hamburgers. *Ambio*, **10**, 3-8.
- NEIL, P.E., 1981. Problems and opportunities in tropical rain forest management. (CFI Occasional Papers 16). Commonwealth Forestry Institute, Oxford, United Kingdom.
- NICHOLSON, D.I., 1979. The effects of logging and treatment on the mixed Dipterocarp forests of South East Asia. FAO, Rome, Italy.
- NICHOLSON, D.I., RUDDER, H.N.B., AND ANDERSON, T.M., 1983. Research basis of rain forest management in north Queensland. 15th Pacific Science Congress, Dunedin, New Zealand.
- NIPKOW, F., 1983. Vorteile von Breitreifen für Forstschlepper auf schlecht tragfähigen Waldböden. *Forstwissenschaftliches Centralblatt*, **102**, 126-142.
- NOELMANS, P.L., 1979. Voorbereiding Houtverwerkingsbedrijf Mapane, Bosexploitatieplan Hardhoutareaal. ILACO/Suriname Forest Service, Paramaribo, Suriname.
- OESTERHOLT, J.M., 1986. Winch systems and short-wood logging. (Unpublished M.Sc. thesis). Wageningen Agricultural University, The Netherlands.
- OLDEMAN, R.A.A., 1983. Tropical rain forest, architecture, silvigenesis and diversity. in Sutton, S.L., Whitmore, T.C. and Chadwick, A.C. (eds), *Tropical rain forest: ecology and management*. Blackwell Scientific Publications, Oxford, United Kingdom.
- OLDEMAN, R.A.A., 1987. Tropical forest: the ecosystems. in Beusekom, C.F. van, Goor, C.P. van and Schmidt, P. (eds), *Wise utilization of tropical rain forest*

- lands. (Tropenbos Scientific Series 1). The Tropenbos Programme, Ede, The Netherlands.
- OSMASTON, F.C., 1968. The management of forests. George Allen and Unwin Ltd. London, United Kingdom.
- OTT, L., 1984. An introduction to statistical methods and data analysis. PWS Publishers, Boston, USA.
- PFEIFFER, J. Ph., 1926. *De houtsoorten van Suriname*. (KVKI Mededelingen 22). KVKI, Amsterdam, The Netherlands.
- PFEIFFER, J.Ph., 1929. Rapport aangaande de wijze waarop de Regering in Nederland en het Gouvernement van Suriname in de toekomst werkzaam zullen kunnen zijn ter bevordering van de houtuitvoer van Suriname. Algemene Landsdrukkerij, The Hague, The Netherlands.
- PLASSCHAERT, E.K., 1910. *Der Forstbetrieb in Suriname*. Kastner und Callwey, München, Germany.
- POELHEKKE, F.G.M.N., 1984. Prikkeldraad in het oerwoud: de veeteelt in het proces van economische en sociale integratie van het Amazonegebied in Brazilië. (Thesis). University of Nijmegen, The Netherlands.
- POELS, R.L.H., 1987. Soils, water and nutrients in a forest ecosystem in Suriname. (Ecology and management of tropical rain forests in Suriname 2). Wageningen Agricultural University, The Netherlands.
- PULLE, A., 1906. An enumeration of the vascular plants from Suriname. (Thesis). University of Leiden, The Netherlands.
- PUTZ, F.E., 1984. The natural history of lianas on Barro Colorado Island, Panama. *Ecology*, **65**, 1713-1724.
- QUEENSLAND DEPARTMENT OF FORESTRY, 1983. Rain forest research in North Queensland. Queensland Department of Forestry, Brisbane, Australia.
- REPETTO, R. AND GILLIS, M. (EDS), 1988. Public policies and misuse of forest resources. Cambridge University Press, New York, USA.
- RICHARDS, P.W., 1964. The tropical rain forest. Cambridge University Press, United Kingdom.
- ROLLET, B., 1974. L'architecture des forêts denses humides sempervirentes de plaine. Centre Technique Forestier Tropical, Nogent sur Marne, France.
- ROLLET, B., 1978. Organization. in UNESCO, Tropical Forest Ecosystems. (Natural resources research XIV). United Nations Educational, Scientific and Cultural Organization, Paris, France.
- SANKTJOHANSER, L., 1985. Bemühungen um eine waldschonende Holzernte in Deutschland. *Allgemeine Forstzeitung*, **96**, 304-307.
- SCHMIDT, P. IN PRESS. Ecology of managed tropical rain forest in Suriname. (Ecology and management of tropical rain forests in Suriname). (Provisional title). Wageningen Agricultural University, The Netherlands.
- SCHMIDTHÜSEN, F.J., 1974. Forestry development in Suriname: forest legislation. FAO/Suriname Forest Service, Paramaribo, Suriname.
- SCHULZ, J.P., 1960. Ecological studies on rain forests in northern Suriname. Noord-Hollandse Uitgevers Maatschappij, Amsterdam, The Netherlands.
- SCHULZ, J.P., 1967. La regeneración natural de la selva mesofítica tropical de Surinam después de su aprovechamiento. (Boletín del Instituto Forestal Latino-Americano de Investigación y Capacitación 23). IFLAIC, Mérida, Venezuela.
- SIN MENG SRUN, 1985. Tropical forest cover continues to disappear. *World Wood*, **26**, 17-19.
- SNEDECOR, G.W. AND COCHRAN, W.G., 1980. Statistical methods. Iowa State University Press, Ames, USA.

- SNLIJERS, W., 1953. Voorlopige bedrijfsplan voor de concessie Atjeh. Suriname Forest Service, Paramaribo, Suriname.
- SOANE, B.D., BLACKWELL, P.S., DICKSON, J.W. AND PAINTER, D.J., 1981a. Compaction by agricultural vehicles: a review. Part I: Soil and wheel characteristics. *Soil and Tillage Research*, 1, 207-237.
- SOANE, B.D., BLACKWELL, P.S., DICKSON, J.W. AND PAINTER, D.J., 1981b. Compaction by agricultural vehicles: a review. Part II: Compaction under tyres and other running gear. *Soil and Tillage Research*, 1, 373-400.
- STAAF, K.A.G. AND WIKSEN N.A., 1984. *Tree Harvesting Techniques*. Martinus Nijhoff, Dordrecht, The Netherlands.
- STEEGE, J.G. VAN DER, 1983. Studiekartering van het Mapane-proefgebied van het CELOS-project te Suriname. (Unpublished M.Sc. thesis). Wageningen Agricultural University, The Netherlands.
- SUDAM, 1977. Exploracao Mecanizada de Floresta em Terra Firma, Belem. (PNUD/FAO/IBDF/BRA-76/027 Publication). SUDAM, Belem, Brasil.
- SUNDBERG, U. AND SILVERSIDES, C.R., 1988. Operational Efficiency in Forestry. Volume 1: Analysis. Kluwer Academic Publishers, Dordrecht, The Netherlands.
- SUNDBERG, U. AND SILVERSIDES, C.R., 1989. Operational Efficiency in Forestry. Volume 2: Practices. Kluwer Academic Publishers, Dordrecht, The Netherlands.
- SYNNOTT, T.J., 1979. A manual of permanent plot procedures for tropical rain forests. (Tropical Forestry Papers 14). Commonwealth Forestry Institute, Oxford, United Kingdom.
- TINAL, U. AND PALENEWEN, J.L., 1974. A study of mechanical logging after selective cutting in the lowland Dipterocarp forest at Beloro, East Kalimantan. BIOTROP, Bogor, Indonesia.
- TJON LIM SANG, R., IN PRESS. Secondary succession on evergreen seasonal forest in Suriname. (Ecology and management of tropical rain forests in Suriname). [Provisional title]. Wageningen Agricultural University, The Netherlands.
- TRAA, A. VAN, 1946. Suriname 1900-1940. W. van Hoeve, Deventer, The Netherlands.
- ULRICH, B., 1983. A concept of forest ecosystem stability and of acid deposition as driving force for destabilization. in Ulrich, B. and Pankrath, J. (eds), *Effects of accumulation of air pollutants in forest ecosystems*. D. Reidel Publishing Company, Dordrecht, The Netherlands.
- UNESCO, 1978. *Tropical forest ecosystems*. (Natural resources research XIV). United Nations Educational, Scientific and Cultural Organization, Paris, France.
- VIERHOUT, J., 1983. Physical degradation of yellow kaolinitic oxisols of the Zanderij formation in Suriname. (CELOS rapporten 139). CELOS, Paramaribo, Suriname.
- VINK, A.T., 1964a. Forestry in Suriname: National Progress Report 1960-1964 presented to the 9th session of the Latin American Forestry Commission. Suriname Forest Service, Paramaribo, Suriname.
- VINK, A.T., 1964b. Some notes on yield regulation and stand improvement in the Mapane high forest. Suriname Forest Service, Paramaribo, Suriname.
- VINK, A.T., 1965. Surinam timbers. Suriname Forest Service. Paramaribo, Suriname.
- VINK, A.T., 1970. Forestry in Suriname: a review of policy, planning, projects and progress. Suriname Forest Service, Paramaribo, Suriname.



- VLETTER, J. DE, 1980. Voorstel praktijkproef natuurlijke verjonging te Mapane. Suriname Forest Service, Paramaribo, Suriname.
- VOOREN, A.P., 1987. Development versus forest conservation: avoiding a conflict in the Tai region (Ivory Coast). in Beusekom, C.F. van, Goor, C.P. van and Schmidt, P. (eds), Wise utilization of tropical rain forest lands. (Tropenbos Scientific Series 1). The Tropenbos Programme, Ede, Wageningen.
- WARDLE, P.A., 1974. Forestry development in Suriname: economics studies carried out in reviewing the potential contribution of forest industries to the economy. FAO/Suriname Forest Service, Paramaribo, Suriname.

# APPENDIX I

## Notes on Suriname

### I.1 Geography

Suriname is the middle country of the three Guyanas on the northern coast of South America. In the humid tropics between 2° and 6° north latitude and 54° and 58° west longitude, the country is 16.3 million hectares in area. The Marowijne River forms the border with French Guyana in the east and in the west, the country is separated from Guyana by the Corantijn River. The southern border with Brazil is partly formed by mountains, the watershed limit between the northern rivers and the affluents of the Amazon (Fig. 1.1).

The two border rivers and four other major rivers connect the hilly interior with the coastal plain. The development of Suriname started along these waterways when it was colonized in the 17th century. Although limited in navigability by rapids and falls, rivers are the main means to transport raw materials. The main rivers on the coastal plain are connected by numerous tributaries which provide a traffic network from east to west. Rivers are also important for industrial development especially for wood-based industries. Most of the commercial sawmills in the coastal area are located along the navigable parts of the large rivers.

### I.2 Geology and landforms

From the sea coast consisting mainly of mudbanks to the southern border with Brazil, the following geological zones are found (Fig. I.1):

- young coastal plain or Demerara formation;
- old coastal plain or Coropina formation;
- Zanderij landscape or Coesewijne formation;
- old basement complex or Guyana shield.

The landscape of young coastal plain is flat, partly below sea level, and with poor

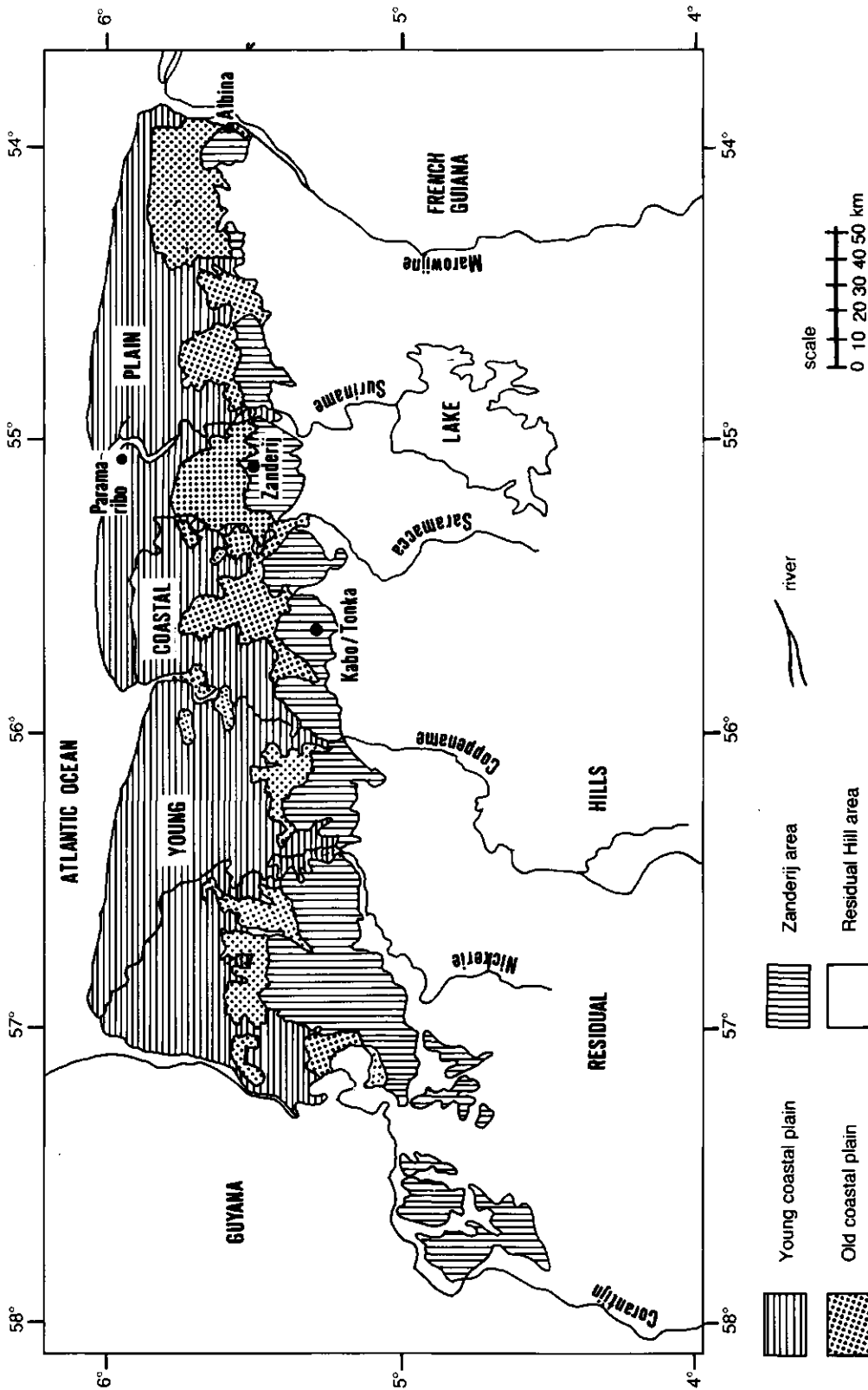


Fig. 1.1 Geological map of northern Suriname

natural drainage. It is an east-west belt of originally freshwater swamps covered with either herbaceous vegetation or forest. The soils are predominantly young clays and when drained are very suitable for rice cropping. Slightly elevated (up to 2 m above MSL) ridge formations, narrow strips of sands and sandy loams are very conspicuous in the inundated landscape.

The old coastal plain is a few metres above sea level. The soils are mainly sandy loams of low fertility. Compared with the young coastal plain, there are fewer swamps but about 20-30% of the soils is marshy. Dry parts, swamps and marsh ground form a typical eroded pattern.

The Zanderij formation is more sharply distinguished from the coastal plain. It is a coarse sand formation of old sediments, composed of mainly bleached white quartz sands or unbleached sands and sandy clays. The open areas of bleached sands are referred to as savannahs (Cohen and van der Eyk, 1953). The soil type is often reflected in the forest vegetation. Three types of forest are distinguished; xerophytic, low forest or high forest vegetation. The landscape is flat to undulating becoming more hilly in the south. The mean altitude is about 40 m above sea level.

The remaining 70% of the country is in the Guyana shield formation of old residual soils of Praecambian origin. Most of this zone is covered with high forest. The landscape, which is dissected by hundreds of creeks, is more hilly than mountainous with peaks up to 1250 m above MSL. The plateaus and slopes are covered with lateritic clays (Latosols), while the dominant soil types on the foot slopes and in the valleys are colluvial sands and loams. Along and in river and creek valleys, typical Fluvisols have been formed from alluvial deposits.

### **I.3 Climate**

According to the Köppen's classification the climate of Suriname is tropical. The mean annual temperature is 26°C with a daily amplitude of 8°C. Lowest temperatures of 18°C have been recorded in the short dry season on interior plateaus (Schulz, 1960). The coolest months are January and February, and the warmest September and October. Although the relative humidity is high (80%), the climate in the coastal plain is comfortable because of the north-east trade-wind.

The rainfall is high, between 1700 and 2500 mm/y, gradually decreasing from the interior to the north-west coast. There are two rainy seasons, the main one from April to August and a short rainy season from December to January. There are also two dry seasons, one in August to November and the other from February to March. However, this seasonal pattern is not sharp, a dry month in Suriname may still have a rainfall of more than 60 mm.

## I.4 Forest vegetation

Almost 90% (14.4 million ha) of the country is covered with forest. Mangrove forests are found along the sea coast and in the young coastal plain along banks of the large rivers (van Dillewijn, 1957; Lindeman and Moolenaar, 1959). Other hygrophytic vegetation types, such as freshwater swamp and marsh forests, are found on periodically flooded areas in the coastal plain. Further to the south the Zanderij formation and the old basal complex are covered with dense rain forest and extend over most (82%) of the country (Table I.1). The rain forest is the most important resource for timber production although for years substantial quantities have been supplied to the local wood processing industry and to export markets from the swamp and marsh forests.

As in many tropical countries, forest accessibility is a major problem. Rapids and falls in the major rivers inhibit transport. The hilly terrain particularly in the south also impedes access. Thus forestry activities are largely restricted to the high forest in the north of Suriname. This region is known as the exploitable forest belt (Vink, 1970) or Forestry Belt (de Graaf, 1986).

TABLE I.1. Forest types with regard to timber production

| Forest type             | Location                                     | Area (%) <sup>*</sup> | Annual coupe (m <sup>3</sup> ) | Common species   |
|-------------------------|--|-----------------------|--------------------------------|--|
| Mangrove forest         | sea coast                                    | 1.0                   | n.a.**                         | <i>Rhizophora spp.</i><br><i>Avicennia nitida</i>  |
| Freshwater swamp forest | young coastal plain, along creeks and rivers | 5.0                   | 3 000                          | <i>Virola surinamensis</i><br><i>Triplaris surinamensis</i><br><i>Symphonia globulifera</i>  |
| Marsh forest            | old coastal plain, along creeks and rivers   | 2.0                   | 4 000                          | <i>Carapa guianensis</i><br><i>Mora excelsa</i><br><i>Hura crepitans</i>   |
| Savannah forest         | Zanderij formation                           | 1.0                   | 10 000                         | <i>Eperua falcata</i>  |
| Mesophytic rain forest  | old basal complex, Zanderij formation        | 78.0                  | 300 000                        | <i>Dicorynia guianensis</i><br><i>Goupia glabra</i><br><i>Licaria guianensis</i><br><i>Ocotea rubra</i><br><i>Vouacapoua americana</i><br><i>Qualea spp.</i> |

Source: LBB Statistics

\* Proportion of total land area

\*\* Occasionally harvested for fishery timber

The Forestry Belt is a zone of high forest, 10-40 km wide, extending from east to west, including the Zanderij formation and the northern hills of the old basal complex (Fig. I.1). It is an area of 1.5 million ha of which 600 000 ha are considered to be productive forest. The Forest Service road building programme (1955 to 1980) has made this area accessible. Almost 2000 km of gravel roads have been constructed by the Forest Service and a further 400 km by private companies.

The Forestry Belt supplies 90% of all forest products. An area of 6000 ha of exploited forest has been released for oil palm plantations. The Forestry Belt which also includes 8000 ha of forest plantations is the heart of all present and future forestry activities (ILACO, 1977; INFORSON, 1979).

### **I.5 Population and Economy**

The present population of Suriname is approximately 385 000 inhabitants, giving a population density of 2.4 per km<sup>2</sup>. The population is very unevenly distributed: 85% is concentrated in the coastal plain around the capital city, Paramaribo, and the towns of Nw. Nickerie and Moengo. Easy access, availability of agricultural land and the development of the mining industry in the first half of this century, are the reasons for this concentration.

Until the first half of the 18th century, Suriname was a prosperous Dutch colony producing tropical foods for the world market. The agricultural system was based on the labour of African slaves, who were employed on the large plantations along the main rivers. The economic system collapsed before the abolition of slavery in 1863. Contract labourers from Asia in the period 1873-1939 did not reverse the trend and brought transfer to small-scale private farms. The colony remained agrarian, but was no longer a principal producer of selected products for the world market. The introduction of rice and other crops has brought more diversity and stability to agricultural production. Suriname's economy changed dramatically after the Second World War when bauxite became the main export. The mining industry became the cornerstone of the economy, especially after the construction of a hydropower plant and aluminium factory in 1959-1961 (Essed, 1973). Its contribution to the gross domestic product is 30%, to the employment 8% and to foreign exchange 80%. Suriname is still a producer of raw material for a world market and the economy still depends on a single product and is thus similar to the plantation economy of the past.

The second mainstay in the country's economy was until recently the development aid. Increased substantially over the period 1947 to 1982, this aid has had considerable influence on Suriname's socio-economic development. Since its establishment in 1955, the government Planning Board Foundation has been responsible for development planning and control. In 1965 the first development strategy was formulated in the National Development Plan. The major objectives were to increase gross domestic product and employment and to create diversity in produc-

tion. The agrarian and wood-based industry were to be developed with the aim of reducing the dependence on the (mono) mining industry. To this end, a substantial amount of approximately one billion Suriname guilders (US\$1 = Sf 1.80) has been invested since 1947.

Since the re-establishment of the Suriname Forest Service in 1947 forestry has been given greater priority in government policy. In the past 30 years considerable investments has been made in forest inventory, tree plantations, road building and other forestry development projects. This policy has resulted in improvement and extension of the logging and wood-based industry and in growing public interest and appreciation of the forestry sector. Of minor interest in the first half of the century, timber exports have increased rapidly since the Second World War. In spite of these developments, the forestry sector contributes relatively little to the national economy. The sector's contribution to exports, gross domestic product and employment is 3% (Moerland, 1984). The Gross National Product (GNP), which was US\$ 8500 per capita in 1982, has decreased substantially in the last few years.

## APPENDIX II

### Forest exploitation in wet lands

#### II.1 Swamp forest exploitation

In the 1960s, swamp forests were the most important suppliers of peeler logs for Suriname's plywood plant. Annually, more than 20 000 m<sup>3</sup> of baboen (*Virola surinamensis*) logs were harvested and transported to Paramaribo (LBB Statistics). Baboen stands are located along rivers and in fresh water swamps of the coastal plain. These stands were exploited commercially by Bruynzeel Suriname Houtmaatschappij (BSH) in the Cottica, Suriname and Coesewijne River basins, where swamps were made accessible by a canal system.

Swamp forests are difficult to harvest. For most of the year the swamp is inundated and even in the dry season the soil is too wet for mechanized logging. Swamps only dry up completely in extremely dry years. The productive swamp forest is characterized by two storeys with a height of 30 to 40 m. The upper storey is dominated by a few timber species, such as baboen (*Virola surinamensis*) and matakki (*Symphonia globulifera*); which often grow on the higher sites of the swamps, on ridges and on river banks (van Dillewijn, 1957).

The baboen swamp forest has been opened by an artificial canal system. The first canals were blasted with dynamite (Bubberman and Vink, 1966) but later were dug with hydraulic backhoes. The main canal is east-west oriented, perpendicular to the river, 3 m wide and 1.5 m deep. Secondary ditch branches are 2 m wide and 1 m deep, north-south oriented and 1 km apart. The whole system is connected to the river by the main canal with a connecting lock of an earthen dam. The canals are an excellent transportation network for labour, equipment and logs.

Trees were felled with chain saws, bucked into short lengths (2.5 and 5.0 m) and skidded to the ditch branches by a cable yarder over distances up to 500 m. For this purpose, the forest is slightly opened by narrow skid trails. As *Virola* logs are floatable, they are grouped together in small rafts for further transport to the river terminal. These rafts are conveniently floated in manual power or pulled by a small outboard motorboat. At the collecting point at the end of the canal, the logs are pulled across the dam into the river by a fixed yarder. Larger rafts are made in the



river for the final transport to Paramaribo with the aid of a tugboat.

During the first years of the swamp exploitation, crawler tractors were used to transport logs to the ditches. The tractors were equipped with 60 cm wide tracks for travelling on soft soils; they were able to operate on the ridges and banks in the swamps. Because of high maintenance cost their use in swamp forest exploitation was discontinued.

About 200 km of canals has been constructed giving access to approximately 30 000 ha of baboen forest in the three different areas (Cottica, Coesewijne and Suriname swamps). In the 1960s and 1970s the stands were creamed off rapidly taking away the most accessible stock and leaving behind the more scattered trees. The mechanized logging set-up was expensive and wasteful because of the high maintenance costs of machinery and of poorly organized operations. This exploitation system has hastened depletion of the baboen stands. This process was accelerated by a fire in 1963, when thousands of hectares of good stands were completely destroyed (Bubberman, 1973).

At the end of 1982, extension of the canal system ceased. The remaining stands are now harvested by contractors and no longer by BSH. All operations, even ditch digging and maintenance, are manual. Logs are rolled from the stump into the swamp water and then pulled to the canals. They are delivered in the Coesewijne River grouped to rafts for a cost of US\$ 15.00 per m<sup>3</sup>, which is far below BSH own costs levels. Annual production is just 2500 m<sup>3</sup>, but this extensive exploitation can probably be continued for many more years. The current working method proves that manual exploitation is better adapted to the swamp environment and cheaper than mechanized methods even in a country like Suriname where wages are higher than in most tropical countries. No indications were found that the working environment is less safe than for mechanized exploitation, but the long term effects on workers health are not known.

## II.2 Marsh forest exploitation

A number of hygrophytic forest types can be classified as marsh forest, a two-storied and 15-30 m high forest with irregular canopy, found on periodically flooded grounds in the coastal plain, river levees and creek valleys (Lindeman and Moolenaar, 1959). Forest exploitation is practically limited to krapa wood (*Carapa spp.*) and occasionally to species such as mora (*Mora exselsa*), groenhart (*Tabebuia serratifolia*), manbarklak (*Eschweilera spp.*) and possum (*Hura crepitans*). For decades, krapa logs were exported to Guyana in quantities of 10 000 to 15 000 m<sup>3</sup> annually. Since 1977 export has ceased due to Governmental measures in Guyana but also because of depletion of accessible krapa stands.

The best krapa stands were found along the Corantijn river in West Suriname. Logs were skidded with buffaloes and agricultural tractors. The logging methods

were very damaging because skid trails were constructed as corduroid paths with young trees and poles.

Possum (*Hura crepitans*) forests on river banks and ridges were harvested in the past, but nowadays are of minor interest because access to the remaining stands is difficult. Mora forests, which are still abundantly available on the banks of the Saramacca, Coppename and Corantijn Rivers were exploited temporarily. About 50 000 m<sup>3</sup> mora wood were harvested for sleepers for a railway in West Suriname. These activities ceased in 1980.

# APPENDIX III

## CELOS list of commercial species

| Family        | Scientific name  | Vernacular name          | Trade name  |
|---------------|--|--------------------------|-------------|
| Anacardiaceae | <i>Loxopterygium sagotii</i>   | slangenhout              |             |
| Annonaceae    | <i>Xylopia aromatica</i> ; <i>X. nitida</i>                            | pegrekoepisi             |             |
| Araliaceae    | <i>Schefflera decaphylla</i><br>(syn.: <i>S. paraënsis</i> )           | morototo                 |             |
|               | <i>Schefflera morototoni</i><br>(syn.: <i>Didymopanax morototoni</i> ) | kassavehout              | morototo    |
| Bignoniaceae  | <i>Jacaranda copaia</i>  | goebaja                  | futui       |
|               | <i>Tabebuia serratifolia</i>   | groenhart                | tabebuia    |
| Burseraceae   | <i>Protium insigne</i>   | grootbladige tingimoni   | kurokai     |
|               | <i>Protium neglectum</i>   | harde bast tingimoni     | kurokai     |
|               | <i>Tetragastris altissima</i>  | rode sali                |             |
|               | <i>Tetragastris hostmannii</i>   | tingimonisali            |             |
|               | <i>Trattinickia burserifolia</i> ;<br><i>T. rhoifolia</i>              | ajawatingimoni           |             |
| Goupiaceae    | <i>Goupia glabra</i>   | kopi                     | goupie      |
| Guttiferae    | <i>Platonia insignis</i> ;   | pakoeli                  | pakuri      |
|               | <i>Rheedia benthamiana</i>   |                          |             |
|               | <i>Symphonia globulifera</i>   | mataki                   | manni       |
| Humiriaceae   | <i>Humeria balsamifera</i>   | blakaberi                | tauroniro   |
| Lauraceae     | <i>Licaria canella</i><br>(syn.: <i>L. cayennensis</i> )               | kaneelhart               |             |
|               | <i>Nectandra grandis</i>   | zwarte grootbladige pisi | louro preto |
|               | <i>Ocotea globifera</i>  | wanapisi                 | louro preto |
|               | <i>Ocotea glomerata</i>  | zwarte kleinbladige pisi | louro preto |
|               | <i>Ocotea petalantha</i>   | witte pisi               | louro preto |
|               | <i>Ocotea rubra</i>  | wana                     | red louro   |

continued

| Family        | Scientific name  | Vernacular name     | Trade name  |
|---------------|--|---------------------|-------------|
| Lecythidaceae | <i>Lecythis zabucajo</i><br>(syn.: <i>L. davisii</i> )                 | kwatapatoe          |             |
| Leguminosae   | <i>Andira coriacea</i> ; <i>A. inermis</i> ;<br><i>A. surinamensis</i> | rode kabbes         | angelin     |
|               | <i>Dicorynia guianensis</i>  | basralokus          | angelique   |
|               | <i>Dipteropsis purpurea</i>  | zwarte kabbes       | tatabu      |
|               | <i>Dipterix odorata</i> ;<br><i>D. punctata</i>                        | tonka               | tonka       |
|               | <i>Hymenaea courbaril</i>  | rode lokus          | courbaril   |
|               | <i>Mora excelsa</i>  | mora                | mora        |
|               | <i>Parkia nitida</i>   | agrobigi            |             |
|               | <i>Peltogyne paniculata</i> ;<br><i>P. venosa</i>                      | purperhart          | purpleheart |
|               | <i>Platymiscium trinitatis</i> ;<br><i>P. ulei</i>                     | koenatepi           |             |
|               | <i>Vouacapoua americana</i>  | bruinhart           | wacapou     |
| Meliaceae     | <i>Carapa procera</i>  | krapa               | andiroba    |
|               | <i>Cedrela odorata</i>   | ceder               | cedar       |
| Moraceae      | <i>Brosimum paraëense</i>  | satijnhout          | satiné      |
|               | <i>Brosimum guianense</i><br>(syn.: <i>Piratinera guianensis</i> )     | letterhout          | snakewood   |
| Myristicaceae | <i>Virola melinonii</i>  | hoogland baboen     | baboen      |
|               | <i>Virola surinamensis</i>   | laagland baboen     | baboen      |
| Rutaceae      | <i>Fagara pentandra</i>  | pritiari            |             |
| Sapotaceae    | <i>Manilkara bidentata</i>   | bolletri            | balata      |
|               | <i>Micropholis guyanensis</i> var.<br><i>commixta</i>                  | zwart riemhout      |             |
|               | <i>Micropholis guyanensis</i> var.<br><i>guyanensis</i>                | wit riemhout        |             |
| Simaroubaceae | <i>Simarouba amara</i>   | soemaroeba          | simarouba   |
| Sterculiaceae | <i>Sterculia excelsa</i> ;<br><i>S. pruriens</i>                       | okerhout            | sterculia   |
| Vochysiaceae  | <i>Qualea albiflora</i>  | hoogland gronfoeloe | gronfoeloe  |
|               | <i>Qualea coerulea</i>   | laagland gronfoeloe | gronfoeloe  |
|               | <i>Qualea rosea</i>  | bergi gronfoeloe    | gronfoeloe  |
|               | <i>Vochysia guianensis</i>   | wiswiskwari         | kwarie      |
|               | <i>Vochysia tomentosa</i>  | wanakwari           | kwarie      |

Source: de Graaf (1986); Jonkers (1987).

# APPENDIX IV

## Inventory data and statistical tests

TABLE IV.1. Mapane research area: diameter class distribution of commercial and potential species in the Rama area (Concession 2) in 1982

| Species       | Frequencies (n/100 ha) per diameter class (cm dbh) |       |       |       |       |       |        |         |         |      | Total |
|---------------|--|-------|-------|-------|-------|-------|--------|---------|---------|------|-------|
|               | 35-45  | 45-55 | 55-65 | 65-75 | 75-85 | 85-95 | 95-105 | 105-115 | 115-125 | >125 |       |
| agrobigi      | 6.8  | 1.1   | 2.5   | 1.1   | 6.4   | 2.5   | 2.1    | 1.4     | 1.4     | 0.7  | 26.0  |
| baboen        | 2.8  | 16.1  | 7.1   | 4.6   | 2.5   | 0.7   | 0.0    | 0.0     | 0.0     | 0.0  | 33.8  |
| basralokus    | 53.2   | 35.0  | 13.6  | 7.5   | 2.9   | 2.5   | 0.0    | 0.4     | 0.4     | 0.7  | 116.2 |
| bolletri      | 0.0  | 0.0   | 0.0   | 0.0   | 0.0   | 0.0   | 0.0    | 0.0     | 0.0     | 0.0  | 0.0   |
| bruinhart     | 104.6  | 104.3 | 104.6 | 71.1  | 55.7  | 32.5  | 12.1   | 2.9     | 2.1     | 0.5  | 490.4 |
| ceder         | 0.4  | 0.4   | 0.0   | 0.0   | 0.0   | 0.0   | 0.0    | 0.0     | 0.0     | 0.0  | 0.8   |
| goebaja       | 20.7   | 8.9   | 0.7   | 0.4   | 0.0   | 0.0   | 0.0    | 0.0     | 0.0     | 0.0  | 30.7  |
| goejabakwari  | 2.5  | 1.4   | 1.8   | 1.1   | 0.3   | 0.7   | 0.4    | 0.5     | 1.1     | 1.4  | 11.2  |
| groenhart     | 1.4  | 2.1   | 2.5   | 0.7   | 0.6   | 0.0   | 0.0    | 0.5     | 0.0     | 0.0  | 7.8   |
| gronfoeloe    | 13.6   | 12.1  | 10.7  | 6.8   | 6.7   | 7.5   | 3.2    | 0.4     | 0.5     | 0.3  | 61.8  |
| koenatepi     | 3.9  | 1.1   | 0.4   | 0.7   | 0.0   | 0.0   | 0.0    | 0.0     | 0.0     | 0.0  | 6.1   |
| kopi          | 12.5   | 15.4  | 8.6   | 11.4  | 10.0  | 9.3   | 4.6    | 2.1     | 0.4     | 0.8  | 75.1  |
| krapa         | 75.4   | 22.5  | 4.6   | 0.4   | 0.0   | 0.0   | 0.0    | 0.0     | 0.0     | 0.0  | 102.9 |
| kromantikopi  | 3.2  | 1.1   | 1.4   | 0.5   | 0.3   | 0.0   | 0.0    | 0.0     | 0.0     | 0.0  | 6.5   |
| kwari         | 4.3  | 3.2   | 1.8   | 5.0   | 4.3   | 3.6   | 0.8    | 1.1     | 1.2     | 0.3  | 25.6  |
| kwatapatoe    | 3.6  | 3.2   | 3.5   | 3.6   | 4.6   | 7.1   | 3.2    | 1.8     | 0.7     | 0.4  | 31.7  |
| letterhout    | 10.0   | 4.3   | 1.1   | 1.0   | 0.0   | 0.0   | 0.0    | 0.0     | 0.0     | 0.0  | 16.4  |
| manletterhout | 17.6   | 6.8   | 1.4   | 0.0   | 0.4   | 0.0   | 0.0    | 0.0     | 0.0     | 0.0  | 26.2  |
| kassavehout   | 1.4  | 1.8   | 1.8   | 0.3   | 0.0   | 0.0   | 0.0    | 0.0     | 0.0     | 0.0  | 5.3   |
| okerhout      | 21.2   | 22.1  | 14.3  | 5.0   | 3.6   | 2.5   | 0.7    | 0.0     | 0.5     | 0.3  | 70.2  |
| pisi          | 35.0   | 17.5  | 7.9   | 1.8   | 1.4   | 0.4   | 0.3    | 0.0     | 0.0     | 0.0  | 64.3  |
| purperhart    | 2.5  | 2.9   | 1.1   | 0.5   | 0.2   | 0.0   | 0.0    | 0.0     | 0.0     | 0.0  | 7.2   |
| rode kabbes   | 1.4  | 2.5   | 2.9   | 3.2   | 1.1   | 2.1   | 0.0    | 0.0     | 0.0     | 0.0  | 13.2  |
| rode sali     | 143.9  | 77.1  | 26.4  | 11.8  | 4.3   | 1.8   | 0.0    | 0.0     | 0.0     | 0.0  | 265.3 |
| soemaroeba    | 4.6  | 2.9   | 3.9   | 1.4   | 0.7   | 0.6   | 0.0    | 0.0     | 0.4     | 0.5  | 15.0  |
| tingimoni     | 72.5   | 33.9  | 7.5   | 2.1   | 1.8   | 0.0   | 0.4    | 0.2     | 0.0     | 0.0  | 118.4 |
| tingimonisali | 35.0   | 15.0  | 6.8   | 1.8   | 0.4   | 0.0   | 0.0    | 0.0     | 0.0     | 0.0  | 59.0  |
| wana          | 6.1  | 6.8   | 2.1   | 0.8   | 1.4   | 0.7   | 1.4    | 0.0     | 0.0     | 0.2  | 19.3  |
| zwarte kabbes | 1.4  | 1.8   | 0.5   | 0.7   | 0.3   | 0.0   | 0.0    | 0.0     | 0.0     | 0.0  | 4.7   |

TABLE IV.2. Mapane research area: diameter class distribution of commercial and potential species in the Tibiti area (Concession 3) in 1982

| Species       | Frequencies (n/100 ha) per diameter class (cm dbh) |       |       |       |       |       |        |         |         |      | Total |
|---------------|--|-------|-------|-------|-------|-------|--------|---------|---------|------|-------|
|               | 35-45  | 45-55 | 55-65 | 65-75 | 75-85 | 85-95 | 95-105 | 105-115 | 115-125 | >125 |       |
| agrobigi      | 2.8  | 3.9   | 3.1   | 3.3   | 3.6   | 0.8   | 1.7    | 0.8     | 0.3     | 0.6  | 20.9  |
| baboen        | 53.3   | 32.2  | 14.4  | 3.6   | 1.1   | 0.0   | 0.3    | 0.0     | 0.0     | 0.0  | 104.9 |
| basralokus    | 28.3   | 25.3  | 12.8  | 5.8   | 1.9   | 0.8   | 0.4    | 0.2     | 0.3     | 0.3  | 76.1  |
| bolletri      | 3.1  | 3.9   | 3.9   | 3.6   | 2.2   | 1.7   | 0.8    | 0.3     | 0.0     | 0.0  | 19.5  |
| bruinhart     | 17.5   | 20.0  | 11.6  | 7.2   | 3.1   | 3.9   | 0.8    | 0.3     | 0.3     | 0.0  | 64.7  |
| ceder         | 2.2  | 1.1   | 1.4   | 1.1   | 0.0   | 0.0   | 0.0    | 0.0     | 0.0     | 0.0  | 5.8   |
| goebaja       | 25.8   | 10.8  | 3.6   | 0.8   | 0.0   | 0.0   | 0.0    | 0.0     | 0.0     | 0.0  | 41.0  |
| goejabakwari  | 4.7  | 2.5   | 1.7   | 4.2   | 2.2   | 4.4   | 2.2    | 1.1     | 0.3     | 1.1  | 24.4  |
| groenhart     | 9.4  | 12.8  | 10.3  | 8.3   | 4.2   | 4.7   | 0.6    | 0.6     | 0.0     | 0.3  | 51.2  |
| gronfoeloe    | 22.5   | 13.6  | 15.0  | 8.6   | 3.6   | 4.4   | 0.6    | 0.8     | 0.6     | 0.3  | 70.0  |
| koenatepi     | 6.4  | 3.9   | 1.4   | 0.3   | 0.0   | 0.5   | 0.0    | 0.0     | 0.0     | 0.0  | 12.5  |
| kopi          | 10.6   | 6.6   | 9.7   | 10.0  | 11.7  | 10.6  | 4.2    | 2.2     | 1.9     | 1.9  | 69.4  |
| krapa         | 133.6  | 41.9  | 6.4   | 0.5   | 0.0   | 0.0   | 0.0    | 0.0     | 0.0     | 0.0  | 182.4 |
| kromantikopi  | 3.1  | 1.4   | 0.6   | 0.5   | 0.0   | 0.0   | 0.0    | 0.0     | 0.0     | 0.0  | 5.6   |
| kwari         | 7.5  | 7.8   | 7.2   | 5.8   | 3.6   | 3.9   | 3.3    | 1.1     | 0.3     | 2.2  | 42.7  |
| kwatapatoe    | 0.8  | 1.4   | 2.2   | 1.1   | 0.6   | 0.5   | 0.6    | 0.3     | 0.0     | 0.8  | 8.3   |
| letterhout    | 14.4   | 5.5   | 1.7   | 0.7   | 0.0   | 0.2   | 0.0    | 0.0     | 0.0     | 0.0  | 22.5  |
| manletterhout | 1.7  | 2.5   | 0.3   | 0.0   | 0.0   | 0.0   | 0.0    | 0.0     | 0.0     | 0.0  | 4.5   |
| kassavehout   | 26.9   | 21.9  | 12.8  | 7.5   | 5.8   | 1.7   | 0.4    | 0.2     | 0.5     | 0.0  | 77.7  |
| okerhout      | 46.7   | 24.4  | 12.5  | 6.7   | 2.5   | 1.4   | 1.1    | 0.0     | 0.2     | 0.5  | 96.0  |
| pisi          | 0.6  | 0.3   | 0.2   | 0.0   | 0.0   | 0.0   | 0.0    | 0.0     | 0.0     | 0.0  | 1.1   |
| purperhart    | 3.1  | 3.9   | 3.6   | 1.4   | 2.2   | 0.0   | 0.5    | 0.0     | 0.0     | 0.0  | 14.7  |
| rode kabbes   | 6.7  | 7.5   | 5.6   | 1.1   | 0.8   | 0.0   | 0.0    | 0.0     | 0.0     | 0.0  | 21.7  |
| rode sali     | 234.4  | 106.7 | 39.7  | 16.9  | 4.4   | 1.4   | 0.3    | 0.0     | 0.0     | 0.0  | 403.8 |
| soemaroeba    | 116.7  | 35.3  | 6.9   | 2.8   | 0.8   | 0.2   | 0.3    | 0.7     | 0.5     | 0.6  | 164.8 |
| tingimoni     | 13.3   | 6.4   | 1.1   | 0.6   | 0.0   | 0.0   | 0.0    | 0.0     | 0.0     | 0.0  | 21.4  |
| tingimonisali | 8.6  | 6.4   | 1.7   | 1.1   | 3.3   | 1.1   | 0.8    | 0.6     | 0.4     | 0.5  | 24.5  |
| wana          | 3.1  | 1.7   | 0.6   | 0.5   | 0.2   | 0.0   | 0.0    | 0.0     | 0.0     | 0.0  | 6.1   |

TABLE IV.3. Mapane research area: diameter class distribution of commercial and potential species in the Rama (Concession 2) and Tibiti (Concession 3) area in 1982

| Species       | Total number of trees per diameter class (cm dbh)* |       |       |       |       |       |        |         |         |       | Total |
|---------------|--|-------|-------|-------|-------|-------|--------|---------|---------|-------|-------|
|               | 35-45  | 45-55 | 55-65 | 65-75 | 75-85 | 85-95 | 95-105 | 105-115 | 115-125 | > 125 |       |
| agrobigi      | 29   | 17    | 18    | 15    | 31    | 10    | 12     | 7       | 5       | 4     | 148   |
| baboen        | 270  | 161   | 72    | 26    | 11    | 2     | 1      | 0       | 0       | 0     | 543   |
| basralokus    | 251  | 189   | 84    | 42    | 15    | 10    | 1      | 2       | 2       | 3     | 599   |
| bolletri      | 11   | 14    | 14    | 13    | 8     | 6     | 3      | 1       | 0       | 0     | 70    |
| bruinhart     | 356  | 364   | 335   | 225   | 167   | 105   | 37     | 9       | 7       | 1     | 1606  |
| ceder         | 9  | 5     | 5     | 4     | 0     | 0     | 0      | 0       | 0       | 0     | 23    |
| goebaja       | 151  | 64    | 15    | 4     | 0     | 0     | 0      | 0       | 0       | 0     | 234   |
| gojabakwari   | 24   | 13    | 11    | 18    | 9     | 18    | 9      | 5       | 4       | 8     | 119   |
| groenhart     | 38   | 52    | 44    | 32    | 17    | 17    | 2      | 3       | 0       | 0     | 205   |
| gronfoeloe    | 119  | 83    | 84    | 50    | 32    | 37    | 11     | 4       | 3       | 2     | 425   |
| koenatepi     | 34   | 17    | 6     | 3     | 0     | 2     | 0      | 0       | 0       | 0     | 62    |
| kopi          | 73   | 67    | 59    | 68    | 70    | 64    | 28     | 14      | 8       | 9     | 460   |
| krapa         | 692  | 214   | 36    | 3     | 0     | 0     | 0      | 0       | 0       | 0     | 945   |
| kromantikopi  | 20   | 8     | 6     | 3     | 1     | 0     | 0      | 0       | 0       | 0     | 38    |
| kwari         | 39   | 37    | 31    | 33    | 25    | 24    | 14     | 7       | 4       | 9     | 223   |
| kwatapatoe    | 13   | 14    | 18    | 14    | 15    | 22    | 11     | 6       | 2       | 4     | 119   |
| letterhout    | 46   | 24    | 5     | 4     | 1     | 0     | 0      | 0       | 0       | 0     | 80    |
| manletterhout | 101  | 39    | 10    | 2     | 1     | 1     | 0      | 0       | 0       | 0     | 154   |
| kassavehout   | 10   | 14    | 6     | 1     | 0     | 0     | 0      | 0       | 0       | 0     | 31    |
| okerhout      | 156  | 141   | 86    | 41    | 31    | 13    | 3      | 1       | 3       | 1     | 476   |
| pisi          | 266  | 137   | 67    | 29    | 13    | 6     | 5      | 0       | 1       | 2     | 526   |
| purperhart    | 9  | 9     | 4     | 1     | 1     | 0     | 0      | 0       | 0       | 0     | 24    |
| rode kabbes   | 15   | 21    | 23    | 14    | 11    | 6     | 2      | 0       | 0       | 0     | 92    |
| rode sali     | 1247   | 600   | 217   | 94    | 28    | 10    | 1      | 0       | 0       | 0     | 2197  |
| soemaroeba    | 37   | 35    | 31    | 8     | 5     | 2     | 0      | 0       | 1       | 1     | 120   |
| tingimoni     | 623  | 222   | 46    | 16    | 8     | 1     | 2      | 3       | 2       | 2     | 925   |
| tingimonisali | 146  | 65    | 23    | 7     | 1     | 0     | 0      | 0       | 0       | 0     | 242   |
| wana          | 48   | 42    | 12    | 6     | 16    | 6     | 7      | 2       | 1       | 3     | 143   |
| zwarte kabbes | 15   | 11    | 3     | 4     | 2     | 0     | 0      | 0       | 0       | 0     | 35    |
| total         | 4848   | 2679  | 1371  | 780   | 519   | 362   | 149    | 64      | 43      | 49    | 10864 |

\* On 640 ha (64 units of 10 ha)

TABLE IV.4. Mapane research area: spatial distribution by diameter class of bruinhart trees in the Rama area (Concession 2) in 1982

| Inventory unit (no) | Number of trees per diameter class (cm dbh) per inventory unit of 10 ha |       |       |       |       |       |        |         |         |      | n/ha |
|---------------------|---|-------|-------|-------|-------|-------|--------|---------|---------|------|------|
|                     | 35-45   | 45-55 | 55-65 | 65-75 | 75-85 | 85-95 | 95-105 | 105-115 | 115-125 | >125 |      |
| 1                   | 6   | 8     | 22    | 19    | 14    | 3     | 0      | 1       | 0       | 0    | 7.3  |
| 2                   | 3   | 3     | 6     | 0     | 4     | 1     | 0      | 0       | 0       | 0    | 1.7  |
| 3                   | 12  | 22    | 16    | 11    | 15    | 8     | 3      | 1       | 1       | 0    | 8.9  |
| 4                   | 18  | 24    | 15    | 16    | 10    | 3     | 1      | 0       | 0       | 0    | 8.7  |
| 5                   | 38  | 32    | 27    | 16    | 9     | 7     | 3      | 0       | 1       | 0    | 13.3 |
| 6                   | 4   | 2     | 5     | 3     | 1     | 2     | 0      | 0       | 0       | 0    | 1.7  |
| 7                   | 15  | 8     | 17    | 8     | 5     | 5     | 0      | 0       | 0       | 0    | 5.8  |
| 8                   | 22  | 16    | 11    | 6     | 6     | 6     | 2      | 0       | 0       | 0    | 6.9  |
| 9                   | 4   | 13    | 11    | 15    | 9     | 12    | 2      | 1       | 1       | 0    | 6.8  |
| 10                  | 26  | 19    | 19    | 5     | 6     | 4     | 1      | 0       | 0       | 0    | 8.0  |
| 11                  | 6   | 3     | 7     | 3     | 1     | 2     | 2      | 0       | 0       | 0    | 2.4  |
| 12                  | 3   | 3     | 8     | 4     | 1     | 2     | 2      | 0       | 0       | 0    | 2.3  |
| 13                  | 5   | 4     | 3     | 0     | 0     | 0     | 0      | 0       | 0       | 0    | 1.2  |
| 14                  | 7   | 2     | 4     | 1     | 1     | 4     | 0      | 0       | 0       | 0    | 1.9  |
| 15                  | 15  | 8     | 13    | 14    | 10    | 2     | 0      | 0       | 0       | 0    | 6.2  |
| 16                  | 10  | 9     | 5     | 6     | 7     | 2     | 2      | 0       | 2       | 0    | 4.3  |
| 17                  | 4   | 6     | 14    | 8     | 8     | 7     | 6      | 0       | 0       | 0    | 5.3  |
| 20                  | 0   | 4     | 10    | 7     | 10    | 5     | 5      | 2       | 0       | 1    | 4.4  |
| 21                  | 3   | 10    | 7     | 13    | 8     | 1     | 1      | 0       | 2       | 0    | 4.5  |
| 22                  | 10  | 8     | 3     | 2     | 4     | 5     | 1      | 2       | 0       | 0    | 3.5  |
| 23                  | 6   | 5     | 7     | 9     | 3     | 0     | 0      | 0       | 0       | 0    | 3.0  |
| 24                  | 8   | 12    | 7     | 3     | 3     | 2     | 0      | 0       | 0       | 0    | 3.5  |
| 25                  | 17  | 18    | 17    | 5     | 8     | 2     | 0      | 0       | 0       | 0    | 6.7  |
| 29                  | 3   | 3     | 8     | 4     | 1     | 2     | 2      | 0       | 0       | 0    | 2.3  |
| 30                  | 11  | 6     | 6     | 2     | 4     | 1     | 0      | 1       | 0       | 0    | 3.1  |
| 31                  | 15  | 20    | 12    | 4     | 1     | 2     | 0      | 0       | 0       | 0    | 5.4  |



TABLE IV.5. Felling damage: LRA test of relationship between natural logarithm of gap areas and dbh of felled trees

| Experimental compartment | Felled trees (n) | Correlation coefficient (r) | Dbh (X) | Gap area (lnY) | Regression coefficient (b) | Variation coefficient (s) |
|--------------------------|------------------|-----------------------------|---------|----------------|----------------------------|---------------------------|
| 1,1                      | 103              | 0.502                       | 63.2    | 5.16           | 0.015                      | 0.585                     |
| 1,2                      | 121              | 0.379                       | 61.6    | 5.44           | 0.013                      | 0.610                     |
| Combined                 | 224              | 0.423                       | 62.4    | 5.31           | 0.014                      | 0.615                     |
| 2,1                      | 65               | 0.583                       | 58.8    | 4.53           | 0.018                      | 0.502                     |
| 2,2                      | 57               | 0.615                       | 59.2    | 4.77           | 0.017                      | 0.357                     |
| Combined                 | 122              | 0.582                       | 59.0    | 4.64           | 0.018                      | 0.451                     |
| 3,1                      | 73               | 0.336                       | 53.1    | 4.44           | 0.013                      | 0.532                     |
| 3,2                      | 74               | 0.404                       | 52.7    | 4.72           | 0.018                      | 0.518                     |
| Combined                 | 147              | 0.353                       | 52.9    | 4.58           | 0.015                      | 0.542                     |
| 4,1                      | 93               | 0.619                       | 63.4    | 4.58           | 0.024                      | 0.606                     |
| 4,2                      | 34               | 0.387                       | 59.9    | 4.83           | 0.020                      | 0.686                     |
| Combined                 | 127              | 0.548                       | 62.4    | 4.64           | 0.023                      | 0.641                     |
| All treatments combined  | 620              | 0.463                       | 59.5    | 4.87           | 0.180                      | 0.647                     |

TABLE IV.6. Felling damage: ANOVA test of the relationship between gap areas and dbh of felled trees

Input table: b-values (regression coefficients)

| Treatment (i) | Replication (j) |       | Sum $b_{ij}$ |
|---------------|-----------------|-------|--------------|
|               | (1)             | (2)   |              |
| 1             | 0.015           | 0.013 | 0.028        |
| 2             | 0.018           | 0.017 | 0.035        |
| 3             | 0.013           | 0.018 | 0.031        |
| 4             | 0.024           | 0.020 | 0.044        |

Output table

| Source of variation | Sum of squares | Degrees of freedom | Mean square | F-value        |
|---------------------|----------------|--------------------|-------------|----------------|
| treatments          | 72.5           | df = 3             | 24.17       |                |
| error               | 23.0           | df = 4             | 5.75        |                |
| total               | 95.5           | df = 7             |             | F(3,4) = 4.20* |

\* Rejected at a significance level of  $\alpha=0.05$

TABLE IV.7. Felling damage: ANOVA test of gap areas

Input table: ln of Y-medians (gap areas)

| Treatment<br>(i) | Replication (j) |        | Sum lnY <sub>ij</sub> |
|------------------|-----------------|--------|-----------------------|
|                  | 1               | 2      |                       |
| 1                | ln 150          | ln 258 | 10.564                |
| 2                | ln 80           | ln 128 | 9.234                 |
| 3                | ln 92           | ln 159 | 9.591                 |
| 4                | ln 105          | ln 120 | 9.441                 |

Output table

| Source of variation | Sum of squares | Degrees of freedom | Mean square | F-value        |
|---------------------|----------------|--------------------|-------------|----------------|
| treatments          | 0.5212         | df = 3             | 0.1737      |                |
| error               | 0.4156         | df = 4             | 0.1039      |                |
| total               | 0.9368         | df = 7             |             | F(3,4) = 1.67* |

\* Rejected at a significance level of  $\alpha=0.05$

# APPENDIX V

## Results of soil tests

TABLE V.1. Soil damage: soil texture in relation to soil depth in skid trails

| Trail (no) | Treatment code | Soil depth (cm) | Particle size ( $\mu\text{m}$ ) distribution (%) |                     |                   |                       |           |         |
|------------|----------------|-----------------|--|---------------------|-------------------|-----------------------|-----------|---------|
|            |                |                 | 500-1000 coarse sand                             | 250-500 medium sand | 100-250 fine sand | 50-100 very fine sand | 2-50 silt | <2 clay |
| 1          | U              | 10-15           | 12.4   | 30.9                | 12.6              | 4.8                   | 6.4       | 33.0    |
|            |                | 35-40           | 10.5   | 23.4                | 11.8              | 5.9                   | 6.3       | 42.1    |
|            |                | 60-65           | 8.3  | 18.0                | 8.3               | 4.8                   | 5.0       | 55.4    |
|            | T1             | 10-15           | 14.6   | 25.7                | 10.2              | 5.3                   | 6.8       | 37.4    |
|            |                | 20-25           | 13.2   | 19.8                | 9.3               | 3.7                   | 5.8       | 48.2    |
|            |                | 40-45           | 13.3   | 16.4                | 6.9               | 3.0                   | 5.0       | 55.5    |
|            | T2             | 5-10            | 19.6   | 26.0                | 10.8              | 4.4                   | 5.8       | 33.4    |
|            |                | 30-35           | 10.6   | 20.6                | 10.4              | 4.0                   | 5.0       | 49.4    |
|            |                | 60-65           | 17.6   | 20.6                | 10.0              | 4.6                   | 4.8       | 42.2    |
|            | T3             | 10-15           | 13.2   | 24.1                | 10.4              | 4.3                   | 5.6       | 42.4    |
|            |                | 35-40           | 10.6   | 22.9                | 12.5              | 5.6                   | 6.6       | 41.8    |
|            |                | 60-65           | 10.3   | 16.7                | 7.3               | 3.7                   | 4.5       | 57.7    |
| 2          | U              | 10-15           | 4.0  | 28.7                | 33.9              | 12.1                  | 8.4       | 13.6    |
|            |                | 25-30           | 12.1   | 31.6                | 9.6               | 4.2                   | 5.8       | 36.7    |
|            |                | 55-60           | 5.1  | 18.9                | 14.8              | 8.6                   | 6.3       | 46.3    |
|            | T1             | 15-20           | 12.9   | 32.7                | 8.5               | 4.0                   | 4.3       | 37.4    |
|            |                | 50-55           | 12.5   | 40.1                | 9.7               | 5.0                   | 4.6       | 28.1    |
|            | T2             | 20-25           | 11.4   | 33.4                | 9.1               | 4.9                   | 5.4       | 35.8    |
|            |                | 50-55           | 10.6   | 34.0                | 8.3               | 4.0                   | 3.8       | 39.3    |
|            | T3             | 20-25           | 12.4   | 31.8                | 7.9               | 4.8                   | 4.7       | 38.4    |
|            |                | 50-55           | 12.1   | 29.5                | 7.9               | 3.3                   | 4.5       | 42.6    |

TABLE V.1. continued

| Trail (no) | Treatment code | Soil depth (cm) | Particle size ( $\mu\text{m}$ ) distribution (%) |                     |                   |                       |           |         |      |
|------------|----------------|-----------------|--|---------------------|-------------------|-----------------------|-----------|---------|------|
|            |                |                 | 500-1000 coarse sand                             | 250-500 medium sand | 100-250 fine sand | 50-100 very fine sand | 2-50 silt | <2 clay |      |
| 3          | U              | 10-15           | 1.9  | 25.2                | 28.7              | 14.0                  | 9.1       | 21.2    |      |
|            |                | 55-60           | 1.6  | 24.4                | 25.7              | 13.2                  | 7.9       | 27.2    |      |
|            | T1             | 20-25           | 3.0  | 26.7                | 28.8              | 11.3                  | 8.2       | 21.8    |      |
|            |                | 55-60           | 0.6  | 12.9                | 18.1              | 9.5                   | 9.5       | 49.6    |      |
|            | T2             | 10-15           | 2.6  | 26.4                | 33.9              | 12.6                  | 6.9       | 17.6    |      |
|            |                | 35-40           | 2.2  | 27.5                | 32.1              | 12.1                  | 6.8       | 19.2    |      |
|            |                | 55-60           | 2.4  | 26.9                | 29.2              | 12.8                  | 6.4       | 22.4    |      |
|            | T3             | 15-20           | 2.0  | 27.0                | 31.7              | 11.7                  | 7.5       | 20.2    |      |
|            |                | 55-60           | 1.8  | 26.0                | 28.1              | 15.4                  | 6.2       | 22.3    |      |
|            | 4              | U               | 10-15  | 2.0                 | 25.6              | 30.8                  | 10.5      | 8.5     | 22.6 |
|            |                |                 | 35-40  | 0.8                 | 14.2              | 22.3                  | 10.6      | 11.0    | 41.1 |
|            |                |                 | 60-65  | 1.2                 | 18.0              | 24.4                  | 10.5      | 8.8     | 36.4 |
| T1         |                | 2- 7            | 1.7  | 23.2                | 34.2              | 14.3                  | 7.5       | 18.9    |      |
|            |                | 20-25           | 0.7  | 11.4                | 16.4              | 10.0                  | 8.8       | 52.9    |      |
|            |                | 45-50           | 1.4  | 18.8                | 26.3              | 11.5                  | 9.8       | 32.2    |      |
|            |                | 60-65           | 4.1  | 17.4                | 11.8              | 6.0                   | 8.1       | 52.7    |      |
| T2         |                | 20-25           | 0.5  | 9.9                 | 15.4              | 8.7                   | 10.9      | 54.6    |      |
|            |                | 50-55           | 1.0  | 18.2                | 28.0              | 10.4                  | 10.8      | 31.6    |      |
|            |                | 65-70           | 13.1   | 33.1                | 8.8               | 2.8                   | 4.1       | 38.0    |      |
| T3         |                | 15-20           | 0.9  | 12.3                | 18.4              | 8.1                   | 9.2       | 51.1    |      |
|            |                | 40-45           | 1.4  | 19.1                | 28.5              | 10.4                  | 9.4       | 31.3    |      |
|            |                | 60-65           | 5.6  | 35.4                | 33.7              | 9.0                   | 6.3       | 9.8     |      |
| 5          |                | U               | 10-15  | 3.8                 | 27.8              | 39.1                  | 15.5      | 5.1     | 8.8  |
|            |                |                 | 40-45  | 4.3                 | 25.0              | 35.2                  | 17.9      | 5.2     | 12.4 |
|            |                |                 | 60-65  | 3.5                 | 25.0              | 34.1                  | 16.9      | 6.8     | 13.6 |
|            |                | T1              | 5-10   | 2.8                 | 27.3              | 38.3                  | 17.2      | 4.9     | 9.3  |
|            |                |                 | 25-30  | 2.2                 | 26.3              | 36.8                  | 16.2      | 6.2     | 12.3 |
|            | 50-55          |                 | 3.4  | 29.9                | 35.2              | 11.7                  | 7.1       | 12.3    |      |
|            | 6              | U               | 2- 7   | 3.0                 | 31.3              | 36.5                  | 13.9      | 3.0     | 12.1 |
|            |                |                 | 30-35  | 2.3                 | 30.8              | 34.3                  | 11.9      | 5.7     | 14.9 |
|            |                |                 | 60-65  | 2.2                 | 31.0              | 31.5                  | 10.6      | 7.4     | 17.1 |

TABLE V.1. continued

| Trail<br>(no) | Treat-<br>ment<br>code | Soil<br>depth<br>(cm) | Particle size ( $\mu\text{m}$ ) distribution (%) |                           |                         |                             |              |            |
|---------------|------------------------|-----------------------|--|---------------------------|-------------------------|-----------------------------|--------------|------------|
|               |                        |                       | 500-1000<br>coarse<br>sand                       | 250-500<br>medium<br>sand | 100-250<br>fine<br>sand | 50-100<br>very fine<br>sand | 2-50<br>silt | <2<br>clay |
|               | T1                     | 10-15                 | 3.3  | 32.4                      | 35.0                    | 12.7                        | 5.1          | 11.5       |
|               |                        | 40-45                 | 2.8  | 33.1                      | 32.6                    | 11.6                        | 5.6          | 14.1       |
|               |                        | 60-65                 | 2.5  | 34.9                      | 31.9                    | 11.1                        | 6.0          | 13.6       |
| 7             | U                      | 10-15                 | 6.2  | 25.3                      | 19.4                    | 7.9                         | 7.9          | 33.3       |
|               |                        | 30-35                 | 6.1  | 22.5                      | 18.2                    | 8.7                         | 5.5          | 39.0       |
|               |                        | 50-55                 | 12.6   | 25.5                      | 7.9                     | 3.2                         | 3.7          | 47.2       |
|               | T1                     | 10-15                 | 7.0  | 24.3                      | 17.7                    | 7.8                         | 6.5          | 33.7       |
|               |                        | 30-35                 | 4.7  | 21.4                      | 16.9                    | 8.4                         | 5.4          | 43.3       |
|               |                        | 50-55                 | 4.4  | 17.4                      | 12.2                    | 5.9                         | 5.3          | 54.8       |
|               | T2                     | 10-15                 | 6.2  | 25.6                      | 19.2                    | 7.8                         | 6.5          | 34.7       |
|               |                        | 30-35                 | 5.5  | 21.9                      | 17.1                    | 7.8                         | 5.6          | 42.1       |
|               |                        | 50-55                 | 4.3  | 25.6                      | 31.3                    | 13.5                        | 9.0          | 16.2       |
| 8             | U                      | 2- 7                  | 6.5  | 29.9                      | 22.0                    | 10.0                        | 6.2          | 25.5       |
|               |                        | 20-25                 | 3.8  | 23.4                      | 20.0                    | 10.6                        | 5.9          | 36.3       |
|               |                        | 50-55                 | 4.4  | 17.5                      | 12.7                    | 6.6                         | 6.3          | 52.4       |
|               | T1                     | 10-15                 | 5.7  | 23.9                      | 18.6                    | 10.0                        | 6.2          | 35.8       |
|               |                        | 50-55                 | 4.8  | 17.8                      | 12.4                    | 5.5                         | 5.8          | 53.7       |

TABLE V.2. Soil damage: bulk density, texture and organic matter content of skid trails

| Soil depth (cm) | Bulk density (g/cm <sup>3</sup> ) |      |      |      | Horizon depth (cm) | Textural composition undisturbed soil (%) |      |      | Organic matter (%) |
|-----------------|-----------------------------------|------|------|------|--------------------|---|------|------|--------------------|
|                 | U                                 | R1   | R2   | R3   |                    | sand                                      | silt | clay |                    |
| <i>Trail 1</i>  |                                   |      |      |      |                    |   |      |      |                    |
| 0-7             | 1.15                              | 1.40 | 1.57 | 1.42 | 0-25               | 60.7                                      | 6.4  | 33.0 | 1.90               |
| 10-15           | 1.33                              | 1.39 | 1.41 | 1.54 |                    |   |      |      |                    |
| 20-25           | 1.30                              | 1.57 | 1.42 | 1.56 | 25-50              | 51.6                                      | 6.3  | 42.1 | 0.85               |
| 30-35           | 1.27                              | 1.43 | 1.41 | 1.40 |                    |   |      |      |                    |
| 40-45           | 1.33                              | 1.34 | 1.41 | 1.44 |                    |   |      |      |                    |
| 50-55           | 1.31                              | 1.34 | 1.44 | 1.39 | 50-70              | 39.4                                      | 5.0  | 55.4 | 0.00               |
| 60-65           | 1.34                              | 1.36 | 1.42 | 1.37 |                    |   |      |      |                    |
| <i>Trail 2</i>  |                                   |      |      |      |                    |   |      |      |                    |
| 0-7             | 1.27                              | 1.26 | 1.33 | 1.30 | 0-20               | 78.7                                      | 8.4  | 13.6 | 1.48               |
| 10-15           | 1.29                              | 1.34 | 1.42 | 1.27 |                    |   |      |      |                    |
| 20-25           | 1.28                              | 1.38 | 1.33 | 1.43 | 20-35              | 57.5                                      | 5.8  | 36.7 | 0.75               |
| 30-35           | 1.33                              | 1.48 | 1.29 | 1.45 |                    |   |      |      |                    |
| 40-45           | 1.32                              | 1.54 | 1.35 | 1.42 | 35-70              | 47.4                                      | 6.3  | 46.3 | 0.41               |
| 50-55           | 1.38                              | 1.51 | 1.40 | 1.42 |                    |   |      |      |                    |
| 60-65           | 1.40                              | 1.46 | 1.37 | 1.43 |                    |   |      |      |                    |
| <i>Trail 3</i>  |                                   |      |      |      |                    |   |      |      |                    |
| 0-7             | 1.09                              | 1.60 | 1.39 | 1.48 | 0-25               | 69.8                                      | 9.1  | 21.2 | 2.01               |
| 10-15           | 1.41                              | 1.54 | 1.46 | 1.52 |                    |   |      |      |                    |
| 20-25           | 1.39                              | 1.51 | 1.45 | 1.51 |                    |   |      |      |                    |
| 30-35           | 1.36                              | 1.52 | 1.45 | 1.48 | 25-70              | 64.9                                      | 7.9  | 27.2 | 1.20               |
| 40-45           | 1.36                              | 1.54 | 1.49 | 1.53 |                    |   |      |      |                    |
| 50-55           | 1.42                              | 1.51 | 1.52 | 1.51 |                    |   |      |      |                    |
| 60-65           | 1.45                              | 1.54 | 1.54 | 1.54 |                    |   |      |      |                    |
| <i>Trail 4</i>  |                                   |      |      |      |                    |   |      |      |                    |
| 0-7             | 1.11                              | 1.37 | 1.37 | 1.44 | 0-20               | 68.9                                      | 8.5  | 22.6 | 1.82               |
| 10-15           | 1.29                              | 1.35 | 1.27 | 1.35 |                    |   |      |      |                    |
| 20-25           | 1.28                              | 1.37 | 1.29 | 1.31 | 20-50              | 47.9                                      | 11.0 | 41.1 | 1.08               |
| 30-35           | 1.28                              | 1.48 | 1.41 | 1.42 |                    |   |      |      |                    |
| 40-45           | 1.31                              | 1.56 | 1.51 | 1.50 |                    |   |      |      |                    |
| 50-55           | 1.42                              | 1.64 | 1.61 | 1.58 | 50-70              | 54.1                                      | 8.8  | 36.4 | 0.48               |
| 60-65           | 1.46                              | 1.71 | 1.65 | 1.44 |                    |   |      |      |                    |
| <i>Trail 5</i>  |                                   |      |      |      |                    |   |      |      |                    |
| 0-7             | 1.20                              | 1.23 | 1.21 | 1.21 | 0-25               | 86.1                                      | 5.1  | 8.8  | 0.95               |
| 10-15           | 1.29                              | 1.36 | 1.30 | 1.32 |                    |   |      |      |                    |
| 20-25           | 1.32                              | 1.36 | 1.33 | 1.31 | 25-60              | 82.4                                      | 5.2  | 12.4 | 0.60               |
| 30-35           | 1.33                              | 1.39 | 1.42 | 1.40 |                    |   |      |      |                    |
| 40-45           | 1.36                              | 1.42 | 1.40 | 1.38 |                    |   |      |      |                    |
| 50-55           | 1.39                              | 1.54 | 1.45 | 1.42 |                    |   |      |      |                    |
| 60-65           | 1.53                              | 1.62 | 1.50 | 1.51 | 60-70              | 79.6                                      | 6.8  | 13.6 | 0.00               |

TABLE V.2. continued

| Soil depth (cm) | Bulk density (g/cm <sup>3</sup> ) |      |      |      | Horizon depth (cm) | Textural composition undisturbed soil (%) |      |      | Organic matter (%) |
|-----------------|-----------------------------------|------|------|------|--------------------|---|------|------|--------------------|
|                 | U                                 | R1   | R2   | R3   |                    | sand                                      | silt | clay |                    |
|                 | <i>Trail 6</i>                    |      |      |      |                    |   |      |      |                    |
| 0-7             | 1.22                              | 1.22 | 1.23 | 1.21 | 0-10               | 84.9                                      | 3.0  | 12.1 | 1.10               |
| 10-15           | 1.33                              | 1.47 | 1.30 | 1.35 | 10-50              | 79.4                                      | 5.7  | 14.9 | 0.81               |
| 20-25           | 1.27                              | 1.40 | 1.33 | 1.40 |                    |   |      |      |                    |
| 30-35           | 1.24                              | 1.36 | 1.35 | 1.33 |                    |   |      |      |                    |
| 40-45           | 1.26                              | 1.43 | 1.40 | 1.38 |                    |   |      |      |                    |
| 50-55           | 1.39                              | 1.49 | 1.42 | 1.41 | 50-70              | 75.5                                      | 7.4  | 17.1 | 0.00               |
| 60-65           | 1.45                              | 1.54 | 1.51 | 1.40 |                    |   |      |      |                    |



TABLE V-3. Soil damage: physical soil factors in relation to soil depth

| Trail<br>(no) | Treatment<br>code | Horizon | Soil<br>depth<br>(cm) | K factor<br>(mm/day) | Field<br>moisture<br>(%) | Moisture content<br>(%) at pF |      | Soil<br>water<br>(mm) | Air volume<br>(%) at pF |      |      |
|---------------|-------------------|---------|-----------------------|----------------------|--------------------------|-------------------------------|------|-----------------------|-------------------------|------|------|
|               |                   |         |                       |                      |                          | 1.2                           | 2.0  |                       | 4.2                     | 1.2  | 2.0  |
| 1             | U                 | A       | 0-25                  | 4990                 | 24.1                     | 28.4                          | 25.1 | 15.4                  | 14.1                    | 4.1  | 8.9  |
|               |                   | B       | 25-50                 | 1160                 | 22.4                     | 27.1                          | 23.7 | 15.5                  | 11.6                    | 8.6  | 13.4 |
|               |                   | C       | 50-70                 | 450                  | 24.4                     | 28.2                          | 25.7 | 19.5                  | 8.9                     | 5.7  | 9.3  |
|               | T1                | A       | 0-15                  | 110                  | 29.7                     | 30.9                          | 29.3 | 19.7                  | 13.1                    | 6.7  | 8.8  |
|               |                   | B       | 15-25                 | 10                   | 23.0                     | 24.2                          | 23.7 | 17.4                  | 9.9                     | 2.8  | 3.5  |
|               |                   | C       | 25-70                 | 20                   | 24.9                     | 27.6                          | 23.9 | 16.1                  | 11.0                    | 7.9  | 13.1 |
|               | T2                | A       | 0-12                  | 280                  | 24.7                     | 29.2                          | 26.1 | 15.5                  | 15.2                    | 4.3  | 8.7  |
|               |                   | B       | 12-50                 | 150                  | 21.6                     | 26.3                          | 22.8 | 15.9                  | 9.7                     | 10.3 | 15.2 |
|               |                   | C       | 50-70                 | 80                   | 25.2                     | 27.9                          | 25.7 | 16.1                  | 13.8                    | 5.5  | 8.7  |
| T3            | A                 | 0-20    | 140                   | 24.5                 | 26.5                     | 24.4                          | 18.0 | 9.3                   | 6.9                     | 9.9  |      |
|               | B                 | 20-50   | 150                   | 22.3                 | 26.5                     | 23.0                          | 13.9 | 12.7                  | 10.1                    | 15.0 |      |
|               | C                 | 50-70   | 40                    | 27.2                 | 30.8                     | 28.8                          | 20.7 | 11.2                  | 5.4                     | 8.2  |      |
| 2             | U                 | A       | 0-20                  | 1810                 | 29.1                     | 34.2                          | 27.4 | 10.3                  | 21.6                    | 9.4  | 17.9 |
|               |                   | B       | 20-35                 | 1760                 | 27.1                     | 28.7                          | 25.6 | 12.3                  | 18.6                    | 7.0  | 11.3 |
|               |                   | C       | 35-70                 | 380                  | 24.9                     | 26.9                          | 24.6 | 15.1                  | 13.6                    | 7.6  | 10.9 |
|               | T1                | A       | 0-30                  | 90                   | 29.6                     | 31.0                          | 29.0 | 15.3                  | 19.0                    | 4.5  | 7.2  |
|               |                   | B       | 30-70                 | 30                   | 21.2                     | 24.0                          | 21.0 | 13.1                  | 11.9                    | 7.4  | 11.9 |
|               | T2                | A       | 0-35                  | 120                  | 25.0                     | 27.1                          | 24.7 | 15.3                  | 14.2                    | 2.1  | 5.7  |
|               |                   | B       | 35-70                 | 70                   | 21.7                     | 27.0                          | 21.8 | 14.2                  | 10.7                    | 8.7  | 16.1 |

TABLE V.3. continued

| Trail (no) | Treatment code | Horizon | Soil depth (cm) | K factor (mm/day) | Field moisture (%) | Moisture content (%) at pF |      | Soil water (mm) | Air volume (%) at pF |      |
|------------|----------------|---------|-----------------|-------------------|--------------------|----------------------------|------|-----------------|----------------------|------|
|            |                |         |                 |                   |                    | 1.2                        | 2.0  |                 | 4.2                  | 1.2  |
| 3          | T3             | A       | 0-30            | 340               | 38.3               | 38.5                       | 35.6 | 26.4            | 8.5                  | 12.0 |
|            |                | B       | 30-70           | 240               | 27.5               | 30.7                       | 26.1 | 15.4            | 9.0                  | 15.1 |
| 3          | U              | A       | 0-25            | 1320              | 26.4               | 31.3                       | 27.0 | 19.4            | 7.5                  | 13.3 |
|            |                | B       | 25-70           | 420               | 23.4               | 26.8                       | 22.0 | 12.2            | 7.7                  | 14.6 |
| 3          | T1             | A       | 0-40            | 290               | 19.5               | 22.9                       | 16.5 | 10.9            | 7.2                  | 17.0 |
|            |                | B       | 40-70           | 240               | 22.3               | 23.8                       | 18.9 | 14.5            | 5.2                  | 12.8 |
| 3          | T2             | A       | 0-25            | 210               | 20.5               | 24.5                       | 21.0 | 16.4            | 6.4                  | 10.7 |
|            |                | B       | 25-45           | 280               | 19.6               | 23.9                       | 21.0 | 15.8            | 8.2                  | 12.5 |
|            |                | C       | 45-70           | 320               | 18.5               | 21.8                       | 17.9 | 13.5            | 5.3                  | 11.5 |
| 3          | T3             | A       | 0-30            | 120               | 19.8               | 23.1                       | 19.4 | 14.0            | 7.5                  | 13.2 |
|            |                | B       | 30-70           | 230               | 20.4               | 22.0                       | 18.3 | 13.8            | 5.6                  | 11.5 |
| 4          | U1             | A       | 0-20            | 320               | 28.4               | 34.5                       | 30.8 | 14.3            | 6.1                  | 10.9 |
|            |                | B       | 20-50           | 190               | 31.1               | 33.9                       | 31.5 | 10.4            | 6.2                  | 9.3  |
|            |                | C       | 50-70           | 20                | 29.0               | 29.6                       | 28.1 | 13.4            | 1.0                  | 3.2  |
| 4          | T1             | A       | 0-15            | 2380              | 30.4               | 31.1                       | 28.6 | 24.5            | 3.6                  | 7.1  |
|            |                | B       | 15-35           | 280               | 35.1               | 36.3                       | 35.0 | 12.5            | 1.5                  | 3.3  |
|            |                | C       | 35-60           | 60                | 26.2               | 26.3                       | 26.1 | 15.0            | 0.1                  | 0.4  |
|            |                | D       | 60-70           | 60                | 20.1               | 19.2                       | 18.2 | 20.1            | 3.2                  | 4.9  |

TABLE V.3. continued

| Trail<br>(no) | Treatment<br>code | Horizon | Soil<br>depth<br>(cm) | K factor<br>(mm/day) | Field<br>moisture<br>(%) | Moisture content<br>(%) at pF |      | Soil<br>water<br>(mm) | Air volume<br>(%) at pF |      |
|---------------|-------------------|---------|-----------------------|----------------------|--------------------------|-------------------------------|------|-----------------------|-------------------------|------|
|               |                   |         |                       |                      |                          | 1.2                           | 2.0  |                       | 4.2                     | 1.2  |
| T2            | A                 | 0-40    | 170                   | 34.9                 | 36.6                     | 34.4                          | 25.6 | 11.4                  | 3.4                     | 6.2  |
|               | B                 | 40-65   | 40                    | 27.9                 | 28.5                     | 26.8                          | 16.2 | 15.8                  | 1.3                     | 3.8  |
|               | C                 | 65-70   | 150                   | 22.8                 | 22.9                     | 18.3                          | 7.6  | 17.1                  | 3.0                     | 10.3 |
| T3            | A                 | 0-30    | 10                    | 32.9                 | 34.4                     | 33.4                          | 21.8 | 15.9                  | 1.2                     | 2.5  |
|               | B                 | 30-55   | -                     | 23.0                 | 26.3                     | 22.8                          | 13.6 | 13.7                  | 4.6                     | 9.8  |
|               | C                 | 55-75   | 30                    | 20.2                 | 19.8                     | 16.8                          | 3.7  | 21.4                  | 6.2                     | 11.1 |
| 5             | U                 | 0-25    | 1910                  | 20.7                 | 34.8                     | 23.4                          | 5.7  | 22.5                  | 7.9                     | 22.4 |
|               | B                 | 25-60   | 640                   | 19.4                 | 26.6                     | 19.0                          | 7.9  | 15.3                  | 11.2                    | 21.7 |
|               | C                 | 60-70   | 620                   | 20.0                 | 23.4                     | 17.6                          | 7.8  | 15.0                  | 6.5                     | 15.3 |
| T1            | A                 | 0-15    | 630                   | 24.7                 | 31.3                     | 26.0                          | 6.4  | 26.3                  | 7.5                     | 14.6 |
|               | B                 | 15-40   | 560                   | 24.0                 | 29.9                     | 23.7                          | 9.2  | 19.1                  | 10.7                    | 18.9 |
|               | C                 | 40-70   | 90                    | 17.8                 | 19.9                     | 16.5                          | 8.3  | 13.4                  | 6.1                     | 11.6 |
| 6             | U                 | 0-10    | 2850                  | 27.8                 | 36.0                     | 27.8                          | 7.4  | 25.5                  | 7.8                     | 18.1 |
|               | B                 | 10-50   | 610                   | 20.5                 | 32.8                     | 20.6                          | 7.9  | 16.1                  | 10.4                    | 25.9 |
|               | C                 | 50-70   | 440                   | 17.2                 | 21.3                     | 15.8                          | 7.7  | 12.4                  | 9.7                     | 18.1 |
| T1            | A                 | 0-20    | 180                   | 22.8                 | 26.4                     | 22.9                          | 7.5  | 22.2                  | 7.6                     | 12.7 |
|               | B                 | 20-60   | 890                   | 18.5                 | 23.0                     | 16.6                          | 6.9  | 14.5                  | 9.5                     | 19.0 |
|               | C                 | 60-70   | 710                   | 17.0                 | 22.1                     | 13.6                          | 6.3  | 11.2                  | 8.4                     | 21.5 |

TABLE V.3. continued

| Trail<br>(no) | Treatment<br>code | Horizon | Soil<br>depth<br>(cm) | K factor<br>(mm./day) | Field<br>moisture<br>(%) | Moisture content<br>(%) at pF |      | Soil<br>water<br>(mm) | Air volume<br>(%) at pF |      |
|---------------|-------------------|---------|-----------------------|-----------------------|--------------------------|-------------------------------|------|-----------------------|-------------------------|------|
|               |                   |         |                       |                       |                          | 1.2                           | 2.0  |                       | 4.2                     | 1.2  |
| 7             | U                 | A       | 0-20                  | 1750                  | 25.1                     | 32.2                          | 26.4 | 17.7                  | 7.0                     | 14.7 |
|               |                   | B       | 20-40                 | 560                   | 22.1                     | 28.7                          | 23.5 | 12.6                  | 9.0                     | 16.1 |
|               |                   | C       | 40-70                 | 610                   | 22.7                     | 30.5                          | 24.7 | 12.6                  | 9.9                     | 17.6 |
| R(T2*)        | A                 | A       | 0-20                  | 240                   | 25.1                     | 30.3                          | 25.5 | 17.4                  | 6.8                     | 13.4 |
|               |                   | B       | 20-40                 | 150                   | 24.8                     | 27.5                          | 25.4 | 15.4                  | 6.1                     | 9.1  |
|               |                   | C       | 40-70                 | 240                   | 26.4                     | 29.4                          | 27.1 | 11.5                  | 8.0                     | 11.2 |
| R(T5*)        | A                 | A       | 0-30                  | 260                   | 25.3                     | 27.5                          | 25.9 | 18.1                  | 5.4                     | 7.7  |
|               |                   | B       | 30-70                 | 100                   | 24.8                     | 27.7                          | 25.8 | 9.4                   | 7.1                     | 9.8  |
| 8             | U                 | A       | 0-20                  | 1220                  | 26.1                     | 28.8                          | 27.2 | 20.3                  | 4.2                     | 6.5  |
|               |                   | B       | 20-40                 | 240                   | 25.6                     | 29.3                          | 25.8 | 15.4                  | 6.8                     | 11.7 |
|               |                   | C       | 40-70                 | 180                   | 26.5                     | 29.1                          | 27.3 | 12.4                  | 5.1                     | 7.6  |
| R(T1*)        | A                 | A       | 0-10                  | 210                   | 27.0                     | 29.3                          | 26.6 | 22.7                  | 6.1                     | 9.9  |
|               |                   | B       | 10-30                 | 290                   | 25.0                     | 27.2                          | 24.9 | 16.4                  | 9.1                     | 12.3 |
|               |                   | C       | 30-70                 | 190                   | 26.5                     | 29.0                          | 27.2 | 12.4                  | 7.2                     | 9.7  |

\* After trip no 1, no 2, no 5

# APPENDIX VI

## Rimpull-speed graph

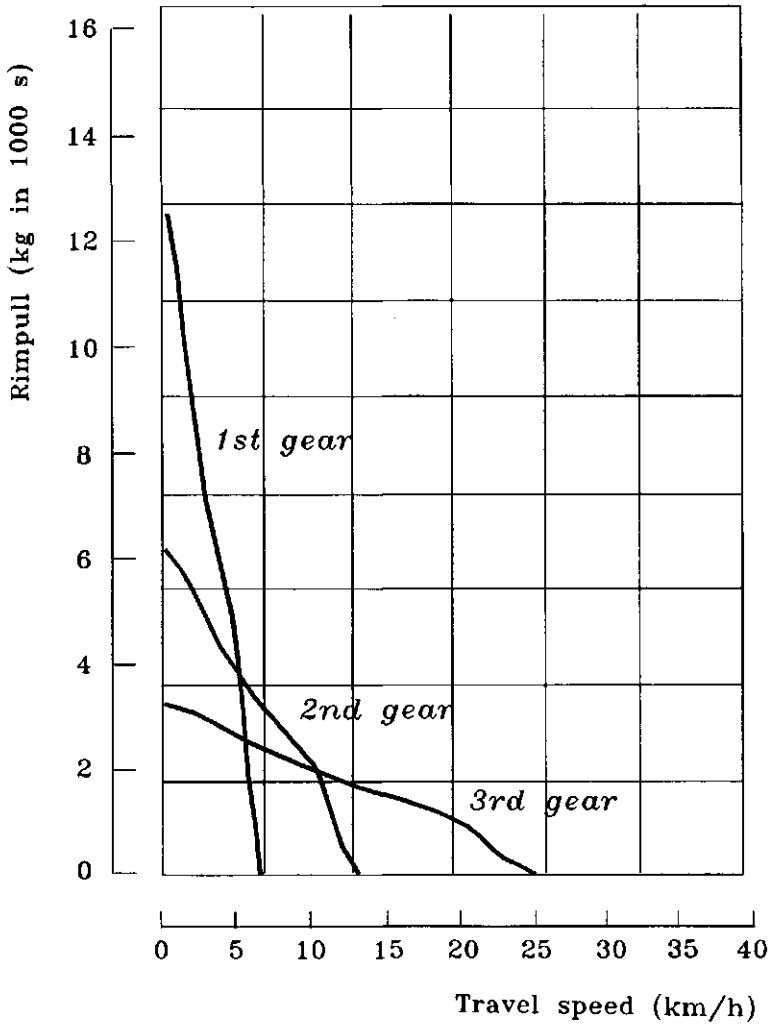


Fig. VI.1 Relationship between rimpull and travel speed of a wheeled skidder. The rimpull of the skidder is calculated by reducing its available tractive force with resistance forces (see Section 6. 3; Source: Caterpillar, 1986)

## APPENDIX VII

### Appraisal of commercial and potential species

Research in the past decades has identified many lesser know timber species as being technically suitable for a wide range of end uses. The CELOS list of commercial species is based on this research. The approximately 60 botanical species in this list are tended in the CELOS Management System to generate the future timber stock.

The optimistic predictions of the 1970s that harvested volumes could easily be tripled have not been fulfilled. At present, 30 timber species are marketed regularly, corresponding to a yield of roughly 10 to 20 m<sup>3</sup> per ha. In well stocked and efficiently logged forests, occasionally volumes of up to 30 m<sup>3</sup>/ha are harvested. The theoretical harvest, however, could be a manifold of this quantity, if all the tested timbers are considered. This is demonstrated by the analysis of inventory data of a pulpwood experiment carried out in the Mapane forest (LBB, 1971).

The experiment involved clear felling of all trees >20 cm dbh. The species identified as commercial and potential timber are listed in Table VII.1, by name, gross stem volume and use class. The total volume was assessed to be 129.38 m<sup>3</sup>/ha or 66% of the total standing stem volume of all species. The volume by use class is as follows:

|               |             |                    |
|---------------|-------------|--------------------|
| - saw logs    | 50.85       | m <sup>3</sup> /ha |
| - veneer logs | 36.36       | m <sup>3</sup> /ha |
| - poles       | 24.17       | m <sup>3</sup> /ha |
| - piles       | 14.81       | m <sup>3</sup> /ha |
| - others      | <u>3.19</u> | m <sup>3</sup> /ha |
| total         | 129.38      | m <sup>3</sup> /ha |

In terms of market demand, the categories saw and veneer logs are of interest. Hewn wooden, electric poles are commonly used in Suriname but only durable species such as bruinhart (*Vouacapoua americana*) and walaba (*Eperua falcata*) are harvested for this purpose. The domestic market is presently too limited for further expansion and there is not yet potential for export of this commodity. Besides, timber like bruinhart has a higher value as sawn wood than as hewn poles. The same is the case with basralokus (*Dicorynia guianensis*) which has a small but

TABLE VII.1. Mapane forest: list of commercial and potential species, volume per ha and use class

| Family                           | Scientific name   | Vernacular name  | Gross volume (m <sup>3</sup> /ha)                         | Use class   |
|----------------------------------|---|--|---|---|
| Anacardiaceae                    | <i>Loxopterygium sagotii</i>  | slangenhout  | 0.46  | furniture wood  |
| Apocynaceae                      | <i>Aspidosperma album</i> ;<br><i>A. megalocarpon</i>   | kromantikopi*  | 0.10  | sawn wood   |
| Araliaceae                       | <i>Schefflera morotonii</i>   | kassavehout  | 0.12  | plywood   |
| Bignoniaceae                     | <i>Tabebuia serratifolia</i><br><i>Jacaranda copaia</i>   | groenhart<br>goebaja   | 1.68<br>1.20  | sawn wood<br>plywood  |
| Burseraceae                      | <i>Protium spp.</i><br><i>Tetragastris altissima</i>  | tingimoni<br>rode sali   | 7.30<br>10.32   | plywood<br>sawn wood  |
| Celastraceae                     | <i>Goupia glabra</i>  | kopi   | 5.94  | sawn wood   |
| Combretaceae                     | <i>Buchenavia capitata</i>  | djiendja oedoe*  | 2.71  | sawn wood   |
| Euphorbiaceae                    | <i>Chaetocarpus schomburgkianus</i>   | fomang*  | 6.64  | poles   |
| Guttiferae                       | <i>Platonia insignis</i> ;<br><i>Rheedia benthamiana</i><br><i>Symphonia globulifera</i>  | pakoeli<br>mataki  | 0.28<br>1.60  | sawn wood<br>sleepers   |
| Lauraceae                        | <i>Licaria, Nectandra,</i><br><i>Ocotea spp</i><br><i>Ocotea rubra</i>  | pisi<br>wana   | 4.08<br>0.40  | sawn wood<br>sawn wood  |
| Lecythidaceae                    | <i>Couratari spp.</i><br><i>Eschweilera odora</i><br><i>Eschweilera corrugata</i><br><i>Lecythis davisii</i>  | ingipipa*<br>manbarklak*<br>oemabarklak*<br>kwatapatoe   | 17.42<br>7.81<br>2.78<br>1.14                             | plywood<br>piles<br>piles<br>sawn wood  |
| Leguminosae-A<br>(Mimosaceae)    | <i>Parkia nitida</i><br><i>Piptadenia suaveolens</i>  | agrobigi<br>pikinmisiki*   | 0.60<br>8.00  | plywood<br>sawn wood  |
| Leguminosae-B<br>(Papilionaceae) | <i>Eperua falcata</i><br><i>Sclerobium albiflorum</i><br><i>Andira spp.</i><br><i>Diploptropis purpurea</i><br><i>Dicorynia guianensis</i><br><br><i>Peltogyne pubescens</i><br><i>Vouacapoua americana</i> | walaba*<br>rode djedoe*<br>rode kabbes<br>zwarte kabbes<br>basralokus<br><br>purperhart<br>bruinhart | 14.32<br>2.42<br>0.85<br>0.28<br>4.22<br><br>0.68<br>1.33 | poles<br>sawn wood<br>furniture<br>wood<br>piles;<br>sawn wood<br>sawn wood<br>poles<br>sawn wood |

TABLE VII.1. continued

| Family        | Scientific name  | Vernacular name | Gross volume (m <sup>3</sup> /ha) | Use class |
|---------------|--|-----------------|-----------------------------------|-----------|
| Meliaceae     | <i>Carapa procera</i>  | krapa           | 4.08                              | sawn wood |
| Myristicaceae | <i>Virola melinonii</i>  | hgl. baboen     | 3.40                              | plywood   |
| Rosaceae      | <i>Couepia versicolor</i>  | anaura*         | 1.36                              | poles     |
|               | <i>Licania micrantha</i> ;<br><i>Parinari campestris</i>           | foengoe*        | 0.52                              | poles     |
|               |  |                 |                                   |           |
| Sapotaceae    | <i>Micropholis guyanensis</i> ;<br><i>Pouteria engleri</i>         | riemhout        | 6.20                              | sawn wood |
| Simaroubaceae | <i>Simarouba amara</i>   | soemaroeba      | 0.20                              | sawn wood |
| Sterculiaceae | <i>Sterculia excelsa</i> ;<br><i>S. pruriens</i>                   | okro oedoe      | 3.68                              | plywood   |
| Vochysiaceae  | <i>Vochysia spp</i>  | kwari           | 2.64                              | plywood   |
|               | <i>Qualea albiflora</i> ;<br><i>Q. coerulea</i><br><i>Q. rosea</i> | gronfoeloe      | 2.62                              | sawn wood |
|               |  |                 |                                   |           |
|               |  |                 |                                   |           |
|               |  |                 | 129.38**                          |           |

Source: LBB, 1971

\* Not on the CELOS list of commercial species

\*\* Total volume

stable export market for marine piles. Basralokus is better sold as sawn wood because of its attractive appearance and good mechanical properties. There is no export market for manbarklak (*Eschweilera odorata*) and oemabarklak (*Eschweilera corrugata*). Wood testing focused on plywood technology to find more timber species to process. The present number of veneer species is probably the maximum achievable. From the eight species harvested for plywood, face veneer of export grade can be produced from three species, while the remainder are only suitable for core veneer. The gross volume of approximately 36 m<sup>3</sup>/ha comprises about 50% ingipipa (*Couratari spp.*), a species which is not abundantly available everywhere. Of the other species, a substantial proportion of mature peeler logs are rejected because of internal defects and irregular stem shape. When these restrictions are taken into account, the volume of usable logs seldom exceeds 10 m<sup>3</sup>/ha.

Most timber species can be used for sawn wood production, but only a few give an economic return. The great variation in physical and mechanical properties is reflected by the different grades of sawn wood. The domestic market is potentially saturated with sawn wood, whereas regular export is limited to four species only.



Consequently, a number of timbers are seldom harvested due to higher conversion costs and lesser wood quality. In this category pikinmisiki (*Piptadenia suaveolens*), rode sali (*Tetragastris altissima*) and riemhout (*Micropholis guyanensis*) are relatively abundant. For these reasons, saw log production is generally dominated by only seven species, presenting an average volume of 10-20 m<sup>3</sup>/ha.