

Monitoring fisheries in data-limited situations

A case study of the artisanal reef fisheries of Eritrea

Promotor

Prof. Dr. Johan A.J. Verreth
Hoogleraar in de Aquacultuur en Visserij
Wageningen Universiteit

Co-promotor

Dr. Ir. Leopold A.J. Nagelkerke
Universitair Docent, leerstoelgroep Aquacultuur en Visserij
Wageningen Universiteit

Promotiecommissie

Prof. Dr. M. Scheffer
Wageningen Universiteit

Prof. Dr. A.D. Rijnsdorp
Rijksuniversiteit Groningen
Imares, Wageningen Universiteit en Research Centrum

Dr. Ir. J.A.E. van Oostenbrugge
LEI, Wageningen Universiteit en Research Centrum

Dr. I. Nagelkerken
Radboud Universiteit Nijmegen

Dit onderzoek is uitgevoerd binnen de onderzoekschool
Wageningen Institute of Animal Sciences (WIAS)

Monitoring fisheries in data-limited situations

A case study of the artisanal reef fisheries of Eritrea

Iyob Tsehaye

Proefschrift

ter verkrijging van de graad van doctor
op gezag van de rector magnificus
van Wageningen Universiteit,
Prof. dr. M.J. Kropff,
in het openbaar te verdedigen
op dinsdag 13 november 2007
des namiddags te half twee in de Aula

Tsehaye, I., 2007

Monitoring fisheries in data-limited situations: A case study of the artisanal reef fisheries of Eritrea

PhD Thesis, Wageningen University, the Netherlands

With summary in English, Dutch and Tigrigna

ISBN: 978-90-8504-773-5

*Dedicated to my parents:
Tsehay Weldemichael and Azieb Ghebrelul*

Abstract

Elucidating trends in catch rate and composition is important to evaluate the impact of fishing on fish stocks, and thereby guide fisheries management action. Since major changes in fish community structure can take place even at the initial stages in the development of fisheries, the onset of reef fisheries in the Eritrean Red Sea provides a good opportunity to assess the effects of fishing on fish community structure in the early stages of fisheries. The artisanal reef fisheries of Eritrea were launched into a renewed development in 1991 after the end of a decades-long standstill, which was caused by the war for Eritrea's independence. The main objective of this thesis was to evaluate the sustainability of existing fishing practices in the newly developing artisanal reef fisheries of Eritrea, while simultaneously exploring more effective ways of monitoring of fisheries and fish stocks.

Analysis of official statistics from the artisanal fisheries showed that annual effort and annual catch increased upon the expansion of the fisheries, while the total catch rate remained unchanged over the years. However, disaggregation of catch rates into different taxonomic and ecological categories showed varying trends in catch rates of the different groups of fishes, resulting in a clear shift in catch composition over the years. These results are not unlikely given the supposedly large amounts of unreported catches, which are mostly taken illegally to Yemen. This is more so given the highly selective nature of species targeting strategies in the artisanal fisheries. These findings are also consistent with other studies suggesting that stocks of reef-associated demersal species are highly vulnerable to fishing and can decline even at the early stages of fisheries. Furthermore, the results from this study show that the impacts of fishing in the artisanal fisheries could even become more severe if market conditions improve leading to the activation of latent fishing capacity. That having been said, even though the changes in catch rate could be interpreted as reflecting changes in the underlying fish community structure, they could also be partly due to shifts in fish targeting strategies driven by socio-economic circumstances.

The relationship between catch rate and effort in the artisanal fisheries could be elucidated more accurately by standardizing catch rates for systematic variations among fishing vessels, which would otherwise cause non-random variations in catch rate unrelated to abundance. The effectiveness of the monitoring program in these fisheries could also be improved through aggregation of catch data. The catch data from the artisanal fisheries could be aggregated into three distinct ecological categories, without considerable loss of

Abstract

information on trends in the catch rate of individual species. These categories included reef-associated demersals, open-water pelagics and near-reef pelagics. Aggregation of catch data into these ecological categories was found to improve the statistical power to detect trends. Moreover, besides improving statistical power, aggregate catch rates could provide better insight into community-level responses to exploitation.

An Ecopath with Ecosim model was used to verify if the fishery-induced changes in yield and abundance of fish implied by official statistics are likely, given the existing levels of fishing intensity. This model was also used to explore optimal harvesting strategies for the artisanal fisheries by examining the ecosystem effects of fishing. A retrospective simulation of trends in catch rate (yield) using Ecosim showed that, given the existing fishing intensity as suggested by official statistics, a decline in yield or abundance of reef-associated demersals of the magnitude suggested by trends in catch rate are unlikely. The decline in yield observed in these fisheries could however be reproduced in an Ecosim simulation when the existing fishing level was assumed to be fivefold the official estimate, as suggested by anecdotal evidence on unreported catches. The simulation results also suggest that an optimal fishing strategy could be achieved in the artisanal fisheries through a slight reduction in the annual catch of reef-associated fishes and an increase in the capture of near-reef pelagics and large pelagics from the putative levels of fishing.

Contents

Chapter 1	General introduction	1
Chapter 2	Rapid shifts in catch composition in the artisanal Red Sea reef fisheries of Eritrea	19
Chapter 3	Changes in catch composition in the multispecies fisheries of Eritrea in relation to biological and socio-economic factors	49
Chapter 4	Improving the effectiveness of monitoring programs in multispecies fisheries through aggregation of catch data into ecological categories	77
Chapter 5	Exploring optimal fishing scenarios for the multispecies artisanal fisheries of Eritrea using a trophic model	105
Chapter 6	General discussion	141
	Summary in English, Dutch and Tigrigna	163
	Acknowledgements	177
	Training and supervision plan	179
	Curriculum vitae	180
	List of publications	181

CHAPTER 1

General introduction

1. Importance and management of reef fisheries

Reef fisheries are important socially, nutritionally and economically, providing a direct source of income and food for hundreds of thousands of coastal communities (Sadovy, 2005). These fisheries are particularly important in developing countries, where coral reef ecosystems support an estimated annual yield of approximately 6 million tonnes per year (Munro, 1996; Allison and Ellis, 2001). Reef fisheries are inherently of multispecies nature, with any given type of gear capturing a wide range of species. The harvest from an intensively exploited coral reef ecosystem typically includes hundreds of species of fishes, although fewer than 20 species make up the bulk of harvests in most fisheries (Jennings and Polunin, 1996b; Kuster et al., 2005). Whereas some reef fisheries particularly target higher-value species such as groupers (Serranidae), snappers (Lutjanidae) and emperors (Lethrinidae), most reef fisheries of developing countries are non-selective, targeting every species of fish unless they are poisonous (Munro, 1996). As a result, reef fisheries are considered less wasteful, and hence more efficient, supporting more livelihoods with a given harvest than industrial fisheries (Sadovy, 2005).

Compared with other fisheries, coral reef fisheries are nevertheless under-monitored and under-managed (Sadovy, 2005). There are several reasons why management is not so well developed in most reef fisheries. First, coral reef fisheries are mostly considered of low economic value at national and global levels, undermining the need for their monitoring and management (Kronen, 2004). Second, artisanal fishing techniques in most reef fisheries are perceived to be environmentally benign – although there is increasing awareness to the contrary (Sadovy, 2005) – with little impact on coral reef ecosystems (Hawkins and Roberts, 2003). In addition, fishing pressure is usually considered too low to have considerable effect on fish stocks. In addition, most reef fisheries are located in developing countries, where there are limited resources for their management. As a result, little focus has been given to the management of reef fisheries thus far, with interest being more on their development (Hawkins and Roberts, 2003). However, contrary to the general perception that marine ecosystems are hardly threatened by artisanal fishing, coral reef fisheries have widely come under pressure in the last few decades due mainly to artisanal fisheries (Hawkins and Roberts, 2003). Growing coastal populations, economic developments, improvements in fishing technology, rising living standards and globalization of trade have also exacerbated the pressure on many coral reef ecosystems (Dalzell, 1998; Russ, 2002). Accordingly, impacts of fishing have been documented for a

variety of tropical reef fisheries (e.g. Ruttenberg, 2001; Hawkins and Roberts, 2003). In the last 10–20 years, increasing fishing pressure resulted in marked declines in several fish stocks, ranging from groupers in the tropical western Atlantic, to the bumphead parrotfish and humphead wrasse in the Solomon Islands (Aswani and Hamilton, 2004; Sadovy, 2005).

This thesis aims to evaluate the sustainability of existing fishing practices in the newly developing artisanal reef fisheries of Eritrea, while simultaneously examining the possibilities for extracting useful information on the state of fisheries and fish stocks from landing data in these otherwise data-limited fisheries. Furthermore, it explores approaches to improving the effectiveness of existing monitoring programs in order to gain a better insight into the state of fish stocks and fisheries. The next section of this introductory chapter presents a review of present knowledge of fishing impacts on populations of target and non-target species and their reef habitat. This section also discusses the capabilities and limitations in the assessment of fishing impacts and their implications for fisheries management. The third section presents the background and present state of coral reef fisheries in Eritrea, followed by an outline of the objectives of the subsequent chapters.

2. Monitoring fishing impacts in reef fisheries

2.1. Direct and indirect effects of fishing on coral reef communities

Although reef fish communities as a whole are highly vulnerable to exploitation, the most obvious of fishing impacts involve target species, which mainly include the commercially most important piscivorous fishes, such as snappers (Lutjanidae), groupers (Serranidae) and emperors (Lethrinidae) (Jennings and Polunin, 1996; McClanahan et al, 1999; Ruttenberg, 2001; Hawkins and Roberts, 2004). Compared with fish species that support industrial-scale fisheries, most of the target species in reef fisheries are characteristically vulnerable to over-exploitation because of their biology, especially their longevity, natural rarity and associated life-history traits, such as late sexual maturity (Jennings et al., 1999). In addition, whereas the decline in piscivorous species may arise because these species are specifically targeted for their market value, the same could also occur in non-selective fisheries because the larger-sized predatory species are usually vulnerable to a wider range of fishing gears than herbivores or planktivores (Munro, 1996). For example, parrotfishes (Scaridae) can only be caught by traps, nets or spears, while groupers (Serranidae) are vulnerable to almost every sort of artisanal fishing gear and are generally more catchable (Munro, 1996).

The initial responses of fishing become apparent when reserves or previously unfished areas are opened or become accessible to fishing, and they are manifested as a decrease in numerical abundance and biomass of target species (Jennings and Lock, 1996). The progressive loss of target species causes gradual shifts in fish community structure (Koslow et al., 1988). The ultimate result of such changes could be an exploited community composed largely of the least desirable species of fishes – commonly known as “trash fish” – with the higher-value species largely depleted. For example, at heavily exploited sites in Jamaica, fishing had reduced the abundance of groupers, snappers, parrotfishes and triggerfishes, and led to a community dominated by the less desirable boxfishes (Ostraciidae), pufferfishes (Tetraodontidae) and squirellfishes (Holocentridae) (Koslow et al., 1988). The impacts of fishing are also reflected in the size and species composition of fisheries yield. Fishers mostly experience an initial decline in catch per unit of effort (CPUE) of target species, accompanied by changes in species composition, and eventually followed by a decline in total catch at high levels of exploitation (Jennings and Lock, 1996).

In addition to direct effects of fishing, the removal of predatory species is also known to have cascading effects on non-target fish and invertebrate populations and their reef habitat, potentially leading to changes in the structure and function of reef ecosystems (Jennings and Polunin, 1997; Dulvy et al., 2004; Mumby et al., 2006; Campbell and Pardede, 2006). In East Africa, for example, fishing depleted trigger fish populations to such an extent that their herbivorous sea-urchin preys increased in abundance (McClanahan and Shafir, 1990). This in turn resulted in less algae and higher rate of bioerosion, which caused a decline in coral cover (McClanahan, 1996). Similarly, a decrease in predator densities in Fijian islands resulted in elevated densities of the coral-eating crown-of-thorns starfish, *Acanthaster planci*, subsequently leading to the degradation of coral reefs (Dulvy et al., 2004). It has also been documented that herbivorous fishes in heavily fished areas in the Caribbean could not control algae invading corals following the Caribbean-wide mass mortality of the herbivorous sea urchin *Diadema antillarum* in 1983–1984, leading to corals being overgrown by fleshy macroalgae (Hawkins and Roberts, 2004).

Coral reef communities are so vulnerable to fishing that a decline in fish abundance can take place even at low levels of fishing or at the early stages of fisheries (Munro, 1996). For example, in Fijian reef fisheries, significant differences between fish communities in reserves and adjacent areas resulted from relatively low fishing effort and annual catch rates equivalent to 5% of the standing biomass (Jennings and Polunin, 1996a). Fishing was also

suggested as the cause of depletion (33%) of a wide range of fish groups over a period of ten years in Jamaican reef fisheries (Koslow et al., 1994). Similarly, a rapid decline in giant clam (*Tridacna gigas*) populations as a result of fishing was registered for the Pacific region (Villanoy et al., 1988; Wells, 1997). Similar changes were also reported for the Galapagos, where artisanal fishing reduced the proportion of bacalao (*Mycteroperca olfax*), a large grouper, in the catches by about 50% over a period of ten years (Ruttenberg, 2001).

2.2. Assessing fishing impacts in data-limited situations

Fisheries management ought to be based on reliable predictions of the consequences of alternative fishing strategies (Jennings and Polunin, 1996). This requires a sound knowledge on the status of fish stocks at a given time, and how these stocks would respond to different levels of exploitation. However, fishing impacts have often been treated as synonymous with overfishing, with most studies focusing on simple comparisons of heavily and lightly fished or unfished areas, or on examination of catastrophic declines rather than on long-term changes that may occur at the initial stages of fisheries or in sustainable fisheries (Jennings and Polunin, 1996; Kuster et al., 2005). As a result, existing knowledge of impacts of reef fisheries has been limited, constraining our ability to explore optimal fishing strategies (Jennings and Lock, 1996). Thus, given that significant changes in reef fish community structure can take place even at the initial stages in the development of fisheries (Dulvy et al., 2004a,b), the onset of the artisanal reef fisheries in the Eritrean Red Sea provides an opportunity to assess the impacts of fishing on fish community structure in a newly developing fishery.

Information about the status of fisheries can be derived from different sources, such as monitoring the fishery (landing, catch and effort data), biological surveys, information from resource users and from similar resources in other locations (Vasconcellos and Cochrane, 2005). However, readily available information on coral reef fisheries, even for major commercial reef species, is scarce compared with what is available on the large industrial-scale fisheries of temperate regions, limiting our understanding of their functioning and potential response to fishing (Pauly 1994). Often, the data available to assess the status of fisheries in tropical countries are only landings of target species (Vasconcellos and Cochrane, 2005). One of the major factors impeding the assessment of fishing impacts in reef fisheries has thus been the scarcity of fishery-independent data (Sadovy, 2005). This problem is compounded by the multiplicity of species, an effective assessment and management of which obviously requires a wide range of information. Indeed, it might be

unrealistic to expect a thorough collection of fishery-independent data in reef fisheries of limited economic importance, as they are unlikely to be selected for rigorous scientific study (Jennings and Lock, 1996).

Due to the scarcity of data, conventional methods of fish stock assessment, which are often used in temperate fisheries, are not readily applicable in reef fisheries (Magnusson, 1995; Sparre, 1991). The data-limited situation in most reef fisheries makes the use of catch and effort data the most practical option for evaluating the status of fisheries and fish stocks (Sparre and Venema, 1998, Vasconcellos and Cochrane, 2005). In the use of catch and effort data to monitor the state of fish stocks, changes in catch rate are assumed to reflect changes in fish abundance, with changes in species composition indicating changes in community structure. Indeed, the composition of landings could be affected by a number of phenomena that are simply not related to increased fishing pressure – e.g. changes in species preferences, changes in fishing technology, and natural oscillations in abundance etc. – potentially leading to spurious conclusions regarding the state of fish stocks. In view of that, catch rates can only be used as valid indicators of abundance if they are adjusted to account for changes in non-biological factors that can potentially drive changes in the fisheries (King, 1995; Caddy et al., 1998; Myers and Worm, 2003).

In most tropical reef fisheries, it is also hard to collect reliable and comprehensive fishery-dependent statistics, because of the large heterogeneity of fishing activities, comprising of a wide variety of target species, gear types, landing sites, and distribution channels (King and Lambeth, 2000; Lunn and Dearden, 2006). In addition, in many of these fisheries, landings and catch are not necessarily the same because of large amounts of unreported or under-reported catches, discards and illegal catches (Vasconcellos and Cochrane, 2005). As a result, data on catch and effort often lack essential details, such as location of fishing grounds, and catches are mostly identified to higher taxonomic levels. Given the poor quality of official statistics on landings and fishing effort, assessing trends in reef fish production in a way that accurately reflects the state of fish stocks is often difficult (Sadovy, 2005). In this regard, the Food and Agriculture Organization of the United Nations (FAO) acknowledges that the rampant lack of basic data on subsistence and small-scale fisheries contributes to failures in management and policy-making directed at preventing overexploitation and stock decline (FAO, 2002).

Yet, despite the numerous shortcomings in the collection of data from multispecies and multigear reef fisheries, judicious use of catch and effort data may still provide useful

insights into the state of fish stocks and fisheries (Sadovy, 2005). To achieve this, catch data should be adjusted by accounting for variations among observed combinations of gear, effort and catch composition that could confound actual patterns in catch rate, and potentially bias the assessment of trends in fish stocks and fisheries. Ideally, catch and effort statistics should be supplemented by fishery-dependent and independent measures of fishing impacts, such as body size of fish so that it would allow a more direct interpretation of the ecological significance of trends derived from fisheries statistics.

Nowadays, there are increased calls for a transition from single-species toward ecosystem-based management of fisheries (Christensen and Pauly, 2004; Marasco et al., 2007). Ecosystem-based fisheries management is mainly based on food web considerations. This issue has been addressed more extensively in the relatively data-rich developed world. But it remains a challenge in most tropical multispecies fisheries, owing to the pervasive scarcity of ecological data (Bundy and Pauly, 2001). In many of these fisheries, there is still lack of sufficient information for many fishes on the food consumption, electivity and other parameters that govern trophic interactions. Due to the paucity of ecological and fisheries data, the application of sophisticated assessment methods such as multispecies Virtual Population Analysis, would prove difficult in tropical ecosystems (Bundy, 2001). This underlines the need for the development of models with less data requirements. In this regard, successful development of the Ecopath with Ecosim software has provided a tool for examining ecosystem effects of fishing, and thereby optimizing fishing strategies. This method has relatively limited data requirements, and yet provides an ecological perspective for the assessment and management of multispecies, multigear fisheries.

3. The fisheries of Eritrea

3.1. Fisheries resources on coral reefs and adjacent areas

Eritrea is located along the southern coast of the Red Sea, with its coral reef resources forming an important basis for the development of artisanal fisheries (Fig. 1). Eritrea's coastline is about 1720 km long, about 1155 km of which lies along the continental shore and 565 km around some 350 islands. The total area of Eritrea's exclusive economic zone (EEZ) is about 77,700 km². This part of the Red Sea is known for its wide continental shelf, which is dotted by a large number of low-lying coralline islands. Most of the islands are located in the Dahlak Archipelago, and they are scattered from 20–160 km off Eritrea's main port of Massawa (Fig. 1). Eritrea's continental shelf area is about 56,000 km², which is the largest of all the countries along the Red Sea. The shelf area around the Dahlak

archipelago, where most of the coral reefs are concentrated, represents about 25% of Eritrea's total continental shelf. The total area covered by coral reefs along the Eritrean coast is about 3,260 km² (Spalding et al., 2001). About 20% of the total shelf area is less than 30 m deep, and according to FAO's Code of Conduct for Responsible Fishing, is off-limits to the fishing operations by industrial fisheries (Guidicelli, 1984).

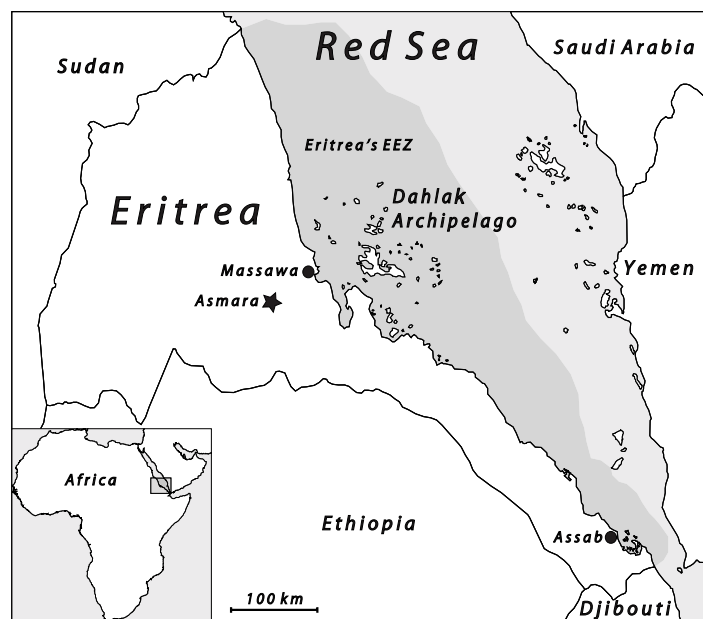

Figure 1. Map of Eritrea showing the islands of the Dahlak Archipelago and the fishing harbors of Massawa and Assab.

The coral reefs of the Red Sea are known for their diverse array of fish and invertebrate populations, providing home for over 1000 species of fish and over 200 species of corals (Ormond and Edwards, 1987). According to SeaWiFS¹ global primary productivity estimates, the Red Sea is generally considered moderately productive (150–300 gC·m⁻²·year⁻¹) (Getahun, 1998). The year-round high temperatures of the Red Sea result in the formation of a permanent thermocline, inhibiting recirculation of nutrients from the bottom of the sea to surface layers, and consequently lowering primary productivity (Edwards, 1987). In addition, due to the arid climate of the region, there is little nutrient input to the Red Sea through river runoff. Nevertheless, the southern part of the Red Sea is more

¹ <http://oceancolor.gsfc.nasa.gov/SeaWiFS/>

productive due to the advection of nutrient-rich waters through Bab El Mandab, driven by monsoon winds (Getahun, 1998; Sheppard, et al. 1992). Much of the primary production is actually recycled and dissipated in the characteristically complex food webs of coral reef ecosystems. As a result, little of the primary production is converted to harvestable biomass (Arias-Gonzalez, 1997). Nevertheless, despite their relatively small contribution to fish production in global terms, the coral reefs of the Red Sea could support important artisanal fisheries, potentially providing food and livelihood earnings for tens of thousands of coastal communities² (Head, 1987). Alongside, the continental shelf outside the coralline zones offers favorable fishing grounds for bottom trawl fisheries, while the overlying fish communities form an important resource-base for the development of pelagic fisheries (Reynolds et al., 1993).

Because of scarcity of financial and human resources, quantitative assessments of the potential for fisheries of the Eritrean Red Sea have rarely been carried out, with most studies having been undertaken in the 1960s–1980s (Sanders and Morgan, 1989; Morgan, 2006). Most estimates of potential yield made thus far have been based on catch rates, on some experimental fishing, or on extrapolation from other areas. These estimates range from 36,000 to 79,500 tonnes·year⁻¹. The latest stock assessment survey for the Eritrean fisheries was undertaken in 1996 (Morgan, 2006). Earlier estimates indicated that small pelagic resources, mainly sardines, such as Spotback herring *Herklotsichthys punctatus*, and anchovies, such as Baelama anchovy, *Thryssa baelama* and Shorthead anchovy, *Encrasicolina heteroloba*, accounted for the majority of the total maximal sustainable yield (MSY), making up about 50,000 tonnes·year⁻¹ (Grofit, 1971). MSY for demersal resources, including – in a decreasing order – lizardfishes (*Saurida tumbil* and *Synodis* spp.), threadfin breams (Nemipteridae), barracudas (*Sphyraena* spp.), snappers (Lutjanidae), and groupers (Serranidae), was estimated at around 15,000–20,000 tonnes·year⁻¹, while that for large pelagic (including tunas, Scombridae) were estimated at around 7,000 tonnes·year⁻¹. The rest of the total MSY estimated comprises of shrimp (500 tonnes·year⁻¹), lobster and other minor species (Morgan, 2006).

3.2. History and current state of exploitation

The coral reef resources of Eritrea have been exploited almost exclusively by small-scale artisanal fisheries (Reynolds et al., 1993). Unlike most fisheries around the world, the

² Salih, S.A., 1998. Available at the Ministry of Fisheries library, P.O. Box 18, Massawa, Eritrea.

developments in the Eritrean artisanal fisheries of the past (1950s–1990s) were largely governed by political and socio-economic circumstances of that period, rather than by biological or physical factors (Morgan, 2006). These fisheries first began as subsistence activities using canoes and small plank boats, but they expanded with the introduction of motorized boats in the 1960s (Reynolds et al., 1993). Until the beginning of the 1970s, the artisanal fisheries sector was in a steady state of development and was an important part of the Eritrean economy. In 1970, the artisanal fleet size was estimated at some 800 wooden motor boats. Fishing techniques included beach-seining, hand-lining and, to a lesser extent, troll-lining, shark gillnetting, and long-lining (Grofit, 1971). Alongside, there was a well-developed network for the distribution and marketing of fish and fish products, both to local and foreign markets. In addition to fish sold fresh in the local markets, fresh and frozen fish were exported to many countries. The export of shark fins to the Far East was also an important commercial activity. Moreover, small pelagic fishes were processed into fishmeal or sun-dried for export to European and Far East markets (Aubray, 1975).

By the beginning of the 1970s, most of the existing fishing harbors and fishing vessels were destroyed as a result of Eritrea's war for independence. Having been left without outlets for their production, fishers increasingly turned to other activities. Fish production by Eritrean fishers turned predominantly to sun-dried salted shark, shark fins and shark meat (Salih, 1998). The small pelagic fishery for sardine and anchovy continued to be the main component of the artisanal fisheries production (Morgan, 2006). However, by the end of the 1970s, at the height of the war, the artisanal fisheries were brought to a virtual standstill (Reynolds et al., 1993; Salih, 1998). These fisheries were launched into a renewed development only in 1991 after the end of the war for independence.

Meanwhile, there were active industrial fisheries mainly exploiting offshore pelagic and demersal stocks, whose annual harvests were in excess of 20,000 tonnes in the 1950's (Fig. 2). The industrial fishing fleet in the sixties comprised of inshore trawlers (50–120 HP), off-shore trawlers (150–400 HP) and some handliners (Ben Yami, 1975; Aubray, 1975). About 80% of their landings consisted of small pelagics, mainly sardines and anchovies), about 15 % demersal fishes and 5% sharks (Sanders and Morgan, 1989). The demersal catches mainly consisted of lizardfishes (*Saurida tumbil* and *Synodis* spp.) and threadfin breams (Nemipteridae). Indeed, just as the artisanal fisheries, the industrial fisheries were brought to a halt by the end of the 1970s, owing to the growing instability in the area in that period. Presently, the industrial fisheries have been operating only sporadically, and are mainly dependent of foreign (mainly Egyptian) fishing companies operating under

temporary agreements – there is still limited local capacity. Since 2002, the industrial fishery has been moving from being completely dependent on foreign fishing companies to nurturing home-based companies involved in long-line, trawl, and purse-seine fisheries. Yet, the total annual catch for the industrial fisheries has mostly been less than 10,000 tonnes·year⁻¹, which is far lower than the maximum sustainable yield estimated for these fisheries (data from Eritrean fisheries database). Because the shallow waters are declared off-limits to trawl fishing by industrial fisheries, the interaction between artisanal and industrial fisheries is very low.

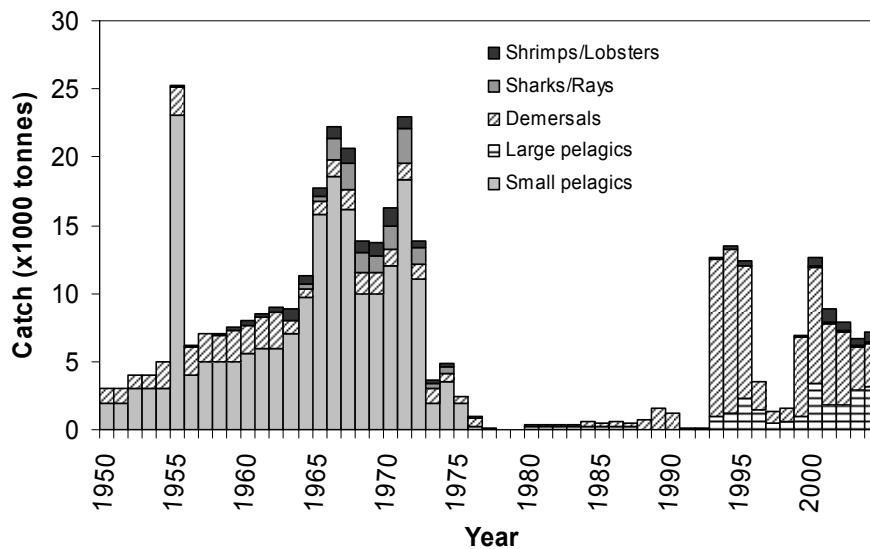

Figure 2. Historical landings from the artisanal and industrial Red Sea fisheries of Eritrea reconstructed from Reynolds (1993) (1955, 1963–78), FAO (1983) (1950–54, 1979–90), and data from this study (1991-2003).

The artisanal fisheries, on the other hand, have witnessed a steady development since they were relaunched in 1991, even though they are also operating at a lower level than is required to achieve maximum sustainable yield. By 2003, these fisheries consisted of some 3000 fishers and operated a fleet of over 600 hours and sambucks (Morgan, 2006). Currently, The artisanal fisheries comprise of mostly hand-lining or gillnetting operations using two types of wooden boats, which vary in size and engine power: the smaller hours and the larger sambucks (Fig. 3). Hours are small boats of 4 to 9 m in length that are

equipped with an out-board engine (ca. 35 HP), operated by a crew size of 5–8. Sambucks are 12 to 17 m boats with an inboard engine (ca. 50HP), with a crew size of 6–12 people.

In these fisheries, houris are used for gillnet fishing more often than sambucks, apparently because they have lower gunwales, making them more suitable for setting and retrieving gillnets. On the other hand, sambucks, being larger in size, are more seaworthy for long-distance and prolonged fishing trips, mainly involving hook and line fishing. In addition, sambucks are considered more economical for longer trips because they run on the lower-price diesel, unlike houris, which run on petrol. Both the houri and sambuck fisheries primarily target reef fish and mid-sized and large pelagic fish. As a result, their catches have predominantly been composed of the highly vulnerable long-lived, high trophic level, piscivorous species (Ghebremichael and Haile, 2006).

By the end of the 1990s, species and size composition of catches suggested a low level of exploitation of the fish communities³. Large specimens of highly valued demersals such as snappers and jobfishes (Lutjanidae), groupers (Serranidae), and emperors (Lethrinidae) smaller proportion of pelagics, mainly mackerels (Scombridae), dominated the catch. Nevertheless, an increase in fishing pressure with the continued expansion of the fisheries is expected to lead to a decline in CPUE of particularly the largest and most vulnerable species (van Densen, 2001).

In view of the above, although Eritrea's fisheries are supposedly at the initial stages of development, a framework for their sustainable development and management needs to be developed to prevent overexploitation of the resources. The management of fisheries resources is currently based on an open access system for the artisanal fishers and a regulated access for the industrial fisheries, both of which operate under a licensing system. Landings are monitored through a routine collection of catch and fishing effort statistics and this could provide an important basis for the assessment of fish stocks and fisheries. However, the large amounts of fish taken to Yemen by Eritrean fishers or Yemeni fishers operating in Eritrea's waters have not been effectively regulated (Moussalli and Haile, 2001). Experience with fisheries elsewhere under similar circumstances over the past few decades suggests an eventual depletion of valuable concentrations of resources and shift towards the capture of small-sized species as fisheries continue to expand (Koslow et al,

³ Hartmann, S. 1998. Available at the Ministry of Fisheries Library, P.O.Box 18, Massawa, Eritrea.

1988). This underlines the need for the development of an effective assessment and management of the artisanal fisheries.



Figure 3. The two most commonly used types of boats in the artisanal fisheries, houri (top) and sambuck (bottom). Photos: L.A.J. Nagelkerke.

4. Objectives and outline of the thesis

Apart from some descriptive analysis of catch and effort data, no thorough investigation of the sustainability of existing fishing patterns has been made for the artisanal fisheries of Eritrea since it was relaunched in 1991 (Morgan, 2006). However, since major changes in fish community could occur even at low levels of fishing, it is important to monitor the

state of fisheries and fish stocks in the artisanal fisheries at their initial stages of development. Moreover, the concentration of fishing effort in the artisanal fisheries on selected species of fish could result in not only rapid over-exploitation of target species, but also major changes in fish community structure through top-down effects of fishing on ecosystems. The main objective of this study is thus to evaluate the sustainability of existing fishing practices in the artisanal fisheries. However, like most reef fisheries around the world, only limited research has been conducted on the state of fish stocks of Eritrea, thus there is limited fishery-independent data for the assessment of fishing effects. **Therefore, the present study assesses the state of fish stocks based on fishery-dependent data, while simultaneously examining the capabilities and limitations in the use of existing data recording system to evaluate the state of fish stocks. Moreover, this study uses an ecosystem simulation model to examine the reliability of using trends derived from official catch and effort statistics as indicators of the state of fish stocks.**

Specifically, the second chapter uses catch and effort statistics from the artisanal fisheries of Eritrea: to **describe the fisheries** in terms of developments in annual yield and effort; to determine if there were significant **trends** in catch rate and composition over the years; and to explore if there were any **changes in fish community** underlying trends in catch composition. The third chapter investigates the importance of **changes in socio-economic circumstances** within the artisanal fisheries as potential causes of changes in catch rate and composition. In so doing, it shows if changes in catch rate and composition reflect actual changes in fish abundance or are merely results of non-biological changes. For this purpose, multivariate statistical analyses were used to elucidate the relationships between changes in catch composition and relevant socio-economic variables. The fourth chapter explores more effective ways of using catch data in order to gain a better insight into the state of fisheries and fish stocks. Here, the thesis determines the consequences of **aggregation of species catch data** into different levels (families, family groups, total catch rate) for the **statistical power** to detect trends in catch rate. In addition, this chapter examines the consequences of the reduction in random variability in catch rates upon aggregation of data for the optimization of the catch and effort sampling strategy in the artisanal fisheries. In the fifth chapter, an Ecopath with Ecosim **trophic model** is constructed using – rather limited – ecological data on the coral reef and adjacent ecosystems to describe the structure and functioning of the coral reef ecosystems supporting the artisanal fisheries. This model is used for a **retrospective examination of trends** to determine whether the existing levels of fishing as suggested by reports and/or

anecdotes could possibly be sustained by the production rate of the reef fish assemblages as estimated by the model. Temporal simulations using Ecosim are also applied to verify if fishery-induced changes in yield and abundance of reef-associated fishes implied by official statistics are likely, given the existing levels of fishing intensity. In addition, the model is used to explore optimal fishing scenarios for the artisanal fisheries in light of the ecosystem-level impacts of fishing. Finally, chapter six discusses the findings from this study and their implications for the management of reef fisheries, while exploring possible ways forward for the study of reef fisheries in Eritrea.

References

- Allison, E.H., Ellis, F., 2001. The livelihood approach and management of small-scale fisheries. *Marine Policy* 25: 377-388.
- Arias-Gonzalez, J. E., Delesalle, B., Salvat, B., Galzin, R., 1997. Trophic functioning of the Tiahura reef sector, Moorea Island, French Polynesia. *Coral Reefs* 16, 231-246.
- Aswani, S. and Hamilton R.J., 2004. Integrating indigenous ecological knowledge and customary sea tenure with marine and social science for conservation of bumphead parrotfish (*Bolbometopon muricatum*) in the Roviana Lagoon, Solomon Islands. *Environmental conservation* 31, 69-83.
- Aubray, R., 1975. The fisheries of Ethiopia. An economic study. FAO, Rome, 23 pp.
- Ben Yami, M., 1964. Report on the fisheries in Ethiopia. Ministry for Foreign Affairs, Department for International Cooperation. Jerusalem, State of Israel.
- Bundy, A., Pauly, D., 2001. Selective harvesting by small-scale fisheries: ecosystem analysis of San Miguel Bay, Philippines. *Fish. Res.* 53, 263-281.
- Caddy, J. F., Csirke, J., Garcia, S. M., Grainer, R. J. R., 1998. How pervasive is "Fishing Down Marine Food Webs"? *Science* 282, 183.
- Campbell, S.J., Pardede, S.T., 2006. Reef fish structure and cascading effects in response to artisanal fishing pressure. *Fish. Res.* 79, 75-83.
- Christensen, V., Pauly, D., 2004. Placing fisheries in their ecosystem context, an introduction. *Ecol. Model.* 172, 103-107.
- Dalzell, P., 1998. The role of archaeological and cultural-historical records in long-range coastal fisheries resources management strategies and policies in the Pacific islands. *Ocean coast. Manage.* 40, 237-252
- Dulvy, N.K., Freckleton, R.P., Polunin, N.V.C., 2004. Coral reef cascades and the indirect effects of predator removal by exploitation. *Ecology Letters* 7, 410-416.
- FAO, 1983. Fishery country profile: Ethiopia. Rome, FAO (FID/CP/ETH,REV.1).

- FAO, 2002. The State of World Fisheries and Aquaculture. Food and Agriculture Organization of the United Nations, Rome.
- Getahun, A., 1998. The Red Sea as an extension of the Indian Ocean. In: Sherman, et al., (Eds.), Large Marine Ecosystems of the Indian Ocean: Assessment, Sustainability, and Management. Blackwell Science, Oxford, pp 277-283.
- Ghebremichael, A. and Haile. S., 2006. Commercial fishes of the Eritrean Red Sea. Apex Publishing Ltd., Essex, England, 266 pp.
- Grofit, E., 1971. The Red Sea fisheries of Ethiopia. Centre for Agricultural Cooperation with Developing Countries, Ministry of Agriculture, Isreal, 82 pp.
- Guidicelli, M., 1984. The Ethiopian fisheries: situation, development needs and opportunities. Report prepared for the Fishery Planning and Development Project. Field Document (FI/DP/ETH/82/016). FAO, Rome, 157 pp.
- Hartmann, S., 1998. Artisanal landings by motorized vessels in Massawa in recent times; 1994–1997. Ministry of Fisheries, Massawa, Eritrea. 41pp+addenda.
- Hawkins, J.P., Roberts, C.M., 2003. Effects of artisanal fishing on Caribbean coral reefs. Conservation Biology 18, 215-226.
- Head, S., 1987. Red Sea fisheries. In: Edwards, A.J., Head, S.M. (Eds.), Red Sea: Key Environments. Pergamon Press, Oxford, pp. 363–382.
- Jennings, S., Lock, J.M., 1996. Population and ecosystem effects of reef fishing. In: Polunin, N.V.C., Roberts, C.M. (Eds.), Reef Fisheries. Chapman and Hall, London, pp 193-218.
- Jennings, S., Polunin, N.V.C., 1996a. Effects of fishing effort and catch rate upon the structure and biomass of Fijian reef fish communities. Journal of Applied Ecology 33: 400-412.
- Jennings, S., Polunin, N.V.C., 1996b. Fishing strategies, fishery development and socioeconomics in traditionally managed Fijian fishing grounds. Fish. Manage. Ecol. 3, 335-347.
- Jennings, S., Polunin, N.V.C., 1997. Impacts of predator depletion by fishing on the biomass and diversity of non-target reef fish communities. Coral Reefs, 16, 71-82.
- Jennings S., Reynolds, J.D., Polunin, V.C., 1999. Predicting the vulnerability of tropical reef fishes to exploitation with phylogenies and life histories. Conservation Biology 13, 1466-1475.
- King, M.G., Lambeth, L., 2000. Fisheries Management by Communities: A Manual on Promoting the Management of Subsistence Fisheries by Pacific Island Communities. Secretariat of the Pacific Community, Noumea.
- Koslow, J.A., Akiken, K., Auil, S., Clementson, A., 1994. Catch and effort analysis of the reef fisheries of Jamaica and Belize. Fischeires Bulletin 92: 737-747.
- Koslow, J.A., Hanley, F., Wicklaud, R., 1988. Effects of fishing on reef fish communities at Pedro Bank and Port Royal Cays, Jamaica. Mar. Ecol. Prog. Ser. 43:201-212.

- Kronen, M., 2004. Fishing for fortunes? A socio-economic assessment of Tonga's artisanal fisheries. *Fish. Res.* 70, 121-134.
- Kuster C., Vuki V.C., Zann, L.P., 2005. Long-term trends in subsistence fishing patterns and coral reef fisheries yield from a remote Fijian island. *Fish. Res.* 76, 221–228.
- Lunn, K.E., Dearden, P., 2006. Monitoring small-scale marine fisheries: An example from Thailand's Ko Chang archipelago. *Fish. Res.* 77, 60-71.
- Magnusson, K.G., 1995. An overview of the multispecies VPA – theory and applications. *Rev. Fish Biol. Fish.* 5, 195–212.
- Marasco, R.J., Goodman, D., Grime, C.B., Lawson, P.W., Punt, A.E., Quinn II, T.J., 2007. Ecosystem-based fisheries management: some practical suggestions. *Can. J. Fish. Aquat. Sci.* 64, 928-939.
- McClanahan, T. R., Kakamura, A. T., Muthiga, N. A., Gilagabher Yebio, M., Obura, D., 1996. Effects of sea urchin reductions on algae, coral and fish populations. *Cons. Biol.* 10:136-154.
- McClanahan, T.R., Shafir S.H., 1990. Causes and consequences of sea urchin abundance and diversity in Kenyan coral reef lagoons. *Oecologia* 83:362-370
- McClanahan T.R., Muthiga N.A., Kamukuru A.T., Machano H., Kiambo R.W., 1999. The effects of marine parks and fishing on coral reefs of northern Tanzania. *Biol. Cons.* 89, 161-182.
- Morgan, G., 2006. Country review: Eritrea. In: De Young, C. (Ed.) Review of the state of world marine capture fisheries management: Indian Ocean. FAO Fisheries Technical Paper. No. 488, FAO, Rome, 458 pp.
- Moussalli, E., Haile, T., 2001. Ex post Evaluation of the Semhar Fisheries Rehabilitation Project ERI/92/001(UNDP) ERI/92/C01 (UNCDF) and Capacity Building for the National Marine Resources Programme ERI/94/001 (UNDP). UNDP, 53 pp.
- Mumby, P.J. et al., 2006. Fishing, trophic cascades, and the process of grazing on coral reefs. *Science* 311, 98-101.
- Munro, J.L., 1996. The scope of tropical reef fisheries and their management. In: Polunin, N.V.C., Roberts, C.M. (Eds.), Reef Fisheries. Chapman and Hall, London, pp 1-14.
- Myers, R. A., Worm, B., 2003. Rapid worldwide depletion of predatory fish communities. *Nature* 423, 280-283.
- Ormond, R., Edwards, A., 1987. Red Sea fishes. In: Edwards, A., Head, S. (Eds.), Red Sea. Pergamon Press, Oxford, pp 252-287.
- Pauly, D., 1994. On the sex of fish and the gender of scientists: essays in fisheries science. Chapman & Hall, London, 250 pp.

- Reynolds, J.E., Appleton, J., Bellemans, M.S., Bonzon, A., Christy, L.C., 1993. The fisheries of Eritrea, part. 1: Sector review. part. 2: Proposed national fisheries strategy and development program. Terminal Report, FI:FAO/TCP/ERT/2251. FAO, Rome.
- Russ, G.R., 2002. Yet another review of marine reserves as reef fishery management tools. In: Sale, P.F. (Ed.), *Coral Reef Fishes*. Academic Press, San Diego, pp 421-443.
- Ruttenberg, B.I., 2001. Effects of artisanal fishing on marine communities in the Galapagos Islands. *Cons. Biol.* 15, 1691-1699.
- Sadovy, Y.J., 2005. Trouble on the reef: the imperative for managing vulnerable and valuable fisheries. *Fish and Fish.* 6, 167-185.
- Salih, S.A., 1998. Report on a community-based frame survey. Research and Training Division, Ministry of Fisheries, Eritrea, 29 pp.
- Sanders, A.P.L., Morgan, G.R., 1989. Review of the fisheries resources of the Red Sea and the Gulf of Aden. FAO Fisheries Technical Paper. No. 304. FAO, Rome, 138 pp.
- Sheppard, C.R.C., Price, A., Roberts, C., 1992. *Marine Ecology of the Arabian Region: Patterns and processes in extreme tropical environments*. Academic Press, Cambridge, 359 pp.
- Spalding, M.D., Ravilious, C, Green, E.P., 2001. *World Atlas of Coral Reefs*. University of California Press, Berkeley, USA.
- Sparre, P., 1991. Introduction to multispecies virtual population analysis. *ICES Mar. Sci. Symp.* 193, pp. 12-21.
- Sparre, P., Venema, S.C., 1998. Introduction to tropical fish stock assessment, Part 1, manual. FAO Fish. Tech. Pap. No. 306.1, Rev. 2. FAO, Rome, 407 pp.
- Van Densen, W.L.T., 2001. On the perception of time trends in resource outcome. Its importance in fisheries co-management, agriculture and whaling. PhD thesis, Twente University, Enschede, the Netherlands. 299 pp.
- Vasconcellos, M., Cochrane, K., 2005. Overview of world status of data-limited fisheries: Inferences from landing statistics. In: Kruse, G.H., Gallucci, V.F., Hay, D.E., Perry, R.I., Peterman, R.M., Shirley, T.C., Spencer, P.D., Wilson, B., Woodby, D. (Eds), *Fisheries Assessment in Data-Limited Situations. Proceedings of the 21st Lowell Wakefield fisheries symposium*. Fiarbanks, Alaska, pp 1-20.
- Villanoy, C.L., Junio, A.R., Menez, L.A., 1988. Fishing mortality rates of giant clams (Family Tridacnidae) from the Sulu Archipelago and Southern Palawan, Philippines. *Coral Reefs* 7, 1-5.
- Wells, S., 1997. *Giant Clams: Status, Trade and Mariculture, and the Role of CITES in Management*. IUCN, Gland, Switzerland and Cambridge, UK. ix + 77 pp.

CHAPTER 2

Rapid shifts in catch composition in the artisanal Red Sea reef fisheries of Eritrea

Iyob Tschaye^{1,2}, Marcel A.M. Machiels¹ & Leopold A.J. Nagelkerke¹

¹Aquaculture and Fisheries Group, Wageningen University, Wageningen Institute of Animal Sciences, Marijkeweg 40, 6709 PG Wageningen, the Netherlands.

²Department of Marine Sciences, University of Asmara, P.O. Box 1220, Asmara, Eritrea

Abstract

Shifts in catch composition were registered for the artisanal fisheries of Eritrea, which were launched into a renewed development in 1991 after the end of the independence war. Our analysis of catch and effort data showed that total fishing effort as well as total annual catch increased more than twofold from 1996 to 2002. Overall CPUE remained unchanged despite the expansion of the fisheries, suggesting that the fisheries are still at an early stage of development. However, our analysis at a lower taxonomic level revealed that the CPUE for snappers (Lutjanidae), emperors (Lethrinidae), and sharks (Elasmobranchii) decreased, while that for jacks (Carangidae), tunas (Scombridae) and barracudas (Sphyraenidae) increased over the years. As a result, the species composition of the catches shifted toward a higher proportion of the lower-value pelagics (from ca. 30% in 1996 to ca. 70% in 2002), implying a change in the underlying fish community structure. The changes in CPUE could not be attributed to changes in spatial allocation of effort or to changes in gear or boat used, making it unlikely that they were caused by changes in fishing strategies. Yet, the decline in CPUE of demersals does not necessarily reflect a proportional decline in fish abundance, and could possibly be due to “hyperdepletion”, particularly given the relatively low fishing intensity. Nevertheless, our results are consistent with other studies suggesting that stocks of reef-associated demersal fishes are highly vulnerable to fishing and can decline even at the early stages of fisheries. Therefore, the changes in CPUE in the reef fisheries of Eritrea could indeed represent actual biomass changes, with potentially important ecological consequences. Furthermore, the effects of fishing in the artisanal fisheries could even become more severe if market conditions improve leading to the activation of latent fishing capacity, which was found to make up about 75% of the registered fleet.

Keywords: catch composition; catch effort data recording system; Eritrea; fishing effort; reef fisheries; trends.

1. Introduction

The reef-associated fish resources of Eritrea's Red Sea coast have mainly been exploited by artisanal fisheries. These fisheries were launched into a renewed development in 1991 after the end of a decades-long standstill, which was caused by the war for independence of Eritrea (Reynolds et al., 1993). Since major changes in reef fish community structure can take place even at the initial stages in the development of fisheries (Dulvy et al., 2004a,b), the onset of reef fisheries in the Eritrean Red Sea presents an opportunity for exploring the effects of fishing on fish community structure in a newly developing fishery.

Most fishing operations in the Eritrean artisanal fisheries are carried out using small traditional wooden boats (Reynolds et al., 1993). These fisheries primarily target reef fish and mid-sized and large pelagic fish. As a result, catches are predominantly composed of long-lived, high trophic level, piscivorous species (Ghebremichael and Haile, 2006). Despite continued efforts by the Eritrean Ministry of Fisheries to expand the fisheries, the artisanal fisheries are presumed to have remained under-developed, and fish stocks have apparently been lightly exploited. The total annual catch reported for the artisanal fisheries rarely exceeded 1000 tonnes·year⁻¹ (this study), an amount which is less than 10% of the potential sustainable yield estimated for the reef fisheries. Similarly, the total annual catch for the artisanal and (an intermittent) industrial fishery combined has been less than a fifth of the maximum sustainable yield, which was estimated to be between 36,000 and 79,500 tonnes·year⁻¹ (Sanders and Morgan, 1989; Ghebremichael and Haile, 2006) (Table 1). Some preliminary studies have also suggested a low level of exploitation for these fisheries over the years, citing a constant aggregate catch per unit of effort (CPUE)¹ (Moussali & Haile, 2001). This claim has further been evidenced by the predominance of long-lived, high trophic level, piscivorous species in the catches (Habte, 2003).

On the other hand, the total annual catch reported for the artisanal fisheries has been increasing over the years (this study). In addition, anecdotal evidence suggests that large amounts of catch are taken illegally to Yemen, where market circumstances are apparently better than in Eritrea. These catches are believed to be two thirds to three quarters as much as the total annual catch in the artisanal fisheries (Moussalli and Haile, 2001). When these amounts are included, the actual level of fishing in the artisanal fisheries is found to be much higher than is officially reported. Besides, even if limited, the fishing practices in

¹ Hartmann, S. 1998. Available at the Ministry of Fisheries Library, P.O.Box 18, Massawa, Eritrea.

these fisheries are highly selective, mainly targeting the most vulnerable predatory fishes. This can have potentially more serious consequences for the sustainability of fisheries and fish stocks. Overall, these circumstances suggest that the existing fishing practices may be unsustainable, underling the need for a more effective assessment and management of the artisanal fisheries.

Table 1. Estimates of the maximum sustainable yield (MSY) from Eritrean marine waters (in 1000 tonnes·year⁻¹) derived from several independent studies.

Resource	MSY ^{a,b}	MSY ^c	MSY ^d	MSY ^e
Demersal fish	10.0–15.0	8.5	18.0	17.0 + 5.0 (reef)
Shrimp	0.5	0.5	0.5	0.5
Spiny lobster (whole)	0.5	–	0.5–1.0	0.5
Coastal pelagics	50.0	25.0	25.0–50.0	24.0
Neritic and oceanic pelagics	–	–	5.0	6.0
Sharks	5.0	2.0	2.0 – 5.0	5.0
Total	66.0–71.0	36.0	51.0–79.5	58.0

^a Grofit (1971). Available at the Ministry of Fisheries Library, P.O.Box 18, Massawa, Eritrea.

^b Aubray (1975).

^c Gaudet (1981). Available at the Ministry of Fisheries Library, P.O.Box 18, Massawa, Eritrea.

^d Guidicelli (1984).

^e Antoine et al. (1998). Available at the Ministry of Fisheries Library, P.O.Box 18, Massawa, Eritrea.

The assessment and management of the artisanal reef fisheries, like all reef fisheries, poses special challenges owing to the high diversity of target and non-target fish and invertebrates and the fragility of the ecosystem (Pauly and Murphy, 1982). This is particularly so given the concentration of fishing effort on the highly vulnerable predatory species of fish, which could not only result in rapid over-exploitation of the target species (McClanahan et al., 2002; Wilkinson, 2002; Dulvy et al., 2004b, Sadovy, 2005), but also have far-reaching consequences for the overall community structure through top-down effects of fishing on ecosystems (Jennings and Lock, 1996; Parsons 1996; Dulvy et al., 2004a). Given the complex nature of the fish communities and the fisheries, an effective assessment and management of reef fisheries requires wide range of information on the structure and functioning of the reef fish assemblages.

Just as in most multispecies, multigear fisheries in the developing world (Christensen, 1996; Larkin, 1996; Bundy and Pauly, 2001), only limited research has been conducted thus far on the state of fish stocks and fisheries in Eritrea, rendering the fisheries data-poor. Therefore, the scarcity of data in these fisheries precludes the application of traditional assessment methods, which are often applied in the management of temperate fisheries (Magnusson, 1995; Sparre, 1991). In such a data-poor situation, the use of catch and effort data is usually the most viable option for evaluating the status of fisheries and fish stocks (Sparre and Venema, 1998, Vasconcellos and Cochrane, 2005). The present study thus draws on fisheries-dependent data to assess the state of fisheries and fish stocks in Eritrea's Red Sea coast.

In the use of fisheries-dependent data to monitor the state of fish stocks, changes in catch rate are assumed to reflect changes in fish abundance. However, changes in catch rate could be confounded by changes in fish targeting strategies, potentially leading to spurious conclusions concerning the state of fish stocks. Therefore, catch rates can only be used as valid indicators of abundance if they are adjusted to account for changes in fishing strategies (King, 1995; Caddy et al., 1998; Myers and Worm, 2003). In this study, while taking the limitations in the use of fishery-dependent data into account, we use catch and effort records from the Eritrean artisanal fisheries to (1) describe the fisheries in terms of developments in annual yield and effort; (2) determine if there were significant trends in catch rate and composition over the years and (3) examine if there were any changes in the fish community underlying trends in catch composition.

2. Materials and methods

2.1. Characteristics of the fisheries

The fishing activities in the artisanal fisheries mainly take place in inshore waters along Eritrea's Red Sea coast. Eritrea's Red Sea coast is approximately 1,720 km long, about 1,155 km of which lies along the continental shore and about 565 km around some 350 islands (Fig. 1). Most of the fishing operations are concentrated around the islands in the Dahlak archipelago, a group of more than 200 islands scattered from 20 to 160 km from Eritrea's main port of Massawa. The shelf area around the major fishing grounds of the Dahlak archipelago represents about 25% of Eritrea's total continental shelf area of 56,000 km². About 20% of the total shelf area, where most of the artisanal fisheries take place, is less than 30 m deep (Guidicelli, 1984). According to FAO's Code of Conduct for Responsible Fishing, these shallow waters are off-limits to trawl fishing by industrial

fisheries (Guidicelli, 1984). The Ministry of Fisheries enforces these area restrictions by dispatching inspectors aboard trawlers on every fishing trip (Kelleher, 2005; I.T. personal observation). Therefore, the interaction between artisanal and industrial fisheries is considered negligible.

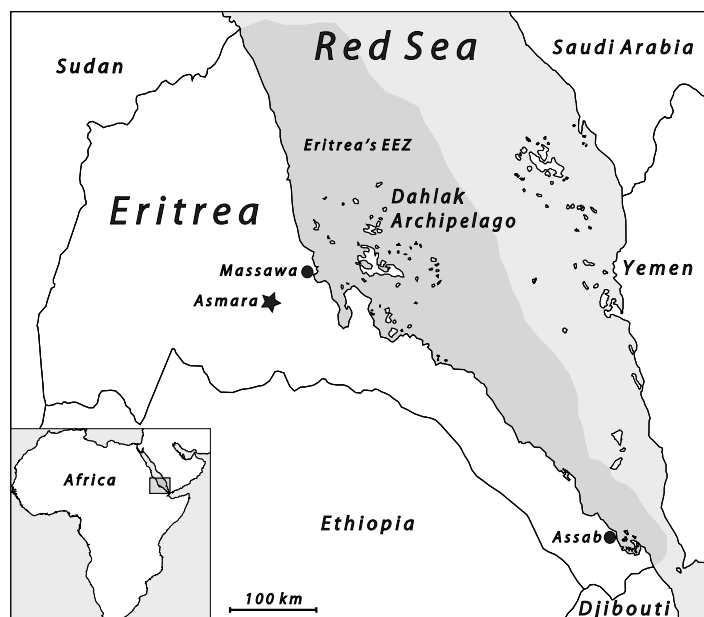

Figure 1. Map of Eritrea showing the islands of the Dahlak Archipelago and the fishing harbors of Massawa and Assab.

In the artisanal fisheries, the fishing operations are mainly carried out using two types of boats: the smaller *houris* and the larger *sambucks* (Table 2). The main types of fishing gear used in these fisheries are gillnets, hook and line or a combination of both. Fishers use gillnets ranging from 20–200 m in length and 1.5–2.5 m in height, with a bar mesh size of 10–12 cm. The number of gillnets per fishing trip varies from 6 to 10.² The hooks used in these fisheries are 2–2.5 cm wide and 5–7 cm long, used with a single hook per line. Fishers use gillnets and hook and line mainly for the capture of pelagic and demersal fish, respectively. Alongside the motorized fishing operations, there are limited canoe fisheries operating in nearshore waters in the vicinity of Massawa, with their catch accounting for

² Salih, S.A., 1998. Available at the Ministry of Fisheries library, P.O. Box 18, Massawa, Eritrea.

only a small proportion of the total weight of annual catches in the artisanal fisheries (<2%) (this study).

Table 2. Characteristics of the small-scale artisanal fisheries in the Eritrean Red Sea, representing the situation in 2002 (data from this study).

Boat type	Houri	Sambuck
Number of boats	306	152
Length (meters)	4–9	12–17
Engine	Outboard, petrol, 35 HP	Inboard, diesel, 50HP
Crew members	5–8	6–12
Number of days per trip	5–9	6–12
Distance of fishing grounds	<100km	To Eritrea's EEZ limits

In these fisheries, houris are used for gillnet fishing more often than sambucks, apparently because they have lower gunwales, making them more suitable for setting and retrieving gillnets¹. Fishers normally carry out gillnet fishing at night for a number of consecutive days, and mainly during new moon, with nets set at dusk and retrieved at dawn. On the other hand, sambucks, being larger in size, are more preferable for long-distance and prolonged fishing trips, mainly involving hook and line fishing. In addition, sambucks are considered more economical for longer trips because they run on the lower-price diesel, unlike houris, which run on petrol. Both houris and sambucks are equipped with a fish hold, which is stocked with chipped ice before the boats set out for fishing. The boat's fish hold size and the ice-melting rate limit the length of fishing trips to usually not more than 12 days. Given adequate supplies, every boat makes two to three fishing trips per month on average.³

The fishing capacity within the artisanal fisheries has been rising since the fisheries were launched in 1991, with the total number of registered boats exceeding 450 in 2002 (Table 2). Nevertheless, the existing fishing effort has mainly been concentrated on commercially most important fishes. The landings are thus mainly made up of (a) snappers (*Lutjanidae*), such as two-spot red snapper (*Lutjanus bohar*), Humpback red snapper (*Lutjanus gibbosus*), and Humphead snapper (*Lutjanus sanguineus*); (b) groupers (*Serranidae*), including Brown-spotted grouper (*Epinephelus chlorostigma*), and Malabar grouper

³ Ministry of Fisheries. 2002. Available at the Ministry of Fisheries Library, P.O. Box 18, Massawa, Eritrea.

(*Epinephelus malabaricus*); (c) emperors (Lethrinidae), representing Longface emperor (*Lethrinus elongatus*), and Goldband jobfish (*Pristipomoides multidens*); and (d) mackerels and tunas (Scombridae), including Narrow-barred Spanish mackerel (*Scomberomorus commerson*) and Longtail tuna (*Thunnus tonggol*) (Ghebremichael and Haile, 2006).

In these fisheries, most of the catches can be readily accounted for, because (1) almost all catches are landed at the fishing harbors designated by the Ministry of Fisheries, mainly in Massawa and Assab, where the major markets are located; (2) landings rarely take place in other places as most of the coastal areas, owing to the arid climate of the region, are sparsely populated; (3) just as in most Red Sea artisanal fisheries, discards are negligible in the artisanal fisheries of Eritrea, making it unlikely for catches to be under-reported in official statistics (Kelleher, 2005). (4) fish is not an important part of the diet in Eritrea, making self-consumption of fish by fishers unlikely to result in under-reporting of catches²; and (5) most of the catches are destined for export markets as there is limited local demand, making it necessary for fishers to deliver their catches to the government designated fishing harbors. Nevertheless, while all fishing is carried out under licenses issued by the Ministry of Fisheries, the supposedly large amounts of catch taken illegally to Yemen constitute a potentially large amount of unreported catches (Moussalli and Haile, 2001).

2.2. The database

The present study is based on the catch and effort data recording system (CEDRS) for the artisanal fisheries, as instituted by the Ministry of Fisheries. In these fisheries, collection of catch and effort data has been underway since the resumption of the fisheries in 1991. Initially, catch and effort data were collected only sporadically, owing to manpower and financial constraints. A systematic collection of fisheries data, involving a complete enumeration of catch and effort statistics, was introduced only in 1996. Thus, the present study is based on the data set from 1996 to 2002.

The collection of fishery-dependent data is undertaken by enumerators dispatched to landing sites by the Ministry of Fisheries. These enumerators fill out logbooks for all boats landing their catch at the fishing harbors. The data entered in the logbooks include, among other things, license number, fishing gear type and number, fishing ground, number of crew, fishing days and catch by species or family. Despite the routine recording of catch and effort data, there has not been a systematic collection of fishery-independent data in these fisheries, owing to the lack of expertise and resources. Moreover, although designed

for recording catches at the species level, the CEDRS comprises of records of catch mostly identified only to family or higher taxonomic levels. Thus, the CEDRS best permits analysis at higher taxonomic levels. Our analysis included eleven taxonomic categories (ten families and one class, representing 71 species), with probabilities of capture greater than 10%. The catch of these categories makes up about 96% of the total catch by weight.

2.3. Standardization of CPUE

CPUE was initially expressed as catch per trip ($\text{kg}\cdot\text{trip}^{-1}$). Differences in fishing power, gear type, crew number etc. among vessels may however create variations in CPUE unrelated to fish abundance. Therefore, it was essential to standardize CPUE to minimize bias and to be able to make valid comparisons across the entire fishery. For this purpose, the effects of various possible measures of effort on CPUE were assessed in a generalized linear model (GLM) using SAS software (SAS Institute Inc. 1999). In this model, a number of possible measures of effort, including crew size per trip, number of days per trip, mandays, and number of hooks or gillnets per trip, were related to the response variable CPUE. Even though mandays is simply a product of crew size and number of days at sea, we anticipated that the use of mandays as a single predictor of CPUE, as opposed to crewsize and number of days taken separately, might give rise to a more parsimonious model.

Given the heterogeneity in fishing gear and craft within the artisanal fisheries, the model was run separately for six boat–gear combinations.

$$\log_{10}(\text{CPUE}_i) = \beta_0 + \beta_1 \log_{10}(f_{1i}) \dots + \beta_n \log_{10}(f_{ni}) + \varepsilon_i$$

where CPUE_i is the observed CPUE in the i^{th} fishing trip; f_{ni} is the effort level of the i^{th} fishing trip in terms of the n^{th} effort measure; β_0 is the intercept, $\beta_1 - \beta_n$ are slopes to be estimated for each of the boat–gear combinations and ε_i is a random error term. The use of log-transformed catch and effort data allows us to achieve normality and homoscedasticity in the error distribution, while at the same time accounting for the multiplicative nature of the relationship between CPUE and effort measures.

To avoid over-parameterization and arrive at a more parsimonious model, we needed to select only those predictors that add a considerable amount of explained variance. For this purpose, we compared the percentage of explained variance in the full model (i.e. using all

the predictors) with the percentages explained in reduced models (i.e. using only some of the predictors). Since a single effort measure was found to account for most of the explained variability in the full model for all boat–gear combinations, the remaining factors were excluded as predictors of CPUE. The CPUE could then be standardized for the selected predictors using the relationship:

$$CPUE_i^s = CPUE_i \cdot (\bar{f}/f_i)^\beta$$

where $CPUE_i^s$ is the standardized CPUE for the i^{th} fishing trip, \bar{f} is the mean value for the selected effort measure. β is the coefficient for the selected effort measure from the GLM, and f_i/\bar{f} represents a standardized trip.

2.4. Trends in CPUE, catch and effort

Using standardized CPUEs, we examined developments in the artisanal fisheries by analyzing trends in mean total annual CPUE as well as in CPUE of each of the different taxonomic categories using the GLM procedure. In this procedure, we assumed that the relationship between CPUE and year might be curvilinear (quadratic) and thus we chose a model with a linear and a quadratic term as independent variables, forming a second-order polynomial. In this step, we run a joint model for the entire fishery by taking boat–gear combination as a covariable in a single GLM. The model was given as:

$$CPUE_{ij}^s = \mu + \alpha_j + \beta_1 \cdot (\text{year}_j - \overline{\text{year}}) + \beta_2 \cdot (\text{year}_j - \overline{\text{year}})^2 + \varepsilon_{ij}$$

where $CPUE_{ij}^s$ is the mean annual standardized CPUE for the i^{th} boat–gear combination (i varies from 1 to 6) in the j^{th} year; μ is the baseline mean; α_i is the adjustment to the mean for the i^{th} boat–gear combination; β_1 and β_2 are slopes for year and year-squared, $\overline{\text{year}}$ is the mean value for year (thus, the independent variable year was orthogonalized in the analysis) and ε_{ij} is a random error term.

Subsequently, we examined developments in the artisanal fisheries by analyzing trends in total annual catch and effort as well as in annual catch of each of the different categories. The trends in total catch and effort were also analyzed for each of the two types of boats separately. Furthermore, we assessed trends in the pelagic–demersal ratio (P/D), an index

that is can be used a proxy measures for the differential impacts of fishing on pelagics and demersals. For this purpose, the fishes in the catch were divided into pelagics and demersals, with mackerels and tunas (Scombridae), barracudas (Sphyraenidae), jacks (Carangidae), cobias (Rachycentridae), and sharks (Elasmobranchii) making up the pelagics, while snappers (Lutjanidae), groupers (Serranidae), emperors (Lethrinidae) forming the demersals (Froese and Pauly, 2006).

2.5. Temporal changes in gear–boat composition

Trends in CPUE of the different taxonomic categories (and hence changes in catch composition) could be due to shifts in gear and/or boat combination rather than to changes in fish community structure. Therefore, we explored if there were any changes in the boat and/or gear composition over the years underlying changes in catch composition.

2.6. Spatial patterns in effort allocation

Since trends in CPUE of the different categories (and hence changes in catch composition) might also be associated with changes in spatial allocation of effort, we explored if there were any such changes over the years investigated. For that purpose, we divided the fishing area using grids of different cell sizes. We compared grids of 10, 20, 50, 100, and 200 km-long cells, and selected a grid with the highest spatial resolution that maintains an approximately normal distribution of standardized CPUE in each cell over the years. Once an optimal grid was selected, we analyzed temporal and spatial variations in the allocation of effort (standardized trips) using GLM, with location (grid cell) and year as the main factors and year \times location as interaction term.

2.7. Temporal effort dynamics

Temporal dynamics in fishing effort were examined by analyzing the difference between actual and potential effort over the years. We used the number of trips per given time interval as a measure of temporal effort allocation. The number of trips within a 1-day, 2-day, 1-week, 2-week, 1-month, or a 2-month time intervals were analyzed to select the shortest time interval possible that would give rise to an approximately normal error distribution around the mean number of trips per time interval.

The potential for an instantaneous increase in fishing effort was examined by comparing the number of active fishing vessels with the total number of operational vessels within a given time interval. Vessels that carried out at least a single fishing operation within the 3-month period preceding a given time interval were counted as operational fishing vessels for that time interval. Of the operational vessels, the ones that carried out at least a single fishing operation within a given time interval were counted as active vessels, else they were considered as latent fishing effort.

3. Results

3.1. Standardization of CPUE

In the full model for the standardization of CPUE, the percentages of explained variance for the different gear–boat combinations ranged from 11 to 47% of the total variance. The percentages of variance explained by individual factors add up to much more than the total explained in the full model, suggesting a high degree of multi-collinearity between these factors. Crew size alone accounted for 10 to 44% of the total variance in CPUE for the different gear–boat combinations (Table 3), making it the most important predictor of CPUE. Mandays was the second most important predictor, explaining 9–40% of the total. Such a small difference in the percentage of explained variance between the full model and either of the reduced models, using crew size or mandays alone, indicates that the remaining factors were far less important predictors of CPUE. Therefore, for the sake of parsimony, we used only crew size or mandays in the standardization procedure, depending on which one is more important as an effort measure for a given boat–gear combination.

Average crew size and mandays and the respective regression coefficients (β_{crew} and $\beta_{mandays}$) for the different boat–gear combinations are listed in Table 3. In most cases, the coefficients were less than 1, indicating that catch per trip increased with crew size or mandays, but eventually leveling off. In the case of houri–gillnet fisheries, $\beta_{crew} > 1$, indicating that catch per trip increased exponentially as crew size increased. This is unlikely for a relationship between catch and effort, implying that the effect of crew size was confounded by the effects of other factors. In this case, mandays, which is equivalent to crew size corrected for the number of days at sea, was found to be a more plausible predictor of CPUE ($\beta_{mandays} < 1$), with only a slightly lower percentage of explained variance (40 vs. 44 %; Table 3)..

Table 3. Percentages of explained variance in a full model^a (including all possible predictors) and in reduced models (including only crew size or mandays), regression coefficients and geometric means of predictors for the reduced models in the standardization of CPUE for the different boat and gear combinations.

Boat type	Gear type	% variance explained					GM	
		Full Model ^a	Crew	MD	β_{crew}	β_{mandays}	Crew	MD
Houri	Gillnet	47	44	40	1.47	0.64	5.0	22.1
	Hook and line	32	30	28	0.81	0.43	5.5	37.2
	Mixed gear	26	12	26	0.64	0.56	6.0	44.6
Sambuck	Gillnet	20	10	20	0.65	0.47	6.7	47.1
	Hook and line	11	10	9	0.50	0.26	6.1	46.0
	Mixed gear	18	17	12	0.43	0.30	7.6	63.6

^a Full model: $\log_{10}(CPUE_i) = \beta_0 + \beta_1 \log_{10}(f_{it}) + \dots + \beta_n \log_{10}(f_{in}) + \varepsilon_i$; MD, Mandays; GM, Geometric mean

Table 4. Geometric mean (GM) of standardized CPUE (kg·trip⁻¹), number of trips (n), standard deviation of the log₁₀-transformed standardized CPUE (SD), and confidence interval factor (F)^a for the different boat and gear combinations.

Boat type	Gear type	Geometric mean (GM)	Number of trips (n)	Standard deviation (SD)	Confidence interval factor (F)
Houri	Gillnet	301	988	0.46	1.07
	Hook and line	453	2017	0.31	1.03
	Mixed gear	509	903	0.32	1.05
	Overall	420	3908	0.36	1.03
Sambuck	Gillnet	575	294	0.37	1.10
	Hook and line	580	1997	0.28	1.03
	Mixed gear	705	487	0.26	1.06
	Overall	600	2778	0.29	1.03

^a F is calculated as $10^{t_{n-1} \cdot (SD / \sqrt{n})}$, where t_{n-1} is the value from the Student's t-distribution. Confidence limits are then calculated as $GM^{\pm F}$.

Geometric mean (GM) of the standardized CPUE was 600 kg·trip⁻¹ for the sambuck fisheries and 420 kg·trip⁻¹ for the houri fisheries across all gears (Table 4). In both fisheries, the fishing trips combining both gillnet and hook and line showed the highest mean CPUE (509 and 705 kg·trip⁻¹ for houris and sambucks respectively), while those employing only

gillnets showed the lowest CPUE (301 and 575 kg·trip⁻¹ for houris and sambucks respectively). Gillnets showed the highest variability in CPUE in both fisheries; the confidence interval factor, F, which is a measure of variability around the GM, was higher for gillnet than for hook and line fisheries (Table 4).

3.2. Trends in CPUE, catch and effort

Although the overall CPUE did not show a significant trend over the years investigated, trends in CPUE varied among the different categories (Table 5, Fig. 2). Whereas the CPUEs for sea catfishes, jacks, grunts, tunas and barracudas showed a significant positive trend, the CPUEs for snappers, emperors and sharks exhibited a significant negative trend. The trend in CPUE was most pronounced for snappers, the most abundant family in the catches. The trend for snappers and emperors were (second-order) polynomial and quadratic, respectively, indicating that the rate of decline was not constant over the years. The coefficient of the quadratic term was negative for snappers, indicating that the rate of decline in their CPUE was higher in the later years. By contrast, the coefficient of the quadratic term was positive for emperors, indicating a lower rate of decline in CPUE in the later years. The CPUE for sharks showed a negative linear trend.

Total annual catch showed a significant linearly increasing trend with an annual rate of increase of 98.4 tonnes·year⁻¹ (Table 6). The highest annual catch of ca. 1000 tonnes was attained in 2000. The total annual catch for houris showed a steady increase of approximately 100 tonnes·year⁻¹ (except in 1998 – 1999), from ca. 200 t in 1996 to ca. 600 t in 2001 (Fig. 3). The total annual catch for sambucks, on the other hand, showed a rapid increase initially, from ca. 200 tonnes in 1996 to ca. 550 tonnes in 1999, but declined rapidly afterwards, dropping to just over 300 tonnes in 2001. Total annual effort, which was expressed as standardized trips per year, also showed a significant linear increase of 112 trips·year⁻¹. The rate of increase in effort was similar to the rate of increase in total catch over the years investigated, resulting in an almost stable CPUE of ca. 419.8 kg·trip⁻¹ for houris and 599.6 kg·trip⁻¹ for sambucks (Fig. 2).

Table 5. Trends in mean annual CPUE of specific taxonomic categories of fish and in mean total annual CPUE (kg·trip⁻¹) from 1996 to 2002, showing the best model fit (95% confidence level), indicated as Lin, linear; Quad, quadratic; Pol, polynomial; NS, non-significant. Also shown are Mean CPUE over the years; CV, coefficient of variation of the residuals; β_1 and β_2 , slopes of the linear and quadratic components of trends; β_{last} , change in mean CPUE from 2001 to 2002; R^2 , percentage of explained variance. Only statistically significant terms are shown.

Category	Model	Mean	CV(%)	β_1	β_2	β_{last}	$R^2(\%)$
Ariidae, sea catfishes	Lin	23.9	21	6.2		6.2	89
Carangidae, jacks	Lin	37.7	7	9.1		9.1	98
Elasmobranchii, sharks	Lin	24.0	19	-3.7		-3.7	79
Haemulidae, grunts	Lin	14.5	21	3.1		3.1	85
Lethrinidae, emperors	Quad	39.4	10		1.1	5.6	63
Lutjanidae, snappers	Poly	103.9	9	-7.5	-3.4	-24.5	86
Rachycentridae, cobias	Poly	10.6	12	0.6	0.1	0.9	57
Scombridae, mackerels	NS	139.7	10				
Scombridae, tunas	Poly	45.3	34	8.2	3.5	25.7	86
Serranidae, groupers	NS	59.4	12				
Sphyraenidae, barracudas	Lin	25.1	13	3.8		3.8	87
TOTAL	NS	514.6	10				

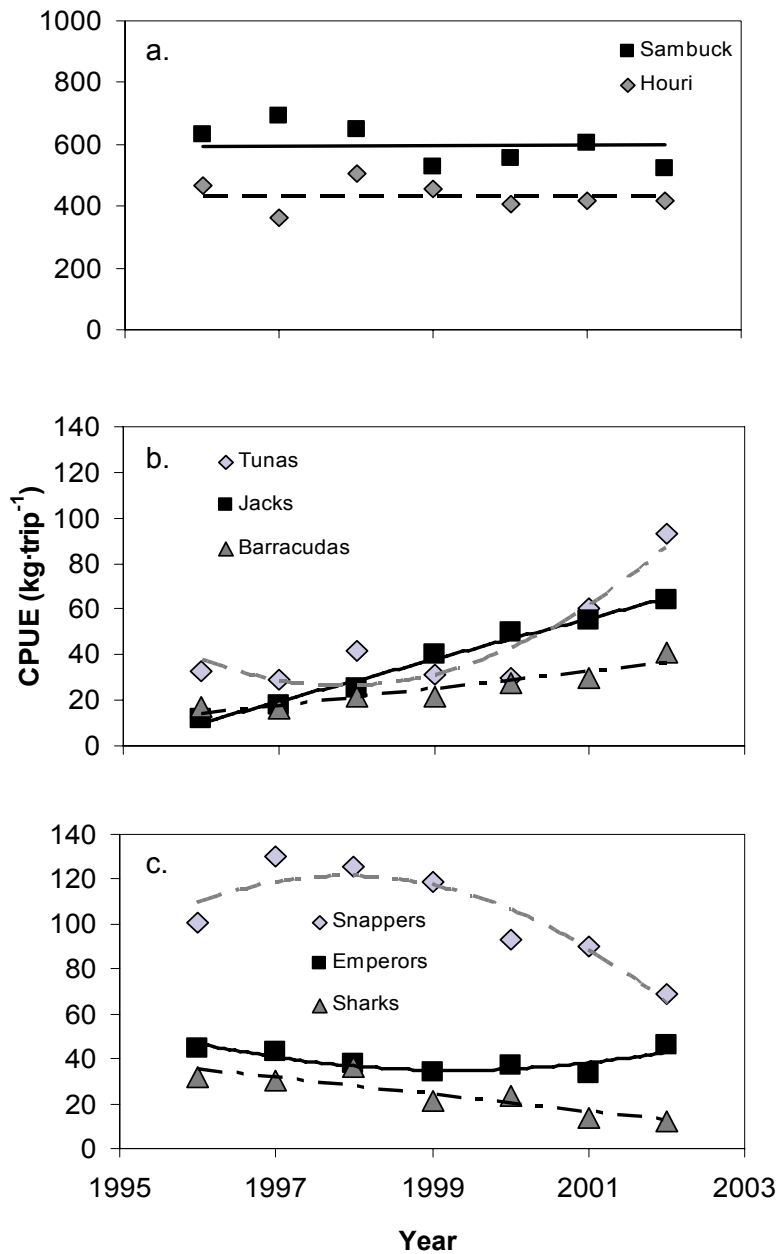

Figure 2. Trends in mean total annual CPUE (kg·standardized trip⁻¹) for houri and sambuck fisheries (a) and in mean annual CPUE of specific categories of fish (b) and (c). The mean of the time-series is shown with a horizontal line if trend is not significant.

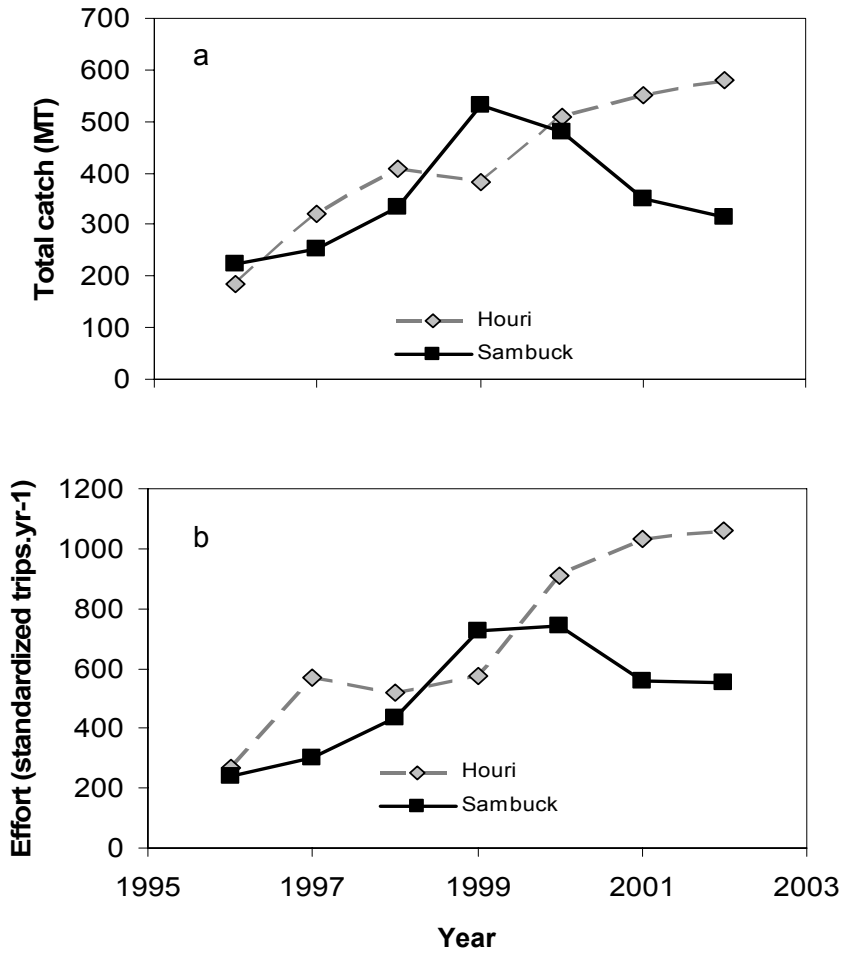

Figure 3. Developments in total annual catch (tonnes·year⁻¹) (a) and effort (standardized trips·year⁻¹) (b) for houri and sambuck fisheries.

Although the total annual catch showed a positive trend over the years, the trends in annual catch varied among the different fish categories (Table 6). Whereas annual catches of sea catfishes, jacks, grunts, emperors, cobias, and barracudas exhibited positive linear trends, the annual catches of snappers and mackerels showed quadratic and (second-order) polynomial trends with negative quadratic term (β_2), indicating an initial increase and a subsequent decrease in their total annual catches. The annual catches of the remaining categories however did not show significant trends.

Table 6. Trends in annual catch of specific categories of fish and in total annual catch (tonnes) and effort (standardized trips) from 1996 to 2002, showing the best model fit (95% confidence level), indicated as Lin, linear; Quad, quadratic; Pol, polynomial; NS, non-significant. Also shown are mean annual catch over the years; CV, coefficient of variation of the residuals; β_1 and β_2 , slopes of the linear and quadratic components of the trends; β_{last} , change in mean catch/effort from 2001 to 2002; R^2 , percentage of explained variance. Only statistically significant terms are shown.

Category	Model	Mean	CV(%)	β_1	β_2	β_{Last}	$R^2(\%)$
Ariidae, sea catfishes	Lin	8.3	62	4.6		4.6	73
Carangidae, jacks	Lin	67.4	45	33.4		33.4	81
Elasmobranchii, sharks	NS	7.9	33			NS	NS
Haemulidae, grunts	Lin	6.2	37	3.1		3.1	87
Lethrinidae, emperors	Lin	86.0	9	10.5		10.5	85
Lutjanidae, snappers	Quad	225.2	5		-21.9	-87.6	94
Rachycentridae, cobias	Lin	3.1	24	1.0		1.0	86
Scombridae, mackerels	Poly	154.0	10	18.5	-10.7	-24.3	84
Scombridae, tunas	Poly	39.1	10	8.3	1.7	17	71
Serranidae, groupers	NS	108.9	29				
Sphyraenidae, barracudas	Lin	33.0	22	11.0		11	88
Total catch	Lin	739.1	17	98.4		98.4	72
Total Effort (std. trips)	Lin	1124	12	112		112	78

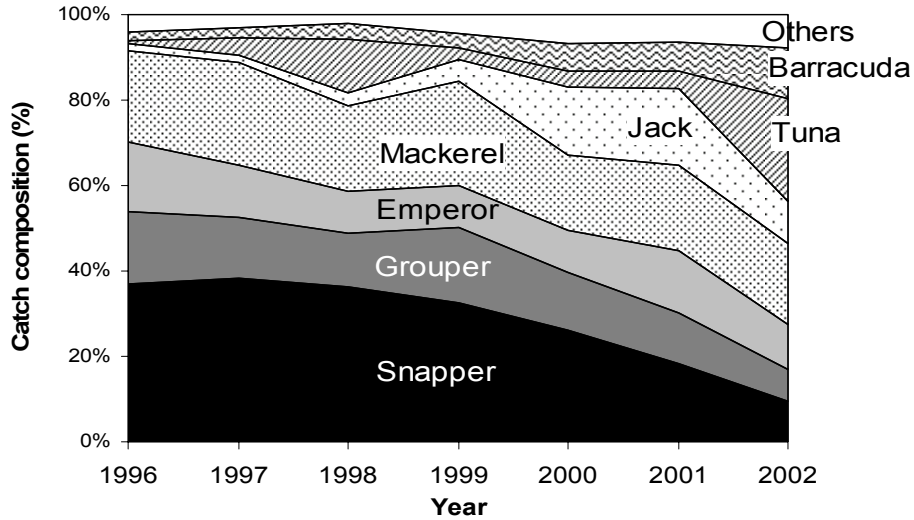

Figure 4. Changes in the percentage composition of the major fish categories in the catch.

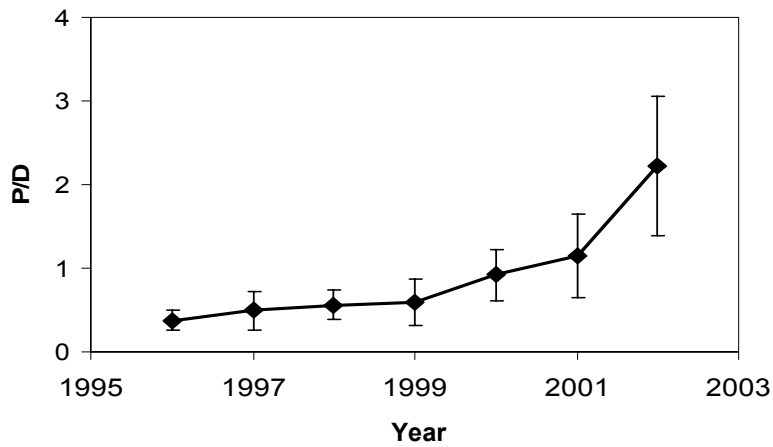

Figure 5. Changes in pelagic–demersal ratio (P/D) in the artisanal catches over the years, 1996 to 2002. Errors bars indicate 95% confidence limits.

The varying trends in the catches of the different taxonomic categories resulted in a shift in species composition of the catches over the years. The contribution to the total catch of the higher-value reef fishes such as snappers, groupers and emperors declined from ca. 70% in 1996 to less than 30% in 2002, whereas the proportion of pelagic fishes such as tunas,

barracudas and jacks increased from less than 5% to more than 45% (Fig. 4). The shifts in catch composition in these fisheries were also apparent from the increase in the pelagic–demersal ratio (P/D) ratio of the catches over the years (Fig. 5).

3.3. Temporal changes in gear–boat composition

Changes in catch composition were accompanied by changes in the proportion of the two types of boats used in the artisanal fisheries, with houris becoming increasingly more important over the years (Fig. 3 and 6). However, there were no significant changes in the gear composition used that could possibly explain the shifts in catch composition over the years (Fig. 6). Moreover, there were no apparent changes in the technical specifications of the gear used, as the mesh size of gillnets or size of hooks used in these fisheries remained unchanged over the period investigated (Mengisteab Teklu, Ministry of Fisheries, personal communication).

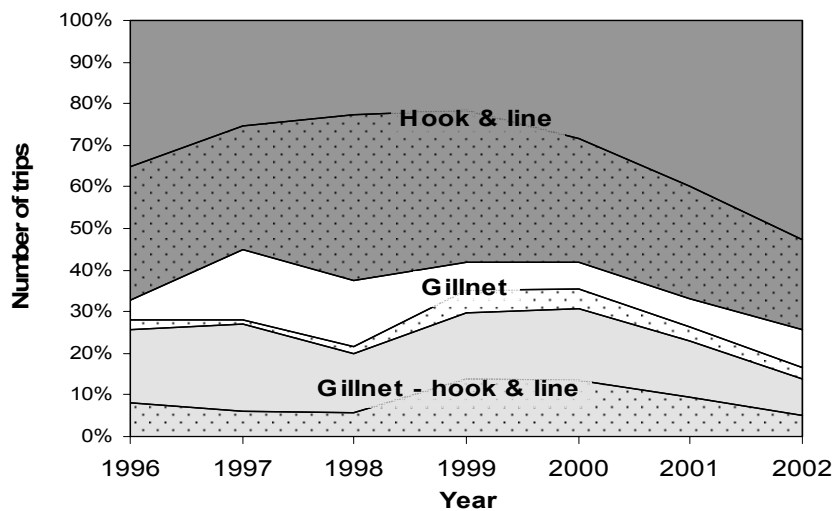

Figure 6. The percentage of trips using hook and line, gillnets or a combination of the two gears from 1996 to 2002. Stippled areas represent trips by sambuck, non-stippled areas are trips by houri.

3.4. Spatial allocation of fishing effort and trends in CPUE

A grid of 50 by 50 km cells was found to provide the highest spatial resolution while maintaining an approximately normal distribution of CPUE within each of the cells (results

not shown). The annual level of effort showed a positive trend for most fishing areas (Fig. 7). In the ANOVA model, the level of effort varied significantly among locations and over the years (Table 7). Accordingly, the effect of the year \times location interaction term was not significant, indicating that the trends in effort did not vary across fishing grounds. This suggests that there were no changes in the spatial allocation of fishing effort over the years at a 50x50 km scale.

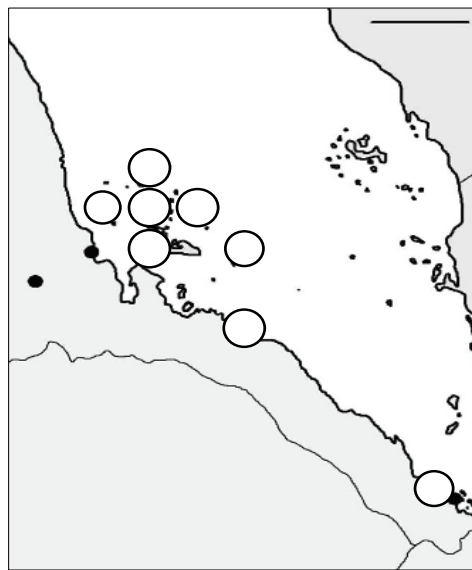

Figure 7. Trends in the spatial effort allocation across a 50x50 km grid. Area of circles represents the magnitude of significant positive linear trends. No significant negative linear trends were found. Scale bar represents 100 km.

Table 7. Trends in the spatial allocation of effort derived using a general linear model with year and location (grid cell) as the main factors, and year \times location as interaction term; df, degrees of freedom.

Source	Sum of squares	d.f.	Mean square error	F-statistic	P-value
Year	3900	1	3900	49.76	<0.0001
Location	4046	27	150	1.91	0.01
Year \times location	1600	27	59	0.76	0.792
Error	8778	112	78		

3.5. Latent fishing effort

For the determination of latent fishing potential, we selected a two-week period as the shortest time interval possible that could give rise to a normal distribution of the number of trips per time interval over the years (results not shown). We found that for the period 1997–2000, during which fishing activity increased gradually (Fig. 3), only around 24% of the licensed vessels were active (Fig. 8). The proportion of active vessels remained fairly stable throughout the rest of the period investigated, indicating that the increase in fishing effort over the years was mainly associated with an increase in the number of fishing trips rather than with an increase in the number of boats.

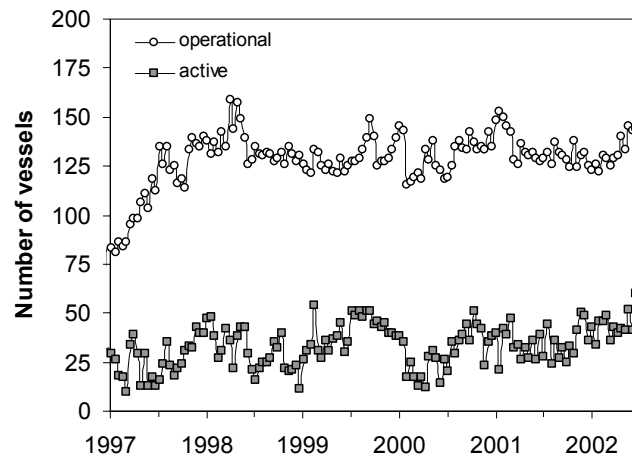

Figure 8. Temporal effort dynamics in terms of number of active fishing vessels vs. number of licensed operational fishing vessels in consecutive two-week intervals.

4. Discussion

Elucidating trends in catch rates is important to monitor the state of fish stocks and fisheries and guide management action. In the analysis of trends in catch rates for the artisanal fisheries of Eritrea, it was essential to standardize CPUE to allow valid comparisons of catch rates over time or across fishing grounds (Grant et al., 2004; Bishop, 2006). In the standardization procedure, only crew size or mandays was selected as a predictor of CPUE (depending on the fishery type), mainly because one or the other alone accounted for most of the explained variance in the full model. Although the remaining factors accounted for a

significant amount of explained variability, they were excluded as predictors of CPUE in order to improve parsimony. The use of the remaining factors alongside crew and mandays would otherwise result in a large number of parameters, impairing our ability to characterize fishing operations in a simple effort-related term (Battaile, and Quinn, 2004). Besides, in the standardization of catch rates, minimizing bias by adjusting for the most plausible predictors is considered more important than maximizing explained variability (Bishop, 2006). In this regard, crew size and mandays, being direct measures of human input, are apparently the best predictors of CPUE for fisheries that are characteristically labor-intensive (Dalzell, 1996).

Our analysis of standardized catch and effort data for the artisanal fisheries revealed a steady increase in annual effort and a proportional increase in total annual catches (Fig. 3). This resulted in overall CPUE remaining constant over the period investigated, implying that the existing exploitation patterns were sustainable (Pauly et al., 1998). However, through analysis at a lower taxonomic level, we showed that the CPUE for snappers, and sharks declined, while the CPUE for jacks, tunas and barracudas increased (Table, 5), resulting in clear shifts in catch composition over the years (Fig. 5). The shifts in catch composition may be interpreted as reflecting a shift in the underlying fish community structure. The varying trends in CPUE may also reflect varying levels of fishing pressure the different categories were subjected to, with the decline in the CPUE of snappers, emperors and sharks suggesting a higher concentration of fishing effort on these fishes.

Whether trends in CPUE in the artisanal fisheries reflect proportional changes in fish abundance could not be proven directly, because fishery-independent data were not available. Instead, we could use catch and effort data to evaluate the state of fish stocks assuming that changes in CPUE (and hence changes in catch composition) reflect changes in fish community structure (Caddy et al., 1998; Myers and Worm, 2003). Indeed, where changes in CPUE occur, they may, but not necessarily, reflect changes in fish abundance. It is possible that changes in CPUE in the artisanal fisheries may simply be due to changes in species targeting from demersals toward pelagics. Such changes in species targeting could occur due, among other things, to improvements in technology, craftsmanship etc. for capture of pelagics. Our analysis however indicated that there were no significant changes in gear and boat type used for the capture of pelagics; nor were there any signs of fishing trips being shorter over the years for these fishes (a possible sign of improved craftsmanship; results not shown). Therefore, it is unlikely that improvements in the capture of pelagics could have offset the strong market incentive for targeting demersal fishes and

trigger shifts toward the lower-value pelagics, suggesting that changes in CPUE could indeed reflect changes in fish abundance. Yet, there may still be some socio-economic factors, such as changes in the relative market values of the various fish species or costs of fishing, that could have caused shifts in species targeting. We are investigating the possible effects of such factors in a subsequent work.

Meanwhile, we found no changes in the spatial allocation of fishing effort at a 50x50 km scale or in gear composition, making it unlikely that the shifts in catch composition were caused by changes in fishing strategies (Fig. 7; Table 7). Therefore, if shifts in spatial allocation of effort did ever take place, they could only have occurred at smaller spatial scales. Generally, fishers could make spatial reallocation of fishing effort in recognition of small-scale ecological heterogeneity within fishing areas, where coral reefs and open water, and their associated ichthyofauna are found interspersed. The spatial resolution of the existing data recording system is however too crude to discern fine spatial changes.

That having been said, the decline in CPUE of some of the fish categories nonetheless appears too premature for a fishery with only a short history of development to be interpreted as reflecting a proportional decline in fish abundance. Rather, the decline in CPUE could simply be due to “hyperdepletion”, i.e. a steep decline in CPUE as the most vulnerable subset of the population is depleted, creating an appearance that stock size has declined much more than it actually has (Hilborn and Walters, 1992; Myers and Worm, 2003; Lorenzen et al., 2006). Yet, the trends in CPUE of the demersal fishes could still represent proportional changes in fish abundance even at the early stages of fisheries, given that the stocks of reef-associated demersal fishes are highly vulnerable to fishing, owing to their slow growth, low fecundity and lower intrinsic rate of population increase (Appeldoorn et al., 1992; Dulvy et al., 2004b). This is more so given the highly selective nature of species targeting strategies in the artisanal fisheries. Besides, our estimates of the existing levels of fishing intensity over the years were rather conservative, because they were based only on official statistics, excluding the supposedly large amounts of unreported catches taken to Yemen (Moussalli and Haile, 2001). Accordingly, changes in CPUE could indeed represent substantial biomass changes, not least the risk of localized depletion (Walters, 2003; Lorenzen et al., 2006).

Generally, the overall trend we revealed for the artisanal fisheries, albeit based on short time-series data, is reminiscent of the gradual transition in global catches from higher-value demersals to lower-value pelagics associated with expansion of fisheries (Grainger and

Garcia, 1996), potentially leading to fishing down the food webs (Pauly et al., 1998). This contrasts with the “fishing through the food webs”, a phenomenon which represents the serial addition of new species into the catch with the expansion of fisheries (Essington et al., 2006). Nevertheless, in contrast to the downward shifts in mean trophic level of catches characteristic of the “fishing down the food webs” phenomenon, the shifts in species composition in the artisanal fisheries took place only across predatory species, particularly from snappers and groupers toward tunas and barracudas. Yet, as the fisheries continue to expand, a “fishing down the food webs” phenomenon is expected to occur, as exploitation of fisheries resources often starts by focusing on top predators, but gradually shifting toward lower trophic level species (Pauly et al., 1998; Jennings et al., 1999). It has been widely documented that expansion of fisheries leads to the disappearance of higher-value species such as groupers and snappers, eventually resulting in the predominance of “trash fish”, i.e. small species and the juveniles of larger, commercial species, in the catches (Christensen and Pauly, 2001)

The relatively low level of effort in the artisanal fisheries has been attributed to unfavorable market conditions prevailing over most of the period investigated (mainly low fish prices and high fuel costs). Our results showed that only less than 25% of the registered fishing fleet were active at any given moment over the years investigated (Fig. 8), leaving the rest of the fishing fleet either lying idle or being used for other commercial purposes, such as transportation of people and goods (personal observation). The latter represents a sizeable latent fishing potential that could be set in motion at any moment pending an improvement in market conditions. This could lead to a surge in fishing activity, with potentially more serious ecological consequences, particularly for the stocks of predatory fishes, which had already shown a sign of decline even when the fishery was operating only at a quarter its capacity.

In conclusion, the concentration of fishing effort on selected species – for their market value or ease of capture – and/or specific areas could have adverse consequences for the sustainability of reef fisheries. Therefore, the continued strong economic incentive for the artisanal fishers to mainly target reef-associated demersal fishes remains a cause for concern. In order to promote sustainable fisheries, fishing activities should be well dispersed over the whole range of coastal and island reef and open water systems, targeting a diverse array of species (Bundy et al., 2005). In the artisanal fisheries, since gears mainly target specific species of fish, they can also be selectively controlled as a management option to control the capture of vulnerable species (McClanahan and Mangi, 2004). Finally,

to be able establish a direct link between changes in CPUE and changes in abundance of reef fish assemblages in the Eritrean Red Sea, we recommend the CEDRS be coupled with a systematic collection of fishery-independent measures of fish abundance.

Acknowledgements

We would like to thank the Research and Statistics Division of the Ministry of Fisheries, Eritrea for providing us with the catch and effort data and for their helpful discussion. We are also grateful to Ir. Paul van Zwieten, Prof. Johan Verreth, Prof. John Videler and two anonymous reviewers, whose comments on the initial manuscript greatly improved the quality of this work. This study was supported by the Netherlands Organization for International Cooperation in Higher Education (Nuffic) as part of the MBF–UoA–MHO project.

References

- Antoine, L., Blanchard, F., Boucher, J., Massé, J., Morizur, Y., Araia, T., Mahmoud, S., Wolday, S., 1998. Assessment and follow-up of the potential of fisheries resources in Eritrea. Fisheries resources assessment project MOF–IFREMER–CFD, 24 pp+addenda.
- Appeldoorn, R., Beets, J., Bohnsack, J., Bolden, S., Matos, D., Meyers, S., Rosario, A., Sadovy, Y., Tobia, W., 1992. Shallow water reef fish stock assessment for the U.S. Caribbean. NOAA Tech. Memo. NMFS–SEFSC–304, 70 pp.
- Aubray, R., 1975. The fisheries of Ethiopia. An economic study. FAO, Rome, 23 pp.
- Battaille, B.C., Quinn, T.J., 2004. Catch per unit effort standardization of the eastern Bering Sea walleye pollock (*Theragra chalcogramma*) fleet. Fish. Res. 70, 161–177.
- Bishop, J., 2006. Standardizing fishery-dependent catch and effort data in complex fisheries with technology change. Rev. Fish. Biol. Fish. 16, 21–38.
- Bundy, A., Pauly, D., 2001. Selective harvesting by small-scale fisheries: ecosystem analysis of San Miguel Bay, Philippines. Fish. Res. 53, 263–281.
- Bundy, A., Fanning, P., Zwanenburg, C.T., 2005. Balancing exploitation and conservation of the eastern Scotian Shelf ecosystem: application of a 4D ecosystem exploitation index. ICES J. Mar. Sci. 62: 503–510.
- Caddy, J. F., Csirke, J., Garcia, S. M., Grainer, R. J. R., 1998. How pervasive is “Fishing Down Marine Food Webs”? Science 282, 183.
- Christensen, V., 1996. Virtual population reality. Rev. Fish. Biol. Fish. 6, 243–247.

- Christensen, V., Pauly, D., 2001. Coral reef and other tropical fisheries. In: Steele, J.H., Thorpe, S.A., Turekian, K.K. (Eds.), *Encyclopedia of Ocean Sciences*. Academic Press, San Diego, pp 534–538.
- Dalzell, P., 1996. Catch rates, selectivity and yields of reef fishing. In: Polunin, N.V.C., Roberts, C.M. (Eds.), *Reef Fisheries*. Chapman and Hall, London, pp 193–218.
- Dulvy, N.K., Freckleton, R.P., Polunin, N.V.C., 2004. Coral reef cascades and the indirect effects of predator removal by exploitation. *Ecology Letters* 7, 410–416.
- Dulvy, N.K., Polunin, N.V.C., Mill, A.C., Graham, N.A.J., 2004. Size structural change in lightly exploited coral reef fish communities: evidence for weak indirect effects. *Can. J. Fish. Aquat. Sci.* 61, 466–475.
- Essington, T.E., Beaudreau, A.H., Wiedenmann, J., 2006. Fishing through marine food webs. *Proc. Nat. Acad. Sci.* 103, 3171–3175.
- Froese, R., Pauly, D. (Eds.), 2006. *FishBase*. World Wide Web electronic publication. www.fishbase.org, version (07/2006).
- Gaudet, J.L., 1981. Report on mission to Ethiopia. Fisheries Policy and Planning Service files. Rome, FAO (mimeo).
- Ghebremichael, A. and Haile. S., 2006. *Commercial fishes of the Eritrean Red Sea*. Apex Publishing Ltd., Essex, England, 266 pp.
- Grainger, R.J.R., Garcia, S.M., 1996. *Chronicles of marine fishery landings (1950–1994): Trend analysis and fisheries potential*. FAO Fisheries Technical Paper No. 359. FAO, Rome, 51 pp.
- Grant, C.G., Schwartz, Y., Weisberg, S., Schupp, D.H., 2004. Trends in abundance and mean size of fish captured in gill nets from Minnesota Lakes, 1983–1997. *N. Am. J. Fish. Manage.* 24: 417–428.
- Grofit, E., 1971. *The Red Sea fisheries of Ethiopia*. Centre for Agricultural Cooperation with Developing Countries, Ministry of Agriculture, Isreal, 82 pp.
- Guidicelli, M., 1984. *The Ethiopian fisheries: situation, development needs and opportunities*. Report prepared for the Fishery Planning and Development Project. Field Document (FI/DP/ETH/82/016). FAO, Rome, 157 pp.
- Habte, I., 2003. Commercial status of twin spot snapper (*Lutjanus bohar*) and Gold band job fish (*Pristipomoides filamentosus*) in fisheries of Eritrea. In: Palomares, M.L.D., Samb, B., Diouf, T., Vakily, J.M., Pauly, D. (Eds.), *Fish Biodiversity: Local Studies as basis for Global Inferences*. ACP–EU Fisheries Research Report, 14. Brussels, pp 62–66.
- Hartmann, S., 1998. *Artisanal landings by motorized vessels in Massawa in recent times; 1994–1997*. Ministry of Fisheries, Massawa, Eritrea. 41pp+addenda.
- Hilborn, R., Walters, C.J., 1992. *Quantitative fisheries stock assessment – choice dynamics and uncertainty*. Chapman & Hall, New York, 570 pp.

- Jennings, S., Lock, J.M., 1996. Population and ecosystem effects of reef fishing. In: Polunin, N.V.C., Roberts, C.M. (Eds.), Reef Fisheries. Chapman and Hall, London, pp 193–218.
- Jennings, S., Greenstreet, S.P.R., Reynolds, J.D., 1999. Structural change in an exploited fish community: a consequence of differential fishing effects on species with contrasting life histories. *Journal of Animal Ecology* 68, 617–627.
- Kelleher, K., 2005. Discards in the World's Marine Fisheries. FAO Fisheries Technical Paper No. 470. FAO, Rome, 51 pp.
- King, M., 1995. Fisheries Biology, Assessment and Management. Fishing News Books, Blackwell, Oxford, 341 pp.
- Larkin, P.A., 1996. Concepts and issues in marine ecosystem management. *Rev. Fish. Biol. Fish.* 6, 139–164.
- Lorenzen, K., Almeida, O., Arthur, R., Garaway, C., Khoa, S.N., 2006. Aggregated yield and fishing effort in multispecies fisheries: an empirical analysis. *Can. J. Fish. Aquat. Sci.* 63, 1334–1343.
- Magnusson, K.G., 1995. An overview of the multispecies VPA – theory and applications. *Rev. Fish Biol. Fish.* 5, 195–212.
- McClanahan, T. R., Polunin, N. V. C., Done, T.J., 2002. Ecological states and the resilience of coral reefs. *Conserv. Ecol.* 6, 18.
- McClanahan, T., Mangi, S.C., 2004. Gear based management of a tropical artisanal fishery based on species selectivity and capture size. *Fish. Manag. Ecol.* 11, 51–60.
- Ministry of Fisheries, 2002. Executive Summary of the Ministry of Fisheries Report. Massawa, Eritrea.
- Moussalli, E., Haile, T., 2001. Ex post Evaluation of the Semhar Fisheries Rehabilitation Project ERI/92/001(UNDP) ERI/92/C01 (UNCDF) and Capacity Building for the National Marine Resources Programme ERI/94/001 (UNDP). UNDP, 53 pp.
- Myers, R. A., Worm, B., 2003. Rapid worldwide depletion of predatory fish communities. *Nature* 423, 280–283.
- Pauly, D., Christensen, V., Dalsgaard, J., Froese, R., Torres, F.C., 1998. Fishing down marine food webs. *Science* 279, 860–863.
- Pauly, D., Murphy, G.I. (Eds), 1982, Theory and management of tropical fisheries. ICLARM Conference Proceedings. Cronulla, Australia, 360 pp.
- Parsons, T.R., 1996. The impact of industrial fisheries on the trophic structure of marine ecosystems. In: Polis, G.A. and Winnemiller, K.D. (Eds.), *Marine Foodwebs: Integration of Patterns and Dynamics*. Chapman and Hall, New York, pp. 352–357.
- Reynolds, J.E., Appleton, J., Bellemans, M.S., Bonzon, A., Christy, L.C., 1993. The fisheries of Eritrea, part. 1: Sector review. part. 2: Proposed national fisheries strategy and development program. Terminal Report, FI:FAO/TCP/ERT/2251. FAO, Rome.

- Sadovy, Y.J., 2005. Trouble on the reef: the imperative for managing vulnerable and valuable fisheries. *Fish and Fisheries* 6, 167–185.
- Salih, S.A., 1998. Report on a community-based frame survey. Research and Training Division, Ministry of Fisheries, Eritrea, 29 pp.
- Sanders, A.P.L., Morgan, G.R., 1989. Review of the fisheries resources of the Red Sea and the Gulf of Aden. FAO Fisheries Technical Paper. No. 304. FAO, Rome, 138 pp.
- SAS Institute Inc., 1999. SAS/STAT[®] Users Guide. Version 8. SAS Institute Inc., Cary, N.C.
- Sparre, P., 1991. Introduction to multispecies virtual population analysis. *ICES Mar. Sci. Symp.* 193, 12–21.
- Sparre, P., Venema, S.C., 1998. Introduction to tropical fish stock assessment, Part 1, manual. FAO Fish. Tech. Pap. No. 306.1, Rev. 2. FAO, Rome, 407 pp.
- Vasconcellos, M., Cochrane, K., 2005. Overview of world status of data-limited fisheries: Inferences from landing statistics. In: Kruse, G.H., Gallucci, V.F., Hay, D.E., Perry, R.I., Peterman, R.M., Shirley, T.C., Spencer, P.D., Wilson, B., Woodby, D. (Eds), *Fisheries Assessment in Data-Limited Situations. Proceedings of the 21st Lowell Wakefield fisheries symposium*. Fairbanks, Alaska, pp 1–20.
- Walters, C., 2003. Folly and fantasy in the analysis of spatial catch rate data. *Can. J. Fish. Aquat. Sci.* 60:1433–1436.
- Wilkinson, C. (Ed.), 2002. *Status of Coral Reefs of the World: 2002*. Australian Institute of Marine Science, Townsville, Australia, 363 pp.

CHAPTER 3

Changes in catch composition in the multispecies fisheries of Eritrea in relation to biological and socio-economic factors

Iyob Tschaye^{1,2}, Nikolas K. Michailidis¹ and Leopold A.J. Nagelkerke¹

¹*Aquaculture and Fisheries Group, Wageningen University, Wageningen Institute of Animal Sciences, Marijkeweg 40, 6709 PG Wageningen, the Netherlands.*

²*Department of Marine Sciences, University of Asmara, P.O. Box 1220, Asmara, Eritrea*

Abstract

We examined changes in catch composition in the artisanal fisheries of Eritrea, over the years 1996–2004, in relation to biological and socio-economic factors using multivariate statistical techniques. For this purpose, we corrected catch rates for systematic differences in fishing power among vessels, which could cause non-random variations unrelated to abundance. These variations were quantified and partialled out of the multivariate model by incorporating gear and boat in the model as covariables. In so doing, we removed a considerable amount of variability in catch rate, which could otherwise blur the actual relationship between catch composition and explanatory variables. Ordination of the corrected catch rate data using detrended correspondence analysis (DCA) revealed shifts in catch composition over the years. Our examination of the trends in catch rates of individual species underlying the shifts catch composition showed that these shifts were mainly due to a decrease in the catch rate of snappers (Lutjanidae), groupers (Serranidae) emperors (Lethrinidae) and sharks (Elasmobranchii) and a simultaneous increase in the catch rate of as jacks (Carangidae), tunas (Scombridae) and barracudas (Sphyraenidae). We also showed that trends in multivariate catch composition indices were more pronounced within boat than within gear categories, implying that the shifts in catch composition were more strongly associated with changes in gear composition than with boat. Overall, the socio-economic variables considered in this study accounted for about 19.4% of the changes in catch composition over the years investigated. Our results suggest that while socio-economic changes are likely mechanisms to explain part of the observed changes, the influence of increased fishing pressure cannot be ruled out. The shifts in catch composition could thus be interpreted as partly reflecting a shift in the underlying fish community structure. Nevertheless, a direct statistical linkage between trends in catch rates and possible changes in the underlying fish community structure could not be established, as it requires confrontation of our results with fishery-independent data, which were unfortunately not available for these fisheries.

Keywords: Catch composition, Eritrea, Multispecies fisheries, Multivariate analysis, Red Sea, Socio-economic variables.

1. Introduction

The reef-associated fish resources of Eritrea's Red Sea coast are exploited almost exclusively by artisanal fisheries. The artisanal fisheries of Eritrea were launched into a renewed development in 1991 after a decades-long standstill, which was caused by the country's war for independence (Reynolds et al., 1993; Ghebremichael and Haile, 2006). However, despite its short history of development, shifts in catch composition have been observed in the artisanal fisheries (Tsehaye et al., 2007). In these fisheries, even though total catch rate remained unchanged over the years (Morgan, 2006), analysis of catch and effort data at lower taxonomic level revealed a gradual transition in catches from higher-value demersals to lower-value pelagics (Tsehaye et al., 2007).

The changes in catch composition could not be attributed to changes in spatial allocation of effort or to changes in gear or boat used, making it unlikely that they were caused by changes in fishing strategies (Tsehaye et al., 2007). Thus, these changes may be interpreted as reflecting a decline in fish abundance, particularly considering the vulnerability of the stocks of reef-associated species – owing to their slow growth, low fecundity and lower rate of intrinsic rate of population increase – even to limited exploitation (Dulvy et al., 2004). A decline in fish biomass may also be likely even at such an early stage, given the highly selective nature of species targeting strategies in the artisanal fisheries. Moreover, these results would not be unlikely considering the supposedly large amounts of unreported catches. Anecdotal evidence suggests that large amounts of catch (up to $\frac{3}{4}$ of total annual catch) are taken illegally to Yemen, where fish apparently fetch better prices than in Eritrea (Moussalli and Haile, 2001).

On the other hand, even if fishing was found to cause shifts in catch composition in the artisanal fisheries, the influence of socio-economic factors could not be ruled out. Indeed, these fisheries have largely been affected by changes in socio-economic circumstances, some of which are related to the political situation prevailing over the years (Morgan, 2006). The costs of fuel, for example, have more than doubled over the last decade. There have also been changes in the relative market values of the different kinds of fish as well as in the costs of fishing, which could have prompted changes in species targeting strategies. In addition, the artisanal fishers have been seeking alternative sources of income to supplement their livelihood earnings in the face of growing socio-economic hardships. As a

result, many fishers were drawn into sea cucumber fisheries, which have proved to be more lucrative than finfish fisheries over the past few years.¹

Even though socio-economic factors have been cited as possible causes of changes in fisheries, only few studies have directly examined the effects of these factors on the catches in small-scale artisanal fisheries (van Oostenbrugge et al., 2004; Cinner and McClanahan, 2006). In this study, we investigate the influence of changes in socio-economic circumstances on the changes in catch rate and composition in the artisanal fisheries of Eritrea. For this purpose, we considered several scenarios that could have possibly lead to changes in catch composition in these fisheries.

1. Changes in catch composition were related to changes in the fish community structure caused by overfishing. Although this is a very straightforward assumption, it cannot be tested directly because no fishery-independent data are available to confront our results with.
2. Changes in catch composition were associated with changes in relative market values of the different kinds of fish, or other marine resources, such as sea cucumber or snail nail, inducing shifts in species targeting on the part of the fishers.
3. Changes in catch composition were caused by changes in fishing gear and/or craft, or changes in allocation of effort, whereas the fish community structure fluctuated naturally.
4. Changes in catch composition were merely an artefact caused by inconsistency in the catch recording system. In other words, due to changes in the taxonomic resolution of the data recorded over the years, it appears as if stock sizes have changed. Such changes can in turn be attributed to changes in political and/or economic stability leading to the reduction in the number of people involved in the collection of catch data.
5. Changes in catch composition were due to an increase in the proportion of unreported catches. Given the lower prices of fish in local markets, fishers might prefer to sell their catches (mainly illegally) in neighbouring countries, mainly in Yemen, where market circumstances are better than in Eritrea (FAO, 2002). Just as the first hypothesis, this could not be tested directly as reliable data on illegal catches are obviously hard to come by or reconstruct.

¹ Mahmud and Omer (2003). Available at the Ministry of Fisheries Library, P.O. Box 18, Massawa, Eritrea.

These hypotheses were incorporated into a single conceptual model (Fig 1) to examine, using multivariate analysis, the importance of different socio-economic factors in driving changes in catch composition.

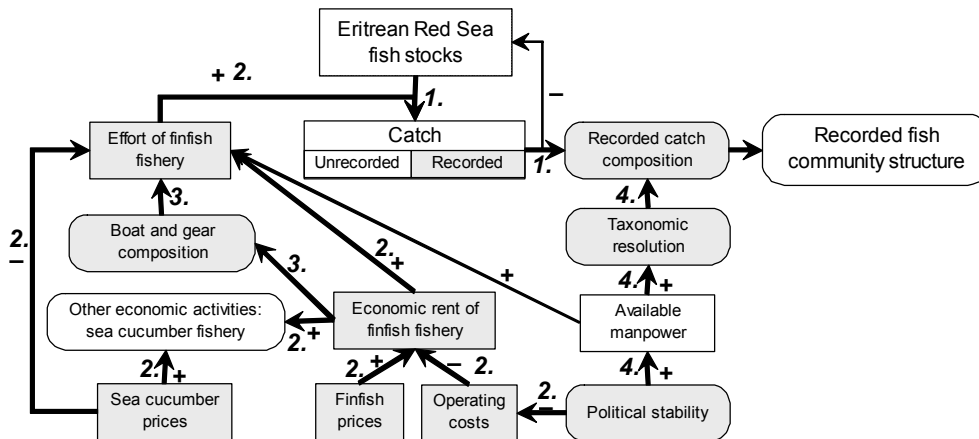

Figure 1. Schematic representation of the conceptual model showing complementary hypotheses that can possibly explain the shifts in catch composition in the artisanal fisheries: (1) changes in the stock composition, (2) changes in the data recording system, (3) changes in effort allocation and (4) unreported catches due to black market.

2. Materials and Methods

2.1. Characteristics of the fisheries

In the artisanal fisheries of Eritrea, most fishing operations are carried out using two types of traditional wooden boats: houris and sambucks, equipped with gillnets, hook and line or a combination of both. Houris are small boats of 4 to 9 m in length equipped with an out-board engine and sambucks are 12 to 17 m boats with an in-board engine. Gillnets are mainly used for the capture of pelagic, and hook and line for demersal fish. The boat's fish hold size and the ice melting rate limit the length of fishing trips to usually not more than 12 days. Given adequate supplies, every boat makes 2–3 fishing trips per month on average.

Most fishing operations in the artisanal fisheries are concentrated around the islands of the Dahlak archipelago, which are scattered between 20 km to 160 km from Eritrea's main port of Massawa (Fig. 2). Whereas houri fishers, owing to the smaller size of their boats, are

mostly restricted to the fishing grounds within 50 to 100 km of the port of Massawa, sambuck fishers often venture into fishing grounds beyond 100 km (Tsehaye et al, 2007). Given its proximity to most of the fishing grounds, and the provision of boat equipment and services therein, most fishers prefer to deliver their catches to the fishing harbours in Massawa.

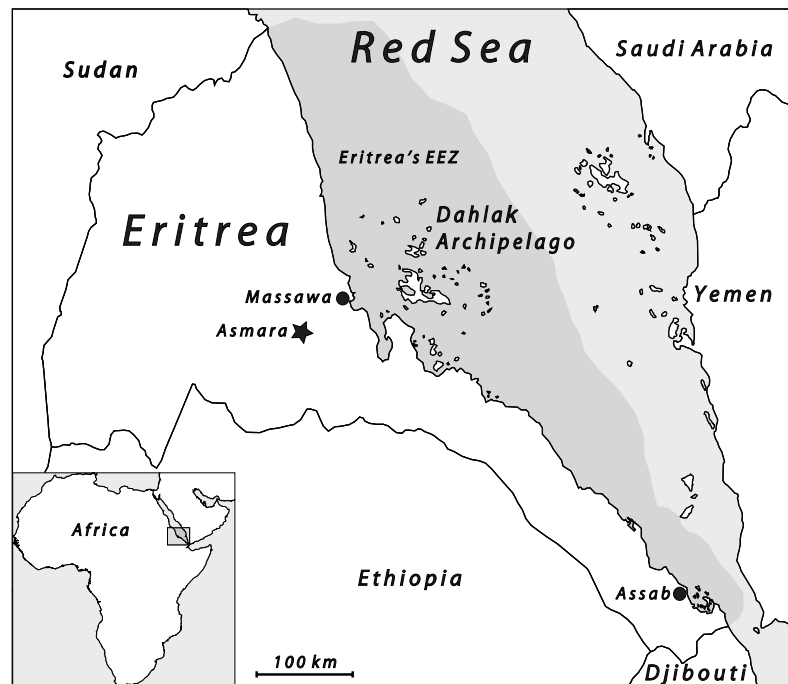

Figure 2. Map of Eritrea showing the distribution of the fishing islands in the EEZ, and the fishing harbours of Massawa and Assab.

The fishing capacity within the artisanal fisheries has been steadily growing since the fisheries were launched in 1991, with the total number of registered boats exceeding 450 in 2002 (Chapter 2, Table 2). Most of the fishing effort has been concentrated on the commercially most important species, including (a) snappers (Lutjanidae), such as Two-spot red snapper (*Lutjanus bohar*), Humpback red snapper (*Lutjanus gibbosus*), and Humphead snapper (*Lutjanus sanguineus*); (b) groupers (Serranidae), such as Brown-spotted grouper (*Epinephelus chlorostigma*), and Malabar grouper (*Epinephelus malabaricus*); (c) emperors (Lethrinidae), such as Longface emperor (*Lethrinus elongatus*),

and Goldband jobfish (*Pristipomoides multidens*); and (d) mackerels and tunas (Scombridae), such as Narrow-barred Spanish mackerel (*Scomberomorus commerson*) and Longtail tuna (*Thunnus tonggol*) (Ghebremichael and Haile, 2006).

2.2. The database

The catch data used in this study were collected by the Research Division of the Ministry of Fisheries, Eritrea as part of the catch and effort data recording system (CEDRS). Fisheries data collection has been underway since the artisanal fisheries were launched in 1991. A systematic collection of fisheries data, involving a complete enumeration of catch and effort statistics, was however introduced only in 1996. Therefore, the present study is based on the database for the period 1996–2004. The database in the CEDRS includes, among other things, license number, fishing gear type and number, fishing ground, number of crew, fishing days and catch by species or family on individual fishing trips. Although designed for recording catches at the species level, the CEDRS mainly consists of records of catch identified only to family level. Thus, the present study is based on analysis at a family level.

We used catch rates of individual fish families for the years 1996-2004 – given as catch weight per standardized trip (Tsehaye et al., 2007) – as response variables in the multivariate analysis. We compiled a data set for explanatory (socio-economic) variables based on official statistics and unpublished Ministry of Fisheries reports. A data set on gross returns was reconstructed using data from the CEDRS on catches and monthly ex-vessel prices of all fish families, i.e. the price paid to the fishers. Data on three other marine products, namely white and black sea cucumbers and snail nail were obtained from the Ministry of Fisheries reports. A data set on running costs was reconstructed from official statistics on the costs of fuel, ice, and other supplies for individual fishing trips. Nominal prices were converted into real prices using the Consumer Price Index (CPI) as a price deflator. CPI is used as a measure of the value of goods in a certain time period relative to their value in a base period (IMF, 2005). In this study, all prices were standardized against values in the year 1996. A list of all the explanatory variables finally considered in the multivariate model is shown in Table 1.

Table 1. List of explanatory variables considered in the multivariate analysis.

Explanatory variable	Description	Source
Trip	Number of trips per year	CEDRS
Boat	Proportion of hours to sambucks per month	CEDRS
Gear type	Proportion of hook and line to gillnet per month	CEDRS
Prices of petrol and diesel	Costs in Eritrean Nakfa on monthly basis	CEDRS
Taxonomic resolution	Expressed as the proportion of catches by weight identified to species level	CEDRS
Political stability	Represented by a dummy variable, with a unit indicating stability and a zero insatiability.	Values of 1 were given for the period 1996–1998; values of 0 were given for the rest.
Prices of sea cucumber	Prices on monthly basis	CEDRS ^{2 3}
Prices of snail nail	Prices on monthly basis	CEDRS
Prices of fish	Prices of the different families on monthly basis in Eritrean Nakfa (Nfa); 1 USD \approx 15 Nfa (exchange rate of 2005)	CEDRS ^{4 5 6}
Catch sea cucumbers	Monthly catches	CEDRS ^{4 5}
Catch snail nail	Monthly catches	CEDRS
Profit	Average net returns per trip on monthly basis	Calculated based on the CEDRS

² Mahmud and Omer (2003). Available at the Ministry of Fisheries Library, P.O. Box 18, Massawa, Eritrea.

³ Bereket (2004). Available at the Ministry of Fisheries Library, P.O. Box 18, Massawa, Eritrea.

⁴ Afewerki (2000). Available at the Ministry of Fisheries Library, P.O. Box 18, Massawa, Eritrea.

⁵ Habtesselasie and Habte (2000). Available at the Ministry of Fisheries Library, P.O. Box 18, Massawa, Eritrea.

⁶ Ministry of Fisheries (2002). Available at the Ministry of Fisheries Library, P.O. Box 18, Massawa, Eritrea.

2.3. Data analysis

To elucidate patterns in catch rates of different fish categories and relate them to a range of explanatory variables, we may use a variety of techniques in multivariate analysis, which are basically based on two approaches: indirect (unconstrained) and direct (constrained) gradient analysis (ter Braak and Šmilauer, 2002). The goal of indirect gradient analysis is to derive a limited number of canonical axes that explain as much variability between samples (i.e. catch rates of different groups of fish in individual trips) as possible, so as to visualize the similarity between trips (in terms of catch rate and composition) in an ordination diagram (Lepš & Šmilauer, 2003). Resulting patterns in the ordination of samples are related *post hoc* to explanatory variables, hence the name – indirect gradient analysis. Correlations between explanatory variables and the canonical axes are then used to explore the relationship between response and explanatory variables without changing the original ordination pattern. Direct gradient analysis, on the other hand is used to determine the main patterns in the relationship between species abundances and explanatory variables. In direct gradient analysis, a set of relevant explanatory variables need to be specified *a priori*. A disadvantage of direct gradient analysis is that if noisy or redundant variables are included, patterns in species composition can be greatly distorted (McCune 1997).

In this study, we applied both approaches using CANOCO version 4.51 (ter Braak and Šmilauer, 2002). First, we applied detrended correspondence analysis (DCA) for indirect gradient analysis. The length of the gradient in DCA (i.e. the range of sample scores divided by the average standard deviation in family catch rates) indicates whether the relationships between response and explanatory variables is mainly linear (gradient length < 2) or unimodal (gradient length > 4). The total inertia (length of gradient) is used as a measure of multivariate heterogeneity in catch rate or explanatory variables (Minchin, 1987; Herbert and Gelwick, 2003).

Next, we applied direct gradient analysis to examine the relationship between the catch rate of the different groups of fish and the socio-economic factors. Since our main goal was to determine long-term relationships between response and explanatory variables, we aggregated the catch rates of individual landings into monthly averages, thereby reducing temporal fluctuations. Since the relationship between response and explanatory variables after aggregation of catch rates into monthly averages was approximately linear (which was derived from an exploratory DCA), redundancy analysis (RDA) – which is the preferred method in case of linear relationships – was applied in this step. A global Monte Carlo

permutation test (1000 permutations) was performed to determine the significance of the eigenvalues of all or the first canonical axes at $\alpha = 0.05$.

In order to reduce cross-correlations among explanatory variables and thus attain a more parsimonious model, it was important to remove redundant as well as non-significant variables. Here, we used forward selection procedure to include only those variables that explain a significant amount of additional variance at $\alpha = 0.05$ in a Monte Carlo permutation test. Meanwhile, systematic differences in fishing power, which could result in non-random variations in catch rates not related to abundance of fish, were partialled out by incorporating gear and boat in the model as covariables. Finally, we used axis scores as multivariate indices to examine trends in catch composition. In addition, we examined changes in the catch rates of individual families underlying the shifts in catch composition as suggested by the multivariate indices.

3. Results

3.1. Changes in socio-economic variables

A reconstruction of the socio-economic data that were used as explanatory variables in the multivariate analysis is shown in Table 2. The gross returns from the artisanal fisheries remained unchanged despite the expansion of the fisheries, whereas the running costs soared over the years. This resulted in a steady decline in net returns over the years (Fig. 3). In addition, there was a steady decline in the taxonomic resolution of the catch records (Table 2), suggesting a decline in the robustness of the data recording system over the years, due apparently to experienced enumerators leaving the fisheries because of political instability (personal observation).

3.2. Patterns in catch rates and socio-economic variables: indirect gradient analysis

The gradient length of the first axis in the DCA was 4.3, suggesting a unimodal as opposed to a linear relationship between response and explanatory variables (Table 3; Fig 4). The first DCA axis captured 23.3% of the total variability in catch composition whereas the first two axes together captured 35.9% of the total variability.

Table 2. Mean annual ex-vessel prices of fish in real values in Nakfa (per kg); costs of fuel (per liter) and total annual catches of sea cucumbers (tonnes dry weight) in the artisanal fisheries, 1996–2004.

Year	Prices (Eritrean Nakfa)										Taxonomic	
	Tunas	Mackerels	Barracudas	Emperors	Groupers	Snappers	Sea cucumbers	Petrol	Diesel	resolution	Sea cucumbers annual catch	
1996	4.50	9.00	4.50	12.00	13.50	13.50	13.50	3.14	2.04	0.33	27	
1997	4.38	7.50	4.38	10.00	11.25	11.25	250	3.14	2.04	0.97	9	
1998	3.75	6.43	3.75	8.57	9.64	9.64	300	4.07	2.53	0.85	6	
1999	3.28	5.63	3.28	7.50	8.44	8.44	300	5.83	3.47	0.54	8	
2000	2.92	5.00	2.92	6.67	7.50	7.50	350	5.83	3.47	0.56	14	
2001	2.63	4.50	2.63	6.00	6.75	6.75	350	7.70	5.50	0.50	70	
2002	2.39	4.09	2.39	5.45	6.14	6.14	455	7.70	5.50	0.48	200	
2003	5.63	7.50	5.00	7.50	8.75	8.75	500	10.50	5.50	0.47	220	
2004	5.19	6.92	4.62	6.92	8.08	8.08	750	17.20	10.20	0.47	250	

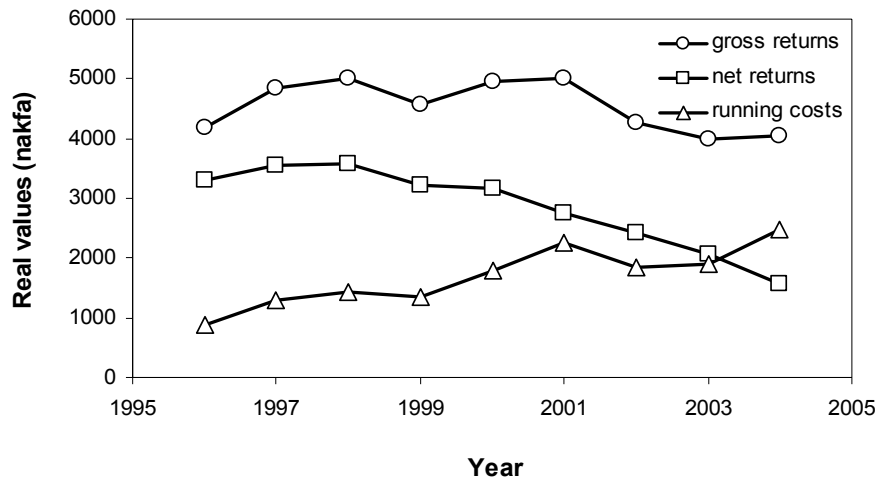

Figure 3. A reconstruction of mean annual running costs, gross returns and net returns per standardized trip in real values.

Table 3. Results of detrended correspondence analysis (DCA) of individual trips, 1996–2004 before and after boat and gear were partialled out as covariables.

	Before		After	
	Axis 1	Axis 2	Axis 1	Axis 2
Eigenvalues	0.72	0.39	0.50	0.41
Lengths of gradient	4.3	3.2	3.397	3.99
Catch rate–socio-economics correlations	0.79	0.46	0.30	0.22
Cumulative percentage variance				
of family catch rate data	23.3	35.9	19.3	35.0
of catch rate–socio-economics relation	70.6	71.1	47.1	52.8
Sum of all eigenvalues		3.08		2.61
Sum of all canonical eigenvalues		0.62		0.14
Percentage of explained variance		20.0		4.6

Using forward regression analysis, the number of explanatory variables were reduced to a total of eight from the initial set of possible explanatory variables (Table 1). The unconstrained species–environment correlation along the first DCA axis was quite high (0.79), while the correlation along the second axis was lower (0.46) (Table 3). It should be

noted that a high correlation does not mean that an appreciable amount of the variance in species data is explained by explanatory variables. This is simply the correlation between scores of samples and explanatory variables on the first axis. The DCA results suggest that 20.0% (sum of all canonical eigenvalues = 0.62 vs. sum of all eigenvalues = 3.08) of the total variability in catch composition could be potentially attributed to the explanatory variables investigated. The first DCA axis captured 70.6% of the variance in the relationship between catch rates and socio-economic variables, whereas the first two axes together captured a cumulative of 71.7%, indicating that the association between catch rates and explanatory variables is far more discernible along the first axis.

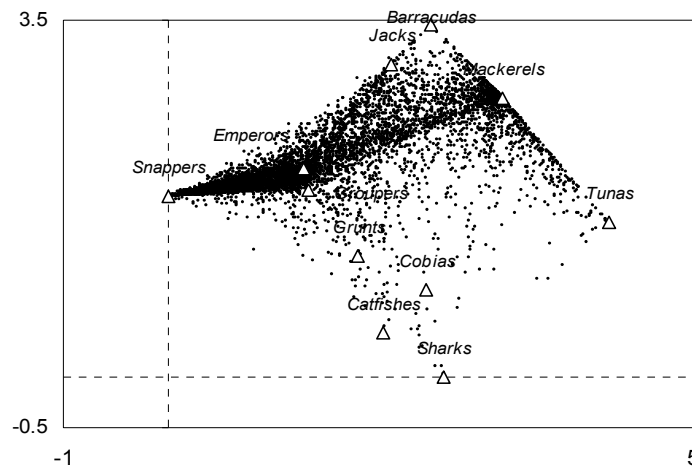

Figure 4. Ordination of sample (points) and species scores (triangles) along the first two axes in detrended correspondence analysis (DCA).

Differences in boat and gear accounted for a considerable amount of systematic (non-random) variations in catch composition, as suggested by the lower sum of all eigenvalues (and hence total variability) observed after partialing out these effects by incorporating them into the analysis as covariables. These two variables alone accounted for 77% of the explained variance in catch composition, as can be inferred from the difference in the percentage of explained variance before and after boat and gear effects were partialled out (20.0% vs. 4.6%) (Table 3). Yet, even though gear and boat type were major source of variation in species composition, changes in gear or boat could not potentially explain trends in catch composition over the years, as implied by the correlations ($r = 0.13, 0.18$, respectively) along the first canonical axis) (Fig. 5, Table 4). On the other hand, year was strongly correlated with the changes in catch composition ($r = 0.77$), followed by the catch

of sea cucumbers ($r = 0.65$), profits ($r = 0.63$) and stability ($r = -0.59$). In addition, the same set of explanatory variables was the most important along DCA axis 2, along which gear and profit were more important than along the first axis ($r = 0.43, -0.73$, respectively). The length of gradient of the DCA ordination diagram is far greater for the sample-species biplots (4.3) than for the explanatory variable plots (0.2), implying that the catches were more heterogeneous than the explanatory variables. The latter explains the relatively low level of explained variability (4.6%) in the model (Table 3).

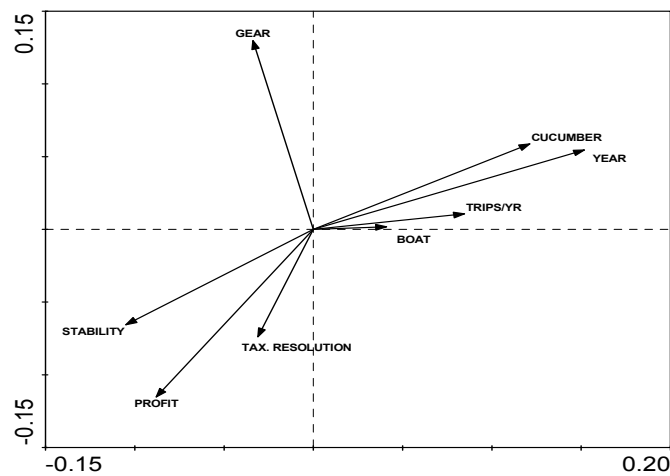

Figure 5. *Post-hoc* projection of explanatory variables on the ordination of response variables in detrended correspondence analysis (DCA).

Table 4. Correlations between explanatory variables and the first two axes in detrended correspondence analysis (DCA) after gear and boat effects were partialled out.

	Axis 1	Axis 2
Year	0.77	0.67
Gear	0.13	0.43
Boat	0.18	0.13
Trips/year	0.39	0.29
Taxonomic resolution	-0.29	-0.39
Stability	-0.59	-0.57
Sea cucumber catch	0.65	0.59
Profit	-0.63	-0.73

The varying concentrations of sample points around family centroids in the DCA biplots suggest that some families are more important than others in the artisanal fisheries (Fig. 4). However, there was a noticeable shift in the spread of sample points around the family centroids, implying shifts in catch composition over the years (Fig. 6).

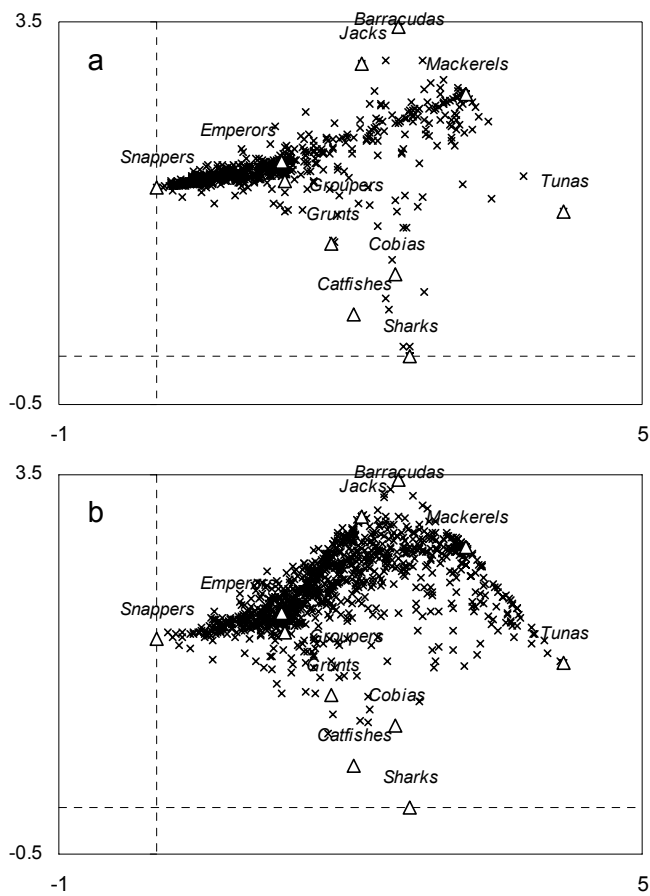

Figure 6. Detrended correspondence analysis (DCA) of sample and species scores of the catches from 1996 (a) and 2001 (b) showing shifts in catch composition over time.

3.3. Relationship between catch rates and socio-economic variables: direct gradient analysis

Given a gradient length of 2.2 for the first axis in the DCA ordination of monthly aggregated catch rates, RDA was applied for direct gradient analysis (Table 5). Just as in

our indirect gradient analysis, the systematic effects of gear and boat on catch composition were removed by incorporating these factors as covariables, as they could otherwise obscure the relationship between catch rates and explanatory variables. The correlation between explanatory and response variable scores along the first RDA axis was relatively high (0.73), while the correlation along the second axis was lower (0.38) (Table 6). An overall significance test of all the canonical axes using a Monte Carlo permutation showed that the relationship between response and explanatory variables was significant ($F = 6.27$, $p = 0.002$), particularly along the first canonical axis ($F = 27.2$, $p = 0.002$). The sum of all canonical eigenvalues of the RDA ordination indicates that the explanatory variables accounted for an overall of 19.4% of the variance in catch composition, the majority of which (82.2%) was captured by the first two axes (Table 6).

Table 5. Results of detrended correspondence analysis (DCA) of monthly aggregated catch rates, 1996–2004 after boat and gear were partialled out as covariables.

	Axis 1	Axis 2
Eigenvalues	0.27	0.12
Lengths of gradient	2.2	2.0
Catch rate–socio-economics correlations	0.77	0.49
Cumulative percentage variance		
of catch rate data	36.8	52.7
of catch rate – socio-economic relation	58.9	73.0
Sum of all eigenvalues		0.73
Sum of all canonical eigenvalues		0.24
Percentage of explained variance		39.2

It can be inferred from the correlations between explanatory variables and the first RDA axis that the shift in catch composition over the years was accompanied by a decline in net profits from finfish catches ($r = -0.44$) (Table 7). Yet, the decline in profits could not only be due to a decline of higher-value species but also to increased fishing costs over the years (Fig. 3). Indeed, the increase in the catches of sea cucumbers was associated with the decline in profits from the finfish catches, suggesting that the decline in profits from finfish fisheries could have prompted a shift toward sea cucumber fishing (Fig. 7).

Table 6. Results of redundancy analysis (RDA) of the relationship between monthly catch rates and the explanatory variables, 1996–2004, after boat and gear were partialled out as covariables.

	Axis 1	Axis 2
Eigenvalues	0.11	0.04
Catch rate–socio-economics correlations	0.73	0.38
Cumulative percentage variance		
of family catch rate data	11.6	16.0
of catch rate–socio-economics relation	59.5	82.2
Sum of all eigenvalues		0.93
Sum of all canonical eigenvalues		0.18
Percentage of explained variance		19.4

Table 7. Correlations between explanatory variables and the first two axes in redundancy analysis (RDA) after gear and boat effects were partialled out.

	Axis 1	Axis 2
Year	– 0.10	– 0.10
Gear	– 0.03	– 0.04
Boat	– 0.03	0.04
Trips/year	– 0.29	– 0.31
Taxonomic resolution	– 0.53	0.05
Stability	– 0.29	0.30
Sea Cucumber	0.51	– 0.18
Profits	– 0.44	0.14

Furthermore, forward selection revealed that the catch of sea cucumbers and the taxonomic resolution of catches in the fisheries are the best predictors of trends in catch composition (marginal $\lambda = 0.06$), followed by profit and number of trips per year (marginal $\lambda = 0.05$) (Table 8). Nevertheless, despite the high degree of variance explained by some of the variables (e.g. taxonomic resolution of the catches, marginal $\lambda = 0.06$ and profit, marginal $\lambda = 0.05$), the additional variance explained by these variables was not significant ($P > 0.05$) (taxonomic resolution of the catches, conditional $\lambda = 0.00$ and profit, conditional $\lambda = 0.01$), suggesting a high degree of multi-collinearity among explanatory variables.

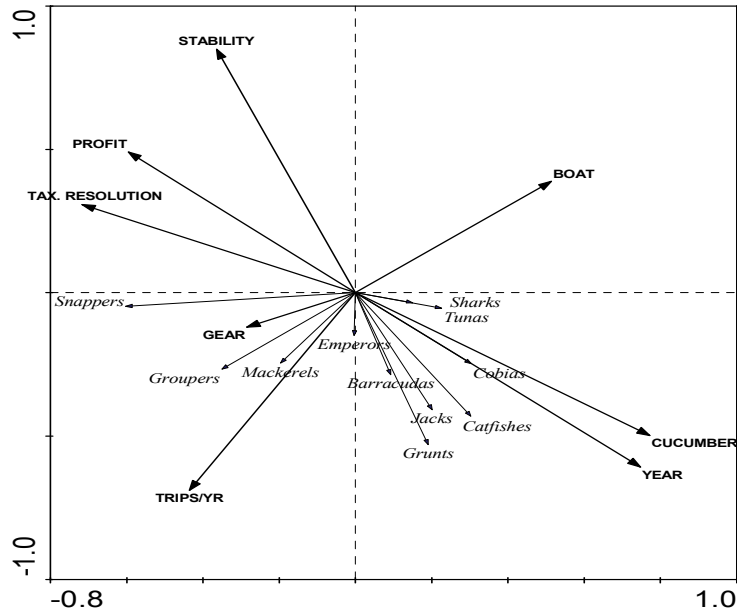

Figure 7. Biplot of the first two axes in redundancy analysis (RDA), showing the relationship between the catch rates of the different families and explanatory variables.

Table 8. Marginal and conditional eigenvalues (λ) for redundancy analysis (RDA); marginal λ refers to the variance in catch composition explained by the variable alone; Conditional λ refers to the additional variance in catch composition explained after the inclusion of other variables in forward selection procedure.

	Marginal λ	Conditional λ	F (conditional λ)	P <
Sea cucumber catch	0.06	0.06	15.41	0.002
Taxonomic resolution	0.06	0	1.31	0.25
Profit	0.05	0.01	1.32	0.216
Trips/year	0.05	0.06	16.48	0.002
Stability	0.05	0.02	5.17	0.004
Gear	0.01	0.02	5.34	0.012
Year	0.01	0	1.11	0.318
Boat	0.01	0.01	1.28	0.244

Aggregation of catch rates on monthly basis resulted in a considerable reduction in variability, as suggested by the difference between the sum of all eigenvalues in DCA before and after aggregation, 2.61 vs. 0.73 (Table 3 and 5). This in turn resulted in an increase in the percentage of explained variance from 4.6 to 39.2%, revealing a stronger association between response and explanatory variables.

3.4. Temporal patterns in catch composition

Because sample scores in RDA are ‘constrained’, DCA axis scores could be used more appropriately as multivariate indices for the analysis of trends in catch composition. Given that the first DCA axis captured most of the variability (23.3%, Table 3) and that the variable year was most strongly correlated with this axis ($r = 0.77$), the shifts in catch composition over the years could be depicted more vividly as changes in mean annual DCA axis 1 scores (Fig. 8). These scores changed over the years for both houris and sambucks, suggesting a shift in catch composition for either boat type. The steady increase in the DCA scores over the years indicates that there was a unidirectional shift in catch composition for both boat types (Fig. 8a).

Trends in DCA axis 1 scores were not as apparent within gear types as within boats, except for the hook and line fisheries (Fig. 8b). This indicates that the shifts in catch composition over the years were more strongly associated with shifts in gear type than with boat type (Fig. 8b). Despite the apparent shifts in catch composition, the species diversity of catches, expressed as of Shannon diversity index, remained almost constant over the years (Fig. 8c), suggesting the importance of a “serial replacement” of species as opposed to a “serial addition” of new species into the catches over the years investigated.

An examination of the changes in catch rates of the various families, underlying the shifts in catch composition as suggested by multivariate indices (Fig. 6; Fig. 8), showed that whereas the contribution to the total catch of the commercially most important fishes, such as (Lutjanidae), sharks (Elasmobranchii) and emperors (Lethrinidae), decreased (from ca. 70% in 1996 to less than 30% in 2004), the proportion of tunas (Scombridae), barracudas (Sphyrinidae) and jacks (Carangidae) increased (from less than 5% to more than 45%).

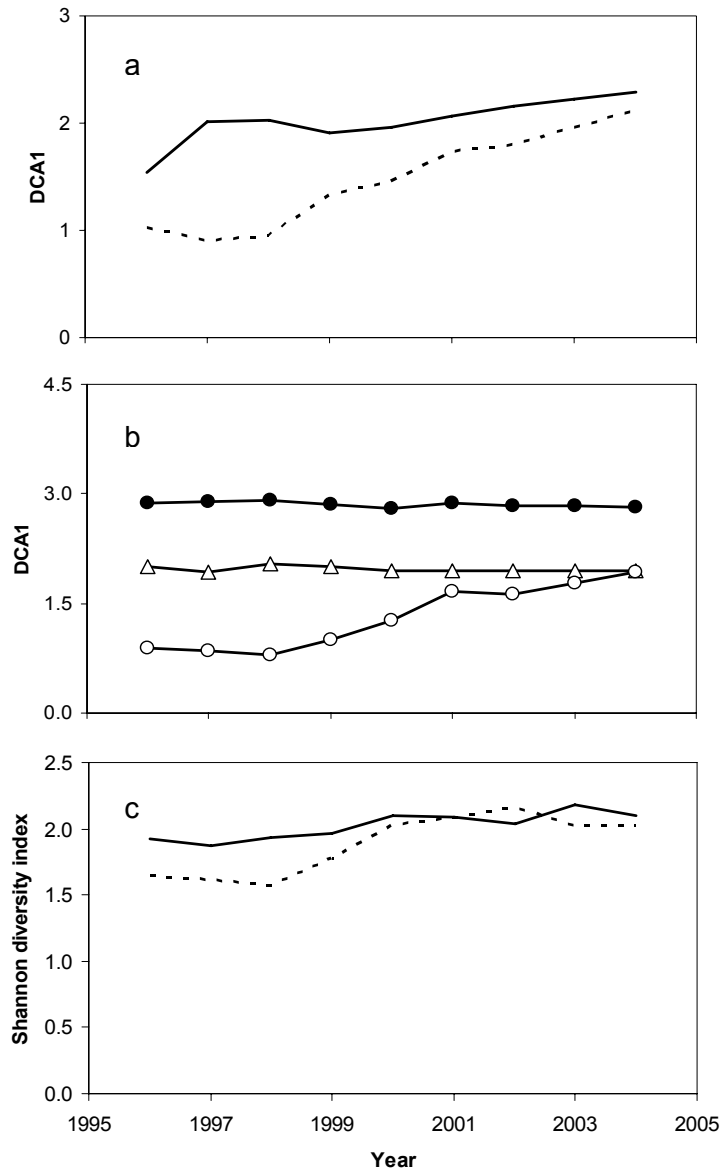

Figure 8. Mean annual axis 1 scores in detrended correspondence analysis (DCA), showing changes in species composition for the two boat categories, solid line, houris; broken line, sambucks (a); Mean DCA axis 1 scores over the years for the different boat gear combinations, solid circles, gillnets; triangles, mixed gillnet and hook and line; open circles, hook and line (b); Mean Shannon diversity index of the catches over the years 1996–2004 (c).

4. Discussion

4.1. Modeling variations in catch composition

Investigating trends in catch rate in relation to both biological and socio-economic factors is important to gain a better insight into the state of fisheries and fish stocks. Multivariate techniques have been shown to be robust ways of assessing the relationship between individual species' abundances and a set of explanatory variables in multispecies studies (Austen and Warwick 1989; Mueter and Norcross, 2000). In the multivariate analysis of catch data from a CEDRS, it is important to adjust catch rates for systematic differences among fishing vessels, fishing locations, seasons etc, which can create non-random variations in catch rate unrelated to abundance. Fishery-dependent data are mostly derived from technically, temporally and spatially heterogeneous fisheries, and systematic variations arising from such differences could confound trends in catch rate and their association with the explanatory variables, which we seek to unravel (Bishop, 2006; Lee and Sampson, 2000).

The CEDRS from the artisanal fisheries of Eritrea, being complete with information on gear and boat type used on individual fishing trips, allows us to account for systematic variations in fishing power among vessels and gears and subsequently remove them (they accounted for 15.4% of the overall variability in catch composition; Table 3). Besides technical heterogeneity, seasonality might also be expected to have a systematic effect on catch rate and species composition. However, seasonal effects were not found to account for a significant amount of variability in catch rates in these fisheries.⁷ Moreover, besides the rise and fall of catch rates across fishing gear and craft, there may also be other non-random differences in catch rates due to other factors, e.g. fishing location. Our analyses of trends in the artisanal fisheries using data from the CEDRS could thus greatly benefit if the data consisted of details on the spatial distribution of fishing effort. Nevertheless, Tsehaye et al. (2007) previously found no changes in the spatial allocation of fishing effort at a 50x50 km scale over the years. Nor were there any significant differences in catch rate among fishing locations that could potentially confound trends in catch composition. Yet, shifts in spatial allocation of effort might have taken place at small spatial scales, but that could not possibly be detected because of the low spatial resolution of the data.

⁷ Chapter 4.

The interpretation of trends in fishery-dependent data could further be complicated by non-random variability arising from possible inconsistency in taxonomic resolution of the data or differences in enumerators' expertise (such as novice and old hand) (Lee and Sampson, 2000). However, in the artisanal fisheries, there were no systematic variations stemming from changes in taxonomic resolution of the data over the years investigated, relieving us of the need to adjust catch rates for such changes to ensure randomness in the distribution of data. This is apparently because our analysis was performed at a higher taxonomic level, i.e. the family level. Our results are consistent with that of McCune et al. (1997) on the effect of having different levels of sampling expertise in large-scale lichen studies, suggesting that an accurate depiction of community composition could be made even when the data on species richness contain substantial observer error.

Once the systematic effects of gear and boat were removed, our model results revealed a significant – albeit small (5.0%) – degree of association between the explanatory variables and catch composition. For abundance data, the percentage of explained variance is usually quite low, as species data are normally very noisy. Thus, a low level of explained variance is often not a cause for concern in multivariate analysis of ecological (and hence fisheries) data (ter Braak and Šmilauer, 2002). Nevertheless, the catch rate data were aggregated into monthly averages, the analysis of which resulted in a higher percentage of explained variance (19.4 vs. 5.0 %). This suggests that aggregation of data over time acts to dampen random fluctuations (the noise) in catch rate, allowing the relationship between the dependent and explanatory variables to become more apparent (van Densen, 2001).

4.2. Changes in catch composition vs. socio-economic and biological variables

Our analysis revealed a gradual change in catch composition in the artisanal fisheries over the years investigated, with the catch rates of snappers (Lutjanidae), sharks (Elasmobranchii) and emperors (Lethrinidae) decreasing and those of jacks (Carangidae), tunas (Scombridae) and barracudas (Sphyraenidae) increasing. The shifts in catch composition in these fisheries may imply a shift in the relative abundance of fishes, particularly given that they involve a decline in the catch rate of higher-value species. This type of instability in catch composition is often associated with anthropogenic impacts on fish stocks (O'Connell et al., 2004; Okada et al 2005). Thus, one might deduce removals by fisheries to have caused the changes in species composition in the artisanal fisheries, with higher-value species being gradually replaced by less valuable fishes.

Even though the changes in catch composition could be interpreted as reflecting changes in the underlying fish community structure, they were significantly associated with changes in technical and economic variables, which explained 19.4% of these changes. Therefore, it is likely that some of the changes in catch composition were caused by factors that are not related to a decline of fish stocks. Generally, even if fishing could be a major cause of changes in catch composition, it is also possible for catch composition in multispecies fisheries to be altered due to changes in fishing strategies (Caddy, et al. 1998; Hampton et al., 2005; Cinner and Mc Clanahan, 2006). For the artisanal fisheries of Eritrean, the changes in catch composition were not more strongly associated with trends in effort (expressed as the number of trips over the years) than with the other socio-economic variables, underlining the importance of socio-economic factors in these fisheries. The most important factors explaining long-term trends in catch composition in these fisheries were sea cucumber catches and profits. In addition, our analysis showed that the decline in profits was not only due to changes in catch composition but also due to the rise in fishing costs (Fig. 3), stressing the importance of socio-economic circumstances in these fisheries. Even though the prices of reef-associated fishes remained higher than that of pelagic fishes, the rise in fishing costs combined with a higher rate of increase in prices of pelagics over the years could have prompted changes in fishers' preferences.

In the face of declining economic returns (although societal and traditional values could be equally important), fishers might deem some of their target fish economically extinct, (Kronen, 2004). The effects of increased socio-economic hardships have actually been reflected by the high proportion of latent fishing capacity in the artisanal fisheries (Tsehaye et al., 2007). Nevertheless, our results suggest that, despite the steady decline in the income from finfish fisheries, the number of fishing trips per year did not decline in these fisheries, suggesting that the decline in profit from finfish fisheries over the years was being offset by soaring incomes from sea cucumber fisheries. These scenarios support the assertion (on the part of various fishers, personal communication) that the increase in sea cucumber fishery might be related to and followed the decline in profits from the finfish fisheries, which have been an economic mainstay among the artisanal fishers.

Meanwhile, we showed that even if shifts in catch composition are normally more likely to be associated with changes in fishing gear (Okada et al., 2005), there were no clear changes in gear composition over the years explaining the shifts in catch composition in these fisheries (Fig. 7). Nor were there any clear changes in gear specifications, as the mesh size

of gillnets and the size of hooks remained unchanged upon the expansion of the artisanal fisheries over the years (Tsehaye et al., 2007).

Overall, the results from this study highlight the effects of changes in socio-economic circumstances on fish targeting strategies in the artisanal fisheries. Nevertheless, our results could not strongly substantiate the hypothesis that the cause to the shifts in catch composition is mainly one of economics, because the shifts were not actually strongly associated with changes in the economic variables investigated. Rather, the results support the hypothesis that the shifts in catch composition are unlikely to be due exclusively to shifts in fish community structure.

Combining the above speculations, it may be argued that fishing pressure and socio-economic changes are likely to have acted in concert to cause the shifts in catch composition observed in the artisanal fisheries. However, a direct statistical link between the changes in CPUE in the artisanal fisheries and possible changes in the underlying fish community structure could not be established, as it requires confrontation of our results with biological data, which were unfortunately not available for these fisheries. The most commonly used biological indices for the assessment of fish stocks include the mean trophic level, mean size of fish in catch, or the slope of biomass size spectra (Pauly et al., 1998; Campana et al., 2006).

Finally, our assessment of the effects of socio-economics on the artisanal fisheries of Eritrea appears to be consistent with Sheppard (2000), suggesting that due to under-developed market structure, most Red Sea fisheries have not been at risk of overexploitation. In the artisanal fisheries, the introduction of new target species, i.e. the sea cucumbers, into the artisanal fisheries might seem – at least at face value – a desirable development, potentially promoting sustainable exploitation by spreading out existing fishing pressure over a wider range of target organisms (Walters and Martell, 2004; Essington et al., 2006). In conclusion, our findings stress the need to address socio-economic factors alongside the biological dynamics of fish stocks, as they could derive major shifts in species targeting or lead to the concentration of fishing effort on selected species (sea cucumbers in this case) (Larkin, 1978; Charles 1988; Hilborn and Walters, 1992; Branch et al., 2006; Grafton, et al., 2006).

Acknowledgements

We would like to thank the Research and Statistics Division of the Ministry of Fisheries, Eritrea for providing us with the catch and effort data and for their helpful discussion. We are also grateful thankful to Dr. H.A.J. Moll for his advice on the socio-economic aspects of the analysis. Our thanks also go to Prof. Johan Verreth for his comments on the initial manuscript. This study was supported by the Netherlands Organization for International Cooperation in Higher Education (Nuffic) as part of the MBF-UoA-MHO project.

References

- Anderson, P.J., Blackburn, J.E., and JOHNSON, B. A., 1997. Declines of forage species in the Gulf of Alaska, 1972–1995, as indicators of regime shift. In: Proceedings of the International Symposium on the Role of Forage Fishes in Marine Ecosystems. November 13–16, 1996, Anchorage, Alaska. Baxter, B. S. (ed.), University of Alaska Alaska Sea Grant Rep., 97–01, pp. 531–543.
- Afewerki, B., 2000. Socio-economic Survey of Southern Red Sea: The case of fishing villages. Ministry of Fisheries, Assab, Eritrea.
- Austen, M.C., and Warwick, R.M., 1989. Comparison of univariate and multivariate aspects of estuarine meiobenthic community structure. *Estuarine Coastal Shelf Sci.* 2923–2932.
- Bishop, J., 2006. Standardizing fishery-dependent catch and effort data in complex fisheries with technology change. *Rev. Fish. Biol. Fish.* 16, 21–38.
- Bereket, H., 2004. Field report on industrial sea cucumber harvest. Ministry of Fisheries, Massawa, Eritrea.
- Branch, T.A., Hilborn, R., Haynie, A.C., Fay, G., Flynn, L., Griffiths et al, 2006. Fleet dynamics and fishers behavior: lessons for fisheries managers. *Can. J. Fish. Aquat. Sci.* 63, 1647–1668.
- Caddy, J. F., Csirke, J., Garcia, S. M., and Grainer, R. J. R., 1998. How pervasive is “Fishing Down Marine Food Webs”? *Science* 282, 183.
- Campana, S. E., Marks, L., Joyce, W., and Kohler, N. E., 2006. Effects of recreational and commercial fishing on blue sharks (*Prionace glauca*) in Atlantic Canada, with inferences on the North Atlantic population. *Can. J. Fish. Aquat. Sci.* 63, 670–682
- Charles, A. T., 1988. Fishery Socioeconomics: A Survey. *Land Economics*, 64, 276–295.
- Cinner, J.E., and McClanahan, T.R., 2006. Socioeconomic factors that lead to overfishing in small-scale coral reef fisheries of Papua New Guinea. *Environ. Conserv.* 33, 73–80.

- Dulvy, N.K., Polunin, N.V.C., Mill, A.C., and Graham, N.A.J., 2004. Size structural change in lightly exploited coral reef fish communities: evidence for weak indirect effects. *Can. J. Fish. Aquat. Sci.* 61, 466–475.
- Essington, T.E., Beaudreau, A.H., and Wiedenmann, J., 2006. Fishing through marine food webs. *Proc. Nat. Acad. Sci.* 103, 3171–3175.
- Ghebremichael, A., and Haile, S., 2006. Commercial fishes of the Eritrean Red Sea. Apex Publishing Ltd., Essex, England, 266 pp.
- Grafton, R. Q., Arnason, R., Bjørndal T., Campbell, D., Campbell, H., Clark, C. W. et al., 2006. Incentive-based approaches to sustainable fisheries. *Can. J. Fish. Aquat. Sci.* 63, 699–710.
- Habteselassie, D., and Habte, I., 2000. Basic Fisheries Statistics of Eritrea (Massawa). Internal Report. Research and Training Division, Min. of Fisheries, Massawa, 36 pp.
- Hampton, J., Sibert, J.R., Kleibert, P., Maunder, M.N., and Harly, S.J., 2005. Decline of pacific tuna populations exaggerated? *Nature* 434, E1–E2.
- Herbert, M.E., and Gelwick, F.P., 2003. Spatial variation of headwater fish assemblages explained by hydrologic variability and upstream effects of impoundment. *Copeia* 2003, 273–284.
- Hilborn, R., and Walters, C.J., 1992. Quantitative fish stock assessment. Choice, dynamics and uncertainty. Chapman and Hall, London, 570 pp.
- IMF, 2005. Eritrea: 2005 Article IV consultation – Staff report, public information notice on the executive board discussion and statement by the executive director of Eritrea. Country report No. 03/165.
- Kronen, M., 2004. Fishing for fortunes? A socio-economic assessment of Tonga's artisanal fisheries. *Fish. Res.* 70, 121–134
- Larkin, P.A., 1978. Fisheries management: an essay for ecologists. *Annu. Rev. Ecol. Syst.*, 9: 57–73.
- Lee, Y.W., and Sampson, D.B., 2000. Spatial and Temporal Stability of Commercial Groundfish Assemblages off Oregon and Washington as Inferred from Oregon Trawl Logbooks. *Can. J. Fish. Aquat. Sci.* 57, 2443–2454.
- Lepš, J., and Šmilauer, P., 2003. Multivariate analysis of ecological data using CANOCO. Cambridge University Press, pp 1–269.
- McCune, B. 1997. Influence of noisy environmental data on canonical correspondence analysis. *Ecology* 78, 2617–2623.
- McCune, B., Dey, J. P., Peck, J. E., Cassell, D., Heiman, K., Will-Wolf, S. and Neitlich, P. N., 1997. Repeatability of community data: species richness versus gradient scores in large-scale lichen studies. *Bryologist* 100, 40–46.

- Mahmud, S., and Omer, A., 2004. Current exploitation of sea cucumber fishery in Eritrea. Ministry of Fisheries, Massawa, Eritrea.
- Minchin, P.R. 1987. An evaluation of the robustness of techniques for ecological ordination. *Vegetatio* 69, 89–107.
- Ministry of Fisheries, 2002. Executive Summary of the Ministry of Fisheries Report. Massawa, Eritrea.
- Morgan, G., 2006. Country review: Eritrea. In: De Young, C. (Ed.), Review of the state of world marine capture fisheries management: Indian Ocean. FAO Fisheries Technical Paper. No. 488, FAO, Rome, 458 pp.
- Moussalli, E., and Haile, T., 2001. Ex post Evaluation of the Semhar Fisheries Rehabilitation Project ERI/92/001(UNDP) ERI/92/C01 (UNCDF) and Capacity Building for the National Marine Resources Programme ERI/94/001 (UNDP). UNDP, 53 pp.
- Mueter, F.J., and Norcross, B.L., 2000. Changes in species composition of the demersal fish community in nearshore waters of Kodiak Island, Alaska. *Can. J. Fish. Aquat. Sci.* 57, 1169–1180.
- O’Connell, M.T., Cashner, R.C., and Schieble, C.S., 2004. Fish assemblage stability over fifty years in Lake Pontchartrain estuary: Comparisons among habitats using canonical correspondence analysis. *Estuaries* 27, 807–817 .
- Okada, E.K., Agostino, A.A., and Gomes, L.C., 2005. Spatial and temporal gradients in artisanal fisheries of a large Neotropical reservoir, the Itaipu Reservoir, Brazil. *Can. J. Fish. Aquat. Sci.* 62, 714–724.
- Pauly, D., Christensen, V., Dalsgaard, J., Froese, and Torres, F.C., 1998. Fishing down marine food webs. *Science* 279, 860–863.
- Reynolds, J.E., Appleton, J., Bellemans, M.S., Bonzon, A., and Christy, L.C., 1993. The fisheries of Eritrea, part. 1: Sector review. part. 2: Proposed national fisheries strategy and development program. Terminal Report, FI:FAO/TCP/ERT/2251. FAO, Rome
- Sheppard, C.R.C., 2000. The Red Sea. In: Sheppard, C.R.C. (Ed.), *Seas at the Millennium: An Environmental Evaluation*. Pergamon, Oxford, pp. 35–45.
- ter Braak, C. J. F., and Smilauer, P., 2002. *Canoco for Windows Version 4.51*. Biometris – Plant Research International, Wageningen, The Netherlands, 499 pp.
- Tsehaye, I., Machiels, M.A.M., and Nagelkerke, L.A.J., 2007. Rapid shifts in catch composition in the artisanal Red Sea reef fisheries of Eritrea. *Fish. Res.* 86, 58–68.
- Tsehaye, I., and Nagelkerke, L.A.J., in press. Exploring optimal fishing scenarios for the multispecies artisanal fisheries of Eritrea. *Ecological Modelling*.
- Van Densen, W.L.T., 2001. On the perception of time trends in resource outcome. Its importance in fisheries co-management, agriculture and whaling. PhD thesis, Twente University, Enschede, the Netherlands. 299pp.

Van Oostenbrugge, J.A.E., van Densen, W.L.T., and Machiels, M.A.M., 2004. How the uncertain Outcomes associated with aquatic and land resource use affect livelihood strategies in coastal communities in the Central Moluccas, Indonesia. *Agricultural Systems* 82, 57–91.

Walters, C.J., and Martell, J.D., 2004. *Fisheries Ecology and Management*. Princeton University Press, Princeton, NJ, 399 pp.

CHAPTER 4

Improving the effectiveness of monitoring programs in multispecies fisheries through aggregation of catch data into ecological categories

Iyob Tsehaye^{1,2}, Paul A.M. van Zwieten¹ & Leopold A.J. Nagelkerke¹

¹*Aquaculture and Fisheries Group, Wageningen University, Wageningen Institute of Animal Sciences, Marijkeweg 40, 6709 PG Wageningen, the Netherlands.*

²*Department of Marine Sciences, University of Asmara, P.O. Box 1220, Asmara, Eritrea*

Abstract

Elucidating trends in catch rates is important to monitor the state of fish stocks and thereby guide fisheries management action. In many fisheries, aggregate data provide much of the evidence for trends in catch rates, since trends in individual species may be blurred by high variability. Aggregation of catch data across all species may however obscure actual trends in the catch rates of individual species. Yet, an accurate depiction of temporal patterns in catch rates can be made by aggregating multispecies catch data into homogenous categories, which can be defined based on life histories and spatial distribution of species. Multispecies catch data from the artisanal reef fisheries of Eritrea could be aggregated into three ecological categories, which were defined based on the degree of co-occurrence of species in the catch, without considerable loss of information on trends. Since no contrasting life histories were found among the target species, these categories just represent spatially distinct groups of fishes, including reef-associated demersals, open-water pelagics and near-reef pelagics. Aggregation of the multispecies catch data into these categories was found to dampen inter-annual fluctuations in catch rates, allowing long-term trends to become more apparent. Aggregation of catch data also resulted in a considerable reduction in random variability in catch rate, allowing optimization of sampling programs in the artisanal fisheries. The sample size required for the estimation of annual catch rates with a maximum relative error (*mre*) of 10% was reduced by more than 50% after aggregation of catch data into the three ecological categories. Generally, the effectiveness of monitoring programs in multispecies fisheries can be improved through aggregation of species catch data into fewer ecological categories. Aggregation of catch data results in reduction of inter-annual variability in catch rates, thereby improving the statistical power to detect trends. Aggregate catch rates also provide better insight into community-level responses to exploitation. Moreover, the reduction in random variability upon aggregation of catch rates has important consequences for the optimization of sampling programs, minimizing sample size requirements for the estimation of annual catch rates, and thereby allowing the reallocation of sampling resources for the collection of a wider range of data.

Keywords: Aggregation; Catch rate; Co-occurrence; Eritrea; Multispecies; Statistical power; Trends; Variability.

1. Introduction

Monitoring trends in catch rates is important to inform fisheries management decisions. In most tropical reef fisheries, fishery-dependent sampling through a catch and effort data recording system (CEDRS) is often the only source of information available to monitor fish stocks, particularly given the financial constraints for fisheries assessment and management in these fisheries (Larkin, 1982; Jennings and Lock, 1996; Sadovy, 2005; Vasconcellos and Cochrane, 2005). Yet, prudent use of existing time-series of fishery-dependent data may still allow an effective monitoring of fisheries and fish stocks (Hilborn and Walters, 1992; Sparre and Venema, 1998). This can in turn permit the streamlining of existing monitoring programs in such a way as to allow the acquisition of a wider range of fisheries data.

The effectiveness of a monitoring program in multispecies fisheries can be improved through aggregation of catch data (Anderson et al., 1997; van Oostenbrugge et al., 2002). In fact, aggregate data provide much of the evidence for trends in catch rates in many fisheries, because trends in individual species are often blurred by high variability (Anderson et al., 1997). Aggregation of species catch rates normally results in a reduction in temporal variability, thereby improving the statistical power to detect trends (Peterman, 1990; Nagelkerke and van Densen, 2007).

In monitoring multispecies fisheries, the simplest approach to elucidating trends in catch rates is to ignore the heterogeneity in species' responses to fishing and use catch and effort data aggregated across all species (Halls et al., 2006; Lorenzen et al., 2006). However, aggregation of catch data across all species may obscure trends in the abundance of individual species, as total catch rate often tends to remain constant despite varying trends in the abundance of these species (Doak et al., 1998; van Oostenbrugge et al., 2002). Therefore, to elucidate trends in multispecies fisheries more accurately, it will be essential to aggregate catch data into homogenous species categories (Pet-Soede, 1999, Lorenzen et al., 2006).

For monitoring purposes, multispecies catch data may appropriately be aggregated into fewer categories, defined *a priori* based on their life histories. Indeed, since species with similar life-history traits, e.g. growth rate, longevity, fecundity, age at maturity, intrinsic rate of population increase etc., are likely to exhibit similar responses to fishing, they can be monitored jointly as a single entity, without significant loss of multispecies information (Jennings et al., 1999a,b; van Oostenbrugge et al., 2002). Yet, from a fisheries assessment

point of view, species can only be monitored jointly if they also belong to the same fish assemblage, i.e. they share a common distribution range at the scale of operation of the fisheries. The degree of co-occurrence of species in the catches can be used to examine the distribution patterns of the target species, and thereby identify species categories. In principle, the higher their degree of co-occurrence in the catch, the more likely a given pair of species belongs to the same fish assemblage. As such, a high degree of co-occurrence of species in the catches can be used as a second criterion for defining species categories (van Oostenbrugge et al., 2002). Once species are aggregated into fewer categories based on the above two criteria, an *a posteriori* validation should be made to verify that aggregation of catch data would not result in significant loss of multivariate (i.e. multispecies) information on trends (Clark and Warwick, 2001).

In this study, we use the artisanal reef fisheries of Eritrea as a case study to illustrate approaches to improving the effectiveness of monitoring programs. These fisheries were launched into a renewed development in 1991, mainly exploiting coral reef fish resources off Eritrea's Red Sea coast (Tsehaye et al., 2007). The artisanal fisheries mostly target high-value, reef-associated demersal fishes, such as groupers (Serranidae), snappers (Lutjanidae) emperors (Lethrinidae), and pelagic fishes, such as mackerels and tunas (Scombridae). Apart from a routine collection of catch and effort data, there has not been a comprehensive monitoring of the state of fish stocks and the fisheries (Tsehaye et al., 2007). This underlines the need for the development of an effective monitoring program, particularly given the continued expansion of the fisheries.

The CEDRS in the artisanal fisheries of Eritrea is based on a complete enumeration of catch and effort statistics. Nevertheless, this CERDS is rather inefficient, as it is restricted to the collection of only catch and effort data, excluding other biologically important information. Indeed, as the artisanal fisheries continue to expand, even the enumeration of catch and effort statistics alone could also become infeasible, particularly given the multispecies and multigear nature of the fisheries. Instead, a sample-based scheme, in which sampling resources are apportioned properly, can ensure an effective monitoring of catch and effort, while allowing the collection of a wider range of data for fish stock assessment (Peterson and Rabeni, 1995; Stamatopolous, 2002). For the artisanal fisheries, we explore the improvements in statistical power to detect trends upon aggregation of catch data of individual species into different levels (families, ecological categories, total catch rate). In addition, we examine the consequences of the reduction in random variability upon

aggregation of catch data for the optimization of the catch and effort sampling strategy in these fisheries.

2. Materials and methods

2.1. Characteristics of the fisheries

The artisanal fisheries of Eritrea mainly take place in inshore waters along the Red Sea coast. These fisheries are mostly concentrated around the islands of the Dahlak archipelago, which are scattered between 20 km to 160 km from Eritrea's main port of Massawa (Fig. 1). Most fishing operations are carried out using two types of traditional wooden boats: houris and sambucks. Houris are 4 to 9 m in length and equipped with an out-board engine (35 HP), while sambucks are 12 to 17 m long and have an inboard engine (50HP). These boats are equipped with gillnets, hook and line or a combination of both, forming six boat–gear combinations in the artisanal fisheries (Tsehaye et al, 2007). Fishers mainly use gillnets for the capture of pelagic fishes, and hook and line for capturing demersals.

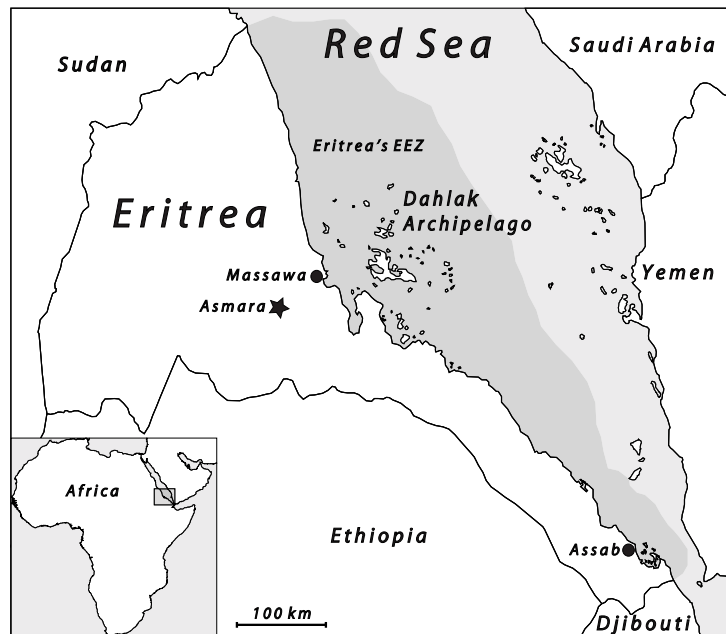

Figure 1. Map of Eritrea showing the islands of the Dahlak Archipelago and the fishing harbors of Massawa and Assab.

2.2. *The database*

The present study is based on the CEDRS for the artisanal fisheries, as instituted by the Ministry of Fisheries. Fisheries data have been collected since the artisanal fisheries were launched into a renewed development in 1991. However, a systematic catch and effort data recording scheme, involving a complete enumeration of catch and effort statistics, was introduced only in 1996. Thus, the present study is based on the data from the years 1996–2002. Although designed for recording catches at species level, the CEDRS mainly comprises of catches identified only to family level. Therefore, this study is based mainly on an analysis at a family level. Our analysis includes eleven families (representing 71 species, see Appendix), which make up about 95% of the total catch by weight.

2.3. *Aggregation of multispecies catch data*

We examined if the target species or families could be divided into different categories with contrasting life histories based on three attributes that have been suggested to be good predictors of the varying responses of different species to fishing (Jennings et al., 1999a,b; Froese and Pauly, 2007). These attributes were maximum length (L_{\max}), intrinsic rate of population growth (r) and trophic level (TL). Data on life-history traits of the different species were obtained from FishBase (Froese and Pauly, 2007). In addition, analysis of degree of co-occurrence of families in the catches was made with the aim to identify spatially distinct fish assemblages. The significance of degree of co-occurrence between families was determined by comparing the actual probability of co-occurrence of a given pair of families in the landings with their theoretical probability of co-occurrence. Theoretical degree of co-occurrence was calculated for each pair of families by multiplying the proportions of occurrence in the catch of the individual families. The significance of the actual degree of co-occurrence was then tested using a χ^2 -test. A matrix of pair-wise χ^2 probabilities between the eleven families was used to categorize the families using cluster analysis (hierarchical agglomerative clustering). The resulting clusters were examined to check whether they represent ecologically meaningful categories or were merely statistical artifacts.

In order to verify that aggregation of catch data into these categories would indeed result in little loss of multivariate information, we compared patterns in catch rate using non-metric multidimensional scaling (NMDS) in PRIMER[®] (Clark and Warwick, 2001). NMDS ordinations of Bray-Curtis similarity matrices of monthly catch rates were constructed at

different levels (species, family, ecological categories and total catch rate). The correlation between the NMDS ordinations at different levels was calculated using Spearman rank correlation. The significance of the correlation was tested by a Monte Carlo permutation procedure (1000 runs). The goodness of fit of the resulting two-dimensional ordination was measured using the stress index, with stress values <0.15 indicating a good fit (Clark and Warwick, 2001). Meanwhile, we examined whether trends in athc rate at family level actually represent patterns in catch rate of individual species, using the data from 1997, when catches were mostly identified to species level.

2.4. Statistical power analysis

To examine the consequences of aggregation for the effectiveness of monitoring programs, we calculated the number of years of data required to detect trends in catch rates before and after aggregation of catch data. The number of years of data required to detect a trend b in a time-series can be calculated for given levels of type I and type II errors, α and β , and the trend-to-noise ratio (b/s) ratio using the equation (van Zwieten et al., 2002):

$$\frac{|b|}{s} \sqrt{\frac{n(n-1)(n+1)}{12}} \geq (t_{\alpha/2} + t_{\beta})$$

Where b = trend parameter (slope) of a linear regression; s = standard deviation of the residuals; n = the number of observations, $t_{\alpha/2}$, t_{β} = test statistic from the Student's t -distribution. This equation is solved iteratively. All data were \log_{10} -transformed to fulfill the assumption of normality and homoscedasticity. This procedure was repeated for the different families. The residual variance of the \log_{10} -transformed data was back-transformed to obtain an actual estimate of the coefficient of variation (CV) using the relationship (Aitchison and Brown, 1957):

$$CV = 100 * \sqrt{10^{s^2} - 1}$$

2.5. Optimization of sampling design

The sample sizes required for the estimation of total catch at a desired level of precision (expressed as maximum relative error, mre) were estimated for different levels of aggregation using the mean and standard deviation of the catch per unit effort (CPUE) and

effort at these levels of aggregation. Alongside, to determine the need for the implementation of stratified sampling in the CEDRS, we tested for significant differences in catch rate between the six boat–gear combinations using the GLM procedure in SAS (SAS Institute Inc. 1999).

The number of samples (n) required to attain a desired level of precision in a stratified random sampling depends on the standard deviation (s) and a test statistic from the Student's t -distribution (t), which varies with the confidence level (Snedecor and Cochran, 1989), and is given as:

$$n = \frac{t_{n-1}^2}{mre_x^2 \cdot \bar{X}^2} \cdot \sum_h \left(\left[\frac{N_h^2 \cdot s_h^2}{N^2 \cdot n_h} \right] \cdot \left[1 - \frac{n_h}{N} \right] \right) \cdot \left(1 - \frac{n}{N} \right) \cdot 100 \%$$

where N_h = the total number in stratum h , n_h = the number of samples from stratum h ; s_h^2 = sample variance in stratum h ; \bar{X} = estimated population mean. This equation is solved iteratively. We determined the sample size requirements for the estimation of annual catch for a range of $mres$.

Since total catch is given as a product of the CPUE and effort, i.e., annual catch ($\text{kg}\cdot\text{year}^{-1}$) = CPUE ($\text{kg}\cdot\text{trip}^{-1}$) \cdot annual effort ($\text{trips}\cdot\text{year}^{-1}$), the standard deviation of annual catch is calculated in the form of a “variance of a product” as (Mood et al., 1974):

$$s_{\text{annual catch}} = \sqrt{f^2 \cdot s_{CPUE}^2 + CPUE^2 \cdot s_f^2 + s_{CPUE}^2 \cdot sd_f^2}$$

3. Results

3.1. Aggregation of catch data

Whereas some families exhibited a downward trend and others an upward one, the total catch rate remained almost constant over the years investigated, suggesting a considerable loss of multivariate information upon aggregation of catch data across all species (Fig. 2). Thus, an accurate depiction of temporal patterns in catch rates could only be made by aggregating the catch data into different categories.

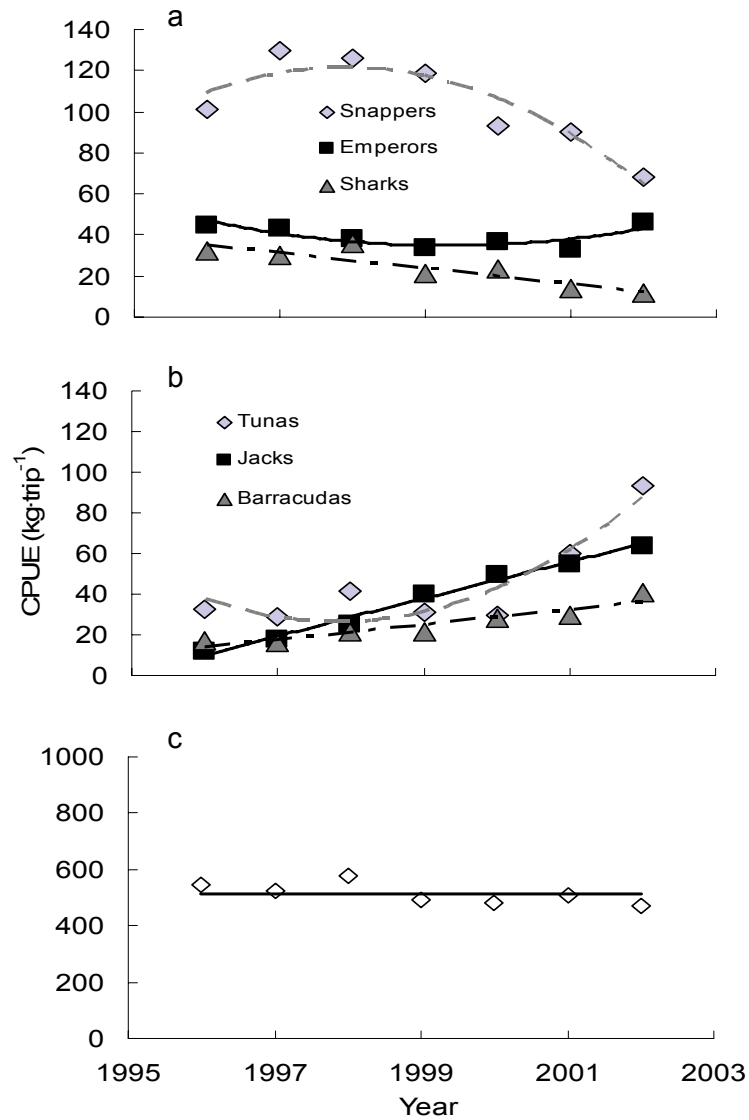

Figure 2. Trends in the catch rate of individual families (a) and (b) and in total catch rate (c) in the artisanal fisheries. Mean CPUE is shown with a horizontal line if trend is not significant.

Since the target fishes were found to have relatively closely related life histories – all being slow growing, of high trophic level, and with low intrinsic rate of population growth – they could not be divided into distinct categories with contrasting life histories (Fig. 3;

Appendix). As a result, the categorization of fishes was reflective of solely their spatial distribution. The analysis of co-occurrence showed that there was a higher degree of co-occurrence between some pairs of families than others (Table 1). Clustering of families based on their degrees of co-occurrence in the landings resulted in three different categories, which are apparently ecologically distinct. These categories were (a) reef-associated demersals, including snappers, emperors and groupers; (b) open-water pelagics, including mackerels, tunas, barracudas and cobias; and (c) near-reef pelagics, representing jacks, sharks, sea catfishes and grunts (Fig. 4). However, sharks were found to have significantly high degrees of co-occurrence with all the other families, implying that they have a wider range of distribution and may not be appropriately assigned to any one category. Similarly, cobias also showed significantly high degrees of co-occurrence with the families in both categories (b) and (c).

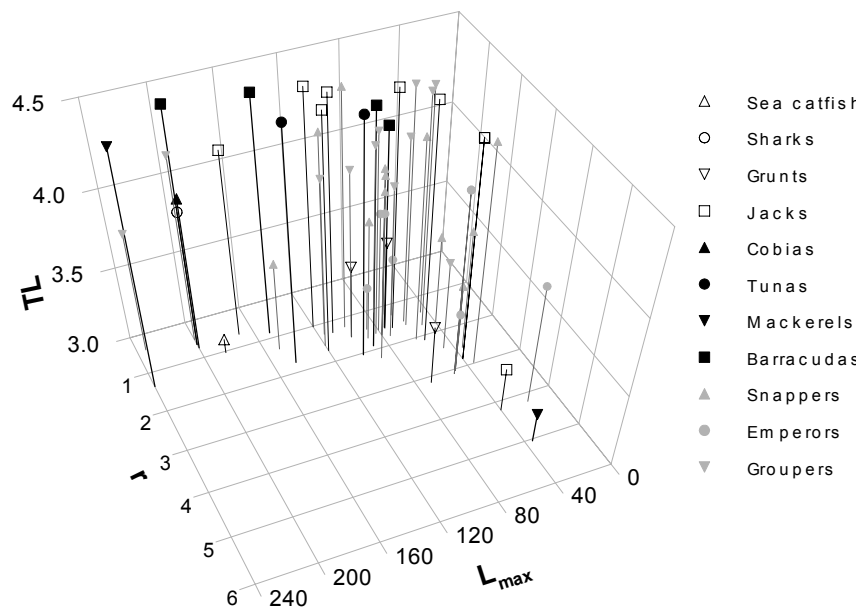

Figure 3. The dispersion of life histories of the different families with respect to three attributes: maximum length (L_{max} , cm), intrinsic rate of population increase (r_{max} , year^{-1}) and trophic level (TL). (See appendix for details). The families are coded according to the three categories used in the analysis (see text for explanation).

Table 1. Analysis of co-occurrence of the different families in the catches. -: significantly exclusive occurrence; 0: independent occurrence; +: significantly high co-occurrence (χ^2 -test, $p < 0.05$). Family numbers on the top row correspond to the family numbers on the first column.

Family	1	2	3	4	5	6	7	8	9	10	11
1. Snapper (Lutjanidae)		+	+	-	-	-	-	0	+	0	0
2. Emperors (Lethrinidae)			+	-	-	0	-	0	+	-	0
3. Groupers (Serranidae)				-	-	0	-	0	+	0	0
4. Mackerels (Scombridae)					+	+	+	0	+	0	0
5. Tunas (Scombridae)						+	+	0	+	0	0
6. Barracudas (Sphyraenidae)							+	0	+	0	0
7. Cobias (Rachycentridae)								0	+	+	+
8. Jacks (Carangidae)									+	0	0
9. Sharks (Elasmobranchii)										+	+
10. Sea catfishes (Ariidae)											+
11. Grunts (Haemulidae)											

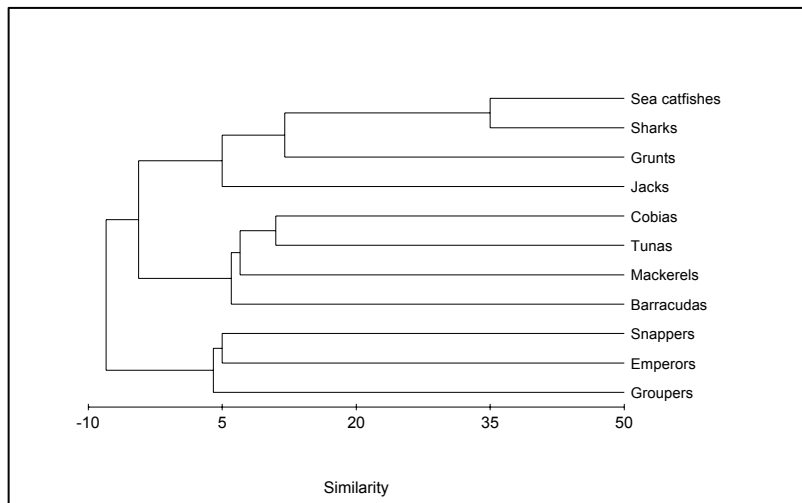

Figure 4. Categorization of the different families in the catches using cluster analysis based on their degree of co-occurrence.

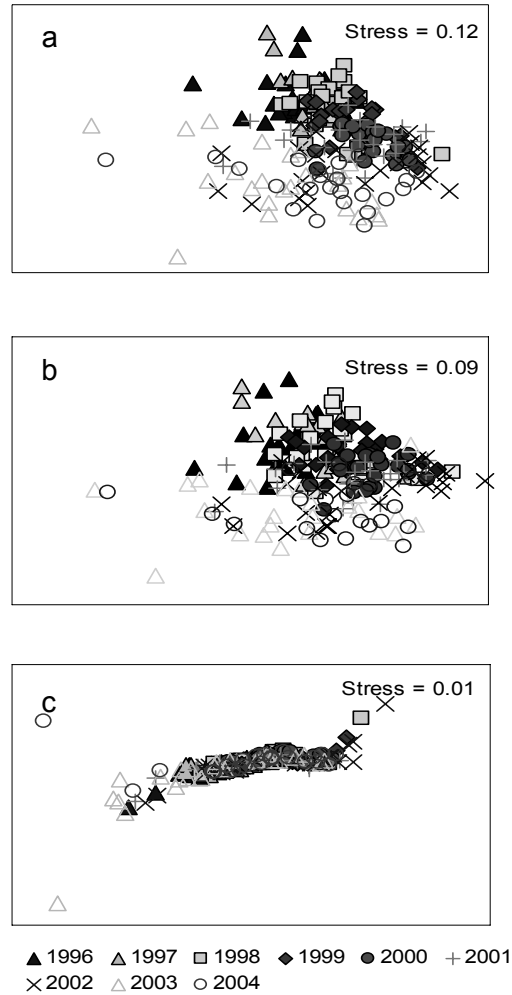

Figure 5. NMDS plots of monthly catch rates for the years 1996–2004 based on Bray-Curtis similarities before (a) and after aggregation of catch rates into three ecological categories (b) and aggregation into total catch rates (c).

NMDS ordinations showed that the multivariate pattern in catch rates did not change considerably upon aggregation of family catch data into the three ecological categories (Fig. 5a,b), as indicated by the high correlation between the Bray-Curtis similarity matrices ($r = 0.92$; $P < 0.01$) (Table 2). By contrast, the NMDS ordination pattern was altered drastically when catch data were aggregated across all families (Fig 5), suggesting a considerable loss of multivariate information.

Table 2. Pair-wise Spearman rank correlations between Bray-Curtis similarity matrices of monthly catch rates at different aggregation levels using data from 1997 and 1996–2002.

	Family	Category	Total
1997			
Species	0.98	0.96	0.68
Family		0.98	0.72
Category			0.72
1996 – 2002			
Family		0.92	0.59
Category			0.71

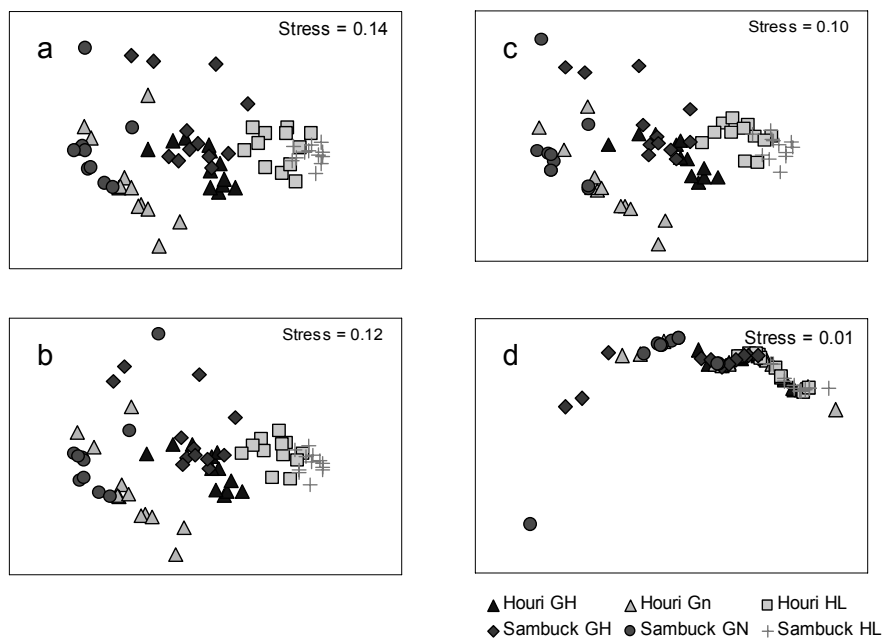

Figure 6. NMDS plots of monthly catch rates for 1997 based on Bray-Curtis similarities at four levels of aggregation, including species (a), family (b), ecological categories (c) and total catch rates (d) across the six boat-gear combinations. GH: Gillnet-Hook and line; GN: Gillnet; HL: Hook and line.

NMDS ordinations of catch rates for the year 1997 showed that the multivariate pattern at family level closely matches the one at species level. Bray-Curtis similarity matrices were highly correlated ($r = 0.98$; $P < 0.01$), indicating that catch rates at family level do not obscure actual patterns in catch rates of individual species (Fig. 6a,b; Table 2). In addition, the multivariate pattern in catch rates was not altered when data were aggregated into the three ecological categories defined above (Fig. 6c). By contrast, when species catch data were aggregated into total catch, the ordination pattern was distorted considerably ($r = 0.68$) (Fig. 6d; Table 2).

3.2. Improvements in statistical power

The number of years of data required to detect trends as statistically significant (at $\alpha = \beta = 0.1$) varied among families depending on their b/s (Table 3; Fig. 7). The b/s ranged from 0.12 for the emperors to 1.84 for jacks. Given seven years of data (1996–2002), trends in catch rate were found to be statistically significant for the jacks, sharks, sea catfishes, grunts and barracudas (Table 3). These trends were all detectable as statistically significant with 4 to 5 years of data. The number of years of data required to detect trends for the remaining families is shown as a function of the CV of the residuals in Fig. 7. Trends could be detected as statistically significant with seven years of data provided that the $b/s > 0.48$. The power to detect trends in abundance is generally expected to be lower for rare species than for common species due to higher inter-annual variability (e.g. Maxwell and Jennings, 2005). The higher statistical power for such rare fishes as sea catfishes was due to a rapid increase in their catch rate over the years (i.e. a large slope), rather than due to a lower inter-annual variability (Fig. 7).

The trends in catch rate of the most heavily fished demersal fishes, i.e. snappers, emperors and groupers, were not significant at family level (Table 3). A downward trend became significant only after the catch rates were aggregated into one category as reef-associated demersals. Indeed, the inter-annual variability in catch rates was lower after aggregation of catch data (Table 3). By contrast, the trends for near-reef pelagics were mostly positive whereas those for the open-water pelagics were not significant. Trends became more significant after aggregation of their catch rates ($b = 0.02, 0.07$, respectively) (Table 3).

Table 3. Power and trend analysis of catch rates of individual families and ecological categories (1996–2002), showing GM: geometric mean catch rate (kg-trip⁻¹); b: slope of the linear trend of log-transformed values; s: standard deviation of the residuals; b/s: trend-to-noise ratio; n: number of years of data needed to detect the trend b^{}; r²: coefficient of determination. (NS, not significant; *, significant at $\alpha < 0.05$).**

Family	Trend	GM	s	b	r ²	b/s	n
Snappers (Lutjanidae)	NS	102.3	0.07	-0.03		0.48	8
Emperors (Lethrinidae)	NS	38.9	0.06	-0.01		0.12	18
Groupers (Serranidae)	NS	58.9	0.05	-0.01		0.18	14
Reef-associated demersals	*	199.5	0.04	-0.02	0.62	0.50	7
Mackerels (Scombridae)	NS	138.0	0.04	-0.01		0.26	11
Tunas (Scombridae)	NS	40.7	0.14	0.07		0.46	8
Barracudas (Sphyraenidae)	*	24.0	0.04	0.06	0.92	1.4	4
Cobias (Rachycentridae)	NS	10.5	0.05	0.02		0.46	8
Open-water pelagics	NS	218.8	0.05	0.02	0.42	0.40	8
Jacks (Carangidae)	*	32.4	0.07	0.12	0.95	1.8	4
Sharks (Elasmobranchii)	*	22.4	0.09	-0.08	0.82	0.89	5
Sea catfishes (Ariidae)	*	20.4	0.08	0.12	0.92	1.4	4
Grunts (Haemulidae)	*	12.9	0.08	0.1	0.89	1.2	5
Near-reef pelagics	*	95.5	0.02	0.07	0.99	3.5	3

NS: non-significant; * significant at $\alpha < 0.05$; ** significant at $\alpha = \beta = 0.1$

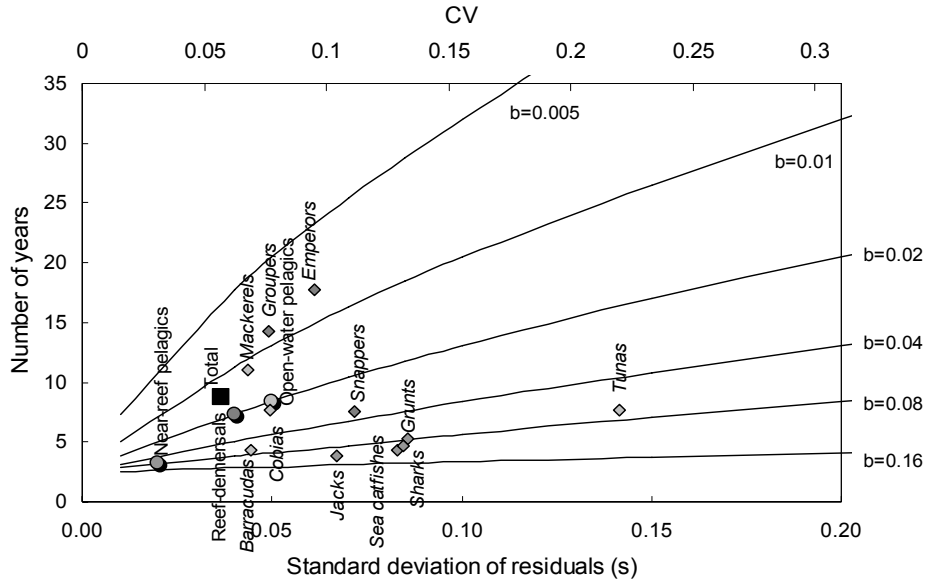

Figure 7. The number of years of data required to detect trends in catch rates of the different families and categories in relation to their respective observed annual variability (s, CV) in catch rates. Shaded data points indicate aggregated categories as used in the analysis.

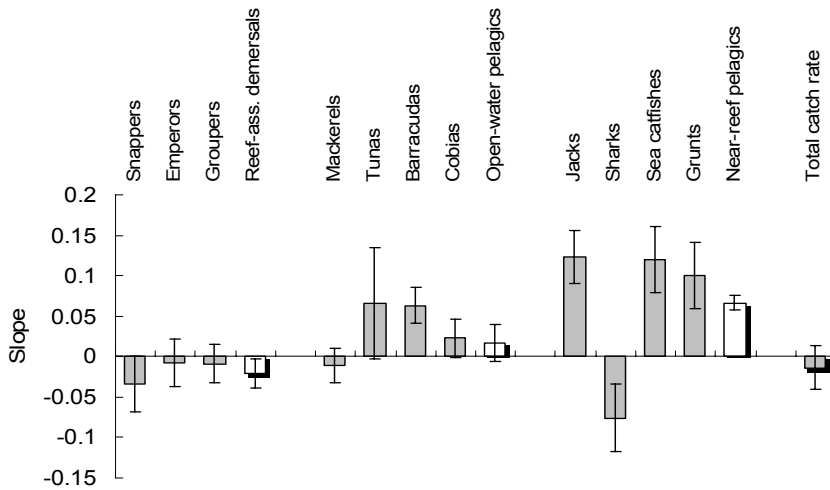

Figure 8. Trends in catch rates at family and aggregate level. The bars represent 95% confidence intervals around the slope.

Overall, aggregation of data reduced the inter-annual variability in catch rates, allowing trends to become more apparent (Fig. 8). For the near-reef pelagics, aggregation of catch rates did not only reduce inter-annual variability but also reversed the actual trend for sharks, implying that sharks could not actually be included in this category. In fact, sharks could not be placed appropriately in any one of the three categories as they exhibited significantly high degrees of co-occurrence with all families (Table 1). In addition, the positive trend for barracudas was obscured after the aggregation of the catch data into the three ecological categories.

3.3. Optimization of sampling scheme

The eleven families selected for our analysis were caught with individual variabilities of CPUE ranging from CV = 0.76 to 1.52 (Table 4). Predictably, these variabilities were all higher than that of total catch rate (CV = 0.71), implying that a sampling design at aggregate level will have lower sample size requirements. The sample size required for the estimation of annual quantities of catch in a simple random sampling was estimated at 155 (Table 5).

Table 4. The families that make up >95% of the catch in the artisanal landings, with descriptive statistics of their catch rates (CPUE) derived from non-zero catches.

Family	Occurrence (<i>p</i>)	Mean (kg·trip ⁻¹)	% of total catch	CV
Snappers (Lutjanidae)	0.80	267	30.42	0.76
Mackerels (Scombridae)	0.50	295	20.94	0.86
Groupers (Serranidae)	0.83	124	14.65	0.83
Emperors (Lethrinidae)	0.79	103	11.52	0.97
Jacks (Carangidae)	0.62	104	9.16	1.52
Tunas (Scombridae)	0.19	200	5.38	1.16
Barracudas (Sphyraenidae)	0.56	57	4.49	1.20
Sea catfishes (Ariidae)	0.10	76	1.13	1.09
Sharks (Carcharinidae)	0.11	65	1.05	1.06
Grunts (Haemulidae)	0.17	35	0.84	1.02
Cobias (Rachycentridae)	0.16	19	0.42	0.76
Total		683		0.71

Analysis of variance showed significant differences in catch rates between the six boat–gear combinations ($F_{(5,1069)} = 65.3$; $p < 0.001$). These combinations were therefore used as strata in the formulation of a stratified random sampling design. The overall mean CPUE was estimated at $682.5 \text{ kg}\cdot\text{trip}^{-1}$ (Table 5). After the removal of gear and boat effects, the variability in overall CPUE was $CV = 0.71$. For the different boat–gear combinations, the sample size requirements for the estimation of mean annual CPUE in a stratified random sampling with an *mre* of 10% ranged from $n_{\text{CPUE}} = 5\text{--}42$, which add up to a total of 127 samples per year (Table 5). Thus, compared with a simple random sampling design, the application of a stratified random sampling design would result in a reduction of ca. 20% (from 155 to 127; Fig. 9) in the number of samples required for the estimation of mean annual CPUE.

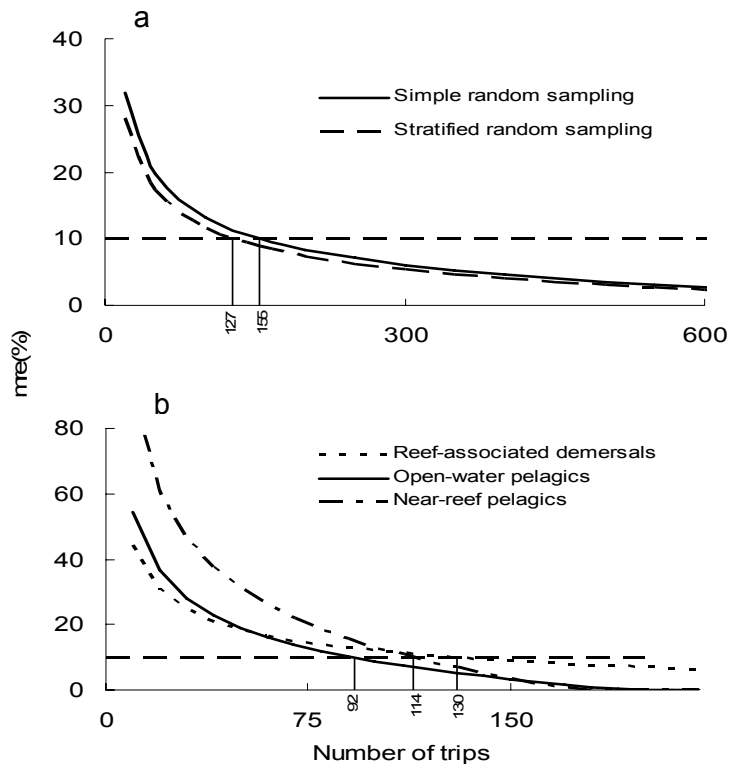

Figure 9. Sample size requirements for various levels of *mre* in the estimation of overall CPUE and total annual catch (assuming total enumeration of effort) in a simple and stratified random sampling (a) and in the estimation of CPUE for the three categories (b). The broken horizontal line represents the sample sizes required for the estimation of CPUE with an *mre* of 10%.

The total number of fishing operations in the artisanal fisheries was about 1100 trips per year. A two-week period was selected as the shortest possible time interval that results in an approximately normal distribution of the number of trips per time over the years (Tsehaye et al., 2007). The mean annual effort in number of trips per two-week time period was estimated to be 44.6, with $CV = 0.40$. Given this variability, the number of two-week periods required to attain an *mre* of 10% in the estimation of effort was estimated at 14, which is equivalent to an enumeration of fishing trips for about half a year. By combining the minimum number of samples for the estimation of CPUE and effort with an *mre* of 10%, total annual catch could be estimated with an *mre* of 14%. On the other hand, by combining a sampling design that allows for an estimation of mean annual CPUE with an *mre* of 10% with a total enumeration of effort ($CV_f = 0$), which is in fact less labour-intensive than recording catches, the total annual catch can be estimated with the same *mre* (10%) as the CPUE.

Table 5. Sample size requirements (n) for the estimation of annual catch rate (CPUE), effort(f) and total catch (C) with maximum relative error of 10% under a stratified and simple random sampling schemes given the mean and coefficient of variation (CV) of CPUE ($\text{kg}\cdot\text{trip}^{-1}$) and effort in number of trips per two-week time interval; n_c is calculated assuming total enumeration of effort, hence $n_c = n_{\text{CPUE}}$.

Boat	Gear**	CPUE	CV_{CPUE}	f	CV_f	n_{CPUE}	n_f	$n_c = n_{\text{CPUE}}$ *
Houri	All	635.7	0.81			95		
	Gh	667.6	0.54			21		
	Gn	601.1	1.09			42		
	Hl	639.0	0.77			32		
Sambuck	All	748.1	0.58			32		
	Gh	896.1	0.57			8		
	Gn	742.8	0.70			5		
	Hl	712.2	0.54			19		
Total stratified	All	682.5	0.65	44.6	0.40	127	14	127
Simple Random	All	682.5	0.71	44.6	0.40	155	14	155

* n_c is calculated assuming total enumeration of effort, hence $n_c = n_{\text{CPUE}}$

** All: catches of all gears combined; Gh catches of trips using gillnets and hook and line combined; Gn: catches from trips with only gillnets; Hl: catches from trips with only hook and line

Yet, since total catch rate was ruled out as an appropriate indicator of trends in the fish community, the sample size requirements for an effective sampling program should be determined at a lower level of aggregation (Table 6). The disaggregation of total catch rate into different categories resulted in higher sample size requirements for an optimal sampling design, owing to the higher variability at lower level of aggregation. The changes in random variability upon disaggregation of total catch data into three categories are shown in Table 4 and 6. A sample size of 336 per year was required for the estimation of annual catch rates with an *mre* of just 10% (Table 6). Assuming an average of 3.2 fishing trips per day, the required sample can be collected in 105 days, which is equivalent to a reduction of ca. 70% compared to the present total enumeration system (ca. 1100 trips per year). A sample-based scheme would therefore permit re-allocation of existing sampling resources, allowing the collection of a wider range of data.

Table 6. Sample size requirements (n) for the estimation of mean annual CPUE, effort and total catch (C) with maximum relative error of 10% in a stratified random sampling after aggregation of catches into three categories, given the mean and coefficient of variance of CPUE (kg-trip⁻¹) and effort (f).

Category	CPUE*	CV _{CPUE}	f	CV _f	n _{CPUE}	n _f	n _C = n _{CPUE} **
Reef-associated							
demersals	513.0	0.72			130		
Open-water pelagics	583.0	0.93			92		
Near-reef pelagics	146.9	1.57			114		
Total			44.6	0.40	336	14	336

* These mean CPUE estimates were based on a subset of the catch data that were considered relevant for a given category, and thus are higher than the estimates in Table 3, which were based on the entire data set.

**n_C is calculated assuming a complete enumeration of effort, hence n_C = n_{CPUE}.

4. Discussion

In many tropical fisheries, the data available to monitor fish stocks do not meet the minimum threshold required to deliver reliable conclusions, because they usually comprise of only catch and effort statistics, excluding other biologically important data (Parma and Orensanz, 2004). This study shows that in contrast to a sampling program based on a total enumeration of catch and effort data, an optimal sampling design can allow a more effective monitoring of fisheries, while permitting the collection of a wider range of data for fish stock assessment (Peterson and Rabeni, 1995; Stamatopoulos, 2002). More specifically, our analysis demonstrates that the effectiveness of a sample-based monitoring

of trends in multispecies fisheries can be improved through aggregation of catch data into fewer ecological categories.

In many fisheries, trends in catch rate of individual species are often blurred by high temporal variability (Anderson et al., 1997; van Oostenbrugge et al., 2002). By contrast, aggregation of catch data can result in a considerable reduction in inter-annual variability, thereby improving the statistical power to detect trends in catch rates. The effect of aggregation on variability is considered to be analogous to the “portfolio effect” of investment diversification in economics, whereby a diverse array of variables produces a more stable trajectory over time (Doak et al., 1998; Lehman and Tilman, 2000). Nevertheless, aggregation of catch data across all species may however obscure trends in the abundance of individual species, as total catch rate often tends to remain constant despite varying trends in the abundance of these species (Doak et al., 1998; van Oostenbrugge et al., 2002). Therefore, the choice of an appropriate level of aggregation for monitoring purposes should be made in light of the trade-offs between reducing random variability to achieve higher statistical power (through aggregation) on the one hand, and making an accurate depiction of temporal patterns in catch rates (through disaggregation) on the other.

For the Eritrean artisanal fisheries, aggregation of catch data across all species was found to obscure true trends in the catch rates of individual species, attesting to an underlying heterogeneity in species’ responses to fishing. Generally, aggregation of the catch rates of species with potentially varying responses to fishing is not advisable as it is likely to dampen or even reverse true trends in the catch rate of individual species, potentially leading to spurious conclusions concerning the state of fish stocks (Pet-Soede et al., 1999; van Oostenbrugge et al., 2002). Thus, an accurate depiction of temporal patterns in catch rates could only be made for such fisheries by aggregating multispecies catch data into more homogenous categories.

In this study, the different species or families could be divided into three distinct categories based on their degree of co-occurrence in the catch. Indeed, categorization of fishes based only on the degree of co-occurrence of species does not necessarily give rise to ecologically homogenous species categories. This is because even species with divergent life-history traits might possibly exhibit a high degree of co-occurrence in the catch depending on the multiplicity and selectivity of fishing gears used. In that case, categorization of fishes based only on degree of co-occurrence will lead to the formation of ecologically heterogeneous

categories, and trends in aggregate catch rates of such categories cannot be appropriately translated into a meaningful management strategy (Pet-Soede et al., 1999). For the artisanal fisheries of Eritrea, the target species were actually not found to have contrasting life histories, apparently relieving us of the need to account for variations in life-history traits in the categorization of the fishes. In these fisheries, the catches are mainly composed of long-lived, high trophic level piscivorous species, with relatively low intrinsic rate of population growth.

The degree of co-occurrence of species in the catch depends on interactions among species and between species and their environment at the scale of operation of the fishery (Oostenbrugge et al., 2002). In other words, if the environment at the scale of operation of the fishery is highly structured, governing the spatial distribution of species, species that exhibit a low degree of co-occurrence in the catches are likely to have originated from different fish assemblages (van Oostenbrugge, 2002). Therefore, categorization of fishes based on their degree of co-occurrence in the catch is likely to reflect an actual ecological divide, allowing valid assessment and monitoring of a suite of species as a single entity. Thus, to achieve the goals of fisheries management it is important to identify species assemblages and their spatial and temporal characteristics and to understand the conditions under which they are consistently caught together (Lee and Sampson, 2000).

Once the different families in the artisanal fisheries were divided into three categories, analysis of trends could be appropriately made at aggregate level. This was also verified by the analysis using NMDS. Accordingly, the trends in catch rates of individual families were found to be similar to those of their respective categories. This was actually with the exception of the trend in catch rate of sharks, which was reversed upon aggregation of the catch data of the near-reef pelagics. This indicates that sharks do not actually respond to fishing in the same way as the other families in this category. In fact, sharks could not be exclusively placed in any one of the three categories, as they exhibited significantly high degrees of co-occurrence with all the families in the three categories, suggesting that sharks straddle habitat boundaries among these categories. This underlines the need to consider sharks at species level, as they could probably represent more localized assemblages at species level than at family level. In addition, sharks might have a distinct life history (e.g. a very low fecundity), which probably could not be well represented by the three life-history attributes – maximum length, intrinsic growth rate and trophic level – alone, underlying their exceptional responses to fishing. These results suggest that it would be inappropriate to predict fishing responses without accounting for a wider range of life-

history attributes of the species investigated. Yet, predictions of differential responses of species to exploitation may appropriately be made based on few life-history attributes provided that these species investigated are phylogenetically related (Jennings et al., 1999a,b). In such cases, it is important to identify phylogenetically independent life-history attributes among related species in order to link varying fishing responses to life histories (Jennings et al., 1999a).

The reduction in inter-annual variability upon aggregation of catch data has important consequences for the statistical power of monitoring programs in multispecies fisheries, as it improves our ability to separate the “signal” of an impact from the “noise” of environmental or other factors (Cliff, 1987; Nagelkerke and van Densen, 2007). For the multispecies fisheries of Eritrea, aggregation of catch data into three distinct ecological categories was found to improve the statistical power to detect overall trends without a considerable loss of information on trends in the catch rates of individual species. More importantly, aggregation of catch rate data improved the statistical power in the analysis of trends in catch rate of the more vulnerable reef-associated demersals, which was otherwise inconclusive at family level. Indeed, improving statistical power through aggregation of data is particularly important if the management of vulnerable fish stocks requires evidence of highly significant declines (Maxwell and Jennings, 2005).

Our results are in agreement with findings from studies on effects of human disturbance on benthic communities suggesting that aggregation of data into bigger categories acts to dampen the effects of natural environmental variability, allowing anthropogenic impacts to become more apparent (Warwick, 1993). The reduction in variability upon aggregation of catch rates suggests the importance of compensatory feedback mechanisms, whereby species within each category make up for one another’s fluctuations, producing a more stable trajectory over time (Mcgrady-Steed and Morin, 2000; Carr et al., 2002). Similarly, it also suggests that the species within each category play complementary functional roles in sustaining fisheries yield (Doak et al., 1998; Worm et al., 2006).

The higher statistical power upon aggregation suggests that the effects of fishing become more striking at higher levels of aggregation. It also implies that fishing affects fish populations more as assemblages than as single species. Thus, trends in aggregate catch rates can provide better insights into ecosystem-level responses to fisheries than single species assessments, allowing us to see the forest for the trees (Lorenzen et al., 2006). Moreover, aggregate catch rates can be related more directly to production and socio-

economic benefits derived from fisheries (Lorenzen et al., 2006). Furthermore, analysis of aggregate catch rates can play a supplementary role in monitoring fishery trends using biological indicators, such as the mean trophic level, mean body size of fish in landings, the slope of biomass size spectra etc. (Pauly et al., 1998; Welcomme, 1999).

Finally, the reduction in variability upon aggregation of catch data has important consequences for the optimization of the CEDRS in the artisanal fisheries. Sample size requirements for the estimation of annual quantities of catch and effort were reduced considerably after aggregation of catch rates. The reduction in sample size requirements upon aggregation of catch rates thus permits the reallocation of sampling resources, allowing the collection of a wider range of fisheries data. Finally, our results underline that judicious use of available information in data-limited fisheries can provide useful indications on the status of fisheries, notwithstanding the various limitations in the collection of data from multispecies and multigear fisheries.

Acknowledgements

We would like to thank the Research and Statistics Division of the Ministry of Fisheries, Eritrea for providing us with the catch and effort data and for their helpful discussion. We are also grateful to Prof. John Videler and Prof. Johan Verreth whose comments on the initial manuscript improved the quality of this work. This study was supported by the Netherlands Organization for International Cooperation in Higher Education (Nuffic).

References

- Aitchison, J. & Brown, J.A.C., 1957. The lognormal distribution: with special reference to its use in econometrics, Monographs. Department of Applied Economics, University of Cambridge Press, Cambridge, UK, 167 pp.
- Anderson, P.J., Blackburn, J.E. & Johnson, B. A., 1997. Declines of forage species in the Gulf of Alaska, 1972–1995, as indicators of regime shift. Proceedings of the International Symposium on the Role of Forage Fishes in Marine Ecosystems (ed B. S. Baxter), pp. 531–543. Anchorage, Alaska.
- Carr, M.H., Anderson, T.W. & Hixon, M.A., 2002. Biodiversity, population regulation, and the stability of coral-reef fish communities. Proceedings of the National Academy of Sciences 99, 11241–11245.

- Clark, K.R., & Warwick, R.M., 2001. *Changes in Marine Communities: An approach to statistical analysis and interpretation*, 2nd ed. PRIMER-E Ltd., Plymouth.
- Cliff, N., 1987. *Analyzing multivariate data*. Harcourt Brace Jovanovich Inc, San Diego, 494 pp.
- Cochran, W.G., 1977. *Sampling Techniques*. John Wiley, New York, 429 pp.
- Doak, D.F., Bigger, D., Harding-Smith E., Marvier, M.A., O'Malley, R. & Thomson, D., 1998. The statistical inevitability of stability-diversity relationships in community ecology. *American Naturalist*, 151, 264–276.
- Froese, R. & Pauly, D., 2007. FishBase. World Wide Web electronic publication. www.fishbase.org, version (06/2007).
- Fryer, R.J. & Nicholson, M.D., 1993. The power of a temporal trend monitoring programme to detect linear trends and incidents. *ICES Journal of Marine Science*, 50, 161–168.
- Halls, A.S., Welcomme, R.L. & Burn, R.W., 2006. The relationship between multispecies catch and effort: among fishery comparisons. *Fisheries Research*, 77, 78–83.
- Hilborn, R. & Walters, C.J., 1992. *Quantitative fisheries stock assessment – choice dynamics and uncertainty*. Chapman & Hall, New York, 570 pp.
- Jennings, S. & Lock, J.M., 1996. Population and ecosystem effects of reef fishing. Reef fisheries (eds Paulin, N.V.C. & Roberts, C.M.), pp. 193–218. Chapman & Hall, London.
- Jennings, S., Greenstreet, S.P.R. & Reynolds, J.D., 1999a. Structural change in an exploited fish community: a consequence of differential fishing effects on species with contrasting life histories. *Journal of Animal Ecology*, 68, 617–627.
- Jennings S., Reynolds, J.D., & Polunin, V.C., 1999b. Predicting the vulnerability of tropical reef fishes to exploitation with phylogenies and life histories. *Conservation Biology*, 13, 1466–1475.
- Larkin, P.A., 1982. Directions for future research in tropical multi-species fisheries. Theory and management of tropical fisheries (eds Pauly, D., & Murphy, G.I.), pp. 309–328 ICLARM, Manila.
- Lee, Y.W. & Sampson, D.B., 2000. Spatial and Temporal Stability of Commercial Groundfish Assemblages off Oregon and Washington as Inferred from Oregon Trawl Logbooks. *Canadian Journal of Fisheries and Aquatic Sciences*, 57, 2443–2454.
- Lehman, C.L. & Tilman, D., 2000. Biodiversity, stability and productivity in competitive communities. *American Naturalist*, 156, 534–552.
- Lorenzen, K., Almeida, O., Arthur, R., Garaway, C. & Khoa, S.N., 2006. Aggregated yield and fishing effort in multispecies fisheries: an empirical analysis. *Canadian Journal of Fisheries and Aquatic Sciences*, 63, 1334–1343.
- Maxwell, D. & Jennings, S., 2005. Power of monitoring programs to detect decline and recovery of rare and vulnerable fish. *Journal of Applied Ecology*, 42, 25–37.

- McGrady-Steed, J. & Morin, P.J., 2000. Biodiversity, density compensation, and the dynamics of populations and functional groups. *Ecology*, 81, 361–373.
- Mood, A. M., Graybill, F. A. & Boes, D. C., 1974. *Introduction to the Theory of Statistics*. McGraw-Hill, 564 pp.
- Nagelkerke, L.A.J. & van Densen, W.L.T., 2007. Serial correlation and inter-annual variability in relation to the statistical power of monitoring schemes to detect trends in fish populations. *Environmental Monitoring and Assessment*, 125, 247–256.
- Parma, A. M. & Orensanz, J.M., 2004. Match and mismatch between management goals, operational guidelines and data requirements. Abstracts, Fourth World Fisheries Congress. Vancouver, Canada.
- Pauly, D., Christensen, V., Dalsegaard, J., Froese, R. & Torres, F., 1998. Fishing down marine food webs. *Science*, 279, 860–863.
- Pet-Soede, L., Machiels, M.A.M., Stam, M.A. & van Densen, W.L.T., 1999. Trends in an Indonesian coastal fishery based on catch and effort statistics and implications for the perception of the state of the stocks by fisheries officials. *Fisheries Research*, 42, 41–56.
- Peterman, R.M., 1990. Statistical power analysis can improve fisheries research and management. *Canadian Journal of Fisheries and Aquatic Sciences*, 47, 2–15.
- Peterson, J. T. & Rabeni, C.F., 1995. Optimizing sampling for stream fish communities: North American Journal of Fisheries Management. 15, 528–541.
- Sadovy, Y., 2005. Trouble on the reef: the imperative for managing vulnerable and valuable fisheries. *Fish and Fisheries*, 6, 167–185.
- SAS Institute Inc., 1999. SAS/STAT[®] Users Guide. Version 9. SAS Institute Inc., Cary, N.C.
- Snedecor, G. W. & Cochran, W. G., 1989. *Statistical Methods*. 8th ed. Iowa State University Press, Ames, 503 pp.
- Sokal, R.R. & Rohlf, F.J., 1995. *Biometry: the principles and practice of statistics in biological research*. Freeman, New York, 887 pp.
- Sparre, P., & Venema, S.C., 1998. Introduction to tropical fish stock assessment, Part 1, manual. FAO Fisheries Technical Paper, No. 306.1, Rev. 2. FAO, Rome, 407 pp.
- Stamatopolous, C., 2002. Sample-based fishery surveys – A technical handbook. FAO Fisheries Technical Paper, No. 425. FAO, Rome, 132 pp.
- Tsehaye, I., Machiels, M.A.M., & Nagelkerke, L.A.J., 2007. Rapid shifts in catch composition in the artisanal Red Sea reef fisheries of Eritrea. *Fisheries Research*, 86, 58–68.
- van Oostenbrugge, J.A.E., Bakker, E.J, van Densen, W.L.T., Machiels, M.A.M & van Zwieten, P.A.M., 2002. Characterizing catch variability in a multispecies fishery: implications for fishery management. *Canadian Journal of Fisheries and Aquatic Sciences*, 59, 1032–1043.

- van Zwieten, P.A.M., Roest, F.C., Machiels, M.A.M. & van Densen, W.L.T., 2002. Effects of interannual variability, seasonality and persistence on the perception of long-term trends in catch rates of the industrial pelagic purse-seine fishery of northern Lake Tanganyika (Burundi). *Fisheries Research*, 54, 329–348.
- Vasconcellos, M. & Cochrane, K., 2005. Overview of world status of data-limited fisheries: Inferences from landing statistics. *Fisheries Assessment in Data-Limited Situations*. (eds Kruse, G.H., Gallucci, V.F., Hay, D.E., Perry, R.I., Peterman, R.M., Shirley, T.C., Spencer, P.D., Wilson, B., & Woodby, D.), pp 1–20. Fairbanks, Alaska.
- Welcomme, R. L., 1999. A review of a model for qualitative evaluation of exploitation levels in multispecies fisheries. *Fisheries Management and Ecology*, 6, 1–19.
- Worm, B., Barbier, E. B., Beaumont, N., Duffy, E., Folke, C., Halpern, B. S. et al., 2006. Impacts of biodiversity loss on ocean ecosystem services. *Science*, 314, 787–790.
- Warwick, R.M., 1993. Environmental impact studies on marine communities: pragmatical considerations. *Australian Journal of Ecology*, 18, 63–80.

Appendix

Data on three life-history traits for the species in the catch, including maximum length (L_{max}), intrinsic rate of population increase (r , year⁻¹) and trophic level (TL).

Species	Common name	L_{max}	r	TL
Ariidae				
<i>Arius thalassinus</i>	Giant Catfish	185	1.04	3.1
Carangidae				
<i>Alepes djedaba</i>	Shrimp scad	40	4.2	3.3
<i>Carangoides bajad</i>	Orangespotted trevally	55	2.12	4.5
<i>Carangoides caeruleopinnatus</i>	Coastal trevally	40	2.82	4.4
<i>Carangoides ferdau</i>	Blue trevally	70	1.6	4.5
<i>Carangoides fulvoguttatus</i>	Yellowspotted trevally	120	NA	4.4
<i>Caranx ignobilis</i>	Giant trevally	170	0.68	4.2
<i>Caranx sexfasciatis</i>	Bigeye trevally	120	1.7	4.5
<i>Carangoides uii</i>	Onion trevally	40	2.82	4.4
<i>Scomberoides commersonianus</i>	Talang queenfish	120	1.02	4.5
<i>Scomberoides lysan</i>	Doublespotted queenfish	110	1.3	4.5
Carcharinidae				
<i>Carcharhinus melanopterus</i>	Blacktip reef shark	200	0.64	3.9
<i>Carcharhinus limbatus</i>	Blacktip shark	275	1.04	4.2
Haemulidae				
<i>Diagramma pictum</i>	Painted sweetlips	100	1.54	3.5
<i>Plectorhinchus gibbosus</i>	Harry hotlips	75	1.56	3.6
<i>Plectorhinchus schotaf</i>	Minstrel sweetlip	80	1.16	NA
<i>Pomadasys argenteus</i>	Silver grunt	70	3.14	3.4
Lethrinidae				
<i>Gymnocranius griseus</i>	Grey large-eye bream	35	2.4	3.2
<i>Lethrinus elongatus</i>	Longface emperor	80	1.56	3.8

Appendix (continued)

Species	Common name	L _{max}	r	TL
<i>Lethrinus lentjan</i>	Redspot emperor	52	3.1	4.2
<i>Lethrinus mahsena</i>	Mahsena emperor	65	1.28	3.4
<i>Lethrinus mahsenoides</i>	Saburbir emperor	52	3.1	4.2
<i>Lethrinus nebulosus</i>	Spangled emperor	87	1.46	3.3
<i>Lethrinus variegatus</i>	Slender emperor	20	4.2	3.8
<i>Lethrinus xanthochilus</i>	Yellowlip emperor	70	1.2	3.7
Lutjanidae				
<i>Pristipomoides multidens</i>	Goldband jobfish	90	1.68	3.8
<i>Lutjanus argentimaculatus</i>	Mangrove red snapper	150	1.32	3.6
<i>Lutjanus bohar</i>	Two-spot red snapper	90	2.24	4.1
<i>Lutjanus coeruleolineatus</i>	Blueline snapper	40	2.64	NA
<i>Lutjanus coccineus</i>	Humphead snapper	50	3.04	3.6
<i>Lutjanus ehrenbergi</i>	Ehrenberg's snapper	35	2.98	4.4
<i>Lutjanus fulviflammus</i>	Blackspot snapper	35	2.56	3.8
<i>Lutjanus gibbus</i>	Humpback red snapper	50	3.04	3.6
<i>Lutjanus kasmira</i>	Common bluestripe snapper	40	1.78	3.6
<i>Lutjanus malabaricus</i>	Malabar blood snapper	100	1.24	4.5
<i>Lutjanus monostigmus</i>	Onespot snapper	60	2.04	4.3
<i>Lutjanus rivulatus</i>	Blubberlip snapper	80	1.7	4.1
<i>Lutjanus sebae</i>	Emperor red snapper	116	1.28	4.3
<i>Macolor niger</i>	Black and white snapper	75	1.46	4
Rachycentridae				
<i>Rachycentron canadum</i>	Cobia	200	0.74	4
Scombridae				
<i>Grammatorcynus bilineatus</i>	Double-lined mackerel	100	NA	4.2
<i>Rastrelliger kanagurta</i>	Indian mackerel	35	5.04	3.2
<i>Scomberomorus commerson</i>	Narrowbarred Spanish mackerel	240	1.36	4.5
<i>Euthynnus affinis</i>	Kawakawa	100	2.04	4.5
<i>Thunnus tonggol</i>	Longtail tuna	145	1.76	4.5
Serranidae				
<i>Aethaloperca rogae</i>	Red mouth grouper	60	1.52	4.2
<i>Cephalopholis argus</i>	Peacock hind	60	1.62	4.5
<i>Cephalopholis miniata</i>	Coral hind	45	1.42	4.4
<i>Cephalopholis sexmaculata</i>	Six blotch hind	50	1.74	4.5
<i>Epinephelus areolatus</i>	Areolated grouper	47	2.44	3.6
<i>Epinephelus chlorostigma</i>	Brown spotted grouper	75	1.78	4
<i>Epinephelus fuscoguttatus</i>	Brown-marbled grouper	120	1.56	4.1
<i>Epinephelus malabaricus</i>	Malabar grouper	234	0.42	3.8
<i>Epinephelus polyphemadion</i>	Camouflage grouper	90	NA	3.9
<i>Epinephelus summana</i>	Summana grouper	52	1.66	NA
<i>Epinephelus tauvina</i>	Greasy grouper	75	1.08	4.1
<i>Epinephelus tukula</i>	Potato grouper	200	0.5	4.2
<i>Plectropomus maculatus</i>	Spotted coral trout	100	1.52	4.1
Sphyraenidae				
<i>Sphyraena barracuda</i>	Great barracuda	200	0.64	4.5
<i>Sphyraena forsteri</i>	Bigeye barracuda	75	1.54	4.3
<i>Sphyraena jello</i>	Pickhandle barracuda	150	0.86	4.5
<i>Sphyraena putnamiae</i>	Saw tooth barracuda	90	1.9	4.5

NA = not available; Source: Froese and Pauly (2007)

CHAPTER 5

Exploring optimal fishing scenarios for the multispecies artisanal fisheries of Eritrea using a trophic model

Iyob Tschaye^{1,2}, and Leopold A.J. Nagelkerke¹

¹*Aquaculture and Fisheries Group, Wageningen University, Wageningen Institute of Animal Sciences, Marijkeweg 40, 6709 PG Wageningen, the Netherlands.*

²*Department of Marine Sciences, University of Asmara, P.O. Box 1220, Asmara, Eritrea*

Abstract

This study represents the first attempt to assess the potential for fisheries in the artisanal Red Sea reef fisheries of Eritrea in an ecosystem context. We used an Ecopath with Ecosim model to integrate known aspects of the ecosystem and its inhabitants into a single framework, with the aim to gain a better insight into the structure and functioning of the ecosystem and to assess the impacts of fishing in these data-limited fisheries. Model outputs indicate that most of the primary productivity in the system is recycled through a detritus-based food web, implying a bottom-up energy flow control. Ecotrophic efficiencies were nevertheless higher at higher trophic levels, suggesting that top-down control mechanisms are also ecologically important. Notwithstanding a high degree of primary productivity, the fishery yields estimated for the coral reef ecosystem were relatively low, apparently because of lower ecotrophic efficiencies at the lower trophic levels. A retrospective simulation of trends in these fisheries using Ecosim showed that, given the existing fishing intensity as suggested by official statistics ($0.114 \text{ tonnes}\cdot\text{km}^{-2}\cdot\text{year}^{-1}$), a fishery-induced decline in yield (hence catch rate) of reef-associated demersals of the magnitude (ca. 25%) implied by a previous study are unlikely. However, the decline in yield observed in these fisheries could be reproduced in the simulation when the existing fishing level was assumed to be fivefold the official estimate, as suggested by anecdotal evidence on unreported catches. The simulation results show that an optimal fishing strategy could be achieved through a slight reduction in the annual catch of reef-associated fish (to $0.32 \text{ tonnes}\cdot\text{km}^{-2}\cdot\text{year}^{-1}$) and an increase in the capture of near-reef pelagics and large pelagics (to 0.19, and $0.39 \text{ tonnes}\cdot\text{km}^{-2}\cdot\text{year}^{-1}$, respectively) from the putative levels of fishing. We explored these optimal fishing scenarios in view of both direct effects of fishing on target species and indirect effects of fishing on non-target organisms. Finally, this study demonstrates that, even if modeling is no substitute for rigorous assessment of individual fish stocks with more detailed data, it could improve our understanding of the impacts of fishing on the structure and functioning of coral reef ecosystems in such newly developing fisheries, particularly on groups that would otherwise be hard to monitor.

Keywords: data-limited, multispecies fisheries, Ecopath, Ecosim, Eritrea, Red Sea

1. Introduction

The Red Sea is known for its highly diverse coral reef ecosystems, which provide a variety of ecosystem services including fisheries (Sheppard et al., 1992). The fisheries resources in the coral reefs and adjacent areas on the Eritrean Red Sea coast have been exploited almost exclusively by artisanal fisheries. The artisanal fisheries of Eritrea were launched into a renewed development in 1991 after a decades-long standstill, which was caused by the country's war for independence (Reynolds et al., 1993). The maximum sustainable yield (MSY) for the entire Eritrean Red Sea was estimated, rather roughly, to be between 36,000–79,500 tonnes·year⁻¹, 10–20% of which apparently forms the resource-base for the artisanal fisheries (Sanders and Morgan, 1989; Tsehaye et al., 2007). Indeed, only few studies have yet attempted to investigate the potential for fisheries and the impacts of artisanal fisheries on marine ecosystems in the Eritrean Red sea, much less on coral reef ecosystems (Tsehaye et. al, 2007).

The artisanal fisheries are nonetheless believed to have remained under-developed since they were launched in 1991. The total annual catch reported for these fisheries has been less than 10% of the potential sustainable yield, with annual quantities rarely exceeding 1000 tonnes·year⁻¹ (Ministry of Fisheries, 2002; this study). Thus, the effects of the artisanal fisheries on fish community structure in particular and the ecosystem as a whole were considered negligible. Nevertheless, these fisheries have been expanding over the years and total annual catch has been increasing (Tsehaye et al., 2007). In addition, although apparently limited, fishing effort is concentrated on commercially more important species of fish, with potentially more serious consequences for the ecosystem. Moreover, anecdotal evidence suggests that large amounts of unreported catches are taken illegally to Yemen, where fish apparently fetch better prices than in Eritrea. These catches are believed to be between two thirds to three quarters of the total annual catch in the artisanal fisheries (Moussalli and Haile, 2001). When these amounts are taken into account, the potential impacts of fishing on marine ecosystems could be much higher than is implied by official statistics.

Just as in many exploited reef fisheries elsewhere, the expansion of artisanal fisheries in Eritrea has also been accompanied by shifts in catch composition, with the proportion of higher-value demersal fishes declining over the years (Tsehaye et al., 2007). The changes in catch rate in these fisheries could not be explained by changes in gear or boat used or by

changes in spatial allocation of effort, making it unlikely that they were caused by changes in fishing strategies. Rather, the shifts in catch composition in these fisheries were interpreted as possibly reflecting a shift in the underlying fish community structure (Tsehaye et al., 2007). In addition, the varying trends in the CPUE of the different fish categories in these fisheries were suggested as reflecting varying levels of fishing pressure these fishes were subjected to. These scenarios imply that the existing patterns of exploitation may be unsustainable, underlining the need to evaluate the sustainability of existing fishing practices.

Given the high species diversity and multiplicity of fishing gear and craft, an effective assessment of reef fisheries requires a wide range of information on the structure and functioning of reef fish assemblages. However, just as in most multispecies, multigear fisheries in the developing world (Larkin, 1996; Bundy and Pauly, 2001), only limited research has been conducted thus far to assess the state of fish stocks in Eritrea, rendering the fisheries data-limited. The paucity of data in these fisheries precludes the application of traditional assessment methods, which are often applied in temperate fisheries (Magnusson, 1995; Sparre, 1991). In such a data-limited situation, the use of methods that are less parameter intensive is the most viable option for evaluating the status of fisheries and exploring optimal fisheries management scenarios (Bundy and Pauly, 2001).

The mass-balance ecosystem model Ecopath with Ecosim can be used to explore optimal harvesting strategies by examining the ecosystem effects of fishing (Christensen and Pauly, 1992; Pauly et al., 2000; Christensen and Walters, 2004). This approach has relatively limited data requirements, yet provides an ecological perspective for the assessment and management of multispecies, multigear fisheries. Generally, modeling can enhance our understanding of the state of fisheries and its potential influence on groups for which accurate data might be hard to come by (Pinnegar and Polunin, 2004). An evaluation of fisheries management decisions from a community or ecological viewpoint is also considered to be essential for the long-term success of fisheries, given the importance of species interactions and interactions of species with their environment (Christensen and Pauly, 2004; Fayram et al., 2006).

In this study, we used an Ecopath with Ecosim model to explore retrospectively whether the existing fishing level as suggested by official statistics and/or anecdotes could possibly be sustained by the production rate of the reef fish assemblages. We also examine if trends in catch rate derived from official catch and effort statistics could be reproduced in an

Ecosim simulation. Furthermore, we explore possible changes in target and non-target organisms in response to increased fishing effort as a way of fishing policy exploration. Meanwhile, we investigate the relative effects of the different kinds of gear on the different fish categories, since the different types of gear are considered to have varying impacts on the fish community.

2. Materials and methods

2.1. Study area

The model constructed in this study represents the coral reef and adjacent areas on the Eritrean Red Sea coast, covering an area of about 6,000 km². Eritrea has a coastline of approximately 1,720 km along the Red Sea, about 1,155 km of which lies along the continental shore, and about 565 km around some 350 islands (Fig. 1). Most of the coral reefs are concentrated around the islands in the Dahlak archipelago, a group of more than 200 islands scattered from 20–160 km off Eritrea's main port of Massawa. The shelf area around the Dahlak archipelago represents about 25% of Eritrea's total continental shelf area of 56,000 km². About 20% of the total shelf area, where most of the artisanal fisheries take place, is less than 30 m deep (Guidicelli, 1984). The total area covered by coral reefs along the Eritrean coast is about 3,260 km² (Spalding et al., 2001).

Having very high surface temperatures coupled with high salinities, the Red Sea is one of the hottest and most saline water bodies in the world. The average surface water temperature of the Red Sea during the summer is about 26°C in the north and 30°C in the south, with only about 2°C variation during the winter months (Edwards, 1987). Monthly mean temperatures on the inshore reefs near Massawa vary between 27.7 °C in January and 33 °C in August (Ateweberhan, 2004). The seasonal variation in environmental conditions, in the Southern Red sea in particular, is mainly driven by the Indian Ocean monsoon system. The year-round high temperature in the Red Sea results in the formation of a permanent thermocline, inhibiting recirculation of nutrients from the bottom of the sea to surface layers, and thereby lowering primary productivity (Edwards, 1987).

The coral reefs in the Red Sea are nevertheless known for their diverse array of fish and invertebrate populations, providing home for over 1000 species of fish and over 200 species of corals (Ormond and Edwards, 1987). The high biodiversity in this sea is also reflected in the species composition of the catches in the artisanal fisheries (Ghebremichael and Haile,

2006). According to SeaWiFS¹ global primary productivity estimates, the Red Sea is generally a moderately productive ($150\text{--}300\text{ gC}\cdot\text{m}^{-2}\cdot\text{yr}^{-1}$) ecosystem. The southern part of the Red Sea is particularly more productive due to the advection of nutrient-rich waters through Bab El Mandab, driven by the monsoon winds (Beckmann, 1984; Sheppard et al., 1992; Veldhuis et al., 1997; Getahun, 1998). This part of the Red Sea is also known for its wide continental shelf, which is dotted by a large number of low-lying coralline islands (Reynolds, et al., 1993).

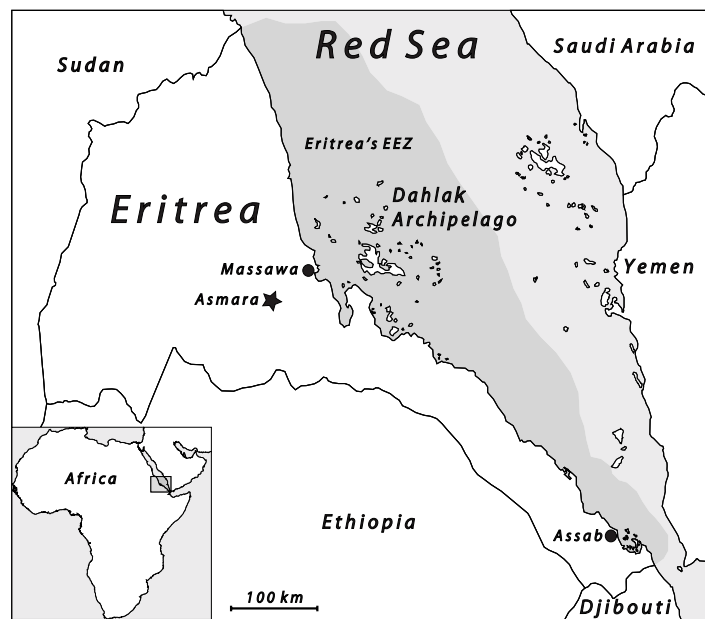

Figure 1. Map of the Red Sea off the coast of Eritrea showing the areas for which the model was constructed.

The coral reefs on Eritrea's Red Sea coast are mostly of the fringing reef type, forming borders along the shoreline and surrounding islands. Such reef formations extend along the entire length of the Eritrean Red Sea. These reef formations are nevertheless mostly patchy and lack well-defined zonation patterns, a characteristic feature typical of the southern Red Sea coral reefs. This is due apparently to the shallow and gently sloping continental shelf and stronger water currents, which mainly constrain the growth of reef forming corals (Hillman and Tsegay, 1997). By contrast, the coral reefs of the northern and central Red

¹ <http://oceancolor.gsfc.nasa.gov/SeaWiFS/>

Sea are well developed, having more distinct zones of reef flat, reef crest and reef slope (Sheppard et al., 1992). In addition, the coral reefs in the northern and central Red Sea extend to a depth of about 40 m, whereas the southern Red Sea reefs are usually less than 10 m deep, owing to the variation in shore profile between the northern and southern Red Sea (Roberts et al., 1992). Accordingly, the species diversity of corals and fish in the Red Sea tends to decrease from the north toward the south (Sheppard and Sheppard, 1991; Sheppard et al., 1992).

2.2. The model

We constructed a mass-balance ecosystem model to describe the structure and functioning of the coral reef and adjacent ecosystems off Eritrea's Red Sea coast using Ecopath (Fig. 2). Ecopath is a steady state mass-balance representation of trophic interactions, used to describe and examine the energy flows in ecosystems, providing insight into ecosystem structure and functioning. This modeling approach is based on a set of simultaneous linear equations for each functional group (state variable) considered in the system, where the production of a given group is equal to the sum of all predations, non-predatory losses and exports (Christensen et al., 2000). The basic equation for each functional group is given as:

Production by (i) = all predation on (i) + non-predation losses of (i) + catch (i) + export of (i)

or

$$B_i \left(\frac{P}{B_i} \right) = \sum_j B_j \left(\frac{Q}{B_j} \right) DC_{ji} + \left(\frac{P}{B_i} \right) B_i (1 - EE_i) + EX_i$$

where B_i = biomass (tonnes·km⁻²) of functional group (i), P/B_i = production/biomass of (i), EE_i = ecotrophic efficiency of (i), (i.e., the proportion of the production that is exported or consumed by the predators in the system), Q/B_j = consumption/biomass ratio of (i), B_j = biomass (tonnes·km⁻²) of predator (j) DC_{ji} = fraction of prey (i) in the average diet of predator (j), and EX_i = export or catch of (i) (Christensen and Pauly, 1992).

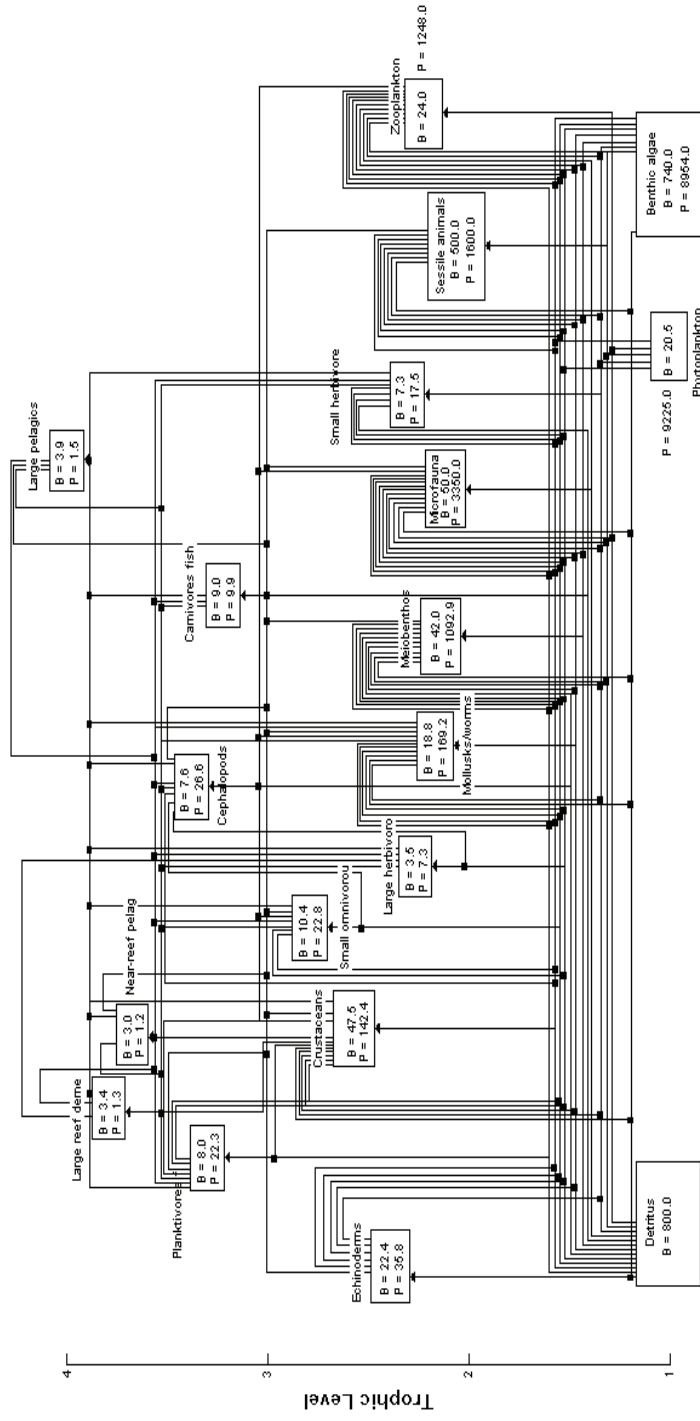

Figure 2. Flows of biomass for the mass-balance ecosystem model of the Red Sea, Eritrea. All biomasses are in tonnes·km⁻² and production in tonnes·km⁻²·year⁻¹. → flow; ■ connector.

Each functional group in the model is represented by one balanced equation and requires at least five input parameters. Export and diet composition of each group are mandatory, and three of the four parameters, B , P/B , Q/B , and EE , must be entered for each group. The linear equations are then solved and the unknown parameters are estimated. The most robust approach is to enter B , P/B and Q/B and allow the model to estimate EE . This provides a check for the mass balance because EE cannot be greater than 1. Sometimes, it is necessary to enter EE , in which case a default of 0.95 is used (Christensen and Pauly, 1992).

The Ecopath mass-balance results are used as input data for a trophodynamic simulation model, Ecosim. Ecosim is based on a series of coupled differential equations to describe the changes in biomass and flow within the system over time by accounting for changes in predation, consumption rate and fishing (Christensen and Walters, 2004). The rate of change of biomass of group i (B_i) is given as:

$$\frac{dB_i}{dt} = g_i \sum_j Q_{ji} - \sum_j Q_{ij} + I_j - (m_i + F_i + e_i)B_i$$

Where g_i is the net growth efficiency; Q_{ji} and Q_{ij} are the consumption rate of group j by group i and the consumption rate of group i by group j , respectively; I_j is the immigration flow in tonnes·km⁻²; m_i is non-predation mortality; F_i is fishing mortality; and e_i is emigration rate (Christensen and Walters, 2004).

2.3. Input parameters

Our Ecopath model was initialized in 1998. The model was constructed based on 19 functional groups in total, including detritus; benthic algae; phytoplankton; zooplankton; seven groups of invertebrates (comprising sessile animals, decomposers, meiobenthos, macrobenthos, crustaceans, echinoderms and cephalopods) and eight groups of fish (including planktivorous fishes, small herbivorous reef fishes, large herbivorous reef fishes, carnivorous fishes, large pelagics, near-reef pelagics and large reef demersals) (Table 1).

Detritus represents the pool for dead organic material, including particulate and dissolved organic matter. Detritus standing stock was estimated as a function of primary production (PP , in g C·m⁻²·year⁻²) and euphotic depth (E , in m) using an empirical equation (Pauly et al., 1993):

$$\log_{10} D = -2.41 + 0.954 \log_{10} PP + 0.863 \log_{10} E$$

Table 1. Input data and resulting parameters, including biomass (tonnes·km⁻²), P/B (year⁻¹), Q/B (year⁻¹), EE, system omnivory index (SOI) and catch (tonnes·km⁻²) for the 19 functional groups of the Ecopath model of the southern Red Sea.

Functional group	TL	B	P/B	Q/B	EE	SOI	Catch
Large reef demersals	3.79	3.40	0.37	3.9	0.77	0.215	0.11
Near-reef pelagics	3.67	3.00	0.39	4.5	0.68	0.267	0.02
Large pelagics	4	3.90	0.38	4.9	0.73	0.180	0.06
Carnivorous fish	3.22	9.00	1.1	6	0.69	0.249	
Large herbivorous reef fish	2.27	3.45	2.1	20	0.82	0.284	
Small omnivorous reef fish	2.79	10.38	2.2	18	0.83	0.499	
Small herbivorous reef fish	2.3	7.30	2.4	32	0.84	0.300	
Planktivorous fishes	3.3	7.95	2.8	15	0.91	0.062	
Cephalopods	3.38	7.61	3.5	12	0.79	0.288	
Echinoderms	2.39	22.35	1.6	8	0.82	0.313	
Crustaceans	2.57	47.48	3	10	0.84	0.380	
Mollusks/worms	2.17	18.80	9	30	0.65	0.169	
Meiobenthos	2.14	42.04	26	100	0.44	0.142	
Decomposers/microfauna	2.12	50	67	219	0.48	0.124	
Sessile animals	2.06	500	3.2	12	0.11	0.063	
Zooplankton	2.22	24	52	178	0.77	0.200	
Phytoplankton	1	20.5	450	–	0.27	0.000	
Benthic algae	1	740	12.1	–	0.09	0.000	
Detritus	1	800	–	–	0.998	0.273	

Values calculated by EwE are shown in bold.

The level of primary production (*PP*) was estimated as the sum of the primary production of phytoplankton and macroalgae. The average euphotic depth for the southern Red Sea was estimated to be 40.5m (Department of Marine Sciences, University of Asmara, Asmara, Eritrea, 1999; unpublished data)². Primary producers were grouped into phytoplankton and benthic algae. Phytoplankton biomass was calculated as the average of the estimates by Veldhuis et al. (1997) and Department of Marine Sciences (unpublished data). The biomass estimates for benthic algae, which mainly comprised of fleshy

² Department of Marine Sciences (1999). Available at the Department of Marine Sciences Library, P.O.Box 1220, Asmara, Eritrea

macrophytes, turf algae and crustose corallines, was taken from Ateweberhan (2004). The biomass estimate for zooplankton was obtained from data in Van Couwelaar (1997). The functional group “sessile animals” represented mainly sponges, sea anemones, scleractinian coral and tunicates. The most common reef forming genera in this part of the Red Sea are *Porites*, *Sytopora*, *Montipora*, *Ehinopora* and *Platygyra*, with the percentage of live coral cover ranging from 30–70% (Zekeria and Videler, 2000). Biomass of sessile animals was calculated based on data from the Research and Training Division, Ministry of Fisheries,³ Zekeria (2003), Ateweberhan (2004) and Department of Marine Sciences (1999, 2000⁴ and 2005⁵; unpublished data).

The functional group “decomposers/microfauna” mainly represented benthic and pelagic bacteria populations and foraminiferans. The meiobenthos mainly comprised of polychaetes and nematods. All mollusks and worm-like animals were grouped as macrobenthos. The crustaceans included a wide range of taxa ranging from small-sized isopods and amphipods to large-sized shrimps, lobsters and crabs. The echinoderms represented the sea urchins, starfishes and sea cucumbers. The cephalopods included squids and octopuses. No biomass data were available for most of these invertebrate groups, however. Therefore, this problem was dealt with by allowing the model to estimate the biomasses for these groups assuming a default value of 0.95 for the EE, just as in Bundy and Pauly (2001).

The functional group “planktivorous fishes” is mainly represented by fusiliers (Caesionidae), chromis (Pomacentridae, subfamily Chrominae), soldierfishes (Holocentridae, subfamily Myripristinae), cardinal fishes (Apogonidae), and sweepers (Pempheridae). The small herbivorous reef fishes comprise of surgeonfishes (Acanthuridae) and rabbitfishes (Siganidae). Butterflyfishes (Chaetodontidae), which are mainly corallivores, angelfishes (Pomacanthidae), and damselfishes (Pomacentridae, subfamily Pomacentrinae) were grouped as “small omnivorous reef fishes”. The functional group “large herbivorous reef fishes” represented mainly parrotfishes (Scaridae). Wrasses (Labridae), grunts (Haemulidae), goatfishes (Mullidae), squirrelfishes (Holocentridae, subfamily Holocentrinae) were grouped as “carnivorous fishes”. The biomass data set for the fish groups was estimated from fish count data (including their size distribution) from

³ Ministry of Fisheries (1997). Available at the Ministry of Fisheries. P.O. Box 18, Massawa, Eritrea

⁴ Department of Marine Sciences (1999; 2000). Available at the Department of Marine Sciences Library, P.O.Box 1220, Asmara, Eritrea.

⁵ Department of Marine Sciences (2005). Available at the Department of Marine Sciences Library, P.O.Box 1220, Asmara, Eritrea.

underwater visual census (UVC) surveys carried out by the Department of Marine Sciences, University of Asmara (1999, 2000 and 2005) – in which the first author took part – and the Research and Training Division, Ministry of Fisheries (1997). These studies were carried out using 5m wide line transect, recording the fish that are readily visible within a belt of 2.5m either side of the transect line. Fish count data were converted to biomasses using length–weight relationships for the major species of fish within each functional group, which were derived from Fishbase (Froese and Pauly, 2007).

Commercially important species were considered separately in the model to ensure that the role of fisheries is represented more precisely. The functional group “large pelagics” represented mackerels, tunas (Scombridae) and barracudas (Sphyraenidae); the “near-reef pelagics” included jacks (Carangidae) and sharks (Elasmobranchii); and the “large reef demersals” comprised groupers (Serranidae), snappers (Lutjanidae) and emperors (Lethrinidae). The biomass data set for these functional groups were also reconstructed based on data from visual census studies conducted by the Department of Marine Sciences in 1999, 2000 and 2005 and the Ministry of fisheries (1997).

The P/B values for the fish functional groups were derived as a function of the von Bertalanffy growth coefficient (K), the asymptotic length (L_{inf}) and water temperature in °C (T) using the following empirical relationship (Pauly, 1980).

$$\frac{P}{B} = K^{0.65} L_{inf}^{-0.279} T^{0.463}$$

The Q/B values were estimated for each functional group using the empirical relationship of Palomares and Pauly (1998):

$$\log \frac{Q}{B} = 7.964 - 0.204 \log W_{inf} - 1.965 T + 0.083 A + 0.532 h + 0.398 d$$

Where W_{inf} is the asymptotic weight calculated from L_{inf} and length–weight relationships, T is water temperature expressed as $1000/(T (^{\circ}\text{C}) + 273.15)$, A is the aspect ratio of the caudal fin and h and d are dummy variables indicating the feeding category of the species, i.e. herbivore ($h = 1, d = 0$), detritivore ($h = 0, d = 1$) or carnivore ($h=0, d = 0$).

The P/B and Q/B values for the non-fish functional groups were derived from literature on comparative coral reef ecosystems elsewhere, such as the Caribbean, the Philippines, Mexico and the Western Indian Ocean (Opitz, 1993; Opitz, 1996; Bundy and Pauly, 2001; Durville et al., 2003; Arias-Gonzalez et al., 2004).

Data on diet composition for most of the fish groups were obtained from stomach content analysis of the major species in each group (Table 2). Diet composition data for the non-fish functional groups were derived from literature on comparative coral reef ecosystems elsewhere, including Opitz (1993), Opitz (1996), Bundy and Pauly (2001) Durville et al. (2003) and Arias-Gonzalez et al. (2004).

The fishery input parameters, including catch, fishing fleet and gear, were obtained from the catch and effort data recording system of the Eritrean Ministry of Fisheries. In the artisanal fisheries, fishing operations are mainly carried out using two types of boats: houris and sambucks. Houris are small wooden boats of 4 to 9 m in length, equipped with an out-board engine. Sambucks are 12 to 17 m wooden boats with an inboard engine. The main types of fishing gear used in these fisheries are gillnets, hook and line or a combination of both. Gillnets and hook and line are mainly used for the capture of pelagic and demersal fish, respectively. Fishers in the artisanal fisheries have varying preference for the different groups of fish, because of the varying market demands for these fishes. As a result, the catches in these fisheries are mainly made up of (a) snappers (Lutjanidae), including mainly Two-spot red snapper (*Lutjanus bohar*), Humpback red snapper (*Lutjanus gibbosus*), and Humphead snapper (*Lutjanus sanguineus*); (b) groupers (Serranidae), mainly including Brown-spotted grouper (*Epinephelus chlorostigma*), and Malabar grouper (*Epinephelus malabaricus*); (c) emperors (Lethrinidae), including Longface emperor (*Lethrinus elongatus*), and Goldband jobfish (*Pristipomoides multidens*); and (d) mackerels and tunas (Scombridae) including Narrow-barred Spanish mackerel (*Scomberomorus commerson*) and Longtail tuna (*Thunnus tonggol*) (Ghebremichael and Haile, 2006). For our present purposes, the artisanal fishery was divided into three groups based on gear type: hook and line fisheries, which mostly target the reef-associated demersals; gillnet fisheries, which are mostly employed in fishing the near-reef and large pelagics; and mixed fisheries combining both gears.

Table 2. Diet composition matrix for the different functional groups considered in the model.

Prey Functional group	Predator															
	1	2	3	4	5	6	7	8	9	10	11	12	13	14	15	16
1 Large reef demersals	0.010	0.021	0.020	0.001												
2 Near-reef pelagics	0.020	0.005	0.020	0.001												
3 Large pelagics	0.010	0.033	0.020	0.001												
4 Carnivorous fish	0.200	0.109	0.112	0.010												
5 Large herbivorous reef fish	0.130	0.130	0.098	0.011												
6 Small omnivorous reef fish	0.140	0.130	0.217	0.070	0.001	0.009		0.010								
7 Small herbivorous reef fish	0.170	0.011	0.011	0.011	0.001	0.018			0.017							
8 Planktivorous fishes	0.130	0.087	0.348	0.010	0.001	0.020		0.070								
9 Cephalopods	0.020	0.022	0.020	0.010	0.001	0.030		0.100								
10 Echinoderms				0.011	0.030	0.040	0.030			0.010	0.010	0.010				
11 Crustaceans	0.137	0.169	0.123	0.254	0.050	0.080	0.050	0.320	0.150	0.040	0.010	0.010				
12 Mollusks/worms	0.033	0.283	0.011	0.200	0.040	0.160	0.080	0.010	0.270	0.040	0.010	0.010				
13 Meiobenthos				0.140	0.020	0.050	0.020	0.060	0.100	0.080	0.200	0.040	0.060		0.010	
14 Decomposers/microfauna				0.120	0.020	0.050	0.020	0.010	0.050	0.070	0.124	0.027	0.010	0.050	0.010	0.200
15 Sessile animals				0.050	0.020	0.094	0.020			0.090	0.027	0.040	0.010		0.010	
16 Zooplankton				0.020	0.020	0.045	0.020	0.580	0.200		0.054	0.006	0.040	0.050	0.020	
17 Phytoplankton				0.030			0.010				0.060				0.050	0.500
18 Benthic algae				0.566	0.100	0.550				0.300	0.100	0.057	0.040		0.050	
19 Detritus				0.100	0.200	0.304	0.200	0.020	0.050	0.370	0.369	0.800	0.840	0.900	0.850	0.300
20 Sum	1.000	1.000	1.000	1.000	1.000	1.000	1.000	1.000	1.000	1.000	1.000	1.000	1.000	1.000	1.000	1.000

2.4. Balancing the model and temporal simulation

To achieve mass-balance in the model, we used the Autobalance routine of Ecopath, an iterative procedure whereby the biomass and diet composition data of the groups with an EE value of greater than 1 are adjusted by varying them within the confidence level of the initial input values (Kavanaugh et al. 2004). Ranges of percent uncertainty are assigned to the biomass P, B, Q/B, diet and catch input values in the Pedigree routine, specifying whether they are taken from a model of a similar system, or are based on a rough or precise estimate from local data. Thus, when seeking to reduce EE values to 1, only small changes are made to the more precise input values, whereas larger changes are made to the less precise input values. A balanced model is achieved when all groups have an EE of less than unity. For the Red sea model, the confidence intervals of the initial parameter values used in the Autobalance routine are given in Table 3. Once a mass-balance was achieved, the Ecoranger routine was used to determine the number of combinations of parameters that produce a balanced model. This routine randomly draws input parameters for each functional group in a Monte Carlo fashion from within the confidence intervals specified in the Pedigree routine of Ecopath. The number of successful runs is used as a measure of sensitivity of the model.

Once a mass-balance Ecopath model was constructed, the trophic level of each group was calculated by the model. The model was also used to calculate several network flow indices as measures of ecosystem maturity following Odum (1969). These indices calculated for the Red Sea model include the Finn's cycling index (FCI), the system omnivory index (SOI) and the connectance index (CI). Finn's cycling index (FCI) is generally a measure of recycled energy flow in a given system. More specifically, FCI is the proportion of the total system throughput attributed to the recycling of material within the system (Finn, 1976).

Subsequently, we run Ecosim to simulate temporal changes in ecosystem status as well as in fisheries yield under different fishing scenarios and different assumptions of energy flow control or vulnerability to predation. We also simulated direct and indirect effects of fishing on community structure under different harvesting scenarios. The simulations were performed under different scenarios: (1) maintaining the existing level of fishing as suggested by official statistics, i.e. fishing effort required for the capture of 0.114, 0.024, and 0.062 tonnes·km⁻²·year⁻¹ for large reef demersal fishes, near reef pelagic fishes and large pelagics, respectively at the onset fisheries; (2) assuming the existing level of fishing to be fivefold the official estimates, as suggested by anecdotal/circumstantial evidence on

unreported catches; (3) general expansion of the fisheries to a level suggested by previous studies as being required to achieve maximum sustainable yield, which was tenfold the official estimate on average (Grofit, 1971; Aubray, 1975; Gaudet, 1981; Guidicelli, 1984; Antoine et al., 1998) and (4) differential expansion of the different fisheries depending on their potential yield to achieve an optimal fishing strategy.

To select an appropriate prey vulnerability level for the system, we compared yield and biomass trajectories in Ecosim under different energy flow control scenarios with trends and biomass estimates from previous studies. This was done by altering the vulnerability rate “ v ” in Ecosim from $v = 3$ to $v = 1$ to $v = 2$, representing the predominance of top-down (Lotka-Volterra), bottom-up (donor-driven), and mixed energy flow control mechanisms, respectively.

Table 3. Pedigree ranges specifying the percent uncertainty of the different parameters in the Ecopath model of the Red Sea.

Group	Ecopath parameter				
	Biomass	P/B	Q/B	Diet	Catch
Large reef demersals	30	50	50	40	10
Near-reef pelagics	30	50	50	40	10
Large pelagics	30	50	50	40	10
Carnivorous fish	30	50	50	50	
Large herbivorous reef fish	30	50	50	40	
Small omnivorous reef fish	30	50	50	40	
Small herbivorous reef fish	30	50	50	40	
Planktivorous fishes	30	50	50	40	
Cephalopods	80	50	50	70	
Echinoderms	80	50	50	70	
Crustaceans	80	50	50	70	
Mollusks/worms	80	50	50	70	
Meiobenthos	80	50	50	70	
Decomposers/microfauna	80	50	50	70	
Sessile animals	30	50	50	70	
Zooplankton	30	50	50	70	
Phytoplankton	30				
Benthic algae	30				

3. Results

3.1. Model uncertainty

Given the confidence intervals in Table 3, the pedigree index for the Red Sea Ecopath model was estimated at 0.51 on a 0–1 scale describing how well rooted a model is in local data (Christensen et al. 2000). This is comparable with the pedigree index of Ecopath models from other studies, such as Pinnegar and Polunin (2004) and Fayram et al., (2006). Yet, this still highlights the need for more relevant data for the construction of a trophic model for the ecosystem we investigated. Indeed, higher values were registered for some Ecopath models, including Villanueva et al. (2006), where pedigree indices of 0.75–0.79 were attained. In the Ecoranger routine, we obtained an average of 21 successful runs out of a total of 10,000, with a least sum of deviation of 13.2, suggesting that the model was tightly fitted.

3.2. Structural and network analysis

The estimated biomasses, trophic level, energy budget and ecotrophic efficiencies of each group are given in Table 1. The production/consumption ratio was estimated to be between 0.05 and 0.3 and the production/respiration ratio was less than 1 for all functional groups in the model, which is in compliance with thermodynamic limits. The model estimated a high ecotrophic efficiency for higher trophic level groups, indicating that predation, rather than nutrient limitation, is the major force regulating ecosystem structure and function. On the other hand, the lower ecotrophic efficiency at lower trophic levels suggests a higher rate of organic waste at these levels. The system omnivory index (SOI) was calculated to be 0.207, indicating a low degree of omnivory in the system. The connectance index (CI), as the ratio of actual links between groups to the number of theoretically possible links, was estimated at 0.463, suggesting a high diversity of functional groups, which is typical of a system approaching maturity. In addition, the system showed a production/total respiration (P/R) ratio of 1.002, implying a high energy efficiency in the system (Table 4).

Trophic flow rates of the system are given in Table 5 and Fig. 3, which were formed by aggregating the 19 functional groups into a single linear food chain (after Ulanowicz and Puccia, 1990). The results indicate a relatively higher concentration of biomass at the lower trophic levels, with 760.5 tonnes·km⁻² at trophic level I and 666.8 tonnes·km⁻² at trophic level II. Fish groups on the other hand accounted for a small proportion of the total system

production and biomass. The total net primary production in the system was found to be 18,179 tonnes·km⁻²·year⁻¹ (Table 4), suggesting a highly productive system. The total system throughput, expressed as the sum of all consumption, exports, respiratory flows and flows to detritus, was 66,249 tonnes·km⁻²·year⁻¹, an amount comparable to what was estimated for highly productive reef or coastal systems in the Mexican Caribbean and West African coast (Arias-Gonzalez et al., 2004; Villanueva et al., 2006). The total consumption in the system was 27,443 tonnes·km⁻²·year⁻¹, about 86% of which originating from detritus rather than from primary producers. The latter resulted in a detritivory:herbivory (D:H) ratio of 6.3:1 for the system. The geometric mean transfer efficiency was 8.6% (Table 5). For this system, transfer efficiencies did not decline much at high trophic levels (Fig. 3), suggesting a higher energy efficiency at higher trophic levels.

Table 4. Summary system statistics for the Red Sea Ecopath model.

Parameter	Value
Sum of all consumption (tonnes·km ⁻² ·year ⁻¹)	27443
Sum of all exports (tonnes·km ⁻² ·year ⁻¹)	37
Sum of all respiratory flows (tonnes·km ⁻² ·year ⁻¹)	18142
Sum of all flows into detritus (tonnes·km ⁻² ·year ⁻¹)	20627
Total system throughput (tonnes·km ⁻² ·year ⁻¹)	66249
Sum of all production (tonnes·km ⁻² ·year ⁻¹)	25927
Mean trophic level of the catch	3.84
Gross efficiency (catch/net p.p.)	0.000011
Calculated total net primary production (tonnes·km ⁻² ·year ⁻¹)	18179
Total primary production/total respiration (P/R)	1.002
Net system production (tonnes·km ⁻² ·year ⁻¹)	37
Total primary production/total biomass	11.95
Total biomass/total throughput	0.023
Total biomass (excluding detritus) (tonnes·km ⁻²)	1521
Total catches (tonnes·km ⁻² ·year ⁻¹)	0.200
Connectance index (CI)	0.463
System omnivory index (SOI)	0.206

Figure 3. Schematic representation (Lindeman Spine) of trophic flow of the Red Sea coral reef model, showing functional groups aggregated into a single linear food chain.

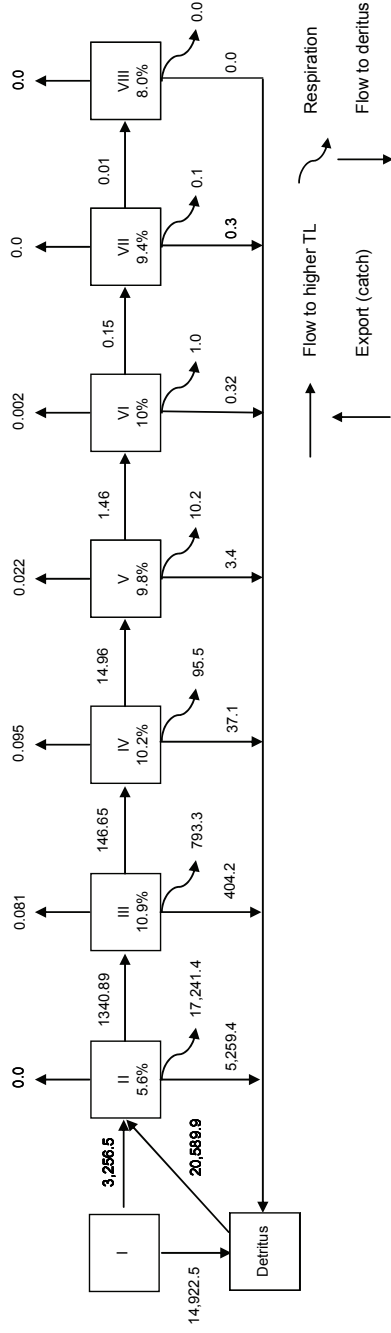

Table 5. Transfer efficiency (%) and biomass (tonnes·km⁻²) of each trophic category in the model.

Source	Trophic category								
	I	II	III	IV	V	VI	VII	VIII	Average
Producer	9.1	8.4	11.1	10.3	9.5	9.1	6.9	9.5	9.5
Detritus	5.1	11.6	10	9.7	10.1	9.4	8.2	8.4	8.4
All flows	5.6	10.9	10.2	9.8	10	9.4	8	8.6	8.6
Biomass	760.5	666.8	77.4	14.3	2.0	0.2	0.02	0.002	

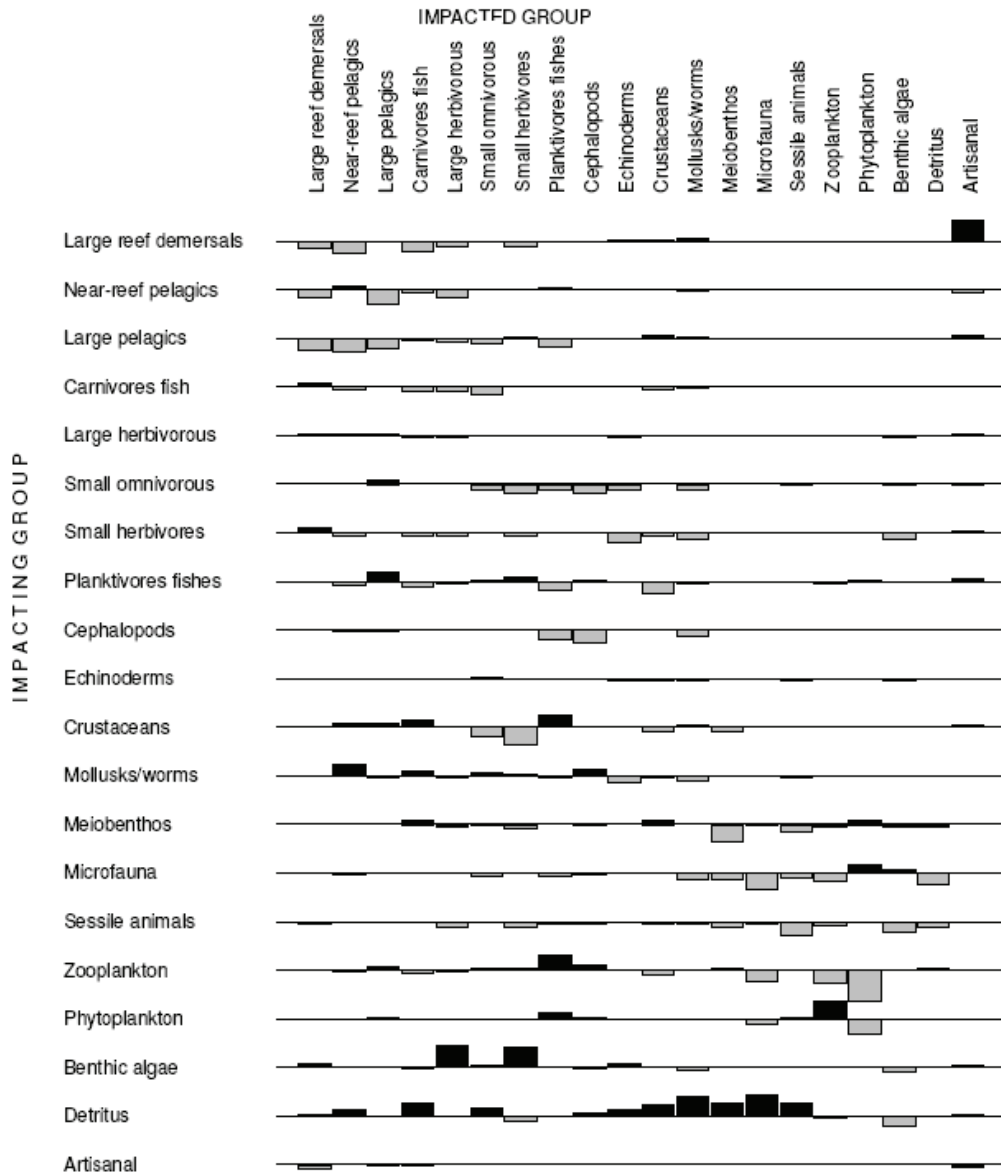

Figure 4. Mixed trophic impacts showing direct and indirect impacts of an infinitesimal increase in the biomass of each functional group on biomass of the other groups in the Ecopath model of the Red Sea. Positive impacts are shown above the line, and negative impacts below.

The matrix in Fig. 4 shows mixed trophic impacts, including direct and indirect impacts of an infinitesimal increase of the biomass of a given group on the biomass of the other groups. The mixed trophic impacts matrix does not provide strong evidence for top-down prey-predator interactions or trophic cascades. Most functional groups respond rather negatively to an increase in their own biomass, due apparently to an increase in competition within the functional group (Christensen et al., 2005). These results also show that secondary production of the system is mainly based on detritus, suggesting that all net primary production is not directly used but enters into the coral reef food chains through heterotrophic benthic organisms. This was also evident from the high level of Finn's cycling index estimated for the system (10.76 %) (Table 6). Finn's straight-through path length (with detritus) was 3.25, an amount also comparable to estimates from other reef systems (Arias-Gonzalez, 1998). Such a high Finn's straight-through path length also suggests a relatively high system maturity. On the other hand, the high rate of predatory cycling index (4.34%) suggests the importance of predation in the structure and functioning of the ecosystem at higher trophic levels.

Table 6. Network flow indices for the Ecopath model.

Parameter	Value
Throughput cycled (excluding detritus) (tonnes·km ⁻² ·year ⁻¹)	1084.34
Predatory cycling index (% of throughput w/o detritus)	4.34
Throughput cycled (including detritus) (tonnes·km ⁻² ·year ⁻¹)	7130.36
Finn's cycling index (% of total throughput)	10.76
Finn's mean path length	3.644
Finn's straight-through path length (without detritus)	1.318
Finn's straight-through path length (with detritus)	3.252
Ascendancy (A, flowbits)	76527.4
Overhead (F, flowbits)	200511.1
Capacity (C, flowbits)	277038.5
A/C	0.28

The mean trophic level of the catch was estimated to be 3.84, reflecting a fishery mainly targeting top predators. The fishery gross efficiency was 0.000011 (Table 4), suggesting that fishery could not play an important role in structuring the ecosystem. This estimate was however based only on official statistics, which are presumed to reflect fishing rates far lower than is actually harvested.

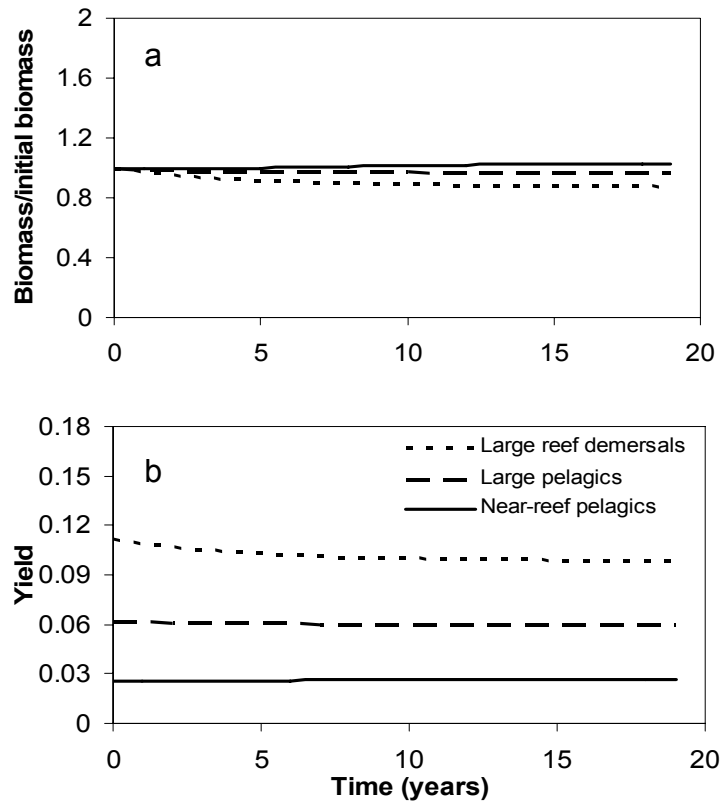

Figure 5. Simulated changes in standing biomass of fish (a) and fisheries yield (tonnes·km⁻²·year⁻¹) (b) using fishing rates suggested by official statistics.

3.3. Temporal dynamics

The steady-state yield and biomass estimations were made using Ecosim under a vulnerability value of $v = 3$, because the default Ecosim flow control or vulnerability level, $v = 2$, resulted in MSY estimates that are far too optimistic (>25% higher than the maximum MSY suggested for the coral reef ecosystem by the other studies), just as was suggested by Christensen et al. (2000). Biomasses and fisheries yield of the different functional groups were simulated over a 20-year period. Simulation of the impacts of the existing rate of fishing as suggested by official statistics – i.e. fishing effort for the capture 0.11, 0.02 and 0.06 tonnes·km⁻²·year⁻¹ for large reef demersals, near-reef pelagics and large pelagic, respectively at the onset of fisheries – on the biomass and yield of the target species is shown in Fig. 5a and b.

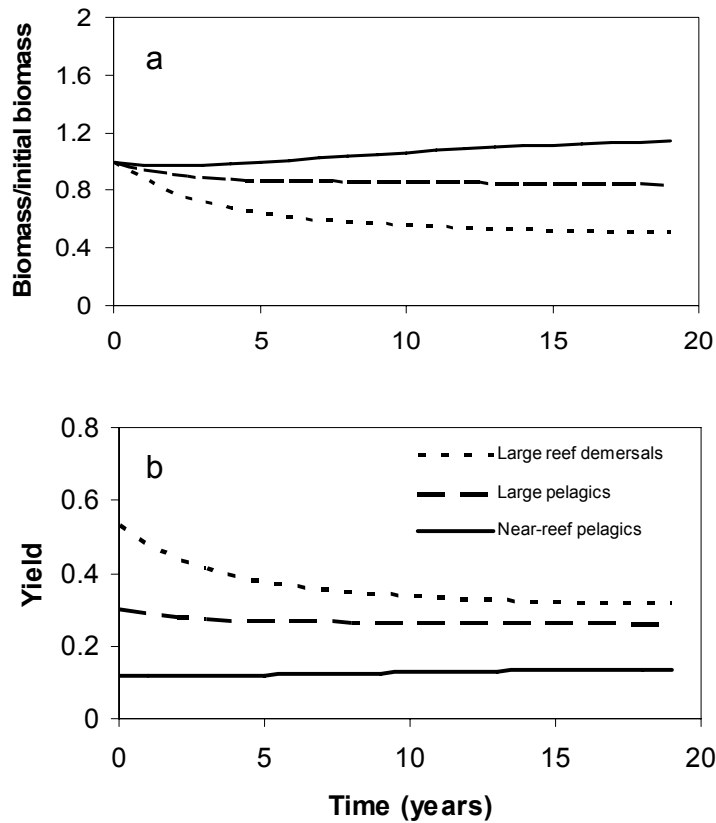

Figure 6. Simulated changes in standing biomass of fish (a) and fisheries yield (tonnes·km⁻²·year⁻¹) (b) when the existing fishing rate was assumed to be five times the official estimate, as suggested by anecdotal evidence on unreported catches.

Given the fishing intensities suggested by official statistics, the artisanal fisheries would be too small to have significant long-term consequences for sustainability of the fisheries. On the other hand, the existing level of fishing intensity as suggested by official statistics as well as anecdotal evidence on unreported catches was estimated to be fivefold the official estimate. Simulation of possible impacts of fishing at this intensity indicates that fishing would actually have long-term negative consequences for the biomass and yield of large reef demersal fishes in particular (Fig. 6a and b). In this case, most of the changes in fisheries yield would occur within the first five years, subsequently leading to the formation of a new equilibrium. By contrast, the biomass or yield of near-reef pelagics and large pelagics would not show any sign of decline in response to the increase in fishing intensity.

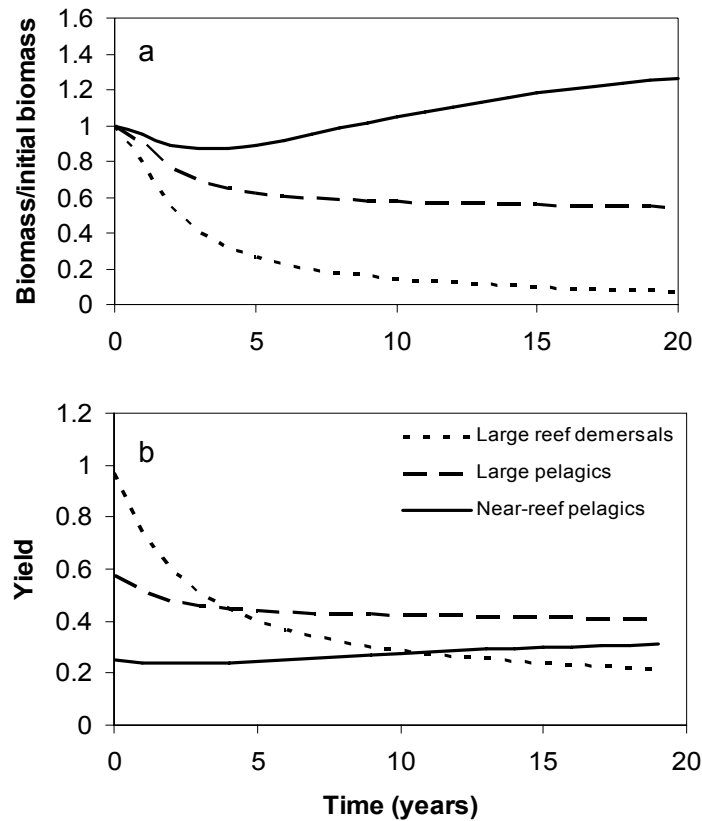

Figure 7. Simulated changes in standing biomass of fish (a) and fisheries yield (tonnes·km⁻²·year⁻¹) (b) in response to a tenfold increase in fishing rate, which was considered to be required to achieve maximum sustainable yield.

Changes in biomass and fisheries yield in response to a general increase in fishing rate were simulated over a 20-year period for all functional groups (Fig. 7a and b). A tenfold increase in fishing rate was suggested by previous studies to be required to attain maximum sustainable yield from the artisanal fisheries. However, such an increase in fishing rate would result in a decline in the biomass and yield of large reef demersal fishes, suggesting that a general increase in fishing rate would not actually allow achieving maximum sustainable harvest (Fig 6a). Here, most of the decline would also take place within the first five years, but continued up to the end of the simulation period (year 20), preventing the establishment of a new equilibrium. Simulation of the changes in standing biomass of exploited species underlying the changes in yield showed that the decline in the standing

stock of large reef demersals, following an increase in fishing rate, would lead to an increase in the standing stock of near-reef pelagics.

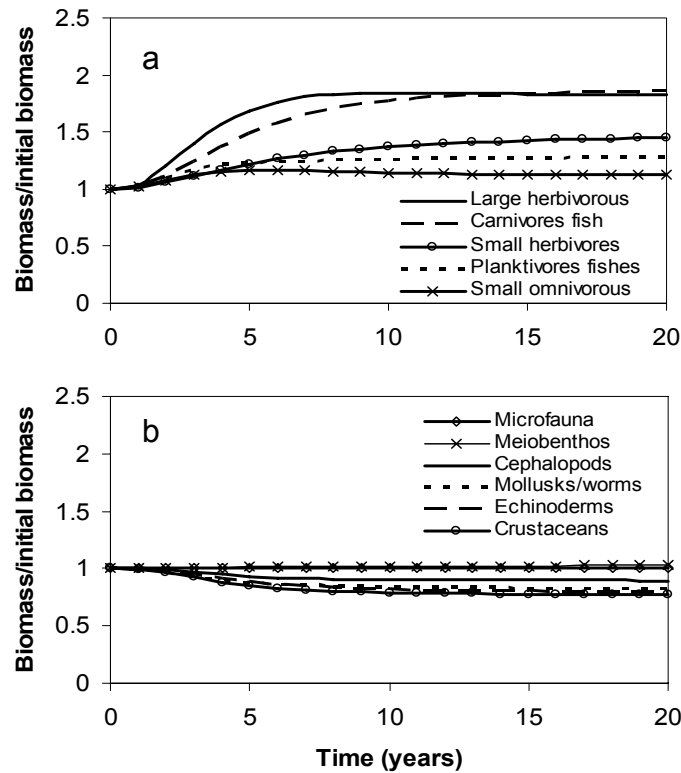

Figure 8. Indirect effects of a tenfold increase in fishing rate on fish functional groups (a) and non-fish functional groups (b) simulated over a 20-year period.

A general (tenfold) increase in fishing effort would subject the different functional groups to varying levels of fishing pressure, potentially resulting in varying trends in biomass and yield of these groups. This is mainly because some functional groups were initially subjected to lower levels of fishing pressure than others, as suggested by the official statistics. The fishing mortality rates estimated based on official statistics were 0.033, 0.0087 and 0.016 year⁻¹ for large reef demersal fishes, near reef pelagic fishes and large pelagics, respectively. Thus, the varying responses to a general increase in fishing rate do not necessarily imply varying productivities of the different functional groups, but rather varying levels of fishing pressure these groups were subjected to.

A tenfold increase in fishing pressure would also have an impact on non-target groups in the ecosystem (Fig. 8), with the changes being more pronounced on fish groups than on invertebrates. An increase in fishing pressure on piscivorous fishes would lead to an increase in the biomass of forage fish and a simultaneous decrease in the biomass of invertebrates. Most of these changes would also occur during the first 5 years, subsequently leading to the formation of a new equilibrium. By contrast, a tenfold increase in fishing rate would not have a significant effect on the standing biomasses of lower trophic level organisms, including sessile organisms, phytoplankton, benthic algae and detritus (results not shown).

Network analysis in Ecosim indicated that the increase in fishing intensity would not cause significant changes in the indices of ecosystem development, suggesting a highly stable system. Finn's cycling index, for example, was found to be 9.99 % by the end of the 20th year of simulation. The same is also evidenced by the high level of relative overhead of the system (Table 6).

3.4. Responses to varying fishing intensities

The changes in yield and standing biomass in response to varying levels of fishing rate were simulated in an attempt to determine optimal fishing strategies for the different target groups (Fig. 9). The results indicate that maximum sustainable yields of 0.32, 0.19, and 0.39 tonnes·km⁻²·year⁻¹ can be achieved at fishing mortality rates of 0.20, 0.16, and 0.25 year⁻¹ for large reef demersals, near-reef pelagics and large pelagics, respectively. This indicates that maximum sustainable yield could only be achieved with different fishing rates for the different target groups rather than with a general increase in fishing intensity. The fishing rate for maximum sustainable yield would raise the fishery gross efficiency of the system to 0.000063. A general increase in fishing rate would on the other hand lead to an over-exploitation of large reef demersals before the other groups were even fully exploited (Fig. 10), a scenario which is not desirable. The existing harvest rate of large reef associated fishes as suggested by the sum of official statistics and unreported catches was higher than the maximum sustainable yield estimated for this group, making the decline in yield suggested by the Ecosim simulation and Tsehaye et al. (2007) more likely. The existing fishing rate of near-reef pelagics and large pelagics was however lower than the maximum sustainable yield suggested for these fishes.

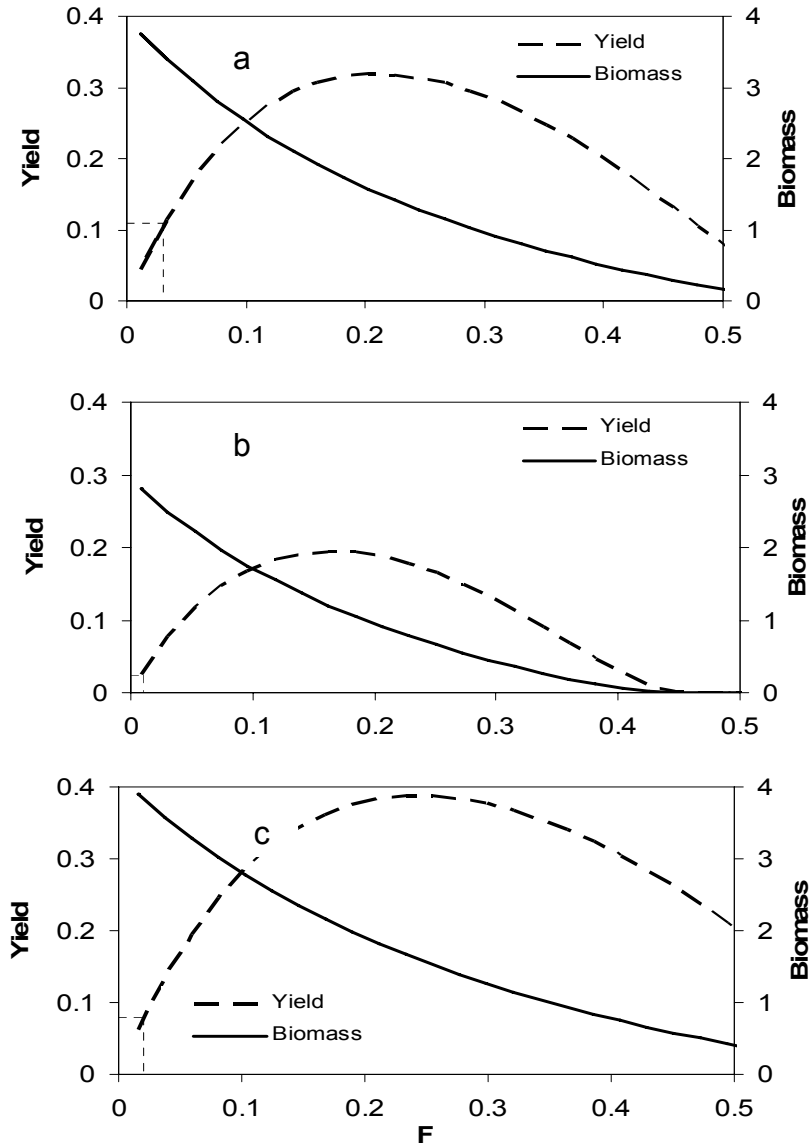

Figure 9. Simulated changes in fisheries yield and standing biomass in response to changes in fishing mortality (F) for large reef demersals (a), near-reef pelagics (b) and large pelagics (c). MSY was estimated at 0.32, 0.19, 0.39 tonnes·km⁻²·year⁻¹, and fishing mortality F_{msy} was estimated at 0.20, 0.16, 0.25 year⁻¹ for large reef demersals (a), near-reef pelagics (b) and large pelagics (c), respectively. Dotted lines represent the existing levels of fishing mortality and yield for the different functional groups as suggested by official statistics.

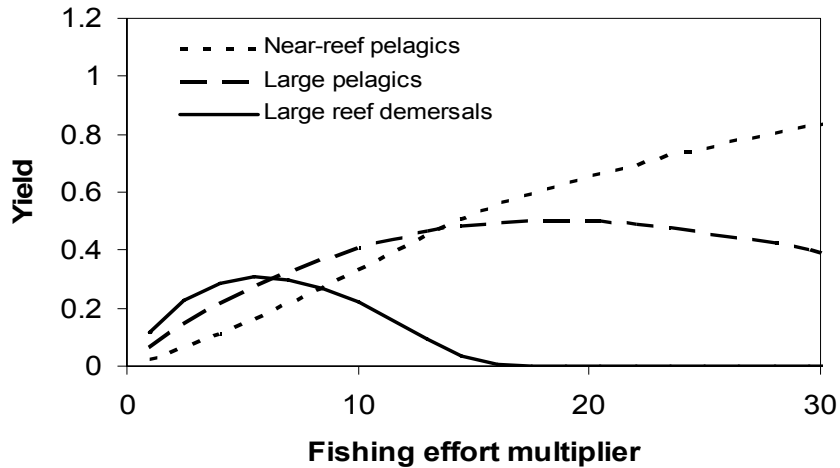

Figure 10. Effects of a general increase in fishing pressure from the official level on the yield of the different functional groups.

4. Discussion

The outputs from the mass-balance Ecopath model indicate that a large amount of material is recycled in the coral reef system on the Eritrean Red Sea coast. Most of the primary productivity is recycled in the food web through detritus-based microbial food webs, resulting in a relatively higher cycling index and longer pathways. In other words, not all net primary production is directly used but enters into the coral reef food chains through heterotrophic benthic organisms, suggesting the prevalence of bottom-up energy flow control mechanisms. On the other hand, a secondary form of recycling and a relatively short one involving predation exists at higher trophic levels, implying that top-down control mechanisms are also ecologically important in this ecosystem (Arias-Gonzalez et al., 1997). This is also evident from the higher ecotrophic efficiencies at higher trophic levels in the system. Generally, natural systems are more likely to exhibit a mixture of bottom-up and top-down control mechanisms and weak trophic links, a characteristic feature that enhances community maturity (Pinnegar and Polunin, 2004).

The fishery yield estimated by the model was rather low for an ecosystem with such a high degree of primary productivity. Indeed, the low level of fisheries yield estimated is mainly because we only considered the target species in the fisheries, which comprise of almost exclusively piscivorous fishes. Yet, the low level of yield estimated for these fishes is

apparently due to lower trophic efficiencies at the lower trophic levels. This also suggests that the majority of net primary productivity is recycled in detrital pool, with little being used by herbivores. Similar processes have been suggested for coral reef ecosystems elsewhere, such as in Tiahuta, Moorea Island and French Polynesia (Arias-Gonzalez et al., 1997). Generally, there appear to be few mechanisms for transferring primary production of benthic algae through the trophic levels of coral reef communities (Medley et al., 1993). Our results are also consistent with the results of Ateweberhan (2004) on seasonal dynamics of coral reef algae in the southern Red Sea suggesting extreme seasonality in algal productivity, with most of the production entering the detrital pool. The relatively low fishery yield despite the high rate of primary in coral reefs is also believed to be due to a higher proportion of internal predation (i.e. high ecotrophic efficiency) in the system (Polovina, 1984; Arias-Gonzalez et al., 1997).

The high rate of recycling through detrital food webs nevertheless suggests an ecosystem resistant to perturbation by fisheries or otherwise (Vasconcellos et al., 1997). The same was also evident from the rapid establishment of a new equilibrium when the system was subjected to a higher level of fishing in the Ecosim simulations. Generally, systems where bottom-up energy flow mechanisms predominate do not show dramatic changes in measures of community development in response to perturbation (Pinnegar and Polunin, 2004; Fayram et al., 2006).

Yet, coral reef fish are generally more vulnerable to overexploitation than their open-water counterparts (van Rooij et al., 1998). One of the reasons suggested for the vulnerability of coral reefs is that their productivity is highly dependent on rapid and tight recycling of nutrients. Indeed, owing to their slow growth and low fecundity, reef-associated predatory fishes, are also highly vulnerable to fishing and can exponentially decline even at the early stages in the development of fisheries. As a result, even when observed yields are much lower than the maximum sustainable yield predicted by fish production models or empirical studies, the abundance of many reef fishes could be significantly reduced by fishing (Jennings et al., 1999). This is particularly so given the highly selective nature of species targeting strategies in the artisanal fisheries in our case. Therefore, the shifts in catch composition from the higher-value demersal to the lower-value pelagic fishes, accompanying the expansion of the artisanal fisheries over the years, were to be expected (Tsehaye et al., 2007). Here, we examined using Ecosim temporal simulations if the shifts in catch composition observed in these fisheries could actually be interpreted as reflecting shifts in the underlying fish community structure. The simulation of temporal dynamics for

these fisheries revealed that, given the existing fishing intensity as suggested by official statistics, a fishery-induced decline in yield and abundance of reef-associated demersals of the magnitude (ca. 25%) suggested by Tsehaye et al. (2007) are quite unlikely. It was impossible to attribute the decline in CPUE of reef associated demersals to fishing when total catches were only about 1000 tonnes·year⁻¹. The decline in yield observed in these fisheries could however be reproduced in an Ecosim simulation when the existing fishing pressure was assumed to be five-fold the official level, as suggested by anecdotal evidence on unreported catches.

In accordance with the results from CPUE analysis in Tsehaye et al. (2007), trends in yield of near-reef pelagic fishes and large pelagic fishes did not show any sign of decline in the Ecosim simulation under either of the above scenarios. These results suggest that the potential for the expansion of the artisanal fisheries mainly lies in the stocks of near-reef pelagics fishes and large pelagic fishes. A general expansion of all fishery types, on the other hand, would result in an over-exploitation of large reef demersal fishes even before the other species are fully exploited, highlighting the need for the optimization of fish targeting strategies for these multispecies fisheries. For these fisheries, an optimal fishing strategy could be attained through a slight reduction in the capture of reef-associated fish and a simultaneous increase in the capture of near-reef pelagics and large pelagics from the putative fishing levels. By contrast, continuation of the existing trends of expansion could lead to a rapid decline in the abundance of large reef demersals, potentially leading to fishing down marine food webs (Pauly et al., 2000).

The exploration of optimal fishing scenarios ought to be made from the point of view of not only direct effects of fishing but also indirect effects of fishing on non-target species. For this purpose, Ecosim could provide a good insight into the ecosystem impacts of fisheries exploitation (Christensen et al, 2000). In our Ecosim simulations, the most rapid responses to fishing were observed among the target species, which generally exhibited an exponential decline. However, even though the increase in fishing pressure resulted in an increase in the biomass of prey fishes – due apparently to release from predation – and a subsequent decline in the biomasses of invertebrate groups, the analysis using Ecosim did not provide strong evidence for the existence of trophic cascades. Accordingly, the changes in the stocks of the currently commercially important fishes and the consequent changes in forage fish and invertebrate abundance could not have a significant effect on the coral reef ecosystem as a whole. This was also evidenced by the minimal changes in Finn's cycling over the years upon the removal of predatory fishes in the Ecosim simulations. Such

scenarios are not unlikely given the low biomass of predators exerting a top-down control on the ecosystem and the high rate of recycling in the system. In similar studies elsewhere (e.g. Mediterranean rocky littoral communities and eastern Scotian Shelf), Ecosim simulation also provided little support for ecosystem-wide effects of fishing (Pinnegar and Polunin, 2004 and Bundy, 2005).

The sustainable yield predicted by Ecosim for the artisanal fisheries as a whole might be smaller than the sum of the MSY estimates of individual fish categories estimated by previous studies, e.g. Guidicelli (1984), Reynolds et al. (1993), and Tsehaye et al., (2007). For such highly complex multispecies systems, it is generally not known whether compensatory or depensatory responses to fishing are more important, thus nor whether ecosystem-level yield estimates from models would be lower or higher than the sum of yield estimates from single-species assessments (Walters et al., 2005; Mueter and Megrey, 2006). Indeed, ecosystem modeling is not meant to give accurate estimates of yield. Rather, it is mainly designed to provide a context within which one can explore optimal fishing scenarios rather than estimate potential sustainable yields (Christensen and Pauly, 2004). Our study demonstrates that even though modeling significantly enhances our understanding of the impacts of fishing on the structure and functioning of coral reef ecosystems, particularly on groups that would otherwise be difficult to study, an ecosystem-based analysis is no substitute for single-species stock assessment. In fact, such ecosystem-based approaches often draw their input data from single-species stock assessments (Christensen and Pauly, 2004).

This study represents the first attempt to evaluate the impact of fisheries in the Red Sea in an ecosystem context using an ecosystem model. However, the inputs used in the construction of the model were rather average values for the different coral reef ecosystems along Eritrea Red Sea coast, and do not represent any specific areas. What can be achieved in modeling studies of this sort is that a large set of known aspects of the ecosystem and its inhabitants are integrated into a single framework with the aim to gain an insight into the potential impacts of fisheries at a large spatial scale, while at the same time highlighting the information gap for the study of more localized effects. The pedigree index estimated for the present model (51%) is comparable to that estimated for other models, suggesting that the present model is well founded in local data. Yet, the pedigree index still suggests a significant degree of uncertainty in the model outputs, stressing the need for more relevant or local data to achieve a more accurate representation of the ecosystem. Finally, our exploration of optimal fishing scenarios was mainly undertaken from the point of view of

an ecological goal function. A more rational management should however account for economic and social benefits within the framework of ecosystem conservation (Christensen et al., 2005; Arreguin-Sanches et al., 2004). In view of this, the present model can be extended in a subsequent work by accounting for economic and social goal functions in the exploration of optimal fishing policies for the artisanal fisheries.

Acknowledgements

We would like to thank the Research and Statistics Division of the Ministry of Fisheries, Eritrea for providing us with the catch and effort data and for their helpful discussion. We are also grateful to Dr. Villy Christensen (Fisheries Center, UBC), Ir. Paul van Zwieten, Prof. Johan Verreth (Wageningen University) and Prof. John Videler (University of Groningen) whose comments on the initial manuscript greatly improved the quality of this work. This study was supported by the Netherlands Organization for International Cooperation in Higher Education (Nuffic) as part of the MBF-UoA-MHO project.

References

- Antoine, L., Blanchard, F., Boucher, J., Massé, J., Morizur, Y., Araia, T., Mahmoud, S., Wolday, S., 1998. Assessment and follow-up of the potential of fisheries resources in Eritrea. Fisheries resources assessment project MOF-IFREMER-CFD, 24 pp+addenda.
- Afewerki, B., 2000. Socio-economic Survey of Southern Red Sea: The case of fishing villages. Ministry of Fisheries, Assab, Eritrea.
- Arias-Gonzalez, J. E., Delesalle, B., Salvat, B., Galzin, R., 1997. Trophic functioning of the Tiahura reef sector, Moorea Island, French Polynesia. *Coral Reefs* 16, 231–246.
- Arias-Gonzalez, J. E., 1998. Trophic models of protected and unprotected coral reef ecosystems in the South of the Mexican Caribbean. *J. Fish. Biol.* 53, 236–255.
- Arias-Gonzalez, J. E., Nunez-Lara, E., Gonzalez-Salas, C., Galzin, R., 2004. Trophic models for investigation of fishing effect on coral reef ecosystems. *Ecol. Model.* 172, 197–212.
- Arreguin-Sanches, F., Hernandez-Herrera, A., Ramirez-Rodriguez, M., Perez-Espana, H., 2004. Optimal management scenarios for the artisanal fisheries in the ecosystem of La Paz Bay, Baja California Sur, Mexico. *Ecol. Model.* 172, 373–382.
- Ateweberhan, M., 2004. Seasonal dynamics of coral reef algae in the southern Red Sea: functional group and population ecology. Ph.D. thesis, University of Groningen, the Netherlands, 187 pp.
- Aubray, R., 1975. The fisheries of Ethiopia. An economic study. FAO, Rome, 23 pp.

- Beckmann, W., 1984. Mesozooplankton distribution on a transect from the Gulf of Aden to the central Red Sea during the winter monsoon. *Oceanolog. Acta.* 7, 87–102.
- Bundy, A., 2005. Structure and functioning of the eastern Scotian Shelf ecosystem before and after the collapse of groundfish stocks in the early 1990's. *Can. J. Fish. Aquat. Sci.* 62, 1453–1473.
- Bundy, A., Pauly, D., 2001. Selective harvesting by small-scale fisheries: ecosystem analysis of San Miguel Bay, Philippines. *Fish. Res.* 53, 263–281.
- Christensen, V., Pauly, D. 1992, Ecopath II—a software for balancing steady-state ecosystem models and calculating network characteristics. *Ecol. Model.* 61, 169–185.
- Christensen, V., Pauly, D., 2004. Placing fisheries in their ecosystem context, an introduction. *Ecol. Model.* 172, 103–107.
- Christensen, V., Walters, C., 2004. Ecopath with Ecosim: methods, capabilities and limitations. *Ecol. Model.* 172, 109–139.
- Christensen, V., Walters, C.J., Pauly, D., 2005. Ecopath with Ecosim: A user's guide. Fisheries Centre, UBC, 130 p.
- Department of Marine Sciences, 1999. Report on the field-trip to the Howakil Archipelago. University of Asmara, Asmara, Eritrea.
- Department of Marine Sciences, 2000. Report on the Southern Red Sea Expedition. University of Asmara, Asmara, Eritrea.
- Department of Marine Sciences, 2005. Eritrean-Israeli Southern Red Sea expedition. Massawa, Eritrea.
- Durville, P., Chabanet, P., Quod, J.P., 2003. Visual Census of the reef fishes in the natural reserve of the Glorieuses Islands (Western Indian Ocean). *Western Indian Ocean J. Mar. Sci.* 2, 95–104.
- Edwards, F.J., 1987. Climate and oceanography. In: Edwards, F.J, Head, M.S. (Eds.), *Red Sea: Key Environments*. Pergamon, Oxford, pp 45–69.
- Fayram, A.H., Hansen, M.J., Ehlinger, T.J., 2006. Characterizing changes in maturity of lakes resulting from supplementation of walleye populations. *Ecol. Model.* 197, 103–115.
- Finn, J.T., 1976. Measurements of ecosystem structure and function derived from analysis of flows. *J. Theor. Biol.* 56, 363–380.
- Froese, R. & D. Pauly, 2007. FishBase. World Wide Web electronic publication. www.fishbase.org, version (06/2007).
- Gaudet, J.L., 1981. Report on mission to Ethiopia. Fisheries Policy and Planning Service files. Rome, FAO (mimeo).
- Getahun, A., 1998. The Red Sea as an extension of the Indian Ocean. In: Sherman, et al., (Eds.), *Large Marine Ecosystems of the Indian Ocean: Assessment, Sustainability, and Management*. Blackwell Science, Oxford, pp 277–283.

- Ghebremichael, A., Haile, S., 2006. Commercial fishes of the Eritrean Red Sea. Apex Publishing Ltd., Essex, England, 266 pp.
- Grofit, E., 1971. The Red Sea fisheries of Ethiopia. Centre for Agricultural Cooperation with Developing Countries, Ministry of Agriculture, Isreal, 82 pp.
- Guidicelli, M., 1984. The Ethiopian fisheries: situation, development needs and opportunities. Report prepared for the Fishery Planning and Development Project. Field Document (FI/DP/ETH/82/016). FAO, Rome, 157 pp.
- Hillman, J.C., Tsegay, S., 1997. Coral reef research and conservation in Eritrea. Paper presented to the Western Indian Ocean Regional Workshop on Coral Reef Research and Conservation. 12 pp.
- Jennings, S., Polunin, V.V.C., 1997. Impacts of predator depletion by fishing on the biomass and diversity of non-target reef fish communities. *Coral Reefs* 16, 71–82.
- Jennings, S., Reynolds, J.D., Polunin, N.V.C., 1999. Predicting the vulnerability of tropical reef fishes to exploitation with phylogenies and life histories. *Conservation Biology*, 13, 1466–1475
- Kavanaugh, P., Newlands, N., Christensen, V., Pauly, D., 2004. Automated parameter optimization for Ecopath ecosystem models. *Ecol. Model.* 172, 141–149.
- Larkin, P.A., 1996. Concepts and issues in marine ecosystem management. *Rev. Fish. Biol. Fish.* 6, 139–164.
- Magnusson, K.G., 1995. An overview of the multispecies VPA – theory and applications. *Rev. Fish Biol. Fish.* 5, 195–212.
- Medley, P.A., Gaudian, G., Wells, S., 1993. Coral reef fisheries stock assessment. *Rev. Fish Biol. Fish.* 3, 242–285.
- Ministry of Fisheries, 1997. The Marine biodiversity of Eritrea: results from the GEF-PRIF Project Expedition (1996–1997). Massawa, Eritrea, 44pp + annexes.
- Moussalli, E., Haile, T., 2001. Ex-post Evaluation of the Semhar Fisheries Rehabilitation Project ERI/92/001(UNDP) ERI/92/C01 (UNCDF) and Capacity Building for the National Marine Resources Programme ERI/94/001 (UNDP). UNDP, 53 pp.
- Mueter, F.J., Megrey, B.A., 2006. Using multispecies surplus production models to estimate ecosystem-level maximum sustainable yields. *Fish. Res.* 81, 189–201.
- Odum, E.P., 1969. The strategy of ecosystem development. *Science* 164, 262–270.
- Opitz, S., 1993. A quantitative model of the trophic interactions in a Caribbean coral reef ecosystem. In: Christensen V. and Pauly, D. (Eds.) *Trophic models of aquatic ecosystems*. ICLARM conf. Proc. 26, pp 1–13.
- Opitz, S., 1996. Trophic interactions of Caribbean Coral Reefs. *ICLARM Tech.* 43, 341pp.
- Ormond, R., Edwards, A., 1987. Red Sea fishes. In: Edwards, A., Head, S. (Eds.), *Red Sea*. Pergamon Press, Oxford, pp 252–287.

- Palomares, M.L., Pauly, D., 1998. Predicting food consumption of fish populations as functions of mortality, food type, morphometrics, temperature and salinity. *Mar. Freshw. Res.* 49:447-453.
- Pauly, D., 1980. On the interrelationships between natural mortality, growth parameters, and mean environmental temperature in 175 fish stocks. *J. Cons. CIEM* 39, 175–192.
- Pauly, D., Christensen, V., Walters, C., 2000. Ecopath, Ecosim and Ecospace as tools for evaluating ecosystem impact of fisheries. *ICES J. Marine Sci.* 57, 697–706.
- Pauly, D., Soriano-Bartz, M.L., Palomares, M.L.D., 1993. Improved construction, parameterization and interpretation of steady-state ecosystem models. In: Christensen V. and Pauly, D. (Eds.) *Trophic models of aquatic ecosystems*. ICLARM conf. Proc. 26, pp 1–13.
- Pinnegar, J.K., Polunin, N.V.C., 2004. Predicting indirect effects of fishing in Mediterranean rocky littoral communities using a dynamic simulation model. *Ecol. Model.* 172, 249–267.
- Polovina, J.J., 1984. Model of a coral reef ecosystem: I. The ECOPATH model and its application to French Frigate Shoals. *Coral Reefs* 3, 1–11.
- Reynolds, J.E., Appleton, J., Bellemans, M.S., Bonzon, A., Christy, L.C., 1993. The fisheries of Eritrea, pt. 1: Sector review. pt. 2: Proposed national fisheries strategy and development program. FAO, Rome.
- Roberts, C.M., Shepherd, A.R.D. Ormond, R.F.G., 1992. Large-scale variation in assemblage structure of Red Sea butterflyfishes and angelfishes. *J. Biogeogr.* 19, 239–250.
- Sanders, A.P.L. and Morgan, G.R., 1989. Review of the fisheries resources of the Red Sea and the Gulf of Aden. FAO Fisheries Technical Paper. No. 304. FAO, Rome, 138 pp.
- Sheppard, C.R.C., Sheppard, A.S.L., 1991. Corals and coral reef communities of Saudi Arabia. *12*, 3–10.
- Sheppard, C.R.C., Price, A., Roberts, C., 1992. *Marine Ecology of the Arabian Region: Patterns and processes in extreme tropical environments*. Academic Press, Cambridge, 359 pp.
- Spalding, M.D., Ravilious, C, Green, E.P., 2001. *World Atlas of Coral Reefs*. University of California Press, Berkeley, USA.
- Sparre, P., 1991. Introduction to multispecies virtual population analysis. *ICES Mar. Sci. Symp.* 193, 12–21.
- Tsehaye, I., Machiels, M.A.M., Nagelkerke, L.A.J., 2007. Rapid shifts in catch composition in the artisanal Red Sea reef fisheries of Eritrea. *Fish. Res.* 86, 58–68.
- Ulanowicz, R.E., Puccia, C.J., 1990. Mixed trophic impacts in ecosystems. *Coenoses* 5, 7–16.
- Van Couwelaar, M., 1997. Zooplankton and micronekton biomass off Somalia and in the southern Red Sea during the SW monsoon of 1992 and the NE monsoon of 1993. *Deep-Sea Res.* 44, 1213–1234

- Van Rooij, J. M., Bruggemann, H. J., Videler, J.J., 1998. High biomass and production but low energy transfer efficiency of Caribbean parrotfish: implications for trophic models of coral reefs. *J. Fish Biol.* 53, 154–178.
- Vasconcellos, M., Mackinson, S., Sloman, K.A., Pauly, D., 1997. The stability of trophic mass balance models of marine ecosystems: a comparative analysis. *Ecol. Model.* 100, 125–134.
- Veldhuis, M.J.W., Kraay, G.W., van Bleijswijk, J.D.L, Baars, M.A., 1997. Seasonal and spatial variability in phytoplankton biomass, productivity and growth in the Northwestern Indian Ocean: the southwest and northeast monsoon, 1992–1993. *Deep-Sea Res.* 44, 425–449.
- Villanueva M. C., Laleye, P., Albaret, J. J., Lae, R., Tito de Morais. L., Moreau, J., 2006. Comparative analysis of the trophic structure of two tropical lagoons. *Ecol. Model.* 197, 461-477
- Walters, C.J., Christensen, V., Martell, S.J., Kitchell, J.F., 2005. Possible ecosystem impacts of applying MSY policies from single-species assessment, *ICES J. Mar. Sci.* 62, 558–568.
- Zekeria, Z.A., 2003. Butterflyfishes of the southern Red Sea: ecology and population dynamics. Ph.D. thesis, University of Groningen, the Netherlands, 120 pp.
- Zekeria ZA, Videler J.J., 2000. Correlation between the abundance of butterflyfishes and coral communities in the southern Red Sea. In *Proceedings of the Ninth International Coral Reef Symposium, Bali; Vol. 1: 487–492.*

CHAPTER 6

General discussion

In much of the tropics, reef fish catches are on the decline, with far-reaching consequences for fish communities and coastal populations. Ecologically or socio-economically important species, such as bumphead parrotfish (*Bolbometopon muricatum*, Scaridae), humphead wrasse (*Cheilinus undulatus*, Labridae) snappers (Lutjanidae) and groupers (Serranidae) have all but disappeared from many fisheries (Dulvy et al. 2004a; Sadovy et al. 2005). Trends from FAO fisheries statistics also show that several countries, such as the Bahamas, Jamaica, Indonesia and the Philippines have experienced declining catch rates from their artisanal reef fisheries over the last couple of decades (Sadovy, 2005). These trends suggest that small-scale fishing effort and landings are increasing, and that many fisheries have already reached or possibly exceeded maximum sustainable yield (Pauly 1994, 1997; Dalzell 1996; Costa et al., 2002; Hunt 2003). Yet, despite the general concern that coral reef communities are essentially vulnerable to expansion of fisheries, reef fisheries have not been critically monitored in many parts of the tropics. These scenarios stress the need for a more effective monitoring and management of reef fisheries at local, national and international levels in order to prevent further declines, and to ensure that they continue to play an important role in supporting livelihoods for coastal communities (Sadovy et al. 2005; Bellwood et al. 2004). The main objective of this study was to assess the sustainability of existing fishing practices in the artisanal fisheries of Eritrea, while simultaneously exploring more effective ways of monitoring fisheries.

1. Trends in catch rate in the newly developing fisheries of Eritrea

Although no comprehensive assessment of the state of fisheries and fish stocks have been undertaken, it has been documented that the artisanal reef fisheries of Eritrea are at an early stage of development, with potentially little impact on the fish community (e.g., Morgan, 2006). In this study, analysis of official statistics from these fisheries showed a steady increase in effort and total annual catch over the years (Fig. 1). In addition, the total catch rate remained unchanged upon the expansion of fisheries, suggesting that the existing patterns of exploitation may be sustainable. However, disaggregation of catch rates into different taxonomic and ecological categories revealed a decline in the catch rates of the higher-value demersals, such as snappers (Lutjanidae), groupers (Serranidae) and emperors (Lethrinidae) over the years. Yet, there was little evidence that artisanal fisheries had any effects on reef-associated pelagics such as barracudas (Sphyraenidae), tunas (Scombridae) and jacks (Carangidae). Overall, the varying trends in catch rates of the different groups of fish resulted in a clear shift in catch composition over the years (Fig. 1). In view of these,

maintenance of a constant aggregated yield in such fisheries does not necessarily imply an absence of changes in fish community structure that could be of management concern.

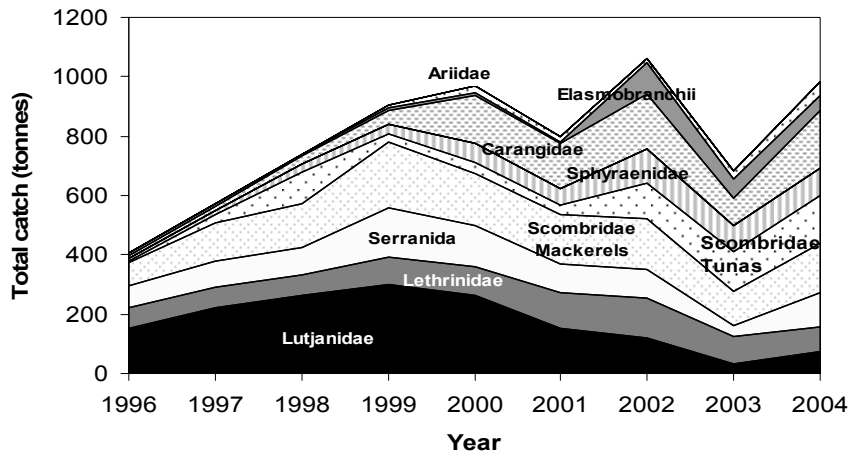

Figure 1. The evolution of catches of different groups of fishes in the artisanal fisheries.

Catch rate and composition have been used as general indicators of the extent of exploitation in reef fisheries (Jennings and Lock, 1996). Munro and Smith (1984), Lock (1986), Koslow et al., (1988) and Jennings and Lock (1996), for example, suggested different levels of exploitation for multispecies and multigear fisheries, each characterized by a specific catch rate and composition. At light to moderate levels of exploitation, catch rates will normally be high, with large predatory species, e.g. groupers and snappers, dominating hook and line catches and large herbivores, e.g. surgeonfishes (*Acanthuridae*) dominating gillnet catches. As fishing pressure increases, catches of these species decline over a short period, and with fewer large fishes available, netting is adopted as the main fishing method. In moderately exploited fisheries, small emperors dominate catches with all fishing methods. At high level of exploitation, hook and line fishing is eventually replaced by gillnetting, with the catches being mainly small herbivores fishes, e.g. rabbitfishes (*Siganidae*). Thus, given that the catches from the artisanal reef fisheries of Eritrea are still mainly composed of long-lived, high trophic level species, we may conclude that these fisheries are only lightly exploited. On the other hand, the shifts in catch composition registered for these fisheries at such an early stage indicate that reef-associated species cannot withstand high levels of fishing pressure. This is particularly so for the stocks of predatory species, which already show a sign of decline at such low levels of fishing. These

trends are also consistent with fishers' reports that the stocks of the higher-value demersal species such as snappers and groupers were less readily available over the years (various fishers, personal communication).

The trends in catch rates of reef-associated demersals observed in these fisheries, albeit based on short time-series data, are consistent with findings from other studies, suggesting that small-scale fisheries can even exploit reef fishes beyond their sustainable limits in a short period (Pauly, 1994, 1997; Dalzell 1996; Hunt 2003). Significant declines in catch rate and composition have been reported for fisheries with levels of exploitation equivalent to or even lower than in the artisanal fisheries of Eritrea. For example, Jennings and Polunin (1996) showed that for some Fijian reef fish communities, low levels of fishing effort – some of which were an order of magnitude lower than those in some other parts of these fisheries – resulted in a decline (of up to 50%) in the biomass of emperors, snappers and groupers. They also suggested that annual catch rates equivalent to about 5% of the standing biomass resulted in significant differences in fish community structure between reserves and adjacent areas. In Netherlands Antilles and Belize, Polunin and Roberts (1993) registered differences of up to 50% in abundance and biomass of demersal reef fishes between a marine reserve and an adjacent area subjected only to a small amount of recreational fishing. In a similar study in Kenya, Watson & Ormond (1994) recorded significant differences in abundance and biomass between a reserve and an adjacent area subjected only to limited artisanal fishing. The decline in reef-associated demersals in the artisanal fisheries of Eritrea also parallels findings from the Indo-Pacific and the Indian Ocean off the coast of Kenya, where declines in carnivorous fishes were the most detectable effects of fishing pressure in multispecies reef fisheries (Russ, 1991; Jennings and Polunin, 1997; McClanahan and Mangi, 2001; Pet Soede et al., 2001; Kaunda-Arara, et al., 2003).

Fishing is expected to have varying effects on fishes with different life history strategies (Jennings and Lock, 1996; Jennings et al., 1999). Species with short life span and rapid population growth are likely to withstand higher levels of fishing mortality. If fishing is reduced, these species can recover quickly from minimum population size caused by overfishing. Slow-growing piscivorous species, on the other hand, are vulnerable to intensive exploitation because of their low fecundity and lower intrinsic rate of population growth. In addition, many of these fishes are site attached, making them yet more vulnerable to exploitation. The effects of fishing are thus rapidly reflected in reef fisheries and their rate of recovery will be slow, because many of the target fishes are mainly of slow

growing type. The removal of such species does not only result in rapid over-exploitation of the target species but also have far-reaching effects on coral reef ecosystems, potentially resulting in permanent ecosystem shifts to less desirable states, as suggested by theoretical and empirical models (Beddington, 1984; Scheffer et al., 2001; Bellwood et al. 2004).

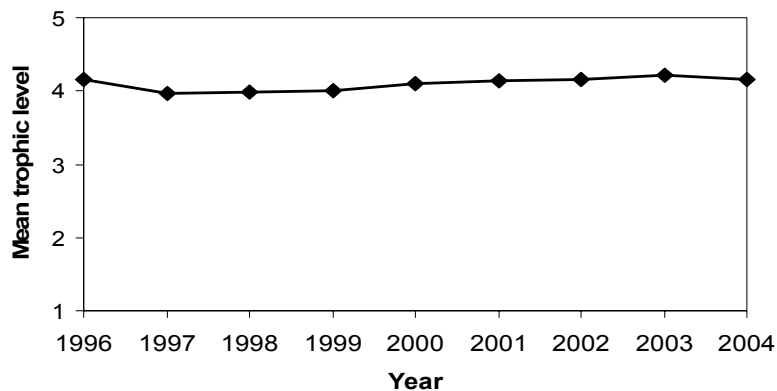

Figure. 2. Mean trophic level of fishes in the catch from the artisanal fisheries of Eritrea.

Finally, the changes in catch composition in the artisanal fisheries of Eritrea are reminiscent of the gradual transition in global catches from higher-value demersal fishes to lower-value pelagic fishes, with a possible risk of "fishing down the food webs". Even though, no real "fishing down the food webs" phenomenon has occurred as yet (Fig. 2), it can be envisaged that the rapid decline in predatory species will lead to shifts in fish targeting from higher towards lower trophic level species. Such speculations are consistent with studies suggesting that trophic structure of coral reef ecosystems can be modified even by fishing of relatively lower intensity. It has also been widely documented that selective removal of top predators can have far-reaching consequences for the overall community structure through top-down effects of fishing on ecosystems (Dulvy et al., 2004a; McClanahan and Mangi, 2004).

2. Catch rate as an indicator of changes in fish community in the absence of fishery-independent data

Just as in most reef fisheries, only limited research has been conducted on the state of reef fish stocks of Eritrea, making the artisanal reef fisheries data-limited. In such data-limited

situations, the use of catch and effort data is the most practical option for studying the effects of fishing on fish populations (Sparre and Venema, 1998; Vasconcellos and Cochrane, 2005). Given their marked sensitivity to even low fishing intensity, catch rates of carnivorous and piscivorous species are actually very good indicators of fishing pressure. Indeed, an appropriate use of catch rate data as an indicator of abundance is a critical technical issue with important management implications (Hampton et al., 2005). Often, the ecological interpretation of trends in catch rate is far from straightforward, as illustrated by the controversy surrounding Myers and Worm's (2003) prominent study on the rapid depletion of Pacific tuna populations (Hampton et al. 2005; Polacheck 2006; Sibert et al., 2006). In many reef fisheries, there are no sufficient fishery-independent data to provide more than a speculative interpretation of the mechanisms underlying the changes in catch rate and composition, and this is often derived from the theoretical relationships between catch rate and effort, e.g. Schaefer model (Schaefer, 1954). In addition, changes in catch composition or a decline in catch rate at very low fishing effort and biomass removal do not necessarily reflect a proportional decline in fish biomass. Rather, an initial decline in catch rate could simply be due to "hyperdepletion", which is more a reflection of a decline in catchability as the susceptible subset of a population is removed by fishing (Hilborn and Walters 1992; Walters 2003; Hampton et al. 2005). In many cases, catch rate drops rapidly and tends to stabilize at a lower level as the fishery becomes completely dependent upon the recruitment of new fish to the population (Myers and Worm, 2003). Moreover, while the interpretation of the catch rate as an index of community biomass rests on the assumption that catchability (a coefficient specifying the effectiveness of fishing and hence the proportionality between catch rate and abundance) is constant over time, such might not hold true for all fisheries or over a wide range of effort levels (Hilborn and Walters 1992; Hampton et al. 2005). Thus, changes in catch rate may arise not only from changes in stock biomass but from changes in catchability, and it is also possible that both factors simultaneously influence the relationship between catch rate and fishing effort. For example, in many fisheries, newer gear is often more effective than older gear, potentially obscuring continuing declines in stock abundance.

In the artisanal fisheries, even though the mechanisms underlying the changes in catch rate are not yet fully understood, a better knowledge of the catch rate–effort relationship could help in the interpretation of observed trends. Thus, given that declines in catch rate do not always reflect proportional declines in biomass, a rapid decline in catch rate during the early development of the multispecies fisheries of Eritrea might be expected and does not necessarily imply that the fish stocks are highly exploited. On the other hand, substantial

changes that affect catch rate can still occur at very low effort levels and may well be ecologically important (Lorenzen et al., 2006). Thus, the changes in catch rate in the artisanal fisheries could be interpreted as reflecting changes in the underlying fish community structure. These findings are also consistent with other studies suggesting that stocks of reef-associated demersal species are highly vulnerable to fishing and can decline even at the early stages of fisheries. Furthermore, these results are not unlikely given the supposedly large amounts of unreported catches, which are mostly taken illegally to Yemen. Moreover, no changes in fishing techniques (and hence catchability) were observed over the years, making it more likely that changes in catch rate in these fisheries reflect changes in fish abundance rather than changes in catchability.

Indeed, the mechanisms underlying such a rapid decline in catch rate observed at low levels of effort require further investigation in order to determine their ecological significance. Since fisheries assessment cannot be entirely based on examination of trends in catch rates alone, biological data derived from fishery-dependent and independent surveys – such as size composition, tagging and biological data – will be required to investigate the effects of fishing more directly and to validate the ecological changes implied by catch rate and composition. Nevertheless, even though the changes in catch rate in the artisanal fisheries could be interpreted as reflecting changes in the underlying fish community structure, they could also be in part due to shifts in fish targeting strategies driven by socio-economic circumstances, as discussed in the following section.

3. Socio-economic considerations in monitoring trends in catch rate

Compared with the ecological investigation of fish populations, the socio-economic aspects of fisheries have been largely neglected in fisheries assessment and management (Dalzell and Wright, 1990; Cinner and McClanahan, 2006). The findings from the artisanal fisheries of Eritrea highlight the need to address the socio-economic aspects of fisheries alongside the biological dynamics of fish stocks in the monitoring of fishing impacts. Unlike most reef fisheries in the developing world, where there is no such a thing as a "trash fish" (Munro, 1996), the artisanal fisheries of Eritrea are highly selective, targeting high trophic level, piscivorous species for their higher market value. Such fisheries can be characterized as less efficient and more wasteful than most reef fisheries in terms of supporting coastal communities. The highly selective nature of the artisanal fisheries is apparently related to that fact that fish is not an important element of the Eritrean diet, resulting in the fisheries mainly targeting the commercially most important fishes for export markets. In the past, for

example, the artisanal fishers often discarded tunas as “trash fish” because of their low demand in the local market (Reynolds et al., 1993). At present, however, tunas are categorized as “second grade fish” for the domestic market¹ (personal observation). In this study, socio-economic factors were found to account for a considerable proportion (19.4%) of the changes in catch composition in the artisanal fisheries over the years. Under such circumstances, changes in catch rate of the different target species cannot accurately reflect changes in fish community structure. This underlines the importance of socio-economic factors, and more specifically, fishers' behavior, in governing fish targeting strategies in the artisanal fisheries. The importance of socio-economic factors was also registered for fisheries elsewhere. For example, in the early 1960s, Japanese longliners changed from targeting albacore (*Thunnus alalunga*) and yellowfin (*T. albacares*) for a canned-tuna market to bigeye (*T. obesus*) and yellowfin tuna for a Japanese sashimi market. The catch rate for albacore in Japanese longline fishery thus declined rapidly not because of declining albacore abundance, but because of the change in species targeting (Hampton et al., 2005). It has also been documented that different socio-economic drivers govern the allocation of fishing effort in small-scale reef fisheries, and thus they need to be considered explicitly when undertaking fisheries assessments (Teh et al., 2005).

Changes in fish targeting strategies mainly occur because fishers do not operate at random but take into account information on resource availability and revenues generated from fishing before selecting or changing a target (Salas et al., 2004). The complexity of small-scale multispecies fisheries however makes it difficult to assess the allocation of fishing effort among alternative target species, and hence to detect changes in fish targeting strategies over time. Often, fishing effort is recorded as an aggregate, without consideration of how it is apportioned among different target species (Salas et al., 2004; Branch et al., 2006; Grafton et al., 2006).

In this study, the correlations between long-term trends in some relevant socio-economic parameters – such as the relative prices of the different groups of target fishes and costs of fishing – and catch rates of these fishes were determined in a multivariate model, aiming to examine the relative importance of socio-economic factors in driving shifts in fish targeting strategies over the years. Long-term trends in catch rate and effort can nevertheless be blurred by short-term random or non-random fluctuations. Thus, we can gain a better insight into the association between catch rates and effort (and hence socio-economic

¹ Ministry of Fisheries. 2002. Available at the Ministry of Fisheries Library, P.O. Box 18, Massawa, Eritrea.

factors) by accounting for short-term decisions of fishers related to selection of fishing location and target species. A study of the small-scale fisheries in Yucatan, Mexico, for example, indicated that a seasonal increase in octopus price would induce a change in targeting, even though lobster still had a higher price. These changes were caused by lower costs for octopus fishery but could also be a reflection of the less demanding skills for this fishery as compared with lobster (Salas et al., 2004). Random fluctuations in catch rate and effort, on the other hand, can be minimized by aggregating catch and effort data over a longer time interval – although this might come at the risk of losing of some degrees of freedom. In this study, aggregation of catch rates on monthly basis resulted in a considerable reduction in random variability, allowing the association between catch rates and socio-economic variables to become more evident. Finally, the results from this study indicate that even though the changes in catch rate in the artisanal fisheries could be interpreted as reflecting changes in the underlying fish community structure, they could also be partly due to shifts in fish targeting strategies driven by socio-economic circumstances, such as changes in the relative prices of fish and costs of fishing.

4. Improving the effectiveness of monitoring programs

In the absence of sufficient biological data for the direct interpretation of the ecological significance of trends in catch rate, it is important to ensure an accurate and effective use of catch and effort data for the monitoring of fisheries and fish stocks (Sadovy, 2005). In this regard, fishery-dependent data can be used more effectively by adjusting catch rates for all factors that can possibly cause non-random (systematic) variations in catch rate unrelated to abundance (e.g. gear type, boat type, crew size, days at sea etc.) (Bishop, 2006). Besides minimizing bias, the removal of systematic differences in catch rate can also result in a considerable reduction in temporal variability, improving the statistical power to detect trends in catch rate. In view of these, it is important to optimize catch and effort recording systems in such a way as to account for as many of sources of bias as possible in the collection of data, particularly in the absence of sufficient resources for the collection of fishery-independent statistics.

For the artisanal fisheries of Eritrea, trends in catch rate could be elucidated more accurately by standardizing catch rates for systematic variations among fishing vessels, fishing locations, seasons etc. While the existing catch and effort data recording system (CEDRS) in the artisanal fisheries allows for some of these differences to be accounted for, as it comprises of data on, among other things, boat type, gear type, crew size, and number

of days at sea, it does not allow for standardization of catch rates for other sources of bias. For example, small-scale spatial variations in catch rates could not be accounted for because of the low spatial resolution of the data recoding system (an analysis at a 50 x 50 km scale nevertheless revealed no significant variations in catch rate). Thus, it is important to optimize the sampling and monitoring programs in the artisanal fisheries so that they would permit the collection of more diverse data, thereby allowing a more accurate interpretation of the ecological significance of trends in catch rate. Optimal sampling strategies can be developed by refining existing procedures for the collection of catch and effort statistics and by treating observed combinations of gear, effort, catch composition, location etc. as a series of experimental replications (Jennings and Lock, 1996).

The effectiveness of existing monitoring programs can also be improved through aggregation of catch data. In many fisheries, trends in catch rate of individual species are blurred by high inter-annual variability (Anderson et al., 1997; van Oostenbrugge et al., 2002). By contrast, aggregation of catch data can result in a considerable reduction in temporal variability, allowing trends in catch rate to become more apparent. Nevertheless, aggregation of catch data across all species may obscure trends in the abundance of individual species as total catch rate often tends to remain constant despite varying trends in the abundance of these species. Therefore, the choice of an appropriate level of aggregation requires trade-offs between reducing variability to achieve a higher statistical power on one hand and attaining an accurate depiction of temporal trends in catch rates on the other. In the Eritrean artisanal fisheries, aggregation of catch data across all species was found to obscure trends in catch rates of individual species, suggesting an underlying heterogeneity in species' responses to fishing. Therefore, an accurate depiction of trends could only be achieved by aggregating the multispecies catch rate data into more homogenous categories, which can be defined based on life histories and spatial distribution of fish. The multispecies catch data from the artisanal reef fisheries could be aggregated into three ecological categories, which were defined based on the degree of co-occurrence of species in the catch (no contrasting life histories were found among the target species), without a considerable loss of information on trends in catch rates of individual species. These categories include reef-associated demersals, open-water pelagics and near-reef pelagics. For these fisheries, aggregation of catch data into these distinct ecological categories was found to improve the statistical power to detect overall trends. More importantly, aggregation of catch data was found to improve the statistical power in the analysis of trends in catch rates of reef-associated demersal species, which was otherwise inconclusive at species level (Fig. 3). A negative trend became apparent when the catch data of these

species were aggregated into one category. Indeed, improving statistical power to detect trends is particularly important if management of vulnerable fish stocks requires evidence of highly significant trends (Maxwell and Jennings, 2005). Besides improving statistical power to detect trends, aggregate catch rates were shown to provide better insight into community-level responses to exploitation in these fisheries.

Figure 3. Trends in catch rate of reef-associate demersals before and after aggregation of

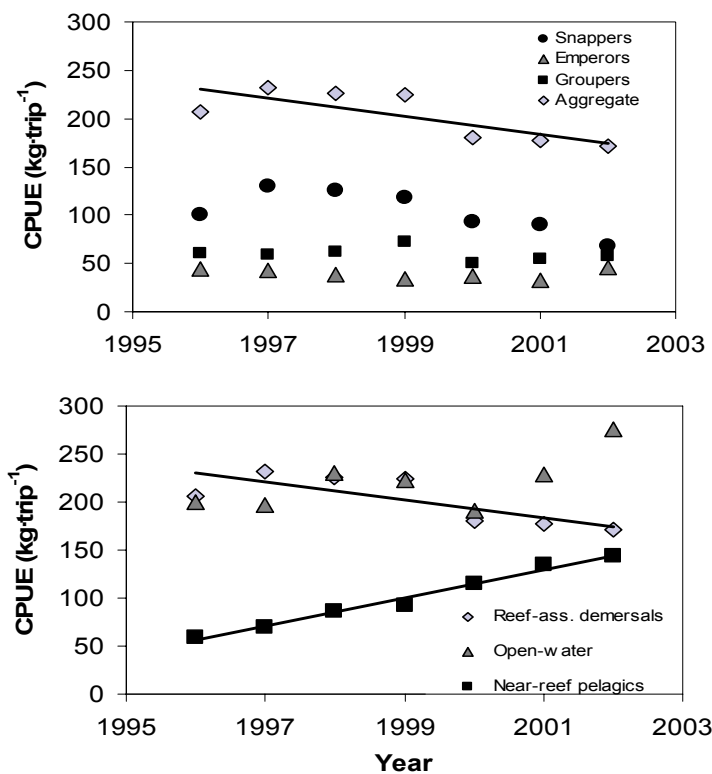

catch data (a linear regression is fitted if trend is significant at $\alpha \leq 0.05$) (top panel); trends in aggregate catch rates of reef-associated demersals, open water pelagics and near-reef pelagics (a linear regression is fitted if trend is significant at $\alpha \leq 0.05$) (bottom, panel).

Aggregate catch rates have been used in several studies of fishing impacts in multispecies fish communities (Lorenzen et al., 1998; Myers and Worm, 2003; Nguyen Khoa et al., 2005). The use of aggregate catch rates can have important consequences for the assessment and management of tropical fisheries, which are mostly of a multispecies nature, with any given type of fishing gear capturing a wide range of species and where

resources for data collection are limited. Besides improving the statistical power of monitoring programs, aggregate catch rate is an important indicator of the exploitation status in such fisheries for several reasons. For example, aggregate catch rates provide a better insight into ecosystem-level responses to fisheries exploitation (Fig. 3). In addition, aggregate yield can be related more directly to the production and socio-economic benefits derived from a fishery. Aggregated yield and catch rate can thus complement other community indices, such as the mean trophic level of landings, mean size of fish in the catch, or the slope of biomass size spectra, as a tool for the assessment of impacts of fishing on exploited communities and ecosystems, (Pauly et al. 1998; Welcomme 1999; Rochet and Trenkel, 2003; Lorenzen et al., 2006). Lastly, the reduction in random variability upon aggregation of catch data has important consequences for the optimization of sampling programs, allowing the reallocation of sampling resources for the collection of more diverse data.

5. Ecological modeling as a tool for monitoring fisheries

Modeling is a useful tool to verify the ecological significance of trends derived from fishery-dependent statistics (Christensen and Walters, 2004). Yet, given the high species diversity and the multiplicity of fishing gear and craft in the artisanal reef fisheries – like all multispecies, multigear fisheries – the application of traditional fish stock assessment models requires a wide-range of information on the structure and functioning of reef fish assemblages and their response to fishing. In addition, the scarcity of ecological data in the artisanal fisheries of Eritrea – again like most reef fisheries in the developing world (Larkin, 1996; Bundy and Pauly, 2001) – makes the application of traditional assessment methods yet more difficult (Magnusson, 1995; Sparre and Venema, 1998). Therefore, the use of methods with meager data requirements are suggested as being the most viable option for evaluating the status of such fisheries and exploring optimal fisheries management scenarios in the artisanal fisheries (Bundy and Pauly, 2001).

The mass-balance ecosystem model Ecopath with Ecosim is widely used to explore optimal harvesting strategies by examining the ecosystem effects of fishing (Pauly et al., 2000; Christensen and Walters, 2004). This approach does not need to explicitly address the full complexity of ecosystems, yet provides an ecological perspective for the assessment and management of multispecies, multigear fisheries (Pauly et al., 2000). This modeling approach is based on the assumption of mass-balance to describe the structure and functioning of ecosystems, and allows temporal and spatial simulations that can be robust

even in data-sparse environments (Christensen and Walters, 2004). Ecopath with Ecosim models were used in several studies to investigate the impacts of fishing on coral reef ecosystems, thereby exploring optimal fishing strategies (Arias-Gonzalez et al., 2004; Bundy and Pauly, 2004). Similarly, an Ecopath with Ecosim model was used in this study to integrate known aspects of the reef ecosystems off Eritrea's Red Sea coast and their inhabitants into a single framework, with the aim to gain a better insight into the responses to exploitation of target and non-target species in this relatively poorly studied ecosystem. Ecosim simulations were used to verify if the fishery-induced changes in yield and abundance of reef-associated fishes implied by official statistics are likely, given the existing levels of fishing intensity as suggested by these statistics. A retrospective simulation of trends for these fisheries using Ecosim showed that, given the existing fishing intensity as suggested by official statistics, the declines in yield and abundance of reef-associated demersals of the magnitude suggested by trends in catch rate are unlikely. The decline in yield observed in these fisheries could however be reproduced in an Ecosim simulation when the existing fishing level was assumed to be fivefold the official estimate, as suggested by anecdotal evidence on unreported catches, which are mostly taken illegally to Yemen (Moussalli and Haile, 2001). The simulation results show that an optimal fishing strategy could be achieved for these fisheries through a slight reduction in the annual catch of reef-associated fish and an increase in the capture of near-reef pelagics and large pelagics from the putative levels. In conclusion, even if modeling is no substitute to fish stock assessment with more detailed data, it could greatly improve our understanding of the impacts of fishing on the structure and functioning of coral reef ecosystems in such newly developing fisheries, thereby allowing for optimization of fishing strategies.

6. Implications of trends in catch rate for the management of fisheries

Despite major advances in statistical and computational techniques, it is often too difficult to provide accurate prediction of the potential yield for most reef fisheries using conventional methods of population analysis, mainly because of lack of data. Nevertheless, a better understanding of fishing effects may allow the development of a range of alternative assessment, management and monitoring tools (Jennings and Lock, 1996). Indeed, understanding changes in catch rates might not be enough to prevent depletion of fish stocks. Rather, such an understanding provides the basis for the application of precautionary management strategies, allowing us to respond to changes in reef fish ecosystems with appropriate measures before fish communities undergo irreversible

changes (Hilborn and Walters, 1992; Kuster et al., 2005)

In most reef fisheries, impacts of fishing have often been investigated across gradients where fishing itself is rather not adequately quantified or fishing effects are rarely studied for sustainable fisheries. Thus, most studies of fishing impacts fell into one of three categories, including those that compare fish populations in fished and essentially unfished areas such as reserves, those that describe fishing effects across ill-defined gradient where details of catch composition, gear-specific effort and historical changes in effort are not quantified and those that describe responses to catastrophic rather than sustainable fishing practices. Nevertheless, after such false starts, there is increasing recognition that examination of fishing impacts (and hence the relationship between catch rate and effort) in sustainable fisheries is important for the management of reef fisheries. Indeed, a better understanding of fishing impacts requires rather more accurate quantitative studies that relate specific fishing effects to a wide range of fishing regimes (Jennings and Lock, 1996). Quantitative relationships derived between catch rate, catch composition and fishing effort at different stages in the development of fisheries could then provide useful information for the optimization of fishing strategies (Jennings and Lock, 1996, Hilborn and Walters, 1992). In view of the above, even if there were no compelling evidence suggesting major shifts in fish community structure in the artisanal fisheries in Eritrea, it is still important to study such fisheries before the fish communities undergo catastrophic changes (Jennings and Polunin, 1996b; Kuster et al., 2005).

The management implications of the trends in catch rate observed in the artisanal fisheries are that even relatively benign fishing practices (e.g. hook and line) sustained at relatively low levels of effort are capable of modifying the structure of reef fish populations and require active management controls. The findings from this study also support the argument that non-selective fishing by multispecies cropping across all trophic levels can minimize the probability of ecosystem shifts (Kuster et al., 2005). Furthermore, the varying trends in the catch rates of the different fish categories observed in the artisanal fisheries can provide the basis for the estimation of potential quantity and composition of yields for these fisheries, thereby allowing the optimization of fishing strategies among the various target species.

Moreover, although the artisanal fisheries might still appear to be productive enough to meet the existing demands, the increased interest on the part of the government to modernize the fisheries is expected to result in increased entry of new fishers, potentially

leading to overexploitation of the resources. It has been suggested that, under certain circumstances, an economically inefficient fishery might be preferable for the conservation of resources (Kronen, 2004). In theory, the behavior of fishers under normal circumstances often follows the predictions of a simple bio-economic model. In an open access fishery in an area with abundant unemployed labor, new entrants are attracted to a fishery until the bio-economic equilibrium is reached, and no fisher can make a profit. The level of exploitation at bio-economic equilibrium is generally well beyond the fishing effort for maximum sustainable yield, and can cause serious decline of fish stocks. At worst, expansion of the fisheries can also lead to Malthusian overfishing, where fishers initiate wholesale resource destruction in order to maintain their livelihoods in the face of declining stocks (Pauly, 1994; Pauly et al., 2002). The results from this study suggest that the impacts of fishing on fish communities in the artisanal fisheries could even become more severe if market conditions improve leading to activation of a latent fishing capacity, which was found to make up about 75% of the registered fleet.

Once impacted, fish populations in coral reef systems might need decades to recover from overfishing (McClanahan et al., 2007). More importantly, the ecological equilibrium needed for a healthy reef system, one that relies on the interplay of many fish, invertebrate, and plant species, takes even longer to achieve (McClanahan et al., 2007). In view of these, fishing strategies that minimize changes in community structure appear to offer the best prospects for the management of multispecies fisheries. In the artisanal fisheries, since gears mainly target specific species of fish, they can be selectively controlled as a management option to control the capture of vulnerable species. By contrast, conventional yield models could provide inappropriate estimates of yield, which allow the reduction of fish stocks to a theoretical point of maximum biomass regeneration, potentially causing proliferation of non-target species.

7. Conclusions and future research prospects

Elucidating trends in catch rate and composition is important to evaluate the state of fish stocks and guide future fisheries management action in newly developing fisheries. In this study, shifts in catch composition were registered for the artisanal fisheries of Eritrea, which was launched into a renewed development after a decades-long standstill, which was caused by Eritrea's war for independence. These changes mainly involved a decline in the catch rate of reef-associated demersals and a simultaneous increase in the catch rate of reef-associated pelagics. The changes in catch composition could not be attributed to changes in

spatial allocation of fishing effort or to improvements in fishing techniques, making it unlikely that they were caused by changes in fish targeting strategies. Yet, such rapid changes in catch rate or composition cannot necessarily be due to changes in fish community, and may simply be due to "hyperdepletion", a phenomenon that could be more pronounced in the case of the highly vulnerable reef-associated demersals. Yet, the trends in CPUE of demersal fishes could represent more than just hyperdepletion even at the early stages of fisheries, given that the stocks of reef-associated demersal fishes are highly vulnerable to fishing. Overall, the multivariate analysis of catch rates in relation to biological and socio-economic factors shows that while the changes in catch rate and composition in the artisanal fisheries of Eritrea could indeed represent considerable ecological changes, the shifts in catch composition could also be partly explained by changes in the socio-economic circumstances within which the artisanal fisheries operate.

Elucidating trends in catch rate in relation to fishing effort would prove more difficult for small-scale fisheries, which mostly involve heterogeneous fishing practices, with a large number of fishers, a wide range of boat and gear types, fishing grounds etc., and targeting a wide variety of species. A more accurate interpretation of the relationship between catch rate and effort could nevertheless be made for the artisanal fisheries by standardizing catch rates for systematic variations among fishing vessels, which would cause non-random variations in catch rate unrelated to abundance. A more comprehensive monitoring program would allow yet a more accurate interpretation or prediction of catch rate in relation to variation in effort by allowing us to check and correct catch data for other potential sources of bias. The effectiveness of monitoring programs can thus be improved by refining existing procedures for the collection of catch and effort statistics and by treating observed combinations of gear, effort, catch composition, location etc. as a series of experimental replications. Indeed, to directly investigate the effects of fishing and to validate the ecological changes implied by trends in catch rate and composition, fishery-dependent assessments should be confronted with fishery-independent data, which were unfortunately unavailable for the present fisheries. Thus, to allow a direct interpretation of trends derived from catch and effort statistics, the existing catch and effort data recording system in the artisanal fisheries ought to be coupled with a systematic collection of fishery-dependent and independent biological data.

In addition, the effectiveness of existing monitoring programs can also be improved through aggregation of catch data. The reduction in random variability up on aggregation of catch data is also shown to have important consequences for the optimization of catch and

effort recording system in these fisheries. An optimum catch and effort recodign system allows the reallocation of sampling resources for the collection of a wider variety of fishery-dependent and independent data. Generally, collection of fishery-dependent biological data, such as taking length measurements of fish in the catch, can be made from catches aboard fishing boats or from landings at fishing harbors. Fishery-independent data, on the other hand, are often obtained using visual census techniques. However, visual census techniques have been the subject of wide-ranging critical discussion in recent years suggesting that they could underestimate the numerical abundance or biomass of many species. Yet, some studies compared catch rate and visual census and suggested that they would provide similar estimates of relative abundance (Haggarty and King, 2006).

Modeling has also been shown to be a useful tool for examining the ecological significance of trends derived from fishery-dependent statistics in the artisanal fisheries. Nevertheless, even though this study showed that modeling could provide useful insights into the impacts of fishing on the structure and functioning of coral reef ecosystems in such newly developing fisheries, a more accurate prediction of fishing responses could be made through a more rigorous analysis of fish stocks with detailed data. Thus, ecosystem-based fisheries management is not meant to replace stock assessments. Instead, they provide a perspective with which we can optimize fishing strategies among different target species. In fact, ecosystem-based approaches mainly draw their input data from single-species stock assessments. Thus, it is important to distinguish between fishing scenario exploration, which is strategic and made in light of the ecosystem effects of fishing, and stock assessment, which is tactical and mainly applied to estimate stock-specific potential yields. For this purpose, more effort needs to be devoted to the collection of data for species-specific fish stock assessment.

Finally, the management implication of the trends in catch rate and composition registered for the artisanal fisheries is that major changes in fish community can take place even at the initial stages in the development of fisheries, and thus they need to be critically monitored. In addition, the concentration of fishing effort on selected species and/or specific areas could have adverse consequences for the sustainability of reef fisheries. Therefore, the continued strong economic incentive for the artisanal fishers to mainly target reef-associated demersal fishes remains a cause for concern in the management of these fisheries. The results from this study also suggest that the impacts of fishing in the artisanal fisheries could even become more severe if market conditions improve leading to activation of a latent fishing capacity, which was found to make up about 75% of the registered fleet.

In view of the above, even though there is no evidence of drastic declines of fish stocks in the artisanal fisheries as yet, it is important that fishing activities are well dispersed over the whole range of coastal and island reef, and open water systems, and target a more diverse array of species before the fisheries undergo irreversible changes.

References

- Anderson, P.J., Blackburn, J.E. & Johnson, B. A., 1997. Declines of forage species in the Gulf of Alaska, 1972-1995, as indicators of regime shift. In: Baxter, B. S. (Ed.), *Proceedings of the International Symposium on the Role of Forage Fishes in Marine Ecosystems* Anchorage, Alaska, pp. 531-543.
- Arias-Gonzalez, J. E., Nunez-Lara, E., Gonzalez-Salas, C., Galzin, R., 2004. Trophic models for investigation of fishing effect on coral reef ecosystems. *Ecol. Model.* 172, 197-212.
- Beddington, J.R., 1984. The response of multispecies systems to perturbations. In: R.M. May (Ed.), *Exploitation of Marine Communities*, Springer-Verlag, Berlin, pp. 209-225.
- Bellewood, D.R., Hughes, T.P., Folke, C., Nystrome, M., 2004. Confronting the coral reef crisis. *Nature* 429, 827-833.
- Bishop, J., 2006. Standardizing fishery-dependent catch and effort data in complex fisheries with technology change. *Rev. Fish. Biol. Fish.* 16, 21-38.
- Branch, T.A., Hilborn, R., Haynie, A.C., Fay, G., Flynn, L., Griffiths et al, 2006. Fleet dynamics and fishers behavior: lessons for fisheries managers. *Can. J. Fish. Aquat. Sci.* 63, 1647-1668.
- Cinner, J.E., McClanahan, T.R., 2006. Socio-economic factors leading to overfishing in an artisanal coral reef fishery. *Environmental Conservation* 33, 73-80.
- Bundy, A., Pauly, D., 2001. Selective harvesting by small-scale fisheries: ecosystem analysis of San Miguel Bay, Philippines. *Fish. Res.* 53, 263-281.
- Christensen, V., Walters, C., 2004. Ecopath with Ecosim: methods, capabilities and limitations. *Ecol. Model.* 172, 109-139.
- Costa, P.A.S., da Braga, A.C., da Rocha, L.O. F., 2003. Reef fisheries in Porto Seguro, eastern Brazilian coast. *Fish. Res.* 60, 577-583.
- Dalzell, P., 1996. Catch rates, selectivity and yields of reef fishing. In: Polunin, N.V.C., Roberts, C.M. (Eds.), *Tropical Reef Fisheries*. Chapman and Hall, London, pp. 161-192.
- Dalzell, P., 1998. The role of archaeological and cultural-historical records in long-range coastal fisheries resources management strategies and policies in the Pacific islands. *Ocean Coast. Manage.* 40, 237-252.
- Dalzell, P., Adams, T.J.H., 1997. Sustainability and management of reef fisheries in the Pacific islands. In: *Proceedings of the Eighth International Coral Reef Symposium*, vol. 2,

- Panama, pp. 2027–2032.
- Dalzell P.J., Wright A., 1990. Analysis of catch data from an artisanal coral reef fishery in the Tigak Islands, Papua New Guinea. *Papua New Guinea Journal of Agriculture, Forestry and Fisheries* 35, 23-36.
- Dulvy, N.K., Freckleton, R.P., Polunin, N.V.C., 2004a. Coral reef cascades and the indirect effects of predator removal by exploitation. *Ecol. Lett.* 7, 410-416.
- Dulvy, N.K., Polunin, N.V.C., Mill, A.C., Graham, N.A.J., 2004b. Size structural change in lightly exploited coral reef fish communities: evidence for weak indirect effects. *Can. J. Fish. Aquatic. Sci.* 61, 466-475.
- Grafton, R. Q., Arnason, R., Bjørndal T., Campbell, D., Campbell, H., Clark, C. W. et al., 2006. Incentive-based approaches to sustainable fisheries. *Can. J. Fish. Aquat. Sci.* 63, 699-710.
- Hampton, J., Sibert, J.R., Kleiber, P., Mazunder, M.N., and Harley, S.J., 2005. Decline in Pacific tuna populations exaggerated? *Nature* 434, 38.
- Haggarty, D. R., King, J.R., 2006. CPUE as an index of relative abundance for nearshore reef fishes. *Fish. Res.* 81, 89-93.
- Hilborn, R., Walters, C.J., 1992. *Quantitative fisheries stock assessment*. Chapman and Hall, London, UK.
- Hunt, C., 2003. Economic globalization impacts on Pacific marine resources. *Marine Policy* 27, 79-85.
- Jennings, S., Lock, J.M., 1996. Population and ecosystem effects of fishing. In: Polunin, N.V.C., Roberts, C.M. (Eds.), *Tropical Reef Fisheries*. Chapman and Hall, London, pp. 193-217.
- Jennings, S., Polunin, N.V.C., 1996. Effect of fishing effort and catch rate upon the structure and biomass of Fijian reef fish communities. *J. Appl. Ecol.* 33, 400-412.
- Jennings, S., Polunin, N.V.C., 1997. Impact of predator depletion by fishing on the biomass and diversity of non-target reef fish communities. *Coral Reefs* 16, 71-82.
- Jennings, S., Reynolds, J.D., Polunin, V.C., 1999. Predicting the vulnerability of tropical reef fishes to exploitation with phylogenies and life histories. *Cons. Biol.* 13, 1466-1475.
- Kaunda-Arara, B., Rose, G.A., Muchiri, M.S., Kaka, R., 2003. Long-term Trends in Coral Reef Fish Yields and Exploitation Rates of Commercial Species from Coastal Kenya Western Indian Ocean. *J. Mar. Sci.* 2, 105-116.
- Koslow, J.A., Hanley, F., Wicklund, R., 1988. Effects of fishing on reef fish communities at Pedro Bank and Port Royal cays, Jamaica. *Mar. Ecol. Progr. Ser.* 43, 201-212.
- Kronen M., 2004. Fishing for fortunes? A socio-economic assessment of Tonga's artisanal fisheries. *Fish. Res.* 70, 121-134.
- Kuster, C., Vuki V.C., Zann, L.P., 2005. Long-term trends in subsistence fishing patterns and coral reef fisheries yield from a remote Fijian island. *Fish. Res.* 76, 221-228.

- Larkin, P.A., 1996. Concepts and issues in marine ecosystem management. *Rev. Fish. Biol. Fish.* 6, 139-164.
- Lock, J.M., 1986. Fish yields of the Port Moresby barrier and fringing reefs. Dept Primary Ind., Port Moresby, Papua New Guinea, Tech. Rep. Fish. Divn, 86/2, 17pp.
- Lorenzen, K., Almeida, O., Arthur, R., Garaway, C., Khoa, S.N., 2006. Aggregated yield and fishing effort in multispecies fisheries: an empirical analysis. *Can. J. Fish. Aquat. Sci.* 63, 1334-1343.
- Magnusson, K.G., 1995. An overview of the multispecies VPA-theory and applications. *Rev. Fish Biol. Fish.* 5, 195-212.
- Maxwell, D., Jennings, S., 2005. Power of monitoring programs to detect decline and recovery of rare and vulnerable fish. *J. Appl. Ecol.* 42, 25-37.
- McClanahan, T.R., Mangi, S.C., 2004. Gear based management of a tropical artisanal fishery based on species selectivity and capture size. *Fish. Manag. Ecol.* 11, 51-60.
- Moussalli, E., Haile, T., 2001. Ex post Evaluation of the Semhar Fisheries Rehabilitation Project ERI/92/001(UNDP) ERI/92/C01 (UNCDF) and Capacity Building for the National Marine Resources Programme ERI/94/001 (UNDP). UNDP, 53 pp.
- Munro, J. L., 1996. The scope of tropical reef fisheries and their management. In: Polunin, N.V.C., Roberts, C.M. (eds), *Reef fisheries*. Chapman and Hall. London, pp 1-14.
- Munro, J.L., Smith, I.R., 1984. Management strategies for multispecies complexes in artisanal fisheries. *Proc. Gulf carb. Fish. Inst.* 36, 127-141.
- McClanahan, T. R., Graham, N. A. J., Calnan J. M., Macneil, M. A., 2007. Toward pristine biomass: Reef fish recovery in coral reef marine protected areas in Kenya. *Ecol. Appl.* 17, 1055-1067.
- Ministry of Fisheries, 2002. Executive Summary of the Ministry of Fisheries Report. Massawa, Eritrea.
- Morgan, G., 2006. Country review: Eritrea. In: De Young, C. (Ed.), *Review of the state of world marine capture fisheries management: Indian Ocean*. FAO Fisheries Technical Paper. No. 488, FAO, Rome, 458 pp.
- Myers, R.A. and Worm, B., 2003. Rapid worldwide depletion of predatory fish communities. *Nature* 423: 280-283.
- Nguyen Khoa, S., Lorenzen, K., Garaway, C., Chamsinhg, B., Siebert, D.J., and Randone, M. 2005. Impacts of irrigation on fisheries in rain-fed rice-farming landscapes. *J. Appl. Ecol.* 42: 892-900.
- Pauly, D., Christensen, V., Guenette, S., Pitcher, T.J., Sumaila, U.R., Walters, C.J., Watson, R., Zeller, D., 2002. Towards sustainability in world fisheries. *Nature*, 418, 689-695.
- Pauly, D., 1994. *On the Sex of Fish and the Gender of Scientists: Collected Essays in Fisheries Science*. Chapman and Hall, London.

- Pauly, D., 1997. Small-scale fisheries in the tropics: marginality, marginalization and some implications for fisheries management. In: E.K. Pikitch, D.D. Huppert, Sissenwine, M.P. (Eds.), *Global Trends: Fisheries Management*. American Fisheries Society Symposium 20, Bethesda, pp 40-49.
- Pauly, D., Christensen, V., Dalsgaard, J., Froese, R., Torres, F.C., 1998. Fishing down marine food webs. *Science* 279, 860-863.
- Pauly, D., Christensen, V., Walters, C., 2000. Ecopath, Ecosim and Ecospace as tools for evaluating ecosystem impact of fisheries. *ICES J. Marine Sci.* 57, 697-706.
- Pet Soede, C., Van Densen, W.L.T., Pet, J.S., Machiels, M.A.M., 2001. Impact of Indonesian coral reef fisheries on fish community structure and the resultant catch composition. *Fish. Res.* 5, 35-51.
- Polacheck, T., 2006. Tuna longline catch rates in the Indian Ocean: did industrial fishing result in a 90% rapid decline in the abundance of large predatory species? *Marine Policy*, 30, 470-482.
- Polunin, N.V.C, Roberts, C. M., 1993. Greater biomass and value of target coral-reef fishes in two small Caribbean marine reserves. *Mar. Ecol. Progr. Ser.* 100, 167-176.
- Reynolds, J.E., Appellton, J., Bellemans, M.S., Bonzon, A., Christy, L.C., 1993. The fisheries of Eritrea, Part 1:Sector review. part 2: Proposed national fisheries strategy and development program. Terminal Report, FI:FAO/TCP/ERT/2251.FAO, Rome.
- Rochet, M.J., Trenkel, V.M., 2003. Which community indicators can measure the impact of fishing? A review and proposals. *Can. J. Fish. Aquat. Sci.* 60, 86-99.
- Russ, G.R., 1991. Coral reef fishes: effects and yields. In: Sale, P.F. (Ed.), *The Ecology of Fishes on Coral Reefs*. Academic Press, San Diego, pp. 601-635.
- Sadovy, Y.J., 2005. Trouble on the reef: the imperative for managing vulnerable and valuable fisheries. *Fish Fish.* 6, 167-185.
- Salas, S., Sumaila, U.R., Pitcher, T., 2004. Short-term decisions of small scale fishers selecting alternative target species: a choice model. *Can. J. Fish. Aquat. Sci.* 61, 374-383.
- Sparre, P., Venema, S.C., 1998. Introduction to tropical fish stock assessment, Part 1, manual. FAO Fish. Tech. Pap. No. 306.1, Rev. 2. FAO, Rome, 407 pp.
- Schaefer, M.B., 1954. Some aspects of the dynamics of populations important to the management of the commercial fisheries. *Inter-Amer. Trop. Tuna Comm. Bull.*, 1, 27-56.
- Scheffer, M., Carpenter, S. R., Foley J.A., Folke, C. and Walker, B., 2001. Catastrophic shifts in ecosystems. *Nature* 413, 591-596.
- Sibert, et al., 2006. Biomass, Size, and Trophic Status of Top Predators in the Pacific Ocean. *Science* 314: 1773.
- Teh, L., Cabanban, A., Sumaila., U. R., 2005. The reef fisheries of Pulau Banggi, Sabah: A preliminary profile and assessment of ecological and socio-economic sustainability. *Fish.*

- Res. 7, 359-367.
- Van Oostenbrugge, J.A.E., Bakker, E.J, van Densen, W.L.T., Machiels, M.A.M, van Zwieten, P.A.M., 2002. Characterizing catch variability in a multispecies fishery: implications for fishery management. *Can. J. Fish. Aquat. Sci.* 59, 1032-1043.
- Vasconcellos, M., Cochrane, K., 2005. Overview of world status of data-limited fisheries: Inferences from landing statistics. In: Kruse, G.H., Gallucci, V.F., Hay, D.E., Perry, R.I., Peterman, R.M., Shirley, T.C., Spencer, P.D., Wilson, B., Woodby, D. (Eds), *Fisheries Assessment in Data-Limited Situations. Proceedings of the 21st Lowell Wakefield fisheries symposium*. Fairbanks, Alaska, pp 1-20.
- Walters, C., 2003. Folly and fantasy in the analysis of spatial catch rate data. *Can. J. Fish. Aquat. Sci.* 60, 1433–1436.
- Watson, M., Ormond, R.F.G., 1994. Effect of an artisanal fishery on the fish and urchin populations of a Kenyan coral reef. *Mar Ecol. Progr. Ser.* 109, 115-129.
- Welcomme, R.L., 1999. Review of a model for qualitative evaluation of exploitation levels in multi-species fisheries. *Fish. Manag. Ecol.* 6, 1-20.

Summary (in English, Dutch and Tigrigna)

Summary

Elucidating trends in catch rate and composition is important to evaluate the impact of fishing on fish stocks and thereby guide fisheries management action. However, fishing impacts are often treated as synonymous with overfishing, with most studies focusing on simple comparisons of heavily and lightly fished or unfished areas, or on examination of drastic declines. However, since major changes in fish community structure can take place even at the initial stages in the development of fisheries, it is important to assess the impacts of fishing in newly developing fisheries. The onset of reef fisheries in the Eritrean Red Sea thus provides a good opportunity to assess the effects of fishing on fish community structure in the early stages of fisheries. The artisanal reef fisheries of Eritrea were launched into a renewed development in 1991 after the end of a decades-long standstill, which was caused by the war for Eritrea's independence. The reef fish stocks have since been mainly exploited by artisanal fisheries. The main objective of this thesis was to evaluate the sustainability of existing fishing practices in the newly developing artisanal reef fisheries of Eritrea, while simultaneously examining the possibilities for extracting useful information on the state of fisheries and fish stocks from landing data in these rather data-limited fisheries. Furthermore, this thesis investigates approaches to improving the effectiveness of existing monitoring programs in order to gain a better insight into the state of fish stocks and fisheries.

Analysis of official statistics from the artisanal fisheries showed that annual effort and annual catch increased upon the expansion of fisheries, while the total catch rate remained unchanged over the years (Chapter 2). However, disaggregation of catch rates into different taxonomic and ecological categories showed that whereas the catch rates of higher-value demersals, such as snappers (Lutjanidae), groupers (Serranidae) and emperors (Lethrinidae) decreased, those of reef-associated pelagics such as barracudas (Sphyraenidae), tunas (Scombridae) and jacks (Carangidae) increased. The varying trends in catch rates of the different groups of fishes resulted in a clear shift in catch composition over the years, underlining the need to evaluate the sustainability of existing fishing practices. These results are not unlikely given the supposedly large amounts of unreported catches, which are mostly taken illegally to Yemen. This is more so given the highly selective nature of species targeting strategies in the artisanal fisheries. These findings are also consistent with other studies suggesting that stocks of reef-associated demersal species are highly vulnerable to fishing and can decline even at the early stages of fisheries. Moreover, the

results from this study show that the impacts of fishing in the artisanal fisheries could even become more severe if market conditions improve leading to the activation of latent fishing capacity, which made up about 75% of the registered fleet.

In the use of catch and effort data to monitor the state of fish stocks, changes in catch rate are assumed to reflect changes in fish abundance, with changes in species composition implying changes in fish community structure. However, the composition of landings could also be affected by a number of phenomena that are simply not related to increased fishing pressure – e.g. changes in target species, changes in fishing technology, and natural oscillations in abundance – potentially leading to spurious conclusions regarding the state of fish stocks. In this study, even though the changes in catch rate could be interpreted as reflecting changes in the underlying fish community structure, they could also be partly due to shifts in fish targeting strategies driven by socio-economic circumstances (Chapter 3). In the examination of changes in catch rate in relation to socio-economic variables in a multivariate model, changes in socio-economic circumstances were found to account for a considerable proportion (19.4%) of the changes in catch composition over the years. These findings underline the need to address the socio-economic aspects of fisheries alongside the biological dynamics of fish stocks in the monitoring and management of fisheries.

The lack of sufficient biological data in most reef fisheries impedes direct interpretation of the ecological significance of trends in catch rate and composition derived from fishery-dependent statistics. Therefore, it is important to ensure an accurate and effective use of catch and effort data for the monitoring of fisheries and fish stocks. For the artisanal fisheries of Eritrea, the relationship between catch rate and effort (hence the impacts of fishing) could be elucidated more accurately by standardizing catch rates ($\text{kg}\cdot\text{trip}^{-1}$) for systematic variations among fishing vessels, which would otherwise cause non-random variations in catch rate unrelated to abundance (Chapter 2 and 3). For these fisheries, about 15% of the variations in catch rate over the years could be attributed to boat and gear effects. Besides minimizing bias, the removal of systematic differences in catch rate also resulted in a considerable reduction in variability, allowing trends in catch rate to become more apparent. These results stress the need to develop a catch and effort recording system that accounts for as many sources of bias as possible in order to improve the effectiveness of fisheries monitoring programs, particularly considering the lack of sufficient resources for the collection of fishery-independent statistics in most reef fisheries.

The effectiveness of monitoring programs can also be improved through aggregation of

catch data. Indeed, aggregate data provide much of the evidence for trends in catch rates in many fisheries, because trends in individual species are often blurred by high variability. Aggregation of catch data across all species may however obscure trends in the abundance of individual species, as total catch rate often tends to remain constant despite varying trends in the abundance of these species. This study demonstrates that the choice of an appropriate level of aggregation requires trade-offs between reducing variability to achieve a higher statistical power on one hand and attaining an accurate depiction of temporal patterns in catch rates on the other (Chapter 4). For the multispecies reef fisheries of Eritrea, catch data could be aggregated into three distinct ecological categories, without a considerable loss of information on trends in the catch rate of individual species. These categories included reef-associated demersals, open-water pelagics and near-reef pelagics. Aggregation of catch data into these ecological categories was found to improve the statistical power to detect trends. Moreover, besides improving statistical power, aggregate catch rates could provide better insight into community-level responses to exploitation.

Ecological modeling was also shown to be a useful tool for examining the ecological significance of trends derived from fishery-dependent statistics in the artisanal fisheries (Chapter 5). Given the scarcity of biological data in most reef fisheries, the use of models with limited data requirements, such as the mass-balance ecosystem model Ecopath with Ecosim, are suggested as being the most viable option for evaluating the status of fish stocks and exploring optimal fisheries management scenarios. In this study, an Ecopath with Ecosim model was used to verify if the fishery-induced changes in yield and abundance of fish implied by official statistics are likely, given the existing levels of fishing intensity. This model was also used to explore optimal harvesting strategies by examining the ecosystem effects of fishing in the artisanal fisheries. A retrospective simulation of trends for these fisheries using Ecosim showed that, given the existing fishing intensity as suggested by official statistics, a decline in yield or abundance of reef-associated demersals of the magnitude suggested by trends in catch rate are unlikely. The decline in yield observed in these fisheries could however be reproduced in an Ecosim simulation when the existing fishing level was assumed to be fivefold the official estimate, as suggested by the anecdotal evidence on unreported catches. The simulation results also suggest that an optimal fishing strategy could be achieved in the artisanal fisheries through a slight reduction in the annual catch of reef-associated fishes (to $0.32 \text{ tonnes}\cdot\text{km}^{-2}\cdot\text{year}^{-1}$), and a simultaneous increase in the capture of near-reef pelagics and large pelagics (to 0.19, and $0.39 \text{ tonnes}\cdot\text{km}^{-2}\cdot\text{year}^{-1}$, respectively) from the putative levels of fishing.

Finally, the management implication of the trends in catch rate and composition observed in the artisanal fisheries is that major changes in fish community can take place even at the initial stages in the development of fisheries, and thus they need to be critically monitored. The concentration of fishing effort on selected species and/or specific areas could also have potentially adverse consequences for the sustainability of the artisanal fisheries. Therefore, the continued strong economic incentive for the artisanal fishers to mainly target reef-associated demersal fishes remains a cause for concern in the management of the Eritrean fisheries. Moreover, the sizable latent fishing capacity in the artisanal fisheries would represent a considerable potential for rapid expansion of fisheries in case of improving market circumstances. In conclusion, even though there is no evidence of drastic declines of fish stocks in the artisanal fisheries as yet, it is important that fishing activities are well dispersed over the whole range of coastal and island reef, and open water systems, and target a more diverse array of species before the fisheries undergo irreversible changes.

Samenvatting

Het verhelderen van trends in vangstsucces en vangstsamenstelling is van belang om de effecten van visserij op visbestanden te evalueren en om visserijbeheersmaatregelen te sturen. De effecten van visserij worden echter vaak beschouwd als synoniem aan overbevissing. De meeste studies zijn dan ook gericht op eenvoudige vergelijkingen van zwaar en licht beviste gebieden, of op het onderzoeken van drastische afnames. Het is echter ook mogelijk dat veranderingen in de structuur van de visgemeenschap al plaatsvinden tijdens de beginfase van een zich ontwikkelende visserij. Het is dan ook belangrijk om visserijeffecten al vanaf het begin van de ontwikkeling van een visserij te volgen. Die gelegenheid werd geboden door de artisanale rifvisserij in het Eritrese deel van de Rode Zee. Deze visserij werd weer opgestart in 1991 aan het einde van een decennialange stilstand die werd veroorzaakt door de onafhankelijkheidsoorlog. Sindsdien zijn de bestanden van rifvissen voornamelijk door artisanale vissers geëxploiteerd. Het doel van dit proefschrift was tweeledig. Enerzijds was het de bedoeling om de duurzaamheid van de bestaande visserijpraktijk in de zich opnieuw ontwikkelende artisanale rifvisserij van Eritrea te evalueren. Anderzijds was het doel om de mogelijkheden te onderzoeken om bruikbare informatie over de toestand van de visbestanden en de visserij af te leiden uit deze nogal gegevensarme visserij. Verder wordt in dit proefschrift een aanpak onderzocht om de effectiviteit van het bestaande monitoringprogramma te verbeteren om zo een beter inzicht in de toestand van de visbestanden en de visserij te verkrijgen.

Analyse van de officiële visserijstatistieken van de artisanale visserij toonde dat de jaarlijkse visserijinspanning en vangsten met de jaren toenamen, terwijl het totale vangstsucces niet veranderde (hoofdstuk 2). Als echter naar het vangstsucces voor afzonderlijke taxonomische en ecologische groepen werd gekeken dan bleek dat het vangstsucces voor kostbare, demersale soorten zoals snappers (Lutjanidae), tandbaarzen (Serranidae) en straatvegers (Lethrinidae) afnam, terwijl het vangstsucces voor rifgeassocieerde pelagische soorten zoals barracuda's (Sphyraenidae), tonijnen (Scombridae) en horsmakrelen (Carangidae) toenam. Over de jaren heen resulteerden deze verschillende trends in een duidelijke verschuiving in de vangstsamenstelling. Dit duidt erop dat er behoefte is aan een evaluatie van de duurzaamheid van deze visserij. De verschuivingen die werden gevonden zijn niet onwaarschijnlijk, gegeven de kennelijk grote hoeveelheden vis die niet worden geregistreerd en meestal illegaal naar Jemen worden uitgevoerd. De waargenomen veranderingen zijn ook consistent met de resultaten van andere studies die

suggereren dat bestanden van rif-geassocieerde demersale soorten zeer gevoelig zijn voor visserij en zelfs al sterk kunnen afnemen in de eerste fasen van zich ontwikkelende visserijen. De effecten van de artisanale visserij zouden zelfs nog ernstiger kunnen worden als de marktomstandigheden zouden verbeteren. Verbeterde marktomstandigheden zouden er namelijk toe kunnen leiden dat het latente deel van de vissersvloot (ongeveer 75% van de geregistreerde vissersboten) weer actief zou worden.

Als gegevens over vangst en visserijinspanning worden gebruikt om de toestand van visbestanden te volgen, dan wordt aangenomen dat veranderingen in vangstsucces een afspiegeling zijn van veranderingen in de talrijkheid van de vissen. Veranderingen in vangstsamenstelling betekenen dan ook veranderingen in de samenstelling van de visgemeenschap. De vangstsamenstelling kan echter ook worden beïnvloed door oorzaken die niets met toegenomen visserijdruk te maken hebben, maar meer met veranderingen in de visstrategie (bijvoorbeeld veranderingen in de doelsoorten van de visserij of in visserijtechnologie), of natuurlijke variaties in talrijkheid. Dergelijke factoren kunnen leiden tot valse conclusies met betrekking tot de toestand van de visbestanden. Ondanks dat in deze studie de veranderingen in vangstsucces konden worden geïnterpreteerd als veranderingen in de onderliggende samenstelling van de visgemeenschap, konden ze ook deels worden toegeschreven aan verschuivingen in de visstrategie, gedreven door socio-economische omstandigheden (hoofdstuk 3). In het multivariate model van veranderingen in vangstsucces in relatie tot socio-economische variabelen, werd gevonden dat die laatste een aanzienlijk deel (19,4%) van de veranderingen in vangstsamenstelling over de jaren verklaarden. Deze resultaten onderstrepen dat het belangrijk is om zowel socio-economische aspecten van de visserij, als de biologische dynamiek van visbestanden te beschouwen in de monitoring en het beheer van de visserij.

Het gebrek aan voldoende biologische gegevens in de meeste rifvisserijen bemoeilijkt directe interpretatie van het ecologische belang van de trends in vangstsucces en vangstsamenstelling die uit de visserijafhankelijke statistieken zijn afgeleid. Toch kan behoedzaam gebruik van gegevens over vangsten en visserijinspanning bruikbare inzichten in de toestand van visbestanden en de visserij opleveren. Een manier om de relatie tussen vangstsucces en visserijinspanning (en dus het effect van de visserij) in de artisanale visserij van Eritrea te verduidelijken is door vangstsucces ($\text{kg} \cdot \text{trip}^{-1}$) te standaardiseren voor systematische verschillen tussen vissersboten. Verschillen tussen vissersboten zouden anders onwillekeurige variaties in vangstsucces veroorzaken die geen verband houden met de talrijkheid van de visbestanden (hoofdstukken 2 en 3). Voor de artisanale visserij kon

ongeveer 15% van de variatie in vangstsucces over de jaren worden toegeschreven aan variatie in boten en vistuigen. Het verwijderen van systematische verschillen zorgde ook voor een aanzienlijke reductie in de variabiliteit, waardoor trends in vangstsucces duidelijker aantoonbaar werden. Deze resultaten benadrukken het belang van een systeem voor de registratie van vangsten en visserijinspanning dat zoveel mogelijk bronnen van variatie voor vangsten registreert, vooral omdat in de meeste riviervisserijen meestal de middelen ontbreken om visserijonafhankelijke gegevens te verzamelen.

De effectiviteit van monitoringprogramma's kan ook worden verbeterd door aggregatie van vangstgegevens. Het is zelfs zo dat in veel visserijen geaggregeerde gegevens veel van het bewijs voor trends in vangstsucces leveren, omdat trends in afzonderlijke soorten vaak verborgen blijven door hoge variabiliteit rond de trends. Aggregatie van vangstsucces over alle soorten kan echter trends in de talrijkheid van afzonderlijke soorten maskeren, omdat totaal vangstsucces vaak de neiging heeft constant te blijven, ondanks de verschillende trends in de talrijkheid van de samenstellende soorten. Deze studie toont dat de keuze van het juiste aggregatieniveau een afweging vergt tussen enerzijds de reductie van variabiliteit om een hogere statistische gevoeligheid voor het aantonen van trends te verkrijgen en anderzijds het verkrijgen van een nauwkeurige weergave van tijdsontwikkelingen in vangstsucces (hoofdstuk 4). Voor de multispecies visserij van Eritrea konden de vangstgegevens worden geaggregeerd in drie ecologische categorieën zonder veel verlies van informatie over trends in het vangstsucces van individuele soorten. Deze categorieën zijn rif-geassocieerde, demersale soorten, openwater pelagische soorten en rif-geassocieerde pelagische soorten. Aggregatie van vangstgegevens in deze duidelijk te onderscheiden ecologische categorieën verbeterde de statistische gevoeligheid voor het detecteren van trends. Bovendien kunnen geaggregeerde vangstsuccesen mogelijk een beter inzicht geven in de respons op exploitatie op het niveau van de visgemeenschap als geheel.

Ecologische modellering bleek ook een bruikbaar instrument om het ecologische belang van de uit de visserijstatistieken afgeleide trends in de artisanale visserij te onderzoeken (hoofdstuk 5). Aangezien biologische gegevens in de meeste riviervisserijen schaars zijn, wordt het gebruik van modellen met beperkte gegevensvereisten gesuggereerd als de beste optie om de toestand van de visbestanden te evalueren en optimale visserijbeheersscenario's te verkennen. Het massabalansmodel Ecopath met Ecosim werd in deze studie gebruikt om optimale oogststrategieën te verkennen door de ecosysteemeffecten van de artisanale visserij te onderzoeken. Een retrospectieve simulatie van trends in deze visserij met Ecosim toonde aan dat het onwaarschijnlijk is dat afnames in vangsten en talrijkheid van rif-

geassocieerde demersale vissoorten, zoals afgeleid uit trends in vangstsucces, veroorzaakt zijn door de visserijintensiteit zoals die in de officiële vangststatistieken is vermeld. De waargenomen afname in vangsten kon alleen worden gereproduceerd in de Ecosim simulatie als werd aangenomen dat de werkelijke visserijintensiteit vijf maal hoger was dan de officiële schatting, wat gesuggereerd wordt door anekdotisch bewijs voor illegale vangsten. Simulatieresultaten suggereren ook dat een optimale strategie voor de artisanale visserij kan worden bereikt door een lichte reductie in de jaarlijkse vangst van rif-geassocieerde demersale vissen (tot $0.32 \text{ tonnes} \cdot \text{km}^{-2} \cdot \text{jaar}^{-1}$) en een toename in de vangst van rif-geassocieerde pelagische en openwater pelagische soorten (tot respectievelijk 0.19 en $0.39 \text{ tonnes} \cdot \text{km}^{-2} \cdot \text{jaar}^{-1}$).

De beheersimplicaties van de waargenomen trends in vangstsucces en –samenstelling in de artisanale visserij is dat veranderingen in de visgemeenschap al kunnen plaatsvinden in de initiële fasen van de ontwikkeling van een visserij en dat de ontwikkelingen in de visserij daarom vanaf het begin kritisch moet worden gevolgd. De concentratie van visserijinspanning op specifieke soorten en/of gebieden kan eveneens potentieel negatieve consequenties hebben voor de duurzaamheid van de artisanale visserij. Daarom is het een zorgelijk voor het beheer van de Eritrese visserij dat er een voortdurend sterke economische drijfveer voor de visserij is om zich te concentreren op rif-geassocieerde, demersale vissoorten. Bovendien vormt de grote, latente visserijcapaciteit een potentieel voor een snelle uitbreiding van de visserij als de marktomstandigheden zouden verbeteren. Concluderend kan worden gesteld dat zelfs nu er nog geen bewijs is voor drastisch afnames van de visbestanden in de artisanale visserij, het toch belangrijk is dat de visserijactiviteit wordt gespreid over het hele rif langs de kust en eilanden en over de openwater systemen en dat de visserij zich op een diverse reeks vissoorten richt, voordat irreversibele veranderingen optreden.

ምርጫ ምክርቤት ፍርያት ሃብቲ ዓሳ
ምግፋፍ ዓሳታት ኮራል ሪፍ ኣብ ቀይሕ ባሕሪ ኤርትራ

ብምግፋፍ ዓሳ ኣብ ኮራል ሪፍስ ኣብ ብዘሕን ዓይነታትን ዓሳ ዝመጽእ ለውጥታት ብቐጻሊ ምክትታል፡ ኣብ ምሕደራ ሃብቲ ዓሳ ዓቢ ኣገዳስነት ኣለዎ - ብፍላይ ከኣ ኣብ ብዙሕ መጽናዕቲ ዘይተገብርሎም ከባቢታት ከም በዓል ቀይሕ ባሕሪ ናይ ኤርትራ። ብሓፈሻ፡ ንሳዕቢናት ምግፋፍ ዓሳ ኣብ ዕቕር ሃብቲ ዓሳ (ፍሽ ስቶክስ) ዝምልከቱ መጽናዕትታት፡ መብዛሕትኦ ግዜ ኣብ፡ ብጽዑቕ ምግፋፍ ዓሳ ርእይ ማህሰይቲ ዝወረዶም ከባቢታትን ኩነታትን ዘተኮሩ ኢዮም። እንተኾነ ግን፡ ትሑት ደረጃ ምግፋፍ ዓሳ ከይተረፈውን ብዙሕ ለውጥታት ከሰዕብ ስለ ዝኸኣል፡ ኣብ ምምዕባል ዝርከቡ ኢንዱስትሪታት ምግፋፍ ዓሳ - ከም በዓል ናይ ኤርትራ - ኣብ ዕቕር ሃብቲ ዓሳ ዘምጽእዎ ለውጥታት ምክትታል ኣገዳሲ ኢዩ። ኣብ ኤርትራ ዝርከብ ኢንዱስትሪ ምግፋፍ ዓሳ፡ ብምክንያት ኩናት ንዓሰርተታት ዓመታት ኣቋሪጹ ድሕሪ ምጽናሕ፡ ኣብ 1991 ኢዩ ከምብሓድኻ ክዕቢ ጀሚሩ። ስለዚ፡ እዚ ከምብሓድኻ ዝዓቢ ዘሎ ኢንዱስትሪ ምግፋፍ ዓሳ ፡ ምግፋፍ ዓሳ ኣብ ዕቕር ሃብቲ ዓሳ ናይ ኮራል ሪፍስ፡ ኣብ ናይ መጀመርያ ዓመታት ዘምጽእ ለውጥታት ንምጽናዕ ጽቡቕ ዕድል ይፈጥር። እዚ መጽሓፍኪ እምበኣር፡ ውጽኢት ናይ፡ ኣብ ናይ ኤርትራ ኢንዱስትሪ ምግፋፍ ዓሳ ዘተኮሪ መጽናዕቲ፡ ኢዩ። ዓላማ ናይዚ መጽናዕቲ፡ ምግፋፍ ዓሳ ኣብ ቀይሕ ባሕሪ ኣብ ብዘሕን ዓይነታትን ዓሳታት ኮራል ሪፍ ዘምጽእ ለውጥታት ንምድህሳስን፡ ኣብ ርእሲኡውን፡ ካብ ዚራገፍ ዓሳ ዝእከብ ስታትስቲክስ ክሳብ ክንደይ፡ ንምክትታል ኩነታት ዕቕር ሃብቲ ዓሳ፡ ጠቓሚ ምዃኑ ንምግምጋምን ኢዩ። ካብዚ ሓለፉውን፡ ዓላማ ናይዚ መጽናዕቲ፡ ስታትስቲክስ ናይ ዝግፈፍ ዓሳ ብዘሓሸ ዝእከበሉ መንገድታት ምንዳይ ኢዩ።

ኣብ ኤርትራ፡ ስታትስቲክስ ፍርያት ዓሳ ከምዘነጸገ፡ ኣብ ዝሓለፈ ዓመታት (1996-2004) ክግፈፍ ዝጸንሐ ዓሳ፡ ካብ ዓመት ናብ ዓመት እንዳወሰኸ ኢዩ ክመጽእ ጸኒሑ። ኣብ ብዝሒ ዓሳ ዝኾነ ይኹን ናይ ምንካይ ምልክት እውን ኣይተራእየን። እንተኾነ ግን፡ ውጽኢት ናይዚ መጽናዕቲ፡ ከምዘሕብሮ (ምዕራፍ ክልተ)፡ ዓይነታት ዝተሓዘ ዓሳ ካብ ዓመት ናብ ዓመት እንዳተቐየረ ክመጽእ ጸኒሑ። እዚ ድማ፡ ኣብ ቀዳሞት ዓመታት ብብዝሒ ዝተሓዘ ዝነበሩ ዓሳታት፡ ከም በዓል ቦሃር፡ ኩሽር ክኾኑ እንከለዉ፡ ኣብዚ ናይ መወዳእታ ዓመታት ግን፡ ከም በዓል ዴራክ፡ ቱና፡ ዓጋምውን ብብዝሒ ይተሓዙ ኣለዉ። ብሓደ ወገን፡ እዚ ለውጥታት ዘምስ ኣብ ካልእ ከባቢታት ብምክንያት ጽዑቕ ምግፋፍ ዓሳ ዝመጽእ ለውጥታት ይመሰገል ኢዩ። ብዘይክኡውን፡ ተኣፋፍነት ናይ ኮራል ሪፍስ ዓሳታት ኣብ ግምት ብምእታው፡ ከምዚ ዓይነት ለውጥታት ክንጽብ ንክእል ኢና። ቦቲ ሓደ ወገን ግን፡ ከምዚ ዓይነት ለውጥታት - ነዚ ክሳብ ሕጂ ኣብ ትሑት ደረጃ ዘሎ ኢንዱስትሪ ምግፋፍ ዓሳ ኣብ ግምት ብምእታው - ካብ ትጽቢትና ወጻኢ ክኸውን ይኸእል ኢዩ። ክሳብ ሕጂ ዝተኣከበ ስታትስቲክስ ፍርያት ዓሳውን፡ ምግፋፍ ዓሳ ኣብ ትሑት ደረጃ ምህላዉ ኢዩ ዘርኢ። እንተኾነ ግን፡ ኣብ ርእሲቲ ብሕጋዊ መንገዲ ዝግፈፍ ዓሳ፡ ብዘይ ሕጋዊ መንገዲውን ዓሳ ናብ ሳሪባብቲ ሃገራት ከም ዚኸይድ ሓደ ሓደ ሓበሬታታት ኣሎ። ነዚ ሓበሬታታት ዘኣብ ግምት ብምእታው ከኣ፡ እዚ ኣብ ላዕሊ ዝተጠቐሰ

ለውጥታት ምናልባት ካብ ትጽቢትና ወጻኢ ክኸውን ኣይክእልን። ኣብ ርእሰዚውን፡ ምግፋፍ ዓሳ ኣብ ኤርትራ፡ ኣብ ውሱናት ዓይነታት ዓሳ ጥራይ ዘተኮረ ምዃኑ፡ ነዚ ዝተራእየ ለውጥታት ምክኑይ ክገብር ይኸእል ኢዩ። እዚ ከምዚሉ እንክሎ፡ ሕጂ ንግዚኡ ካብ ምግፋፍ ዓሳ ጠጠው ኢለን ዘለዎ ጀላቡ፡ ስርሐን ምስ ጀመራ፡ ኣብ መጻኢ፡ ምግፋፍ ዓሳ ኣብ ዕቕር ሃብቲ ዓሳ ዘምጽኦ ለውጢ፡ ካብዚ፡ ክሳብ ሕጂ ዝተራእየ ንላዕሊ ክኸይድ ከምዝኸእል፡ ውጽኢት ናይዚ መጽናዕቲዚ ይሕብር።

ኣብ ስታትስቲክስ ፍርያት ዓሳ ተሞርኪስካ ዝግበር ገምጋም ኩነታት ዕቕር ሃብቲ ዓሳ፡ ኣብ ብዝሕን ዓይነታትን ዝራገፍ ዓሳታት ዝርኦ ለውጥታት፡ ንኣብ ውሽጢ ባሕሪ ዝህሉ ለውጥታት ዘንጸባርቕ ኢዩ። ኣብ ዝብል ግምት ብምምርኳስ ኢዩ። እንተኾነ ግን፡ ኣብ ዝራገፍ ዓሳታት ዝርኦ ለውጥታት፡ ጠንቁ ካልእውን ክኸውን ይኸእል ኢዩ - ንኣብነት ምቅይያር መሳርሒታት መግፈፊ ዓሳ፡ ምቅይያር ምርጫ ገፈፍቲ ዓሳ ወዘተ። ስለዚ፡ ዋሳኔ ኣብ ብዝሕን ዓይነትን ዝተሓዘ ዓሳ ዝተራእየ ለውጢ፡ ንኣብ ውሽጢ ባሕሪ ዝህሉ ለውጥታት ዘንጸባርቕ ኢዩ ኢልና እንተገመትና፡ ምቅይያር ማሕበረ-ቁጠባዊ ኩነታት ገፈፍቲ ዓሳውን፡ ኣብ ብዝሕን ዓይነትን ዝተሓዘ ዓሳ ሳዕቡን ክህልዎ ይኸእል ኢዩ። ውጽኢት ናይዚ መጽናዕቲዚ ከምዝሕብር (ምዕራፍ ሰለስተ)፡ ካብቲ ኣብ ዝሓለፈ ዓመታት፡ ኣብ ዓይነታት ዓሳ ዝተራእየ ለውጢታት፡ ኣስታት 19.4% ዝኸውን ምስ ምቅይያር ማሕበረ-ቁጠባዊ ኩነታት ምግፋፍ ዓሳ ዝተሓሰር ኢዩ። ኣብዚ መጽናዕቲዚ ኣብ ግምት ካብ ዝኣተዉ ማሕበረ-ቁጠባዊ ረጃሒታት፡ ተዛማዲ ዋጋታት ዝተፈለለዩ ዓይነታት ዓሳ፡ ዋጋታት ነዳዲ (ብንዚንን ናፍታን)፡ ምጅማር ምግፋፍ ሲ-ኩካምበር፡ ዓይነት ጀላቡን፡ መግፈፊ ዓሳን ይርከብዎም። ብሓፊሻ፡ እዚ ኣብዚ መጽናዕቲዚ ዝተረኸበ ውጽኢት፡ ኩነታት ዕቕር ሃብቲ ዓሳ ኣብ እንግምግመሉ እዋን - ኣብ ርእሰቲ ባዮሎጂካዊ ዳህሳስ - ምቅይያር ማሕበረ-ቁጠባዊ ኩነታት ናይ ኢንዱስትሪ ምግፋፍ ዓሳውን ኣብ ግምት ምእታው ክሳብ ክንደይ ኣገዳሲ ምዃኑ የርኢ።

ዋሳኔ ባዮሎጂካዊ ሓበሬታ ኣብ ዝህልወሉ ኩነታት፡ ኣብ ስታትስቲክስ ፍርያት ዓሳ ዝርኦ ለውጥታት ክሳብ ክንደይ ንኣብ ዕቕር ሃብቲ ዓሳ ዝህሉ ለውጥታት ከም ዘንጸባርቑ ብቐጥታ ምግምጋም ኣጸጋሚ ይኸውን። ስለዚ፡ ኣብ ከምዚ ዝኣመሰለ ኩነታት፡ ስታትስቲክስ ፍርያት ዓሳ፡ ብጥንቃቄ ክንጥቀሙ ክንክእል ኣለና። በዚ መንጽርዚ፡ ኣብ ኢንዱስትሪ ምግፋፍ ዓሳ ናይ ኤርትራ፡ ኣብ ብዝሕን ዓይነታትን ዓሳታት፡ ለውጥታት (ቫርየሽንስ) ከምጽኡ ይኸእሉዮም ዝበሃሉ ረጃሒታት ተለልዮም፡ ናቶም ሳዕቡን ክሳብ ክንደይ ክኸውን ከምዝኸእል ተገምጊሙ። ኣብዚ መጽናዕቲዚ ዝተገበረ ስታትስቲካዊ ትንታኑ (ኦናልሲስ) ድማ፡ ኣብ ብዝሕን ዓይነታትን ዝተሓዘ ዓሳ ካብ ዝርኦ ለውጢ፡ ኣስታት 15% ዝኸውን፡ ብሰንኪ ኣብ ጀላቡን መሳርሒታት መግፈፊ ዓሳን ዘሎ ፍልልያት ከምዝመጽ፡ ይሕብር። ስለዚ፡ እቲ፡ ንኣብ ውሽጢ ባሕሪ ዝህሉ ኩነታት ዘየንጸባርቑ ለውጥታት (ቫርየሽንስ) ብምእላይ፡ ኣብ ዝተሓዘ ዓሳ (ካቶ) ዝርኦ ለውጥታት ክሳብ ክንደይ ንኣብ ውሽጢ ባሕሪ ዝህሉ ለውጥታት ከም ዘንጸባርቑ ምግምጋም ይከኣል። ካብቶም ኣብዚ መጽናዕቲዚ ኣብ ግምት ዝኣተዉ ረጃሒታት ወጻኢ፡ ካልኦት ኣብ ብዝሕን ዓይነትን ዓሳታት ለውጥታት ከስዕቡ ዝኸእሉ፡ ግን ከኣ

ኮራል ሪፍ ርዕይ ለውጥታት ከሰዕብ ከምዝኸኸልን፣ ቀጻሊ ምክትታል ምግባር አገዳሲ ምኅኒን። ካልአይ ድማ፣ ምግፋፍ ዓሳ አብ ኤርትራ፣ አብ ውሱናት ዓይነታት ዓሳታት ጥራይ ዘተኮረ ምኅኒን፣ ከምኡውን፣ ዓሳታት ኮራል ሪፍ፣ ብምግፋፍ ዓሳ ንዝመጽእ ሳዕቤናት አዝዮም ተኣፊፍቲ ብምኅኒንም፣ ምሕደራ ኢንዱስትሪ ምግፋፍ ዓሳ ናይ ኤርትራ ልዑል ጥንቃቄ የድልዮ። በዚ መንጽርዚ፣ እቲ ንገፊፍቲ ዓሳ፣ አብ ውሱናት ዓይነታት ዓሳታት ጥራይ ከተኩሩ ዚድርኹ ማሕበራዊ-ቁጠባዊ ኩነታት - ንአብነት ተዛማዲ ጥጋታት ዝተፈላለዩ ዓይነታት ዓሳ፣ ጥጋታት መሳርሒታት መግፈፊ ዓሳ፣ ወዘተ - ፍሉይ ኣቓልቦ ክግበረሎም ይግባእ። ብተወሳኺ፣ ኩነታት ዕዳጋ እንዳ ተመሓየሽ አብ ዚኸደሉ እዋን፣ እተን ሕጂ ንግዚኡ ካብ ምግፋፍ ዓሳ ጠጠው ኢለን ዘለዋ ጀላቦ፣ ምሉእ ብምሉእ ስርሐን ምስ ጀመራ፣ አብ መጻኢ፣ ምግፋፍ ዓሳ አብ ዕቕር ሃብቲ ዓሳ ዘምጽኦ ለውጢ፣ ካብዚ ክሳብ ሕጂ ዝተራእየ ንላዕሊ ክኸይድ ስለዝኸኸል፣ አብ ምውፋር ዓቕሚ ጀላቦ፣ ልዑል ጥንቃቄ ምግባር ከድሊ ኢዩ። ከም መዛዘሚ፣ ዋላኳ ክሳብ ሕጂ፣ አብ ብዝሕን ዓይነትን፣ ከምኡውን አብ ኣቃውማ ሃብቲ ዓሳ ዝጋነን ለውጢ እንተዘይተራእየ፣ መስርሕ ምግፋፍ ዓሳ አብ ቀይሕ ባሕሪ፣ አብ ኩሉ ደሴታትን፣ ገማግም ባሕርን ምዕሩይ ዝርግሐ ክህልዎ፣ ከምኡ ድማ፣ አብ ክንዲ አብ ውሱናት ዓይነታት ዓሳታት ጥራይ፣ አብ ኩሎም ቁጠባዊ ኣገዳስነት ዘለዎም ዓሳታት ከተኩር ይግባእ። ምክንያቱ፣ ከምዚ ዘይምግባር፣ ብፍላይ፣ አብ ዕቕር ሃብቲ ናይቶም ልዑል ቁጠባዊ ኣገዳስነት ዘለዎም ዓሳታት፣ ብኣፈሻ ድማ፣ አብ ኣቃውማ ሃብቲ ባሕሪ፣ ብቀሊሉ ክጽገን ዘይክእል ማህሰይቲ ከውርድ ስለዝኸኸል።

Acknowledgements

The completion of this thesis would not have been possible, had it not been for the assistance and cooperation I received from several individuals and institutions.

I am especially indebted to my promotor Prof. Johan Verreth, and my co-promotor Dr. Leo Nagelkerke, for their critical support and guidance. I am very grateful to Johan for his encouragement, and for his insightful reviews on my draft articles, which greatly improved the quality of this work. I am very thankful to Leo for his unrelenting support all the way from the inception of my study through the writing up of this thesis. I am also grateful for his visits to Eritrea during my fieldwork, which helped me tackle the various setbacks I encountered during data collection. I am enormously appreciative that he could see a possible way forward, even when the situation seemed untenable. Besides my supervisors, many others contributed a great deal toward the completion of the thesis. Ir. Paul van Zwieten played a great role in bringing a higher standard to some of my articles, for which I am very thankful. I owe a big debt to Prof. John Videler for his encouragement throughout my study, and for his critical review on the draft articles during the writing up of the thesis. Special thanks are due to Dr. Marcel Machiels for his assistance in the statistical analysis of my data, especially at the initial stages of the study. I am also thankful to Dr. Wim van Densen for his interest in my thesis – and in the reef fisheries of Eritrea, for that matter – and for his moral support.

I would also like to thank all my (ex-)colleagues and friends at the Aquaculture and Fisheries group for their warm collegiality. Special thanks go to Gonçalo, Miriam, Nhan, Mohammed, Catarina, Paula, Pascal, Sharif, An, Gigi, Rina, Roel, Mark, Johan S, Helene, Gera, Ep, Ronald B, Ronald O, Tino, Menno, Nghia, Karen, Yonas, Oliver, Titu, Patricia, Harrison, Jascha, Konrad, Stephan, Tim, Luca, Marco and others. I especially enjoyed the exotic dinners I shared with my PhD colleagues, and the birthday cakes served in the corridor of AFI.

The staff of the Department of Marine Sciences, in Eritrea deserve my gratitude, particularly Dr. Zekeria Abdulkerim and Ghirmay Sahle (*Jimmy the tulip*) for their assistance during my fieldwork in Eritrea. Working on data-deprived fisheries, I needed every input I could get from just about everyone of them. I am also grateful to the University of Asmara, and the Ministry of Fisheries, Eritrea: Through their good offices, I

Acknowledgements

was able to arrange field trips and thereby obtain the fisheries statistics for this study. Especially, I would like to thank the people at the Research and Statistics Division of the Ministry of Fisheries for providing me with catch and effort data, and for their helpful discussions. Every time I visited there, I found welcoming and cooperative people. I am especially indebted to Amanual Ghebremichael, Sammy Mahmoud, Kahasse Taddesse, Awet Yemane, Yosief G., Amanual Hagos, for providing useful information and for lending a helping hand in the collection of data for this thesis. Special thanks are due to Stanley Hartmann, a former employee of the Research and Statistics Division of the Ministry of Fisheries, for introducing me to the catch and effort data recording system (CEDRS) of the Eritrean fisheries. I also owe special thanks to several BSc and MSc students, in Wageningen and in Eritrea, who contributed directly to the thesis, particularly Frederic Airaud and Nick Michailidis.

I have learned the ecological modeling tools I used in the thesis from the Fisheries Center at the University of British Columbia, Canada. I am very thankful to Prof. Daniel Pauly for allowing me to spend a one-semester study period at the Fisheries Center. Dr. Villy Christensen and Prof. Carl Walters of the Fisheries Center also deserve my appreciation for their advice, and for reviewing some of my papers.

Life would have been more difficult without the light moments I shared with my friends in Wageningen and elsewhere in the Netherlands. I am very grateful to many of my friends for the *gezellig* moments to cherish: Yonas, Sammy G, Sammy P, Danny Delft, Danny Tilburg, Semere, Abraham, Mike, Biniam *Bolognese*, Deby *en anderen*, Solomie, Hayat, Elilta, Solyana Subuh, Adaim and all my friends at the Bornsesteeg.

My deepest gratitude goes to my family in Eritrea, especially to my father Tsehaye Weldemichael and my mother Azieb Ghebrelul for being a constant source of inspiration to me. I am eternally grateful to them. I am also grateful to other members of my family in the US, UK and Germany – particularly my auntie Abrehet Ghebrelul in the US and my sister Ruth Tsehaye here in Wageningen – for their incessant moral support.

Iyob Tsehaye
Wageningen, November 2007

Training and supervision plan

Name PhD student	Iyob Tsehaye	Graduate school	WIAS
Project title	Monitoring Fisheries in data-limited situations: A case study of the artisanal reef fisheries of Eritrea		
Group	Aquaculture and Fisheries		
			
EDUCATION AND TRAINING	Year	ECTS	
The Basic Package			
WIAS Introduction Course	2003	1.5	
Course on philosophy of science and/or ethics	2003	1.5	
Subtotal Basic Package		3.0	
Scientific Exposure			
<i>International conferences</i>			
International symposium: Quantitative Ecosystem Indicators for Fisheries Management	2004	1.0	
4th World Fisheries Congress, Vancouver, British Columbia	2004	1.0	
ICES Annual Science Conference, Maastricht	2006	1.0	
<i>Seminars and workshops</i>			
WIAS Science Day 2003	2003	0.3	
Fish 500: Issues in Fisheries Research: Seminars, UBC, Vancouver, Canada	2003	4.5	
University of Asmara Research Center: Seminar Series	2005	0.3	
WIAS Science Day 2006	2006	0.3	
<i>Presentations</i>			
Poster: International symposium: Quantitative Ecosystem Indicators for Fisheries Management	2004	1.0	
Oral: 4th World Fisheries Congress, Vancouver, British Columbia	2004	1.0	
Oral: University of Asmara Research Center: Seminar Series	2005	1.0	
Poster: ICES Annual Science Conference, Maastricht	2006	1.0	
Subtotal Scientific Exposure		12.4	
In-Depth Studies			
<i>Disciplinary and interdisciplinary courses</i>			
FISH 504: Quantitative Analysis of Fisheries (UBC) (Prof. Carl Walters)	2003	4.5	
FISH 505: Quantitative Analysis of Fisheries (UBC) (Prof. Carl Walters)	2003	4.5	
<i>Advanced statistics courses</i>			
Design of Animal Experiments (Dr. Michael Grossman)	2002	1.0	
<i>Discussion groups</i>			
Fisheries work meetings		1.0	
Subtotal In-Depth Studies		11.0	
Professional Skills Support Courses			
WIAS Course Techniques for Scientific Writing	2003	1.2	
FISH 501: Ecosystem Modeling (UBC) (Prof. Daniel Pauly; Dr. Villy Christensen)	2003	4.5	
Subtotal Professional Skills Support Courses		5.7	
Research Skills Training			
Preparing own PhD research proposal	2002	6.0	
4-month study period at the Fisheries Center, UBC, Canada	2003	2.0	
Subtotal Research Skills Training		8.0	
Didactic Skills Training (optional)			
<i>Lecturing</i>			
Wageningen International: International fisheries management training workshop	2007	1.0	
<i>Supervising MSc theses</i>			
MSc Thesis: Trends in the artisanal fisheries of Eritrea	2003	2.0	
MSc Thesis: Changes in fisheries in relation to biological and socio-economic factors	2006	2.0	
Subtotal Didactic Skills Training		5.0	
Education and Training Total (minimum 30)		45.1	

One ECTS credit point represents a study load of 28 hours.

Curriculum vitae

Iyob Tsehaye was born on April 13, 1974 in Asmara, Eritrea. He initially started his university education in the Faculty of Technology at Addis Ababa University, in Ethiopia. He continued his university education in marine biology and fisheries at the University of Asmara, in Eritrea, where he obtained a BSc degree in 1995. He was subsequently recruited by the Department of Marine Biology and Fisheries at the same University to work as a graduate teaching and research assistant. After one year of employment, he was awarded a scholarship to pursue an MSc education at Wageningen University, and he obtained an MSc degree in fisheries biology and management in 1998. As part of his MSc study, he worked on a thesis on the use of biomass size distribution of zooplankton and young fish as a tool to assess the status of the aquatic community in Haringvliet–Hollandsch Diep, the Netherlands. After finishing his MSc study, he returned to Eritrea, and was working at the Department of Marine Biology and Fisheries (later renamed Department of Marine Sciences) as a lecturer until he was admitted to Wageningen University as a PhD student. During his tenure at the University of Asmara, he was also taking part in various research projects at the department, some including short expeditions in the Southern Red Sea. Seeking to gain an ecosystem-level insight into the effects of fisheries on coral reefs, the author compiled almost every information he could obtain from these and other research projects on the Red Sea for this thesis. The author has also attended the Fisheries Center at the University of British Columbia, Vancouver, Canada for one semester in 2003/2004 on a study-abroad program as part of his PhD study.

The author can be reached via e-mail at: Iyob_tsehaye@yahoo.com

List of publications

Iyob Tsehaye, Marcel A.M. Machiels and Leo A.J. Nagelkerke, 2007. Rapid shifts in catch composition in the artisanal Red Sea reef fisheries of Eritrea. *Fisheries Research* 86, 58-68.

Iyob Tsehaye, Leo A.J. Nagelkerke. *Accepted*. Exploring optimal fishing scenarios for the multispecies artisanal fisheries of Eritrea using a trophic model. *Ecological Modelling*.

Iyob Tsehaye, Leo A.J. Nagelkerke and P.A.M Zwieten. *Submitted*. Improving the effectiveness of monitoring programs in multispecies fisheries through aggregation of catch data into ecological categories. *Journal of Applied Ecology*.

Iyob Tsehaye, Leo A.J. Nagelkerke and Nick Michailidis. *Submitted*. Changes in catch composition in relation to biological and socio-economic factors. *Canadian Journal of Fisheries and Aquatic Sciences*.

Iyob Tsehaye, Leo A.J. Nagelkerke. *In preparation*. Monte Carlo evaluation of the implications of sampling error for the statistical power of fisheries monitoring programs.

Abstracts and Papers in Conference Proceedings

Iyob Tsehaye and Leo A.J. Nagelkerke, 2006. The effect of individual species variability on the use of the total catch as an indicator of trends in a multispecies fisheries in the Red Sea. Poster. 2006 ICES Annual Science Conference, Maastricht, the Netherlands, 19–23 September 2006.

Leo A.J. Nagelkerke and Iyob Tsehaye, 2006. Sampling fisheries with high levels of accepted relative error might lead to over-estimation of the statistical power of trend detection. Oral presentation. 2006 ICES Annual Science Conference, Maastricht, the Netherlands, 19–23 September 2006.

List of publications

Iyob Tsehaye and Leo A.J. Nagelkerke, 2004. Re-allocation of sampling effort can optimize the monitoring of artisanal fisheries and fish community changes in the Eritrean Red Sea. Oral Presentation. Fourth World Fisheries Congress, Vancouver, Canada. 02-06 May 2004.

Iyob Tsehaye, Marcel A.M. Machiels and A.J. Nagelkerke. 2004. Shifts in catch composition in the artisanal reef fisheries of Eritrea. Poster. International symposium on Quantitative Ecosystem Indicators for Fisheries Management, Paris, France, 31 March – 04 April 2004.

Iyob Tsehaye, 1999. Trends in catch, effort and CPUE in the artisanal reef fisheries in Eritrea. Oral Presentation. ACP-EU-FishBase-Ecopath training Workshop, Nairobi, Kenya, 23 August - 3 September 1999.

Iyob Tsehaye, 2002. The Need for a protected area system in fisheries and biodiversity management: The case of Eritrea. Oral Presentation. EU-Workshop: Policy Options for the Sustainable Use of Coral Reefs and Associated Coastal Ecosystems, Mombassa, Kenya, 12-22 June 2000.

Pupular articles

RESOURCE, 24 November 2005: Student records damage to coral reefs.
http://www.resource-online.nl/wb_artikel.php?r=1&id=2325

Notes

The study for this thesis was supported by the Netherlands Organization for International Cooperation in Higher Education (Nuffic) as part of the MBF–UoA–MHO project and by the Aquaculture and Fisheries group, Wageningen University.

Cover: A fishing boat (hour) off the coast of Massawa, Eritrea.

Photo: Leo A.J. Nagelkerke, 2004.

Design: Henok Tsehaye.

This thesis was printed by PrintPartners Ipskamp, Enschede, The Netherlands.